



ISSU and SSO--DHCP High Availability Features

Last Updated: December 20, 2011

Cisco IOS Release 12.2(31)SB2 introduces the following series of Dynamic Host Configuration Protocol (DHCP) High Availability features that support the Broadband Access Server (BRAS):

- ISSU--DHCP Server
- SSO--DHCP Server
- ISSU--DHCP Relay on Unnumbered Interface
- SSO--DHCP Relay on Unnumbered Interface
- ISSU--DHCP Proxy Client
- SSO--DHCP Proxy Client
- ISSU--DHCP ODAP Client and Server
- SSO--DHCP ODAP Client and Server

These features are enabled by default when the redundancy mode of operation is set to Stateful Switchover (SSO).

- [Finding Feature Information, page 1](#)
- [Prerequisites for DHCP High Availability, page 2](#)
- [Restrictions for DHCP High Availability, page 2](#)
- [Information About DHCP High Availability, page 2](#)
- [How to Configure DHCP High Availability, page 6](#)
- [Configuration Examples for DHCP High Availability, page 6](#)
- [Additional References, page 6](#)
- [Feature Information for DHCP High Availability Features, page 8](#)
- [Glossary, page 9](#)

Finding Feature Information

Your software release may not support all the features documented in this module. For the latest feature information and caveats, see the release notes for your platform and software release. To find information about the features documented in this module, and to see a list of the releases in which each feature is supported, see the Feature Information Table at the end of this document.



Americas Headquarters:
Cisco Systems, Inc., 170 West Tasman Drive, San Jose, CA 95134-1706 USA

Use Cisco Feature Navigator to find information about platform support and Cisco software image support. To access Cisco Feature Navigator, go to www.cisco.com/go/cfn. An account on Cisco.com is not required.

Prerequisites for DHCP High Availability

- The Cisco IOS In-Service Software Upgrade (ISSU) process must be configured and working properly. See the “[Cisco IOS In-Service Software Upgrade Process](#)” feature module for more information.
- Stateful Switchover (SSO) must be configured and working properly. See the “[Stateful Switchover](#)” feature module for more information.
- Nonstop Forwarding (NSF) must be configured and working properly. See the “[Cisco Nonstop Forwarding](#)” feature module for more information.

Restrictions for DHCP High Availability

The DHCP high availability features do not support DHCP accounting or DHCP authorized Address Resolution Protocol (ARP).

Information About DHCP High Availability

- [ISSU, page 2](#)
- [SSO, page 2](#)
- [ISSU and SSO--DHCP Server, page 3](#)
- [ISSU and SSO--DHCP Relay on Unnumbered Interface, page 3](#)
- [ISSU and SSO--DHCP Proxy Client, page 4](#)
- [ISSU and SSO--DHCP ODAP Client and Server, page 5](#)

ISSU

The ISSU process allows Cisco IOS software to be updated or otherwise modified while packet forwarding continues. In most networks, planned software upgrades are a significant cause of downtime. ISSU allows Cisco IOS software to be modified while packet forwarding continues, which increases network availability and reduces downtime caused by planned software upgrades.

SSO

SSO refers to the implementation of Cisco IOS software that allows applications and features to maintain a defined state between an active and standby Route Processor (RP).

In specific Cisco networking devices that support dual RPs, SSO takes advantage of RP redundancy to increase network availability. The SSO feature takes advantage of RP redundancy by establishing one of the RPs as the active RP while the other RP is designated as the standby RP, and then synchronizing critical state information between them. Following an initial synchronization between the two processors, SSO dynamically maintains RP state information between them.

A switchover from the active to the standby processor occurs when the active RP fails, is removed from the networking device, or is manually taken down for maintenance.

ISSU and SSO--DHCP Server

The DHCP server that is ISSU and SSO aware is able to detect when a router is failing over to the standby RP and preserve the DHCP lease across a switchover event.

Each DHCP binding is synchronized and re-created from the active RP to the standby RP upon lease commit. The lease extension and release are also synchronized to the standby RP.

Figure 1 DHCP Server Maintaining States Between the Active and Standby Route Processor

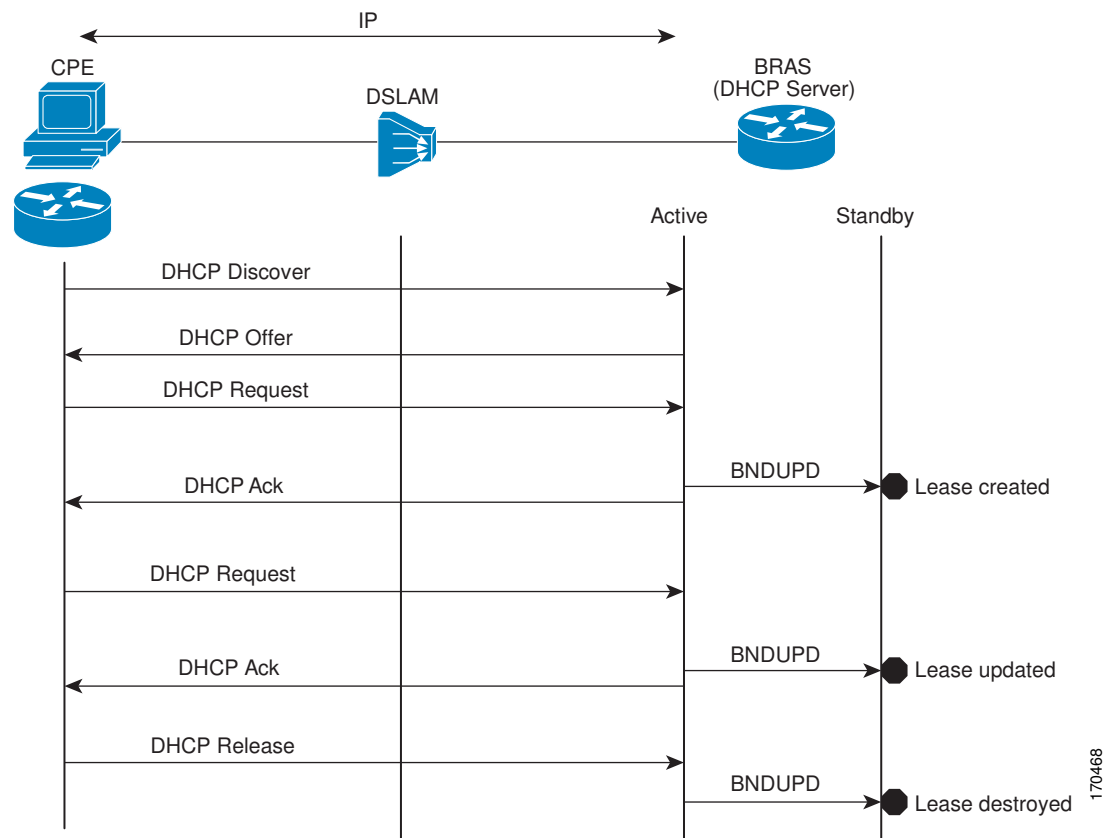

ISSU and SSO--DHCP Relay on Unnumbered Interface

The DHCP relay agent supports the use of unnumbered interfaces. For DHCP clients connected through the unnumbered interfaces, the DHCP relay agent automatically adds a static host route once the DHCP client obtains an address, specifying the unnumbered interface as the outbound interface. The route is automatically removed once the lease time expires or when the client releases the address.

The `ip helper-address` interface configuration command must be configured on the unnumbered interface to enable the Cisco IOS DHCP relay agent on unnumbered interfaces. See the [“Configuring the Cisco IOS DHCP Relay Agent”](#) configuration module for more information.

The ISSU and SSO DHCP relay on unnumbered interface functionality adds high availability support for host routes to clients connected through unnumbered interfaces. The DHCP relay agent can now detect

when a router is failing over to the standby RP and keep the states related to unnumbered interfaces. The figure below illustrates the process.

Figure 2 DHCP Maintaining States with an IP Unnumbered Interface

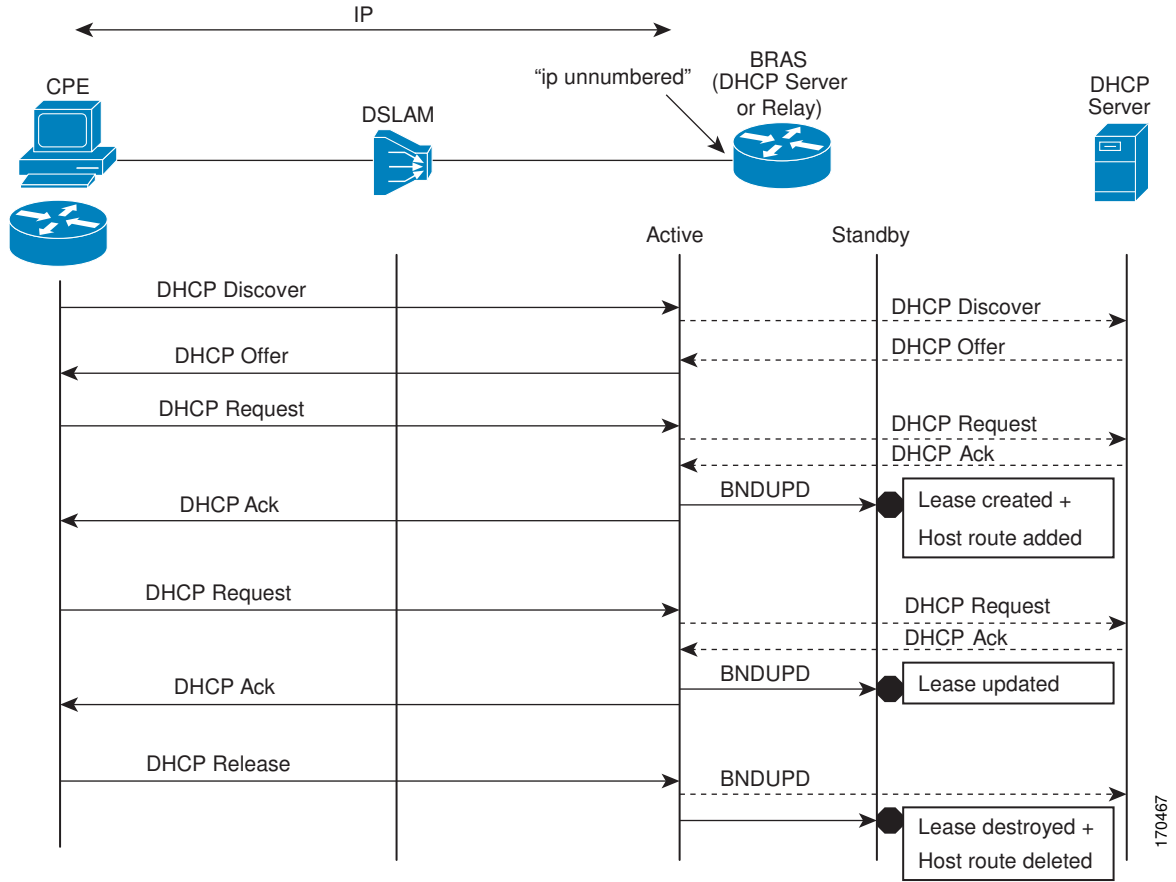

170467

ISSU and SSO--DHCP Proxy Client

The DHCP proxy client enables the router to obtain a lease for configuration parameters from a DHCP server for a remote Point-to-Point Protocol (PPP) client. The DHCP proxy client that is ISSU and SSO

aware is able to request a lease from the DHCP server and the state of the lease is synchronized between the active and standby RP. The figure below illustrates the process.

Figure 3 DHCP Proxy Client Lease Synchronization

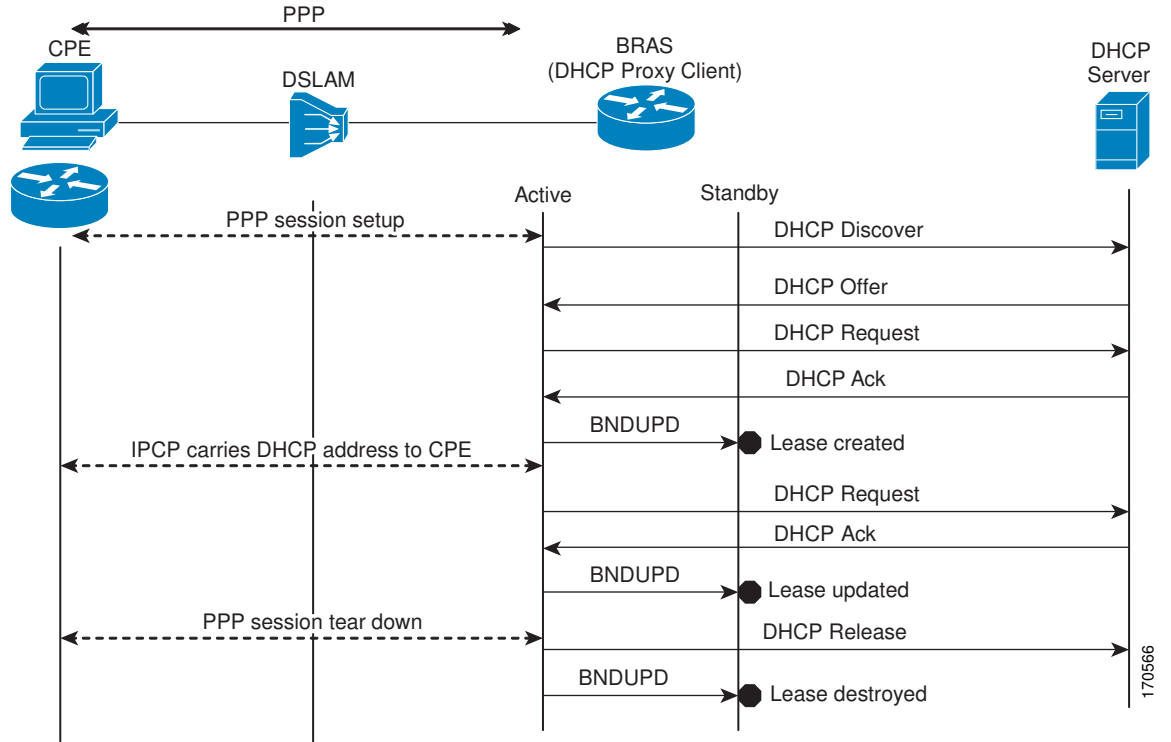

ISSU and SSO--DHCP ODAP Client and Server

The DHCP on-demand address pool (ODAP) client that is ISSU and SSO aware can request a lease for a subnet from the DHCP ODAP server. After the DHCP ODAP server allocates the subnet to the client, the state of the lease is synchronized between the active and standby RP through binding updates. Following a

switchover event, the DHCP ODAP client can continue to allocate IP addresses from the same subnets and also continue to renew the subnets from the DHCP ODAP server. The figure below illustrates the process.

Figure 4 ODAP Subnet Lease Synchronization

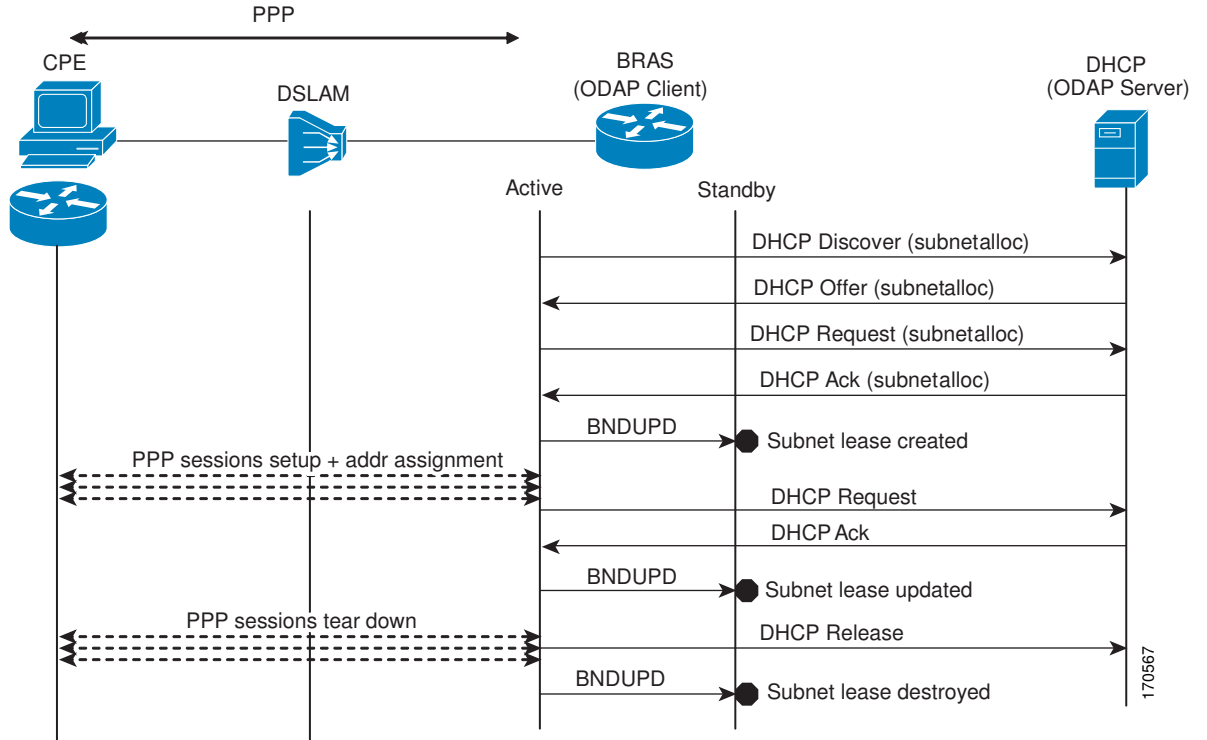

How to Configure DHCP High Availability

There are no configuration tasks. The DHCP high availability features are enabled by default when the redundancy mode of operation is set to SSO.

Configuration Examples for DHCP High Availability

There are no configuration examples for DHCP high availability features.

Additional References

Related Documents

Related Topic	Document Title
DHCP commands: complete command syntax, command modes, command history, defaults, usage guidelines, and examples	<i>Cisco IOS IP Addressing Services Command Reference</i>
DHCP conceptual and configuration information	<i>Cisco IOS IP Addressing Services Configuration Guide, Release 12.2SR</i>
In-Service Software Upgrade process conceptual and configuration information	"Cisco IOS In Service Software Upgrade Process" module
Nonstop Forwarding conceptual and configuration information	"Cisco Nonstop Forwarding" module
Stateful switchover conceptual and configuration information	"Stateful Switchover" module

Standards

Standard	Title
No new or modified standards are supported by this feature.	--

MIBs

MIB	MIBs Link
No new or modified MIBs are supported by this feature.	To locate and download MIBs for selected platforms, Cisco IOS releases, and feature sets, use Cisco MIB Locator found at the following URL: http://www.cisco.com/go/mibs

RFCs

RFC	Title
No new or modified RFCs are supported by this feature.	--

Technical Assistance

Description	Link
The Cisco Support and Documentation website provides online resources to download documentation, software, and tools. Use these resources to install and configure the software and to troubleshoot and resolve technical issues with Cisco products and technologies. Access to most tools on the Cisco Support and Documentation website requires a Cisco.com user ID and password.	http://www.cisco.com/cisco/web/support/index.html

Feature Information for DHCP High Availability Features

The following table provides release information about the feature or features described in this module. This table lists only the software release that introduced support for a given feature in a given software release train. Unless noted otherwise, subsequent releases of that software release train also support that feature.

Use Cisco Feature Navigator to find information about platform support and Cisco software image support. To access Cisco Feature Navigator, go to www.cisco.com/go/cfn. An account on Cisco.com is not required.

Table 1 *Feature Information for DHCP High Availability Features*

Feature Name	Releases	Feature Information
ISSU--DHCP Server	12.2(31)SB2	The DHCP server has been enhanced to support ISSU.
	12.2(33)SRC	
	Cisco IOS XE Release 2.1	
SSO--DHCP Server	12.2(31)SB2	The DHCP server has been enhanced to support SSO.
	12.2(33)SRB	
	Cisco IOS XE Release 2.1	
ISSU--DHCP Relay on Unnumbered Interface	12.2(31)SB2	The DHCP relay on unnumbered interface has been enhanced to support ISSU.
	12.2(33)SRC	
SSO--DHCP Relay on Unnumbered Interface	12.2(31)SB2	The DHCP relay on unnumbered interface has been enhanced to support SSO.
	12.2(33)SRB	
ISSU--DHCP Proxy Client	12.2(31)SB2	The DHCP proxy client has been enhanced to support ISSU.
	12.2(33)SRC	
SSO--DHCP Proxy Client	12.2(31)SB2	The DHCP proxy client has been enhanced to support SSO.
	12.2(33)SRC	

Feature Name	Releases	Feature Information
ISSU--DHCP ODAP Client and Server	12.2(31)SB2 12.2(33)SRC	The DHCP ODAP client and server have been enhanced to support ISSU.
SSO--DHCP ODAP Client and Server	12.2(31)SB2 12.2(33)SRC	The DHCP ODAP client and server have been enhanced to support SSO.

Glossary

CPE --customer premises equipment. Terminating equipment, such as terminals, telephones, and modems, supplied by the service provider, installed at customer sites, and connected to the network.

DSLAM --digital subscriber line access multiplexer. A device that connects many digital subscriber lines to a network by multiplexing the DSL traffic onto one or more network trunk lines.

ISSU --In Service Software Upgrade. ISSU is a process that allows Cisco IOS software to be updated or otherwise modified while packet forwarding continues.

ODAP --On-Demand Address Pool. ODAPs enable pools of IP addresses to be dynamically increased or reduced in size depending on the address utilization level. Once configured, the ODAP is populated with one or more subnets leased from a source server and is ready to serve address requests from DHCP clients or from PPP sessions.

RP --Route Processor. A generic term for the centralized control unit in a chassis.

SSO --Stateful Switchover. SSO refers to the implementation of Cisco IOS software that allows applications and features to maintain a defined state between an active and standby RP. When a switching occurs, forwarding and sessions are maintained. SSO makes an RP failure undetectable to the network.



Note

See [Internetworking Terms and Acronyms](#) for terms not included in this glossary.

Cisco and the Cisco logo are trademarks or registered trademarks of Cisco and/or its affiliates in the U.S. and other countries. To view a list of Cisco trademarks, go to this URL: www.cisco.com/go/trademarks. Third-party trademarks mentioned are the property of their respective owners. The use of the word partner does not imply a partnership relationship between Cisco and any other company. (1110R)

Any Internet Protocol (IP) addresses and phone numbers used in this document are not intended to be actual addresses and phone numbers. Any examples, command display output, network topology diagrams, and other figures included in the document are shown for illustrative purposes only. Any use of actual IP addresses or phone numbers in illustrative content is unintentional and coincidental.

© 2011 Cisco Systems, Inc. All rights reserved.