



Install the Appliance

- [Appliance Installation Workflow, on page 1](#)
- [Unpack and Inspect the Appliance, on page 1](#)
- [Review the Installation Warnings and Guidelines, on page 2](#)
- [Review the Rack Requirements, on page 3](#)
- [Connect and Power On the Appliance, on page 3](#)
- [Check the LEDs, on page 4](#)

Appliance Installation Workflow

Complete the tasks described in this chapter to physically install your Cisco DNA Center appliance. Complete these tasks for each appliance you want to install, and be sure to install all of the appliances before configuring the primary node.

Unpack and Inspect the Appliance



Caution When handling internal appliance components, wear an ESD strap and handle modules by the carrier edges only.

-
- Step 1** Remove the appliance from its cardboard container and save all the packaging material (in case the appliance requires shipping in the future).
- Step 2** Compare the shipment with the equipment list provided by your customer service representative. Verify that you have all the items.
- Step 3** Check for damage and report discrepancies or damage, if any, to your customer service representative immediately. Have the following information ready:
- Invoice number of the shipper (see the packing slip)
 - Model and serial number of the damaged unit
 - Description of damage

- Effect of damage on the installation

Review the Installation Warnings and Guidelines



Warning To prevent the system from overheating, do not operate it in an area that exceeds the maximum recommended ambient temperature of: 95°F (35°C). Statement 1047



Warning The plug-socket combination must be accessible at all times, because it serves as the main disconnecting device. Statement 1019



Warning This product relies on the building's installation for short-circuit (overcurrent) protection. Ensure that the protective device is rated not greater than: 250 V, 15 A. Statement 1005



Warning Installation of the equipment must comply with local and national electrical codes. Statement 1074



Caution To ensure proper airflow it is necessary to rack the appliances using rail kits. Physically placing the units on top of one another or “stacking” without the use of the rail kits blocks the air vents on top of the appliances, which could result in overheating, higher fan speeds, and higher power consumption. We recommend that you mount your appliances on rail kits when you are installing them into the rack because these rails provide the minimal spacing required between the appliances. No additional spacing between the appliances is required when you mount the units using rail kits.



Caution Avoid uninterruptible power supply (UPS) types that use ferroresonant technology. These UPS types can become unstable with systems such as the Cisco UCS, which can have substantial current-draw fluctuations due to fluctuating data traffic patterns.

When you are installing an appliance, follow these guidelines:

- Plan your site configuration and prepare the site before installing the appliance. See the [Cisco UCS Site Preparation Guide](#) for help with recommended site planning and preparation tasks.
- Ensure that there is adequate space around the appliance to allow for servicing the appliance and for adequate airflow. The airflow in this appliance is from front to back.
- Ensure that the site air-conditioning meets the thermal requirements listed in the [Environmental Specifications](#).

- Ensure that the cabinet or rack meets the requirements listed in [Review the Rack Requirements, on page 3](#)
- Ensure that the site power meets the requirements listed in [Power Specifications](#). If available, you can use a UPS to protect against power failures.

Review the Rack Requirements

For proper operation, the rack in which you install the appliance must meet the following requirements:

- A standard 19-in. (48.3-cm) wide, four-post EIA rack, with mounting posts that conform to English universal hole spacing, per section 1 of ANSI/EIA-310-D-1992.
- The rack post holes can be square 0.38-in. (9.6 mm), round 0.28-in. (7.1 mm), #12-24 UNC, or #10-32 UNC when you use the supplied slide rails.
- The minimum vertical rack space per server must be one RU, equal to 1.75 in. (44.45 mm).

Connect and Power On the Appliance

This section describes how to power on the appliance and check that it is functional.

Step 1 Attach the supplied power cord to each power supply in the appliance and then attach the power cords to a grounded AC power outlet. See [Power Specifications](#) for details.

Wait for approximately two minutes to let the appliance boot into standby power mode during the first boot up.

You can verify the power status by looking at the Power Status LED:

- Off—There is no AC power present in the appliance.
- Amber—The appliance is in standby power mode. Power is supplied only to the CIMC and some motherboard functions.
- Green—The appliance is in main power mode. Power is supplied to all appliance components.

For more information on these and other appliance LEDs, see [Front and Rear Panels](#).

Step 2 Connect a USB keyboard and VGA monitor to the server, using the supplied KVM cable connected to the KVM connector on the front panel. Alternatively, you can use the VGA and USB ports on the rear panel. You can only connect to one VGA interface at a time.

What to do next

Continue by following the procedure described in [Check the LEDs](#).

Check the LEDs

After you have powered up the Cisco DNA Center appliance, check the state of the front-panel and rear-panel LEDs and buttons to ensure it is functioning.

The following illustrations show the LEDs for a functional appliance after physical installation and first power-up and before configuration.

Figure 1: Front Panel LEDs

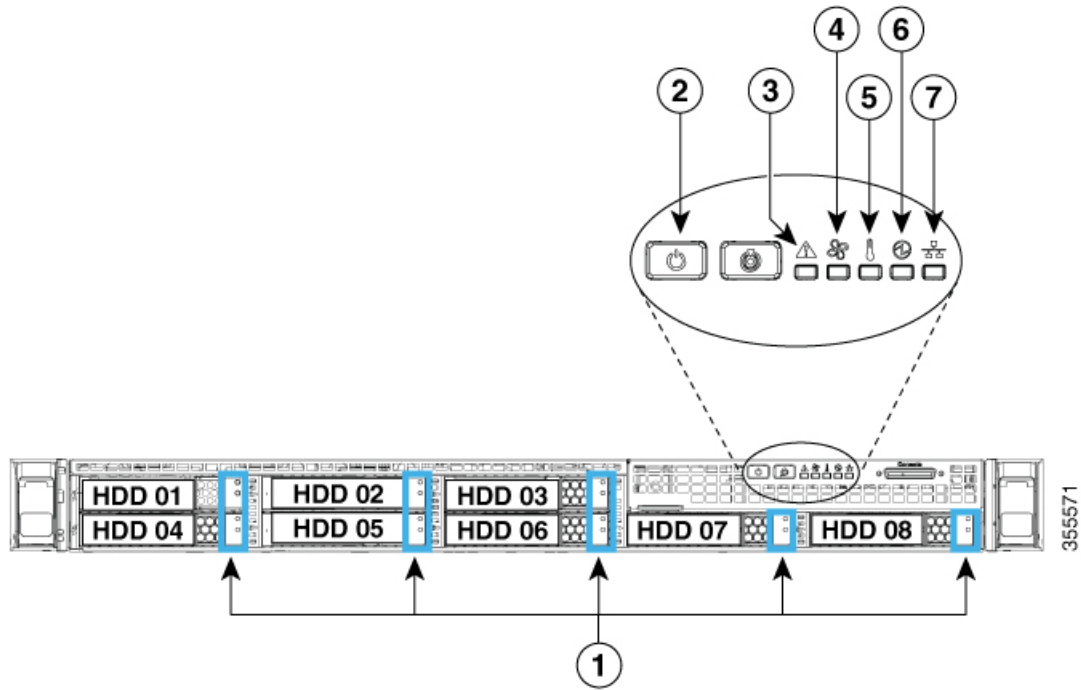

LED	Desired Status Indicator
1	Drive Fault LEDs: Off. Drive Activity LEDs: Green
2	Power Status: Green
3	System Status: Green
4	Fan Status: Green
5	Temperature Status: Green
6	Power Supply Status: Green
7	Network Link Activity: Off

Figure 2: Rear Panel LEDs

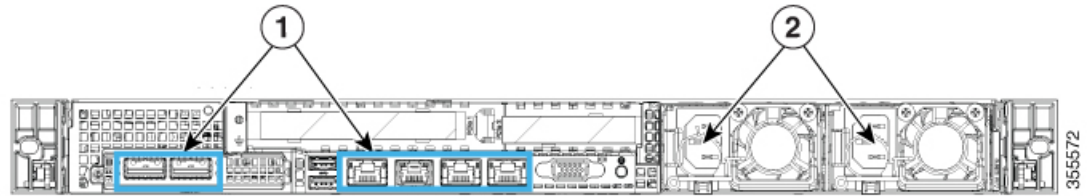

LED	Desired Status Indicator
1	<p>After initial power-up, all the ports should have their Link Status and Link Speed LEDs showing as off, and their Power Status LED should be green.</p> <p>After network settings are configured and tested using the Maglev Configuration Wizard (see Configure the Primary Node and Configure a Secondary Node), the Link Status, Link Speed and Power Status LEDs for all cabled ports should be green. All uncabled port LEDs should be unchanged.</p>
2	<p>Power Supply Fault LEDs: Off.</p> <p>AC Power LEDs: Green</p>

If you see LEDs with colors other than those shown above, you may have a problem condition. See [Front and Rear Panels](#) for details on the likely causes of the status. Be sure to correct any problem conditions before proceeding to configure the appliance.

