



Catalyst 2960 Switch Software Configuration Guide

Cisco IOS Release 12.2(40)SE
Revised September 2007

Americas Headquarters

Cisco Systems, Inc.
170 West Tasman Drive
San Jose, CA 95134-1706
USA
<http://www.cisco.com>
Tel: 408 526-4000
800 553-NETS (6387)
Fax: 408 527-0883

Text Part Number: OL-8603-04

THE SPECIFICATIONS AND INFORMATION REGARDING THE PRODUCTS IN THIS MANUAL ARE SUBJECT TO CHANGE WITHOUT NOTICE. ALL STATEMENTS, INFORMATION, AND RECOMMENDATIONS IN THIS MANUAL ARE BELIEVED TO BE ACCURATE BUT ARE PRESENTED WITHOUT WARRANTY OF ANY KIND, EXPRESS OR IMPLIED. USERS MUST TAKE FULL RESPONSIBILITY FOR THEIR APPLICATION OF ANY PRODUCTS.

THE SOFTWARE LICENSE AND LIMITED WARRANTY FOR THE ACCOMPANYING PRODUCT ARE SET FORTH IN THE INFORMATION PACKET THAT SHIPPED WITH THE PRODUCT AND ARE INCORPORATED HEREIN BY THIS REFERENCE. IF YOU ARE UNABLE TO LOCATE THE SOFTWARE LICENSE OR LIMITED WARRANTY, CONTACT YOUR CISCO REPRESENTATIVE FOR A COPY.

The Cisco implementation of TCP header compression is an adaptation of a program developed by the University of California, Berkeley (UCB) as part of UCB's public domain version of the UNIX operating system. All rights reserved. Copyright © 1981, Regents of the University of California.

NOTWITHSTANDING ANY OTHER WARRANTY HEREIN, ALL DOCUMENT FILES AND SOFTWARE OF THESE SUPPLIERS ARE PROVIDED "AS IS" WITH ALL FAULTS. CISCO AND THE ABOVE-NAMED SUPPLIERS DISCLAIM ALL WARRANTIES, EXPRESSED OR IMPLIED, INCLUDING, WITHOUT LIMITATION, THOSE OF MERCHANTABILITY, FITNESS FOR A PARTICULAR PURPOSE AND NONINFRINGEMENT OR ARISING FROM A COURSE OF DEALING, USAGE, OR TRADE PRACTICE.

IN NO EVENT SHALL CISCO OR ITS SUPPLIERS BE LIABLE FOR ANY INDIRECT, SPECIAL, CONSEQUENTIAL, OR INCIDENTAL DAMAGES, INCLUDING, WITHOUT LIMITATION, LOST PROFITS OR LOSS OR DAMAGE TO DATA ARISING OUT OF THE USE OR INABILITY TO USE THIS MANUAL, EVEN IF CISCO OR ITS SUPPLIERS HAVE BEEN ADVISED OF THE POSSIBILITY OF SUCH DAMAGES.

CCVP, the Cisco logo, and the Cisco Square Bridge logo are trademarks of Cisco Systems, Inc.; Changing the Way We Work, Live, Play, and Learn is a service mark of Cisco Systems, Inc.; and Access Registrar, Aironet, BPX, Catalyst, CCDA, CCDP, CCIE, CCIP, CCNA, CCNP, CCSP, Cisco, the Cisco Certified Internetwork Expert logo, Cisco IOS, Cisco Press, Cisco Systems, Cisco Systems Capital, the Cisco Systems logo, Cisco Unity, Enterprise/Solver, EtherChannel, EtherFast, EtherSwitch, Fast Step, Follow Me Browsing, FormShare, GigaDrive, HomeLink, Internet Quotient, IOS, iPhone, IP/TV, iQ Expertise, the iQ logo, iQ Net Readiness Scorecard, iQuick Study, LightStream, Linksys, MeetingPlace, MGX, Networking Academy, Network Registrar, PIX, ProConnect, ScriptShare, SMARTnet, StackWise, The Fastest Way to Increase Your Internet Quotient, and TransPath are registered trademarks of Cisco Systems, Inc. and/or its affiliates in the United States and certain other countries.

All other trademarks mentioned in this document or Website are the property of their respective owners. The use of the word partner does not imply a partnership relationship between Cisco and any other company. (0708R)

Any Internet Protocol (IP) addresses used in this document are not intended to be actual addresses. Any examples, command display output, and figures included in the document are shown for illustrative purposes only. Any use of actual IP addresses in illustrative content is unintentional and coincidental.

Catalyst 2960 Switch Software Configuration Guide

© 2006-2007 Cisco Systems, Inc. All rights reserved.



CONTENTS

Preface xxix

Audience xxix

Purpose xxix

Conventions xxx

Related Publications xxx

Obtaining Documentation, Obtaining Support, and Security Guidelines xxxii

CHAPTER 1

Overview 1-1

Features 1-1

Ease-of-Deployment and Ease-of-Use Features 1-1

Performance Features 1-2

Management Options 1-3

Manageability Features 1-4

Availability and Redundancy Features 1-6

VLAN Features 1-7

Security Features 1-7

QoS and CoS Features 1-9

Monitoring Features 1-10

Default Settings After Initial Switch Configuration 1-10

Network Configuration Examples 1-12

Design Concepts for Using the Switch 1-12

Small to Medium-Sized Network Using Catalyst 2960 Switches 1-16

Long-Distance, High-Bandwidth Transport Configuration 1-17

Where to Go Next 1-18

CHAPTER 2

Using the Command-Line Interface 2-1

Understanding Command Modes 2-1

Understanding the Help System 2-3

Understanding Abbreviated Commands 2-4

Understanding no and default Forms of Commands 2-4

Understanding CLI Error Messages 2-5

Using Configuration Logging 2-5

- Using Command History 2-6
 - Changing the Command History Buffer Size 2-6
 - Recalling Commands 2-6
 - Disabling the Command History Feature 2-7
- Using Editing Features 2-7
 - Enabling and Disabling Editing Features 2-7
 - Editing Commands through Keystrokes 2-7
 - Editing Command Lines that Wrap 2-9
- Searching and Filtering Output of show and more Commands 2-10
- Accessing the CLI 2-10
 - Accessing the CLI through a Console Connection or through Telnet 2-10

CHAPTER 3

Assigning the Switch IP Address and Default Gateway 3-1

- Understanding the Boot Process 3-1
- Assigning Switch Information 3-2
 - Default Switch Information 3-3
 - Understanding DHCP-Based Autoconfiguration 3-3
 - DHCP Client Request Process 3-4
 - Configuring DHCP-Based Autoconfiguration 3-5
 - DHCP Server Configuration Guidelines 3-5
 - Configuring the TFTP Server 3-6
 - Configuring the DNS 3-6
 - Configuring the Relay Device 3-6
 - Obtaining Configuration Files 3-7
 - Example Configuration 3-8
 - Manually Assigning IP Information 3-10
- Checking and Saving the Running Configuration 3-10
- Modifying the Startup Configuration 3-11
 - Default Boot Configuration 3-12
 - Automatically Downloading a Configuration File 3-12
 - Specifying the Filename to Read and Write the System Configuration 3-12
 - Booting Manually 3-13
 - Booting a Specific Software Image 3-14
 - Controlling Environment Variables 3-14
- Scheduling a Reload of the Software Image 3-16
 - Configuring a Scheduled Reload 3-16
 - Displaying Scheduled Reload Information 3-17

CHAPTER 4**Configuring Cisco IOS CNS Agents 4-1**

- Understanding Cisco Configuration Engine Software 4-1
 - Configuration Service 4-2
 - Event Service 4-3
 - NameSpace Mapper 4-3
 - What You Should Know About the CNS IDs and Device Hostnames 4-3
 - ConfigID 4-3
 - DeviceID 4-4
 - Hostname and DeviceID 4-4
 - Using Hostname, DeviceID, and ConfigID 4-4
- Understanding Cisco IOS Agents 4-5
 - Initial Configuration 4-5
 - Incremental (Partial) Configuration 4-6
 - Synchronized Configuration 4-6
- Configuring Cisco IOS Agents 4-6
 - Enabling Automated CNS Configuration 4-6
 - Enabling the CNS Event Agent 4-8
 - Enabling the Cisco IOS CNS Agent 4-9
 - Enabling an Initial Configuration 4-9
 - Enabling a Partial Configuration 4-11
- Displaying CNS Configuration 4-12

CHAPTER 5**Clustering Switches 5-1**

- Understanding Switch Clusters 5-1
 - Cluster Command Switch Characteristics 5-3
 - Standby Cluster Command Switch Characteristics 5-3
 - Candidate Switch and Cluster Member Switch Characteristics 5-3
- Planning a Switch Cluster 5-4
 - Automatic Discovery of Cluster Candidates and Members 5-4
 - Discovery Through CDP Hops 5-5
 - Discovery Through Non-CDP-Capable and Noncluster-Capable Devices 5-6
 - Discovery Through Different VLANs 5-6
 - Discovery Through Different Management VLANs 5-7
 - Discovery of Newly Installed Switches 5-8
 - HSRP and Standby Cluster Command Switches 5-9
 - Virtual IP Addresses 5-10
 - Other Considerations for Cluster Standby Groups 5-10
 - Automatic Recovery of Cluster Configuration 5-11
- IP Addresses 5-12

- Hostnames 5-12
- Passwords 5-13
- SNMP Community Strings 5-13
- TACACS+ and RADIUS 5-14
- LRE Profiles 5-14
- Using the CLI to Manage Switch Clusters 5-14
 - Catalyst 1900 and Catalyst 2820 CLI Considerations 5-14
- Using SNMP to Manage Switch Clusters 5-15

CHAPTER 6

Administering the Switch 6-1

- Managing the System Time and Date 6-1
 - Understanding the System Clock 6-1
 - Understanding Network Time Protocol 6-2
 - Configuring NTP 6-3
 - Default NTP Configuration 6-4
 - Configuring NTP Authentication 6-4
 - Configuring NTP Associations 6-5
 - Configuring NTP Broadcast Service 6-6
 - Configuring NTP Access Restrictions 6-8
 - Configuring the Source IP Address for NTP Packets 6-10
 - Displaying the NTP Configuration 6-11
 - Configuring Time and Date Manually 6-11
 - Setting the System Clock 6-11
 - Displaying the Time and Date Configuration 6-12
 - Configuring the Time Zone 6-12
 - Configuring Summer Time (Daylight Saving Time) 6-13
- Configuring a System Name and Prompt 6-14
 - Default System Name and Prompt Configuration 6-15
 - Configuring a System Name 6-15
 - Understanding DNS 6-15
 - Default DNS Configuration 6-16
 - Setting Up DNS 6-16
 - Displaying the DNS Configuration 6-17
- Creating a Banner 6-17
 - Default Banner Configuration 6-17
 - Configuring a Message-of-the-Day Login Banner 6-18
 - Configuring a Login Banner 6-19
- Managing the MAC Address Table 6-19
 - Building the Address Table 6-20

MAC Addresses and VLANs	6-20
Default MAC Address Table Configuration	6-21
Changing the Address Aging Time	6-21
Removing Dynamic Address Entries	6-22
Configuring MAC Address Notification Traps	6-22
Adding and Removing Static Address Entries	6-24
Configuring Unicast MAC Address Filtering	6-25
Displaying Address Table Entries	6-26
Managing the ARP Table	6-26

CHAPTER 7**Configuring SDM Templates 7-1**

Understanding the SDM Templates	7-1
Configuring the Switch SDM Template	7-2
Default SDM Template	7-2
SDM Template Configuration Guidelines	7-2
Setting the SDM Template	7-2
Displaying the SDM Templates	7-3

CHAPTER 8**Configuring Switch-Based Authentication 8-1**

Preventing Unauthorized Access to Your Switch	8-1
Protecting Access to Privileged EXEC Commands	8-2
Default Password and Privilege Level Configuration	8-2
Setting or Changing a Static Enable Password	8-3
Protecting Enable and Enable Secret Passwords with Encryption	8-3
Disabling Password Recovery	8-5
Setting a Telnet Password for a Terminal Line	8-6
Configuring Username and Password Pairs	8-6
Configuring Multiple Privilege Levels	8-7
Setting the Privilege Level for a Command	8-8
Changing the Default Privilege Level for Lines	8-9
Logging into and Exiting a Privilege Level	8-9
Controlling Switch Access with TACACS+	8-10
Understanding TACACS+	8-10
TACACS+ Operation	8-12
Configuring TACACS+	8-12
Default TACACS+ Configuration	8-13
Identifying the TACACS+ Server Host and Setting the Authentication Key	8-13
Configuring TACACS+ Login Authentication	8-14
Configuring TACACS+ Authorization for Privileged EXEC Access and Network Services	8-16

- Starting TACACS+ Accounting 8-17
- Displaying the TACACS+ Configuration 8-17
- Controlling Switch Access with RADIUS 8-17
 - Understanding RADIUS 8-18
 - RADIUS Operation 8-19
 - Configuring RADIUS 8-19
 - Default RADIUS Configuration 8-20
 - Identifying the RADIUS Server Host 8-20
 - Configuring RADIUS Login Authentication 8-23
 - Defining AAA Server Groups 8-25
 - Configuring RADIUS Authorization for User Privileged Access and Network Services 8-27
 - Starting RADIUS Accounting 8-28
 - Configuring Settings for All RADIUS Servers 8-29
 - Configuring the Switch to Use Vendor-Specific RADIUS Attributes 8-29
 - Configuring the Switch for Vendor-Proprietary RADIUS Server Communication 8-31
 - Displaying the RADIUS Configuration 8-31
- Configuring the Switch for Local Authentication and Authorization 8-32
- Configuring the Switch for Secure Shell 8-33
 - Understanding SSH 8-33
 - SSH Servers, Integrated Clients, and Supported Versions 8-33
 - Limitations 8-34
 - Configuring SSH 8-34
 - Configuration Guidelines 8-34
 - Setting Up the Switch to Run SSH 8-35
 - Configuring the SSH Server 8-36
 - Displaying the SSH Configuration and Status 8-37
- Configuring the Switch for Secure Socket Layer HTTP 8-37
 - Understanding Secure HTTP Servers and Clients 8-37
 - Certificate Authority Trustpoints 8-38
 - CipherSuites 8-39
 - Configuring Secure HTTP Servers and Clients 8-40
 - Default SSL Configuration 8-40
 - SSL Configuration Guidelines 8-40
 - Configuring a CA Trustpoint 8-40
 - Configuring the Secure HTTP Server 8-41
 - Configuring the Secure HTTP Client 8-43
 - Displaying Secure HTTP Server and Client Status 8-43
- Configuring the Switch for Secure Copy Protocol 8-43
 - Information About Secure Copy 8-44

Configuring IEEE 802.1x Port-Based Authentication	9-1
Understanding IEEE 802.1x Port-Based Authentication	9-1
Device Roles	9-2
Authentication Process	9-3
Authentication Initiation and Message Exchange	9-5
Ports in Authorized and Unauthorized States	9-7
IEEE 802.1x Host Mode	9-7
IEEE 802.1x Accounting	9-8
IEEE 802.1x Accounting Attribute-Value Pairs	9-8
Using IEEE 802.1x Authentication with VLAN Assignment	9-9
Using IEEE 802.1x Authentication with Guest VLAN	9-11
Using IEEE 802.1x Authentication with Restricted VLAN	9-12
Using IEEE 802.1x Authentication with Inaccessible Authentication Bypass	9-13
Using IEEE 802.1x Authentication with Voice VLAN Ports	9-14
Using IEEE 802.1x Authentication with Port Security	9-14
Using IEEE 802.1x Authentication with Wake-on-LAN	9-15
Using IEEE 802.1x Authentication with MAC Authentication Bypass	9-16
Using Network Admission Control Layer 2 IEEE 802.1x Validation	9-17
Using Web Authentication	9-17
Web Authentication with Automatic MAC Check	9-18
Configuring IEEE 802.1x Authentication	9-18
Default IEEE 802.1x Authentication Configuration	9-19
IEEE 802.1x Authentication Configuration Guidelines	9-20
IEEE 802.1x Authentication	9-20
VLAN Assignment, Guest VLAN, Restricted VLAN, and Inaccessible Authentication Bypass	9-21
MAC Authentication Bypass	9-22
Upgrading from a Previous Software Release	9-22
Configuring IEEE 802.1x Authentication	9-22
Configuring the Switch-to-RADIUS-Server Communication	9-24
Configuring the Host Mode	9-25
Configuring Periodic Re-Authentication	9-25
Manually Re-Authenticating a Client Connected to a Port	9-26
Changing the Quiet Period	9-26
Changing the Switch-to-Client Retransmission Time	9-27
Setting the Switch-to-Client Frame-Retransmission Number	9-28
Setting the Re-Authentication Number	9-28
Configuring IEEE 802.1x Accounting	9-29
Configuring a Guest VLAN	9-30
Configuring a Restricted VLAN	9-31

- Configuring the Inaccessible Authentication Bypass Feature 9-33
- Configuring IEEE 802.1x Authentication with WoL 9-35
- Configuring MAC Authentication Bypass 9-36
- Configuring NAC Layer 2 IEEE 802.1x Validation 9-37
- Configuring Web Authentication 9-38
- Disabling IEEE 802.1x Authentication on the Port 9-40
- Resetting the IEEE 802.1x Authentication Configuration to the Default Values 9-41
- Displaying IEEE 802.1x Statistics and Status 9-41

CHAPTER 10

Configuring Interface Characteristics 10-1

- Understanding Interface Types 10-1
 - Port-Based VLANs 10-2
 - Switch Ports 10-2
 - Access Ports 10-2
 - Trunk Ports 10-3
 - EtherChannel Port Groups 10-3
 - Dual-Purpose Uplink Ports 10-4
 - Connecting Interfaces 10-4
- Using Interface Configuration Mode 10-4
 - Procedures for Configuring Interfaces 10-5
 - Configuring a Range of Interfaces 10-6
 - Configuring and Using Interface Range Macros 10-7
- Configuring Ethernet Interfaces 10-9
 - Default Ethernet Interface Configuration 10-9
 - Setting the Type of a Dual-Purpose Uplink Port 10-10
 - Configuring Interface Speed and Duplex Mode 10-12
 - Speed and Duplex Configuration Guidelines 10-12
 - Setting the Interface Speed and Duplex Parameters 10-13
 - Configuring IEEE 802.3x Flow Control 10-14
 - Configuring Auto-MDIX on an Interface 10-15
 - Adding a Description for an Interface 10-16
- Configuring the System MTU 10-16
- Monitoring and Maintaining the Interfaces 10-18
 - Monitoring Interface Status 10-18
 - Clearing and Resetting Interfaces and Counters 10-19
 - Shutting Down and Restarting the Interface 10-19

CHAPTER 11

Configuring Smartports Macros 11-1

- Understanding Smartports Macros 11-1

Configuring Smartports Macros	11-2
Default Smartports Macro Configuration	11-2
Smartports Macro Configuration Guidelines	11-2
Creating Smartports Macros	11-4
Applying Smartports Macros	11-5
Applying Cisco-Default Smartports Macros	11-6
Displaying Smartports Macros	11-8

CHAPTER 12**Configuring VLANs 12-1**

Understanding VLANs	12-1
Supported VLANs	12-2
VLAN Port Membership Modes	12-3
Configuring Normal-Range VLANs	12-4
Token Ring VLANs	12-5
Normal-Range VLAN Configuration Guidelines	12-5
VLAN Configuration Mode Options	12-6
VLAN Configuration in config-vlan Mode	12-6
VLAN Configuration in VLAN Database Configuration Mode	12-6
Saving VLAN Configuration	12-6
Default Ethernet VLAN Configuration	12-7
Creating or Modifying an Ethernet VLAN	12-8
Deleting a VLAN	12-9
Assigning Static-Access Ports to a VLAN	12-10
Configuring Extended-Range VLANs	12-11
Default VLAN Configuration	12-11
Extended-Range VLAN Configuration Guidelines	12-12
Creating an Extended-Range VLAN	12-12
Displaying VLANs	12-13
Configuring VLAN Trunks	12-14
Trunking Overview	12-14
IEEE 802.1Q Configuration Considerations	12-15
Default Layer 2 Ethernet Interface VLAN Configuration	12-16
Configuring an Ethernet Interface as a Trunk Port	12-16
Interaction with Other Features	12-16
Configuring a Trunk Port	12-17
Defining the Allowed VLANs on a Trunk	12-18
Changing the Pruning-Eligible List	12-19
Configuring the Native VLAN for Untagged Traffic	12-19
Configuring Trunk Ports for Load Sharing	12-20

- Load Sharing Using STP Port Priorities 12-20
- Load Sharing Using STP Path Cost 12-22
- Configuring VMPS 12-23
 - Understanding VMPS 12-24
 - Dynamic-Access Port VLAN Membership 12-24
 - Default VMPS Client Configuration 12-25
 - VMPS Configuration Guidelines 12-25
 - Configuring the VMPS Client 12-25
 - Entering the IP Address of the VMPS 12-26
 - Configuring Dynamic-Access Ports on VMPS Clients 12-26
 - Reconfirming VLAN Memberships 12-27
 - Changing the Reconfirmation Interval 12-27
 - Changing the Retry Count 12-28
 - Monitoring the VMPS 12-28
 - Troubleshooting Dynamic-Access Port VLAN Membership 12-29
 - VMPS Configuration Example 12-29

CHAPTER 13

Configuring VTP 13-1

- Understanding VTP 13-1
 - The VTP Domain 13-2
 - VTP Modes 13-3
 - VTP Advertisements 13-3
 - VTP Version 2 13-4
 - VTP Pruning 13-4
- Configuring VTP 13-6
 - Default VTP Configuration 13-6
 - VTP Configuration Options 13-7
 - VTP Configuration in Global Configuration Mode 13-7
 - VTP Configuration in VLAN Database Configuration Mode 13-7
 - VTP Configuration Guidelines 13-8
 - Domain Names 13-8
 - Passwords 13-8
 - VTP Version 13-8
 - Configuration Requirements 13-9
 - Configuring a VTP Server 13-9
 - Configuring a VTP Client 13-11
 - Disabling VTP (VTP Transparent Mode) 13-12
 - Enabling VTP Version 2 13-13
 - Enabling VTP Pruning 13-14

Adding a VTP Client Switch to a VTP Domain	13-14
Monitoring VTP	13-16

CHAPTER 14**Configuring Voice VLAN 14-1**

Understanding Voice VLAN	14-1
Cisco IP Phone Voice Traffic	14-2
Cisco IP Phone Data Traffic	14-2
Configuring Voice VLAN	14-3
Default Voice VLAN Configuration	14-3
Voice VLAN Configuration Guidelines	14-3
Configuring a Port Connected to a Cisco 7960 IP Phone	14-4
Configuring Cisco IP Phone Voice Traffic	14-4
Configuring the Priority of Incoming Data Frames	14-6
Displaying Voice VLAN	14-6

CHAPTER 15**Configuring STP 15-1**

Understanding Spanning-Tree Features	15-1
STP Overview	15-2
Spanning-Tree Topology and BPDUs	15-3
Bridge ID, Switch Priority, and Extended System ID	15-4
Spanning-Tree Interface States	15-4
Blocking State	15-6
Listening State	15-6
Learning State	15-6
Forwarding State	15-6
Disabled State	15-7
How a Switch or Port Becomes the Root Switch or Root Port	15-7
Spanning Tree and Redundant Connectivity	15-8
Spanning-Tree Address Management	15-8
Accelerated Aging to Retain Connectivity	15-8
Spanning-Tree Modes and Protocols	15-9
Supported Spanning-Tree Instances	15-9
Spanning-Tree Interoperability and Backward Compatibility	15-10
STP and IEEE 802.1Q Trunks	15-10
Configuring Spanning-Tree Features	15-10
Default Spanning-Tree Configuration	15-11
Spanning-Tree Configuration Guidelines	15-12
Changing the Spanning-Tree Mode.	15-13
Disabling Spanning Tree	15-14

- Configuring the Root Switch 15-14
- Configuring a Secondary Root Switch 15-16
- Configuring Port Priority 15-16
- Configuring Path Cost 15-18
- Configuring the Switch Priority of a VLAN 15-19
- Configuring Spanning-Tree Timers 15-20
 - Configuring the Hello Time 15-20
 - Configuring the Forwarding-Delay Time for a VLAN 15-21
 - Configuring the Maximum-Aging Time for a VLAN 15-21
 - Configuring the Transmit Hold-Count 15-22
- Displaying the Spanning-Tree Status 15-22

CHAPTER 16

Configuring MSTP 16-1

- Understanding MSTP 16-2
 - Multiple Spanning-Tree Regions 16-2
 - IST, CIST, and CST 16-3
 - Operations Within an MST Region 16-3
 - Operations Between MST Regions 16-4
 - IEEE 802.1s Terminology 16-5
 - Hop Count 16-5
 - Boundary Ports 16-6
 - IEEE 802.1s Implementation 16-6
 - Port Role Naming Change 16-7
 - Interoperation Between Legacy and Standard Switches 16-7
 - Detecting Unidirectional Link Failure 16-8
 - Interoperability with IEEE 802.1D STP 16-8
- Understanding RSTP 16-8
 - Port Roles and the Active Topology 16-9
 - Rapid Convergence 16-10
 - Synchronization of Port Roles 16-11
 - Bridge Protocol Data Unit Format and Processing 16-12
 - Processing Superior BPDU Information 16-13
 - Processing Inferior BPDU Information 16-13
 - Topology Changes 16-13
- Configuring MSTP Features 16-14
 - Default MSTP Configuration 16-14
 - MSTP Configuration Guidelines 16-15
 - Specifying the MST Region Configuration and Enabling MSTP 16-16
 - Configuring the Root Switch 16-17

Configuring a Secondary Root Switch	16-18
Configuring Port Priority	16-19
Configuring Path Cost	16-20
Configuring the Switch Priority	16-21
Configuring the Hello Time	16-22
Configuring the Forwarding-Delay Time	16-23
Configuring the Maximum-Aging Time	16-23
Configuring the Maximum-Hop Count	16-24
Specifying the Link Type to Ensure Rapid Transitions	16-24
Designating the Neighbor Type	16-25
Restarting the Protocol Migration Process	16-25
Displaying the MST Configuration and Status	16-26

CHAPTER 17**Configuring Optional Spanning-Tree Features 17-1**

Understanding Optional Spanning-Tree Features	17-1
Understanding Port Fast	17-2
Understanding BPDU Guard	17-2
Understanding BPDU Filtering	17-3
Understanding UplinkFast	17-3
Understanding BackboneFast	17-5
Understanding EtherChannel Guard	17-7
Understanding Root Guard	17-8
Understanding Loop Guard	17-9
Configuring Optional Spanning-Tree Features	17-9
Default Optional Spanning-Tree Configuration	17-9
Optional Spanning-Tree Configuration Guidelines	17-10
Enabling Port Fast	17-10
Enabling BPDU Guard	17-11
Enabling BPDU Filtering	17-12
Enabling UplinkFast for Use with Redundant Links	17-13
Enabling BackboneFast	17-13
Enabling EtherChannel Guard	17-14
Enabling Root Guard	17-15
Enabling Loop Guard	17-15
Displaying the Spanning-Tree Status	17-16

CHAPTER 18**Configuring IGMP Snooping and MVR 18-1**

Understanding IGMP Snooping	18-1
IGMP Versions	18-2

- Joining a Multicast Group 18-3
- Leaving a Multicast Group 18-5
- Immediate Leave 18-5
- IGMP Configurable-Leave Timer 18-5
- IGMP Report Suppression 18-6
- Configuring IGMP Snooping 18-6
 - Default IGMP Snooping Configuration 18-6
 - Enabling or Disabling IGMP Snooping 18-7
 - Setting the Snooping Method 18-8
 - Configuring a Multicast Router Port 18-9
 - Configuring a Host Statically to Join a Group 18-10
 - Enabling IGMP Immediate Leave 18-10
 - Configuring the IGMP Leave Timer 18-11
 - Configuring TCN-Related Commands 18-12
 - Controlling the Multicast Flooding Time After a TCN Event 18-12
 - Recovering from Flood Mode 18-12
 - Disabling Multicast Flooding During a TCN Event 18-13
 - Configuring the IGMP Snooping Querier 18-14
 - Disabling IGMP Report Suppression 18-15
- Displaying IGMP Snooping Information 18-15
- Understanding Multicast VLAN Registration 18-17
 - Using MVR in a Multicast Television Application 18-18
- Configuring MVR 18-19
 - Default MVR Configuration 18-19
 - MVR Configuration Guidelines and Limitations 18-20
 - Configuring MVR Global Parameters 18-20
 - Configuring MVR Interfaces 18-21
- Displaying MVR Information 18-23
- Configuring IGMP Filtering and Throttling 18-23
 - Default IGMP Filtering and Throttling Configuration 18-24
 - Configuring IGMP Profiles 18-24
 - Applying IGMP Profiles 18-25
 - Setting the Maximum Number of IGMP Groups 18-26
 - Configuring the IGMP Throttling Action 18-27
- Displaying IGMP Filtering and Throttling Configuration 18-28

CHAPTER 19

Configuring Port-Based Traffic Control 19-1

- Configuring Storm Control 19-1
- Understanding Storm Control 19-1

Default Storm Control Configuration	19-3
Configuring Storm Control and Threshold Levels	19-3
Configuring Protected Ports	19-5
Default Protected Port Configuration	19-6
Protected Port Configuration Guidelines	19-6
Configuring a Protected Port	19-6
Configuring Port Blocking	19-7
Default Port Blocking Configuration	19-7
Blocking Flooded Traffic on an Interface	19-7
Configuring Port Security	19-8
Understanding Port Security	19-8
Secure MAC Addresses	19-8
Security Violations	19-9
Default Port Security Configuration	19-10
Port Security Configuration Guidelines	19-10
Enabling and Configuring Port Security	19-11
Enabling and Configuring Port Security Aging	19-16
Displaying Port-Based Traffic Control Settings	19-17

CHAPTER 20**Configuring CDP 20-1**

Understanding CDP	20-1
Configuring CDP	20-2
Default CDP Configuration	20-2
Configuring the CDP Characteristics	20-2
Disabling and Enabling CDP	20-3
Disabling and Enabling CDP on an Interface	20-4
Monitoring and Maintaining CDP	20-4

CHAPTER 21**Configuring LLDP and LLDP-MED 21-1**

Understanding LLDP and LLDP-MED	21-1
Understanding LLDP	21-1
Understanding LLDP-MED	21-2
Configuring LLDP and LLDP-MED	21-3
Default LLDP Configuration	21-3
Configuring LLDP Characteristics	21-4
Disabling and Enabling LLDP Globally	21-5
Disabling and Enabling LLDP on an Interface	21-5
Configuring LLDP-MED TLVs	21-6

Monitoring and Maintaining LLDP and LLDP-MED 21-7

CHAPTER 22

Configuring UDLD 22-1

- Understanding UDLD 22-1
 - Modes of Operation 22-1
 - Methods to Detect Unidirectional Links 22-2
- Configuring UDLD 22-4
 - Default UDLD Configuration 22-4
 - Configuration Guidelines 22-4
 - Enabling UDLD Globally 22-5
 - Enabling UDLD on an Interface 22-5
 - Resetting an Interface Disabled by UDLD 22-6
- Displaying UDLD Status 22-6

CHAPTER 23

Configuring SPAN and RSPAN 23-1

- Understanding SPAN and RSPAN 23-1
 - Local SPAN 23-2
 - Remote SPAN 23-2
 - SPAN and RSPAN Concepts and Terminology 23-3
 - SPAN Sessions 23-3
 - Monitored Traffic 23-4
 - Source Ports 23-5
 - Source VLANs 23-6
 - VLAN Filtering 23-6
 - Destination Port 23-6
 - RSPAN VLAN 23-7
 - SPAN and RSPAN Interaction with Other Features 23-8
- Configuring SPAN and RSPAN 23-9
 - Default SPAN and RSPAN Configuration 23-9
 - Configuring Local SPAN 23-9
 - SPAN Configuration Guidelines 23-10
 - Creating a Local SPAN Session 23-10
 - Creating a Local SPAN Session and Configuring Incoming Traffic 23-13
 - Specifying VLANs to Filter 23-14
 - Configuring RSPAN 23-15
 - RSPAN Configuration Guidelines 23-16
 - Configuring a VLAN as an RSPAN VLAN 23-16
 - Creating an RSPAN Source Session 23-17
 - Creating an RSPAN Destination Session 23-19

Creating an RSPAN Destination Session and Configuring Incoming Traffic	23-20
Specifying VLANs to Filter	23-21
Displaying SPAN and RSPAN Status	23-22

CHAPTER 24**Configuring RMON 24-1**

Understanding RMON	24-1
Configuring RMON	24-2
Default RMON Configuration	24-3
Configuring RMON Alarms and Events	24-3
Collecting Group History Statistics on an Interface	24-5
Collecting Group Ethernet Statistics on an Interface	24-5
Displaying RMON Status	24-6

CHAPTER 25**Configuring System Message Logging 25-1**

Understanding System Message Logging	25-1
Configuring System Message Logging	25-2
System Log Message Format	25-2
Default System Message Logging Configuration	25-3
Disabling Message Logging	25-4
Setting the Message Display Destination Device	25-5
Synchronizing Log Messages	25-6
Enabling and Disabling Time Stamps on Log Messages	25-7
Enabling and Disabling Sequence Numbers in Log Messages	25-8
Defining the Message Severity Level	25-8
Limiting Syslog Messages Sent to the History Table and to SNMP	25-10
Enabling the Configuration-Change Logger	25-10
Configuring UNIX Syslog Servers	25-12
Logging Messages to a UNIX Syslog Daemon	25-12
Configuring the UNIX System Logging Facility	25-12
Displaying the Logging Configuration	25-13

CHAPTER 26**Configuring SNMP 26-1**

Understanding SNMP	26-1
SNMP Versions	26-2
SNMP Manager Functions	26-3
SNMP Agent Functions	26-4
SNMP Community Strings	26-4
Using SNMP to Access MIB Variables	26-4

- SNMP Notifications 26-5
- SNMP ifIndex MIB Object Values 26-6
- Configuring SNMP 26-6
 - Default SNMP Configuration 26-7
 - SNMP Configuration Guidelines 26-7
 - Disabling the SNMP Agent 26-8
 - Configuring Community Strings 26-8
 - Configuring SNMP Groups and Users 26-10
 - Configuring SNMP Notifications 26-12
 - Setting the Agent Contact and Location Information 26-15
 - Limiting TFTP Servers Used Through SNMP 26-16
 - SNMP Examples 26-17
- Displaying SNMP Status 26-18

CHAPTER 27

Configuring Cisco IOS IP SLAs Operations 27-1

- Understanding Cisco IOS IP SLAs 27-1
 - Using Cisco IOS IP SLAs to Measure Network Performance 27-2
 - IP SLAs Responder and IP SLAs Control Protocol 27-3
 - Response Time Computation for IP SLAs 27-4
- Configuring IP SLAs Operations 27-5
 - Default Configuration 27-5
 - Configuration Guidelines 27-5
 - Configuring the IP SLAs Responder 27-6
- Monitoring IP SLAs Operations 27-7

CHAPTER 28

Configuring QoS 28-1

- Understanding QoS 28-1
 - Basic QoS Model 28-3
 - Classification 28-5
 - Classification Based on QoS ACLs 28-7
 - Classification Based on Class Maps and Policy Maps 28-7
 - Policing and Marking 28-8
 - Policing on Physical Ports 28-9
 - Mapping Tables 28-11
 - Queueing and Scheduling Overview 28-12
 - Weighted Tail Drop 28-12
 - SRR Shaping and Sharing 28-13
 - Queueing and Scheduling on Ingress Queues 28-14
 - Queueing and Scheduling on Egress Queues 28-16

Packet Modification	28-18
Configuring Auto-QoS	28-19
Generated Auto-QoS Configuration	28-20
Effects of Auto-QoS on the Configuration	28-24
Auto-QoS Configuration Guidelines	28-25
Enabling Auto-QoS for VoIP	28-25
Auto-QoS Configuration Example	28-27
Displaying Auto-QoS Information	28-29
Configuring Standard QoS	28-29
Default Standard QoS Configuration	28-30
Default Ingress Queue Configuration	28-30
Default Egress Queue Configuration	28-31
Default Mapping Table Configuration	28-32
Standard QoS Configuration Guidelines	28-32
QoS ACL Guidelines	28-32
Policing Guidelines	28-32
General QoS Guidelines	28-33
Enabling QoS Globally	28-33
Configuring Classification Using Port Trust States	28-34
Configuring the Trust State on Ports within the QoS Domain	28-34
Configuring the CoS Value for an Interface	28-36
Configuring a Trusted Boundary to Ensure Port Security	28-36
Enabling DSCP Transparency Mode	28-38
Configuring the DSCP Trust State on a Port Bordering Another QoS Domain	28-38
Configuring a QoS Policy	28-40
Classifying Traffic by Using ACLs	28-41
Classifying Traffic by Using Class Maps	28-44
Classifying, Policing, and Marking Traffic on Physical Ports by Using Policy Maps	28-46
Classifying, Policing, and Marking Traffic by Using Aggregate Policers	28-49
Configuring DSCP Maps	28-51
Configuring the CoS-to-DSCP Map	28-52
Configuring the IP-Precedence-to-DSCP Map	28-53
Configuring the Policed-DSCP Map	28-54
Configuring the DSCP-to-CoS Map	28-55
Configuring the DSCP-to-DSCP-Mutation Map	28-56
Configuring Ingress Queue Characteristics	28-57
Mapping DSCP or CoS Values to an Ingress Queue and Setting WTD Thresholds	28-58
Allocating Buffer Space Between the Ingress Queues	28-59
Allocating Bandwidth Between the Ingress Queues	28-60

- Configuring the Ingress Priority Queue 28-61
- Configuring Egress Queue Characteristics 28-62
 - Configuration Guidelines 28-62
 - Allocating Buffer Space to and Setting WTD Thresholds for an Egress Queue-Set 28-62
 - Mapping DSCP or CoS Values to an Egress Queue and to a Threshold ID 28-65
 - Configuring SRR Shaped Weights on Egress Queues 28-66
 - Configuring SRR Shared Weights on Egress Queues 28-67
 - Configuring the Egress Expedite Queue 28-68
 - Limiting the Bandwidth on an Egress Interface 28-68
- Displaying Standard QoS Information 28-69

CHAPTER 29

Configuring IPv6 Host Functions 29-1

- Understanding IPv6 29-1
 - IPv6 Addresses 29-2
 - Supported IPv6 Unicast Routing Features 29-3
 - 128-Bit Wide Unicast Addresses 29-3
 - DNS for IPv6 29-4
 - ICMPv6 29-4
 - Neighbor Discovery 29-4
 - IPv6 Stateless Autoconfiguration and Duplicate Address Detection 29-4
 - IPv6 Applications 29-5
 - Dual IPv4 and IPv6 Protocol Stacks 29-5
 - SDM Templates 29-6
 - Dual IPv4-and-IPv6 SDM Templates 29-7
- Configuring IPv6 29-7
 - Default IPv6 Configuration 29-8
 - Configuring IPv6 ICMP Rate Limiting 29-8
 - Configuring Static Routes for IPv6 29-9
- Displaying IPv6 29-11

CHAPTER 30

Configuring IPv6 MLD Snooping 30-1

- Understanding MLD Snooping 30-1
 - MLD Messages 30-2
 - MLD Queries 30-3
 - Multicast Client Aging Robustness 30-3
 - Multicast Router Discovery 30-3
 - MLD Reports 30-4
 - MLD Done Messages and Immediate-Leave 30-4
 - Topology Change Notification Processing 30-5

Configuring IPv6 MLD Snooping	30-5
Default MLD Snooping Configuration	30-5
MLD Snooping Configuration Guidelines	30-6
Enabling or Disabling MLD Snooping	30-6
Configuring a Static Multicast Group	30-8
Configuring a Multicast Router Port	30-8
Enabling MLD Immediate Leave	30-9
Configuring MLD Snooping Queries	30-10
Disabling MLD Listener Message Suppression	30-11
Displaying MLD Snooping Information	30-11

CHAPTER 31**Configuring EtherChannels and Link-State Tracking 31-1**

Understanding EtherChannels	31-1
EtherChannel Overview	31-2
Port-Channel Interfaces	31-3
Port Aggregation Protocol	31-4
PAgP Modes	31-4
PAgP Interaction with Other Features	31-5
Link Aggregation Control Protocol	31-5
LACP Modes	31-5
LACP Interaction with Other Features	31-6
EtherChannel On Mode	31-6
Load Balancing and Forwarding Methods	31-6
Configuring EtherChannels	31-8
Default EtherChannel Configuration	31-9
EtherChannel Configuration Guidelines	31-9
Configuring Layer 2 EtherChannels	31-10
Configuring EtherChannel Load Balancing	31-12
Configuring the PAgP Learn Method and Priority	31-13
Configuring LACP Hot-Standby Ports	31-14
Configuring the LACP System Priority	31-15
Configuring the LACP Port Priority	31-15
Displaying EtherChannel, PAgP, and LACP Status	31-16
Understanding Link-State Tracking	31-17
Configuring Link-State Tracking	31-19
Default Link-State Tracking Configuration	31-20
Link-State Tracking Configuration Guidelines	31-20
Configuring Link-State Tracking	31-20
Displaying Link-State Tracking Status	31-21

CHAPTER 32

Troubleshooting 32-1

- Recovering from a Software Failure 32-2
- Recovering from a Lost or Forgotten Password 32-3
 - Procedure with Password Recovery Enabled 32-4
 - Procedure with Password Recovery Disabled 32-6
- Recovering from a Command Switch Failure 32-7
 - Replacing a Failed Command Switch with a Cluster Member 32-8
 - Replacing a Failed Command Switch with Another Switch 32-10
- Recovering from Lost Cluster Member Connectivity 32-11
- Preventing Autonegotiation Mismatches 32-11
- SFP Module Security and Identification 32-12
- Monitoring SFP Module Status 32-12
- Using Ping 32-12
 - Understanding Ping 32-13
 - Executing Ping 32-13
- Using Layer 2 Traceroute 32-14
 - Understanding Layer 2 Traceroute 32-14
 - Usage Guidelines 32-14
 - Displaying the Physical Path 32-15
- Using IP Traceroute 32-15
 - Understanding IP Traceroute 32-15
 - Executing IP Traceroute 32-16
- Using TDR 32-17
 - Understanding TDR 32-17
 - Running TDR and Displaying the Results 32-18
- Using Debug Commands 32-18
 - Enabling Debugging on a Specific Feature 32-18
 - Enabling All-System Diagnostics 32-19
 - Redirecting Debug and Error Message Output 32-19
- Using the show platform forward Command 32-20
- Using the crashinfo Files 32-21
 - Basic crashinfo Files 32-21
 - Extended crashinfo Files 32-22

APPENDIX A

Supported MIBs A-1

- MIB List A-1
- Using FTP to Access the MIB Files A-3

Working with the Cisco IOS File System, Configuration Files, and Software Images B-1

- Working with the Flash File System **B-1**
 - Displaying Available File Systems **B-2**
 - Setting the Default File System **B-3**
 - Displaying Information about Files on a File System **B-3**
 - Changing Directories and Displaying the Working Directory **B-4**
 - Creating and Removing Directories **B-4**
 - Copying Files **B-5**
 - Deleting Files **B-5**
 - Creating, Displaying, and Extracting tar Files **B-6**
 - Creating a tar File **B-6**
 - Displaying the Contents of a tar File **B-7**
 - Extracting a tar File **B-7**
 - Displaying the Contents of a File **B-8**
- Working with Configuration Files **B-8**
 - Guidelines for Creating and Using Configuration Files **B-9**
 - Configuration File Types and Location **B-10**
 - Creating a Configuration File By Using a Text Editor **B-10**
 - Copying Configuration Files By Using TFTP **B-10**
 - Preparing to Download or Upload a Configuration File By Using TFTP **B-10**
 - Downloading the Configuration File By Using TFTP **B-11**
 - Uploading the Configuration File By Using TFTP **B-12**
 - Copying Configuration Files By Using FTP **B-12**
 - Preparing to Download or Upload a Configuration File By Using FTP **B-13**
 - Downloading a Configuration File By Using FTP **B-13**
 - Uploading a Configuration File By Using FTP **B-14**
 - Copying Configuration Files By Using RCP **B-15**
 - Preparing to Download or Upload a Configuration File By Using RCP **B-16**
 - Downloading a Configuration File By Using RCP **B-17**
 - Uploading a Configuration File By Using RCP **B-18**
 - Clearing Configuration Information **B-19**
 - Clearing the Startup Configuration File **B-19**
 - Deleting a Stored Configuration File **B-19**
 - Replacing and Rolling Back Configurations **B-19**
 - Understanding Configuration Replacement and Rollback **B-19**
 - Configuration Guidelines **B-21**
 - Configuring the Configuration Archive **B-21**
 - Performing a Configuration Replacement or Rollback Operation **B-22**

- Working with Software Images **B-23**
 - Image Location on the Switch **B-24**
 - tar File Format of Images on a Server or Cisco.com **B-24**
 - Copying Image Files By Using TFTP **B-25**
 - Preparing to Download or Upload an Image File By Using TFTP **B-26**
 - Downloading an Image File By Using TFTP **B-27**
 - Uploading an Image File By Using TFTP **B-28**
 - Copying Image Files By Using FTP **B-29**
 - Preparing to Download or Upload an Image File By Using FTP **B-29**
 - Downloading an Image File By Using FTP **B-30**
 - Uploading an Image File By Using FTP **B-32**
 - Copying Image Files By Using RCP **B-33**
 - Preparing to Download or Upload an Image File By Using RCP **B-33**
 - Downloading an Image File By Using RCP **B-35**
 - Uploading an Image File By Using RCP **B-37**

B-38

APPENDIX C

Recommendations for Upgrading a Catalyst 2950 Switch to a Catalyst 2960 Switch C-1

- Configuration Compatibility Issues **C-1**
- Feature Behavior Incompatibilities **C-5**

APPENDIX D

Unsupported Commands in Cisco IOS Release 12.2(40)SE D-1

- Access Control Lists **D-1**
 - Unsupported Privileged EXEC Commands **D-1**
 - Unsupported Global Configuration Commands **D-1**
 - Unsupported Route-Map Configuration Commands **D-1**
- Boot Loader Commands **D-2**
 - Unsupported User EXEC Commands **D-2**
 - Unsupported Global Configuration Commands **D-2**
- Embedded Event Manager **D-2**
 - Unsupported Privileged EXEC Commands **D-2**
 - Unsupported Global Configuration Commands **D-2**
 - Unsupported Commands in Applet Configuration Mode **D-2**
- Debug Commands **D-2**
 - Unsupported Privileged EXEC Commands **D-2**
- IIGMP Snooping Commands **D-3**
 - Unsupported Global Configuration Commands **D-3**

Interface Commands	D-3
Unsupported Privileged EXEC Commands	D-3
Unsupported Global Configuration Commands	D-3
Unsupported Interface Configuration Commands	D-3
MAC Address Commands	D-3
Unsupported Privileged EXEC Commands	D-3
Unsupported Global Configuration Commands	D-4
Miscellaneous	D-4
Unsupported Privileged EXEC Commands	D-4
Unsupported Global Configuration Commands	D-4
Network Address Translation (NAT) Commands	D-4
Unsupported Privileged EXEC Commands	D-4
QoS	D-5
Unsupported Global Configuration Command	D-5
Unsupported Interface Configuration Commands	D-5
Unsupported Policy-Map Configuration Command	D-5
RADIUS	D-5
Unsupported Global Configuration Commands	D-5
SNMP	D-5
Unsupported Global Configuration Commands	D-5
Spanning Tree	D-6
Unsupported Global Configuration Command	D-6
Unsupported Interface Configuration Command	D-6
VLAN	D-6
Unsupported Global Configuration Command	D-6
Unsupported vlan-config Command	D-6
Unsupported User EXEC Commands	D-6
VTP	D-6
Unsupported Privileged EXEC Commands	D-6



Preface

Audience

This guide is for the networking professional managing the Catalyst 2960 switch, hereafter referred to as the *switch module*. Before using this guide, you should have experience working with the Cisco IOS software and be familiar with the concepts and terminology of Ethernet and local area networking.

Purpose

This guide provides the information that you need to configure Cisco IOS software features on your switch. The Catalyst 2960 software provides enterprise-class intelligent services such as access control lists (ACLs) and quality of service (QoS) features.

This guide provides procedures for using the commands that have been created or changed for use with the Catalyst 2960 switch. It does not provide detailed information about these commands. For detailed information about these commands, see the *Catalyst 2960 Switch Command Reference* for this release. For information about the standard Cisco IOS Release 12.2 commands, see the Cisco IOS documentation set available from the Cisco.com home page at **Documentation > Cisco IOS Software**.

This guide does not provide detailed information on the graphical user interfaces (GUIs) for the embedded device manager or for Cisco Network Assistant (hereafter referred to as *Network Assistant*) that you can use to manage the switch. However, the concepts in this guide are applicable to the GUI user. For information about the device manager, see the switch online help. For information about Network Assistant, see *Getting Started with Cisco Network Assistant*, available on Cisco.com.

This guide does not describe system messages you might encounter or how to install your switch. For more information, see the *Catalyst 2960 Switch System Message Guide* for this release and the *Catalyst 2960 Switch Hardware Installation Guide*.

For documentation updates, see the release notes for this release.

Conventions

This publication uses these conventions to convey instructions and information:

Command descriptions use these conventions:

- Commands and keywords are in **boldface** text.
- Arguments for which you supply values are in *italic*.
- Square brackets ([]) mean optional elements.
- Braces ({ }) group required choices, and vertical bars (|) separate the alternative elements.
- Braces and vertical bars within square brackets ({ | }) mean a required choice within an optional element.

Interactive examples use these conventions:

- Terminal sessions and system displays are in `screen` font.
- Information you enter is in **boldface screen** font.
- Nonprinting characters, such as passwords or tabs, are in angle brackets (< >).

Notes, cautions, and timesavers use these conventions and symbols:



Note

Means *reader take note*. Notes contain helpful suggestions or references to materials not contained in this manual.



Caution

Means *reader be careful*. In this situation, you might do something that could result in equipment damage or loss of data.

Related Publications

These documents provide complete information about the switch and are available from this Cisco.com site:

http://www.cisco.com/en/US/products/ps6406/tsd_products_support_series_home.html



Note

Before installing, configuring, or upgrading the switch, see these documents:

- For initial configuration information, see the “Using Express Setup” section in the getting started guide or the “Configuring the Switch with the CLI-Based Setup Program” appendix in the hardware installation guide.
- For device manager requirements, see the “System Requirements” section in the release notes (not orderable but available on Cisco.com).
- For Network Assistant requirements, see the *Getting Started with Cisco Network Assistant* (not orderable but available on Cisco.com).

- For cluster requirements, see the *Release Notes for Cisco Network Assistant* (not orderable but available on Cisco.com).
- For upgrading information, see the “Downloading Software” section in the release notes.

You can order printed copies of documents with a DOC-xxxxxx= number from the Cisco.com sites and from the telephone numbers listed in the URL referenced in the “[Obtaining Documentation, Obtaining Support, and Security Guidelines](#)” section on page xxxii.

- *Release Notes for the Catalyst 3750, 3560, 2970, and 2960 Switches* (not orderable but available on Cisco.com)
- *Catalyst 3750, 3560, 3550, 2970, and 2960 Switch System Message Guide* (not orderable but available on Cisco.com)
- *Catalyst 2960 Switch Software Configuration Guide* (not orderable but available on Cisco.com)
- *Catalyst 2960 Switch Command Reference* (not orderable but available on Cisco.com)
- Device manager online help (available on the switch)
- *Catalyst 2960 Switch Hardware Installation Guide* (not orderable but available on Cisco.com)
- *Catalyst 2960 Switch Getting Started Guide* (order number DOC-7816879=)
- *Regulatory Compliance and Safety Information for the Catalyst 2960 Switch* (order number DOC-7816880=)
- *Getting Started with Cisco Network Assistant* (not orderable but available on Cisco.com)
- *Release Notes for Cisco Network Assistant* (not orderable but available on Cisco.com)
- *Cisco Small Form-Factor Pluggable Modules Installation Notes* (order number DOC-7815160=)
- *Cisco RPS 300 Redundant Power System Hardware Installation Guide* (order number DOC-7810372=)
- *Cisco RPS 675 Redundant Power System Hardware Installation Guide* (order number DOC-7815201=)
- *Cisco Redundant Power System 2300 Hardware Installation Guide* (order number DOC-7817647=)
- For more information about the Network Admission Control (NAC) features, see the *Network Admission Control Software Configuration Guide* (not orderable but available on Cisco.com)
- These compatibility matrix documents are available from this Cisco.com site:

http://www.cisco.com/en/US/products/hw/modules/ps5455/products_device_support_tables_list.html

- *Cisco Gigabit Ethernet Transceiver Modules Compatibility Matrix* (not orderable but available on Cisco.com)
- *Cisco 100-Megabit Ethernet SFP Modules Compatibility Matrix* (not orderable but available on Cisco.com)
- *Cisco Small Form-Factor Pluggable Modules Compatibility Matrix* (not orderable but available on Cisco.com)
- *Compatibility Matrix for 1000BASE-T Small Form-Factor Pluggable Modules* (not orderable but available on Cisco.com)

Obtaining Documentation, Obtaining Support, and Security Guidelines

For information on obtaining documentation, obtaining support, providing documentation feedback, security guidelines, and also recommended aliases and general Cisco documents, see the monthly *What's New in Cisco Product Documentation*, which also lists all new and revised Cisco technical documentation, at:

<http://www.cisco.com/en/US/docs/general/whatsnew/whatsnew.html>



CHAPTER 1

Overview

This chapter provides these topics about the Catalyst 2960 switch software:

- [Features, page 1-1](#)
- [Default Settings After Initial Switch Configuration, page 1-10](#)
- [Network Configuration Examples, page 1-12](#)
- [Where to Go Next, page 1-18](#)

In this document, IP refers to IP Version 4 (IPv4).

Features

Some features described in this chapter are available only on the cryptographic (supports encryption) version of the software. You must obtain authorization to use this feature and to download the cryptographic version of the software from Cisco.com. For more information, see the release notes for this release.

The switch has these features:

- [Ease-of-Deployment and Ease-of-Use Features, page 1-1](#)
- [Performance Features, page 1-2](#)
- [Management Options, page 1-3](#)
- [Manageability Features, page 1-4](#) (includes a feature requiring the cryptographic version of the software)
- [Availability and Redundancy Features, page 1-6](#)
- [VLAN Features, page 1-7](#)
- [Security Features, page 1-7](#) (includes a feature requiring the cryptographic version of the software)
- [QoS and CoS Features, page 1-9](#)
- [Monitoring Features, page 1-10](#)

Ease-of-Deployment and Ease-of-Use Features

The switch ships with these features to make the deployment and the use easier:

- Express Setup for quickly configuring a switch for the first time with basic IP information, contact information, switch and Telnet passwords, and Simple Network Management Protocol (SNMP) information through a browser-based program. For more information about Express Setup, see the getting started guide.
- User-defined and Cisco-default Smartports macros for creating custom switch configurations for simplified deployment across the network.
- An embedded device manager GUI for configuring and monitoring a single switch through a web browser. For information about launching the device manager, see the getting started guide. For more information about the device manager, see the switch online help.
- Cisco Network Assistant (hereafter referred to as *Network Assistant*) for
 - Managing communities, which are device groups like clusters, except that they can contain routers and access points and can be made more secure.
 - Simplifying and minimizing switch and switch cluster management from anywhere in your intranet.
 - Accomplishing multiple configuration tasks from a single graphical interface without needing to remember command-line interface (CLI) commands to accomplish specific tasks.
 - Interactive guide mode that guides you in configuring complex features such as VLANs, ACLs, and quality of service (QoS).
 - Configuration wizards that prompt you to provide only the minimum required information to configure complex features such as QoS priorities for traffic, priority levels for data applications, and security.
 - Downloading an image to a switch.
 - Applying actions to multiple ports and multiple switches at the same time, such as VLAN and QoS settings, inventory and statistic reports, link- and switch-level monitoring and troubleshooting, and multiple switch software upgrades.
 - Viewing a topology of interconnected devices to identify existing switch clusters and eligible switches that can join a cluster and to identify link information between switches.
 - Monitoring real-time status of a switch or multiple switches from the LEDs on the front-panel images. The system, redundant power system (RPS), and port LED colors on the images are similar to those used on the physical LEDs.
- Switch clustering technology for
 - Unified configuration, monitoring, authentication, and software upgrade of multiple, cluster-capable switches, regardless of their geographic proximity and interconnection media, including Ethernet, Fast Ethernet, Fast EtherChannel, small form-factor pluggable (SFP) modules, Gigabit Ethernet, and Gigabit EtherChannel connections. For a list of cluster-capable switches, see the release notes.
 - Automatic discovery of candidate switches and creation of clusters of up to 16 switches that can be managed through a single IP address.
 - Extended discovery of cluster candidates that are not directly connected to the command switch.

Performance Features

The switch ships with these performance features:

- Autosensing of port speed and autonegotiation of duplex mode on all switch ports for optimizing bandwidth

- Automatic-medium-dependent interface crossover (auto-MDIX) capability on 10/100 and 10/100/1000 Mb/s interfaces and on 10/100/1000 BASE-TX SFP module interfaces that enables the interface to automatically detect the required cable connection type (straight-through or crossover) and to configure the connection appropriately
- Support for up to 9000 bytes for frames that are bridged in hardware, and up to 2000 bytes for frames that are bridged by software
- IEEE 802.3x flow control on all ports (the switch does not send pause frames)
- EtherChannel for enhanced fault tolerance and for providing up to 8 Gb/s (Gigabit EtherChannel) or 800 Mb/s (Fast EtherChannel) full-duplex bandwidth among switches, routers, and servers
- Port Aggregation Protocol (PAgP) and Link Aggregation Control Protocol (LACP) for automatic creation of EtherChannel links
- Forwarding of Layer 2 packets at Gigabit line rate
- Per-port storm control for preventing broadcast, multicast, and unicast storms
- Port blocking on forwarding unknown Layer 2 unknown unicast, multicast, and bridged broadcast traffic
- Internet Group Management Protocol (IGMP) snooping for IGMP Versions 1, 2, and 3 for efficiently forwarding multimedia and multicast traffic
- IGMP report suppression for sending only one IGMP report per multicast router query to the multicast devices (supported only for IGMPv1 or IGMPv2 queries)
- IGMP snooping querier support to configure switch to generate periodic IGMP general query messages
- IPv6 host support for basic IPv6 management
- Multicast Listener Discovery (MLD) snooping to enable efficient distribution of IP version 6 (IPv6) multicast data to clients and routers in a switched network
- Multicast VLAN registration (MVR) to continuously send multicast streams in a multicast VLAN while isolating the streams from subscriber VLANs for bandwidth and security reasons
- IGMP filtering for controlling the set of multicast groups to which hosts on a switch port can belong
- IGMP throttling for configuring the action when the maximum number of entries is in the IGMP forwarding table
- IGMP leave timer for configuring the leave latency for the network
- Switch Database Management (SDM) templates for allocating system resources to maximize support for user-selected features
- Cisco IOS IP Service Level Agreements (SLAs), a part of Cisco IOS software that uses active traffic monitoring for measuring network performance Support for Cisco IOS IP Service Level Agreements (SLAs) responder that allows the system to anticipate and respond to Cisco IOS IP SLAs request packets for monitoring network performance. See the release notes for responder configuration.

Management Options

These are the options for configuring and managing the switch:

- An embedded device manager—The device manager is a GUI that is integrated in the software image. You use it to configure and to monitor a single switch. For information about launching the device manager, see the getting started guide. For more information about the device manager, see the switch online help.

- Network Assistant—Network Assistant is a network management application that can be downloaded from Cisco.com. You use it to manage a single switch, a cluster of switches, or a community of devices. For more information about Network Assistant, see *Getting Started with Cisco Network Assistant*, available on Cisco.com.
- CLI—The Cisco IOS software supports desktop- and multilayer-switching features. You can access the CLI either by connecting your management station directly to the switch console port or by using Telnet from a remote management station. For more information about the CLI, see [Chapter 2, “Using the Command-Line Interface.”](#)
- SNMP—SNMP management applications such as CiscoWorks2000 LAN Management Suite (LMS) and HP OpenView. You can manage from an SNMP-compatible management station that is running platforms such as HP OpenView or SunNet Manager. The switch supports a comprehensive set of MIB extensions and four remote monitoring (RMON) groups. For more information about using SNMP, see [Chapter 26, “Configuring SNMP.”](#)
- CNS—Cisco Networking Services is network management software that acts as a configuration service for automating the deployment and management of network devices and services. You can automate initial configurations and configuration updates by generating switch-specific configuration changes, sending them to the switch, executing the configuration change, and logging the results.

For more information about CNS, see [Chapter 4, “Configuring Cisco IOS CNS Agents.”](#)

Manageability Features

These are the manageability features:

- CNS embedded agents for automating switch management, configuration storage, and delivery
- DHCP for automating configuration of switch information (such as IP address, default gateway, hostname, and Domain Name System [DNS] and TFTP server names)
- DHCP relay for forwarding User Datagram Protocol (UDP) broadcasts, including IP address requests, from DHCP clients
- DHCP server for automatic assignment of IP addresses and other DHCP options to IP hosts
- Directed unicast requests to a DNS server for identifying a switch through its IP address and its corresponding hostname and to a TFTP server for administering software upgrades from a TFTP server
- Address Resolution Protocol (ARP) for identifying a switch through its IP address and its corresponding MAC address
- Unicast MAC address filtering to drop packets with specific source or destination MAC addresses
- Cisco Discovery Protocol (CDP) Versions 1 and 2 for network topology discovery and mapping between the switch and other Cisco devices on the network
- Link Layer Discovery Protocol (LLDP) and LLDP Media Endpoint Discovery (LLDP-MED) for interoperability with third-party IP phones
- LLDP media extensions (LLDP-MED) location TLV that provides location information from the switch to the endpoint device
- Network Time Protocol (NTP) for providing a consistent time stamp to all switches from an external source
- Cisco IOS File System (IFS) for providing a single interface to all file systems that the switch uses

- Support for Enhanced Interior Gateway Routing Protocol (EIGRP) IPv6 to utilize IPv6 transport, communicate with IPv6 peers, and advertise IPv6 routes
- Support for these IP services, making them VRF aware so that they can operate on multiple routing instances: HSRP, GLBP, uRPF, ARP, SNMP, IP SLA, TFTP, FTP, syslog, traceroute, and ping
- Configuration logging to log and to view changes to the switch configuration
- Unique device identifier to provide product identification information through a **show inventory** user EXEC command display
- In-band management access through the device manager over a Netscape Navigator or Microsoft Internet Explorer browser session
- In-band management access for up to 16 simultaneous Telnet connections for multiple CLI-based sessions over the network
- In-band management access for up to five simultaneous, encrypted Secure Shell (SSH) connections for multiple CLI-based sessions over the network (requires the cryptographic version of the software)
- In-band management access through SNMP Versions 1, 2c, and 3 get and set requests
- Out-of-band management access through the switch console port to a directly attached terminal or to a remote terminal through a serial connection or a modem
- Secure Copy Protocol (SCP) feature to provide a secure and authenticated method for copying switch configuration or switch image files (requires the cryptographic version of the software)
- Configuration replacement and rollback to replace the running configuration on a switch with any saved Cisco IOS configuration file

Availability and Redundancy Features

These are the availability and redundancy features:

- Enhanced object tracking, which separates the tracking mechanism from HSRP and creates a separate, standalone tracking process that can be used by processes other than HSRP
- UniDirectional Link Detection (UDLD) and aggressive UDLD for detecting and disabling unidirectional links on fiber-optic interfaces caused by incorrect fiber-optic wiring or port faults
- IEEE 802.1D Spanning Tree Protocol (STP) for redundant backbone connections and loop-free networks. STP has these features:
 - Up to 128 spanning-tree instances supported
 - Per-VLAN spanning-tree plus (PVST+) for load balancing across VLANs
 - Rapid PVST+ for load balancing across VLANs and providing rapid convergence of spanning-tree instances
 - UplinkFast and BackboneFast for fast convergence after a spanning-tree topology change and for achieving load balancing between redundant uplinks, including Gigabit uplinks
- IEEE 802.1s Multiple Spanning Tree Protocol (MSTP) for grouping VLANs into a spanning-tree instance and for providing multiple forwarding paths for data traffic and load balancing and rapid per-VLAN Spanning-Tree plus (rapid-PVST+) based on the IEEE 802.1w Rapid Spanning Tree Protocol (RSTP) for rapid convergence of the spanning tree by immediately changing root and designated ports to the forwarding state
- Optional spanning-tree features available in PVST+, rapid-PVST+, and MSTP mode:
 - Port Fast for eliminating the forwarding delay by enabling a port to immediately change from the blocking state to the forwarding state
 - BPDU guard for shutting down Port Fast-enabled ports that receive bridge protocol data units (BPDUs)
 - BPDU filtering for preventing a Port Fast-enabled port from sending or receiving BPDUs
 - Root guard for preventing switches outside the network core from becoming the spanning-tree root
 - Loop guard for preventing alternate or root ports from becoming designated ports because of a failure that leads to a unidirectional link
- Flex Link Layer 2 interfaces to back up one another as an alternative to STP for basic link redundancy

- Link-state tracking to mirror the state of the ports that carry upstream traffic from connected hosts and servers, and to allow the failover of the server traffic to an operational link on another Cisco Ethernet switch.
- RPS support through the Cisco RPS 300 and Cisco RPS 675 for enhancing power reliability

VLAN Features

These are the VLAN features:

- Support for up to 255 VLANs for assigning users to VLANs associated with appropriate network resources, traffic patterns, and bandwidth
- Support for VLAN IDs in the 1 to 4094 range as allowed by the IEEE 802.1Q standard
- VLAN Query Protocol (VQP) for dynamic VLAN membership
- IEEE 802.1Q trunking encapsulation on all ports for network moves, adds, and changes; management and control of broadcast and multicast traffic; and network security by establishing VLAN groups for high-security users and network resources
- Dynamic Trunking Protocol (DTP) for negotiating trunking on a link between two devices and for negotiating the type of trunking encapsulation (IEEE 802.1Q) to be used
- VLAN Trunking Protocol (VTP) and VTP pruning for reducing network traffic by restricting flooded traffic to links destined for stations receiving the traffic
- Voice VLAN for creating subnets for voice traffic from Cisco IP Phones
- VLAN 1 minimization for reducing the risk of spanning-tree loops or storms by allowing VLAN 1 to be disabled on any individual VLAN trunk link. With this feature enabled, no user traffic is sent or received on the trunk. The switch CPU continues to send and receive control protocol frames.
- VLAN Flex Link Load Balancing to provide Layer 2 redundancy without requiring Spanning Tree Protocol (STP). A pair of interfaces configured as primary and backup links can load balance traffic based on VLAN.

Security Features

The switch ships with these security features:

- IP Service Level Agreements (IP SLAs) responder support that allows the switch to be a target device for IP SLAs active traffic monitoring
- Web authentication to allow a supplicant (client) that does not support IEEE 802.1x functionality to be authenticated using a web browser
- Password-protected access (read-only and read-write access) to management interfaces (device manager, Network Assistant, and the CLI) for protection against unauthorized configuration changes
- Multilevel security for a choice of security level, notification, and resulting actions
- Static MAC addressing for ensuring security
- Protected port option for restricting the forwarding of traffic to designated ports on the same switch
- Port security option for limiting and identifying MAC addresses of the stations allowed to access the port

- VLAN aware port security option to shut down the VLAN on the port when a violation occurs, instead of shutting down the entire port.
- Port security aging to set the aging time for secure addresses on a port
- BPDU guard for shutting down a Port Fast-configured port when an invalid configuration occurs
- Standard and extended IP access control lists (ACLs) for defining inbound security policies on Layer 2 interfaces (port ACLs)
- Extended MAC access control lists for defining security policies in the inbound direction on Layer 2 interfaces
- Source and destination MAC-based ACLs for filtering non-IP traffic
- DHCP snooping to filter untrusted DHCP messages between untrusted hosts and DHCP servers
- IEEE 802.1x port-based authentication to prevent unauthorized devices (clients) from gaining access to the network. These features are supported:
 - Dynamic voice virtual LAN (VLAN) for MDA to allow a dynamic voice VLAN on an MDA-enabled port
 - VLAN assignment for restricting IEEE 802.1x-authenticated users to a specified VLAN
 - Port security for controlling access to IEEE 802.1x ports
 - Voice VLAN to permit a Cisco IP Phone to access the voice VLAN regardless of the authorized or unauthorized state of the port
 - IP phone detection enhancement to detect and recognize a Cisco IP phone.
 - Guest VLAN to provide limited services to non-IEEE 802.1x-compliant users
 - Restricted VLAN to provide limited services to users who are IEEE 802.1x compliant, but do not have the credentials to authenticate via the standard IEEE 802.1x processes
 - IEEE 802.1x accounting to track network usage
 - IEEE 802.1x with wake-on-LAN to allow dormant PCs to be powered on based on the receipt of a specific Ethernet frame
- MAC authentication bypass to authorize clients based on the client MAC address.
- Network Admission Control (NAC) Layer 2 IEEE 802.1x validation of the antivirus condition or *posture* of endpoint systems or clients before granting the devices network access.

For information about configuring NAC Layer 2 IEEE 802.1x validation, see the [“Configuring NAC Layer 2 IEEE 802.1x Validation”](#) section on page 9-37.
- TACACS+, a proprietary feature for managing network security through a TACACS server
- RADIUS for verifying the identity of, granting access to, and tracking the actions of remote users through authentication, authorization, and accounting (AAA) services
- Secure Socket Layer (SSL) Version 3.0 support for the HTTP 1.1 server authentication, encryption, and message integrity and HTTP client authentication to allow secure HTTP communications (requires the cryptographic version of the software)

QoS and CoS Features

These are the QoS and CoS features:

- Automatic QoS (auto-QoS) to simplify the deployment of existing QoS features by classifying traffic and configuring egress queues
- Classification
 - IP type-of-service/Differentiated Services Code Point (IP ToS/DSCP) and IEEE 802.1p CoS marking priorities on a per-port basis for protecting the performance of mission-critical applications
 - IP ToS/DSCP and IEEE 802.1p CoS marking based on flow-based packet classification (classification based on information in the MAC, IP, and TCP/UDP headers) for high-performance quality of service at the network edge, allowing for differentiated service levels for different types of network traffic and for prioritizing mission-critical traffic in the network
 - Trusted port states (CoS, DSCP, and IP precedence) within a QoS domain and with a port bordering another QoS domain
 - Trusted boundary for detecting the presence of a Cisco IP Phone, trusting the CoS value received, and ensuring port security
- Policing
 - Traffic-policing policies on the switch port for managing how much of the port bandwidth should be allocated to a specific traffic flow
 - In Cisco IOS Release 12.2(25)SED and later, if you configure multiple class maps for a hierarchical policy map, each class map can be associated with its own port-level (second-level) policy map. Each second-level policy map can have a different policer.
 - Aggregate policing for policing traffic flows in aggregate to restrict specific applications or traffic flows to metered, predefined rates
- Out-of-Profile
 - Out-of-profile markdown for packets that exceed bandwidth utilization limits
- Ingress queueing and scheduling
 - Two configurable ingress queues for user traffic (one queue can be the priority queue)
 - Weighted tail drop (WTD) as the congestion-avoidance mechanism for managing the queue lengths and providing drop precedences for different traffic classifications
 - Shaped round robin (SRR) as the scheduling service for specifying the rate at which packets are sent to the internal ring (sharing is the only supported mode on ingress queues)
- Egress queues and scheduling
 - Four egress queues per port
 - WTD as the congestion-avoidance mechanism for managing the queue lengths and providing drop precedences for different traffic classifications
 - SRR as the scheduling service for specifying the rate at which packets are dequeued to the egress interface (shaping or sharing is supported on egress queues). Shaped egress queues are guaranteed but limited to using a share of port bandwidth. Shared egress queues are also guaranteed a configured share of bandwidth, but can use more than the guarantee if other queues become empty and do not use their share of the bandwidth.

Monitoring Features

These are the monitoring features:

- Switch LEDs that provide port- and switch-level status
- MAC address notification traps and RADIUS accounting for tracking users on a network by storing the MAC addresses that the switch has learned or removed
- Switched Port Analyzer (SPAN) and Remote SPAN (RSPAN) for traffic monitoring on any port or VLAN
- SPAN and RSPAN support of Intrusion Detection Systems (IDS) to monitor, repel, and report network security violations
- Four groups (history, statistics, alarms, and events) of embedded RMON agents for network monitoring and traffic analysis
- Syslog facility for logging system messages about authentication or authorization errors, resource issues, and time-out events
- Layer 2 traceroute to identify the physical path that a packet takes from a source device to a destination device
- Time Domain Reflector (TDR) to diagnose and resolve cabling problems on 10/100 and 10/100/1000 copper Ethernet ports
- SFP module diagnostic management interface to monitor physical or operational status of an SFP module

Default Settings After Initial Switch Configuration

The switch is designed for plug-and-play operation, requiring only that you assign basic IP information to the switch and connect it to the other devices in your network. If you have specific network needs, you can change the interface-specific and system-wide settings.



Note

For information about assigning an IP address by using the browser-based Express Setup program, see the getting started guide. For information about assigning an IP address by using the CLI-based setup program, see the hardware installation guide.

If you do not configure the switch at all, the switch operates with these default settings:

- Default switch IP address, subnet mask, and default gateway is 0.0.0.0. For more information, see [Chapter 3, “Assigning the Switch IP Address and Default Gateway,”](#) and [Chapter 22, “Configuring DHCP Features and IP Source Guard.”](#)
- Default domain name is not configured. For more information, see [Chapter 3, “Assigning the Switch IP Address and Default Gateway.”](#)
- DHCP client is enabled, the DHCP server is enabled (only if the device acting as a DHCP server is configured and is enabled), and the DHCP relay agent is enabled (only if the device is acting as a DHCP relay agent is configured and is enabled). For more information, see [Chapter 3, “Assigning the Switch IP Address and Default Gateway,”](#) and [Chapter 22, “Configuring DHCP Features and IP Source Guard.”](#)
- Switch cluster is disabled. For more information about switch clusters, see [Chapter 5, “Clustering Switches,”](#) and the *Getting Started with Cisco Network Assistant*, available on Cisco.com.

- No passwords are defined. For more information, see [Chapter 6, “Administering the Switch.”](#)
- System name and prompt is *Switch*. For more information, see [Chapter 6, “Administering the Switch.”](#)
- NTP is enabled. For more information, see [Chapter 6, “Administering the Switch.”](#)
- DNS is enabled. For more information, see [Chapter 6, “Administering the Switch.”](#)
- TACACS+ is disabled. For more information, see [Chapter 8, “Configuring Switch-Based Authentication.”](#)
- RADIUS is disabled. For more information, see [Chapter 8, “Configuring Switch-Based Authentication.”](#)
- The standard HTTP server and Secure Socket Layer (SSL) HTTPS server are both enabled. For more information, see [Chapter 8, “Configuring Switch-Based Authentication.”](#)
- IEEE 802.1x is disabled. For more information, see [Chapter 9, “Configuring IEEE 802.1x Port-Based Authentication.”](#)
- Port parameters
 - Interface speed and duplex mode is autonegotiate. For more information, see [Chapter 10, “Configuring Interface Characteristics.”](#)
 - Auto-MDIX is enabled. For more information, see [Chapter 10, “Configuring Interface Characteristics.”](#)
 - Flow control is off. For more information, see [Chapter 10, “Configuring Interface Characteristics.”](#)
- No Smartports macros are defined. For more information, see [Chapter 11, “Configuring Smartports Macros.”](#)
- VLANs
 - Default VLAN is VLAN 1. For more information, see [Chapter 12, “Configuring VLANs.”](#)
 - VLAN trunking setting is dynamic auto (DTP). For more information, see [Chapter 12, “Configuring VLANs.”](#)
 - Trunk encapsulation is negotiate. For more information, see [Chapter 12, “Configuring VLANs.”](#)
 - VTP mode is server. For more information, see [Chapter 13, “Configuring VTP.”](#)
 - VTP version is Version 1. For more information, see [Chapter 13, “Configuring VTP.”](#)
 - Voice VLAN is disabled. For more information, see [Chapter 14, “Configuring Voice VLAN.”](#)
- STP, PVST+ is enabled on VLAN 1. For more information, see [Chapter 15, “Configuring STP.”](#)
- MSTP is disabled. For more information, see [Chapter 16, “Configuring MSTP.”](#)
- Optional spanning-tree features are disabled. For more information, see [Chapter 17, “Configuring Optional Spanning-Tree Features.”](#)
- Flex Links are not configured. For more information, see [Chapter 21, “Configuring Flex Links and the MAC Address-Table Move Update Feature.”](#)
- DHCP snooping is disabled. The DHCP snooping information option is enabled. For more information, see [Chapter 22, “Configuring DHCP Features and IP Source Guard.”](#)
- IGMP snooping is enabled. No IGMP filters are applied. For more information, see [Chapter 18, “Configuring IGMP Snooping and MVR.”](#)

- IGMP throttling setting is deny. For more information, see [Chapter 18, “Configuring IGMP Snooping and MVR.”](#)
- The IGMP snooping querier feature is disabled. For more information, see [Chapter 18, “Configuring IGMP Snooping and MVR.”](#)
- MVR is disabled. For more information, see [Chapter 18, “Configuring IGMP Snooping and MVR.”](#)
- Port-based traffic
 - Broadcast, multicast, and unicast storm control is disabled. For more information, see [Chapter 19, “Configuring Port-Based Traffic Control.”](#)
 - No protected ports are defined. For more information, see [Chapter 19, “Configuring Port-Based Traffic Control.”](#)
 - Unicast and multicast traffic flooding is not blocked. For more information, see [Chapter 19, “Configuring Port-Based Traffic Control.”](#)
 - No secure ports are configured. For more information, see [Chapter 19, “Configuring Port-Based Traffic Control.”](#)
- CDP is enabled. For more information, see [Chapter 20, “Configuring CDP.”](#)
- UDLD is disabled. For more information, see [Chapter 22, “Configuring UDLD.”](#)
- SPAN and RSPAN are disabled. For more information, see [Chapter 23, “Configuring SPAN and RSPAN.”](#)
- RMON is disabled. For more information, see [Chapter 24, “Configuring RMON.”](#)
- Syslog messages are enabled and appear on the console. For more information, see [Chapter 25, “Configuring System Message Logging.”](#)
- SNMP is enabled (Version 1). For more information, see [Chapter 26, “Configuring SNMP.”](#)
- No ACLs are configured. For more information, see [Chapter 34, “Configuring Network Security with ACLs.”](#)
- QoS is disabled. For more information, see [Chapter 28, “Configuring QoS.”](#)
- No EtherChannels are configured. For more information, see [Chapter 31, “Configuring EtherChannels and Link-State Tracking.”](#)

Network Configuration Examples

This section provides network configuration concepts and includes examples of using the switch to create dedicated network segments and interconnecting the segments through Fast Ethernet and Gigabit Ethernet connections.

- [“Design Concepts for Using the Switch” section on page 1-12](#)
- [“Small to Medium-Sized Network Using Catalyst 2960 Switches” section on page 1-16](#)
- [“Long-Distance, High-Bandwidth Transport Configuration” section on page 1-17](#)

Design Concepts for Using the Switch

As your network users compete for network bandwidth, it takes longer to send and receive data. When you configure your network, consider the bandwidth required by your network users and the relative priority of the network applications that they use.

Table 1-1 describes what can cause network performance to degrade and how you can configure your network to increase the bandwidth available to your network users.

Table 1-1 **Increasing Network Performance**

Network Demands	Suggested Design Methods
Too many users on a single network segment and a growing number of users accessing the Internet	<ul style="list-style-type: none"> • Create smaller network segments so that fewer users share the bandwidth, and use VLANs and IP subnets to place the network resources in the same logical network as the users who access those resources most. • Use full-duplex operation between the switch and its connected workstations.
<ul style="list-style-type: none"> • Increased power of new PCs, workstations, and servers • High bandwidth demand from networked applications (such as e-mail with large attached files) and from bandwidth-intensive applications (such as multimedia) 	<ul style="list-style-type: none"> • Connect global resources—such as servers and routers to which the network users require equal access—directly to the high-speed switch ports so that they have their own high-speed segment. • Use the EtherChannel feature between the switch and its connected servers and routers.

Bandwidth alone is not the only consideration when designing your network. As your network traffic profiles evolve, consider providing network services that can support applications for voice and data integration, multimedia integration, application prioritization, and security. Table 1-2 describes some network demands and how you can meet them.

Table 1-2 **Providing Network Services**

Network Demands	Suggested Design Methods
Efficient bandwidth usage for multimedia applications and guaranteed bandwidth for critical applications	<ul style="list-style-type: none"> • Use IGMP snooping to efficiently forward multimedia and multicast traffic. • Use other QoS mechanisms such as packet classification, marking, scheduling, and congestion avoidance to classify traffic with the appropriate priority level, thereby providing maximum flexibility and support for mission-critical, unicast, and multicast and multimedia applications. • Use MVR to continuously send multicast streams in a multicast VLAN but to isolate the streams from subscriber VLANs for bandwidth and security reasons.
High demand on network redundancy and availability to provide <i>always on</i> mission-critical applications	<ul style="list-style-type: none"> • Use VLAN trunks and BackboneFast for traffic-load balancing on the uplink ports so that the uplink port with a lower relative port cost is selected to carry the VLAN traffic.

Table 1-2 Providing Network Services (continued)

Network Demands	Suggested Design Methods
An evolving demand for IP telephony	<ul style="list-style-type: none"> Use QoS to prioritize applications such as IP telephony during congestion and to help control both delay and jitter within the network. Use switches that support at least two queues per port to prioritize voice and data traffic as either high- or low-priority, based on IEEE 802.1p/Q. The switch supports at least four queues per port. Use voice VLAN IDs (VVIDs) to provide separate VLANs for voice traffic.
A growing demand for using existing infrastructure to transport data and voice from a home or office to the Internet or an intranet at higher speeds	<p>Use the Catalyst Long-Reach Ethernet (LRE) switches to provide up to 15 Mb of IP connectivity over existing infrastructure, such as existing telephone lines.</p> <p>Note LRE is the technology used in the Catalyst 2900 LRE XL and Catalyst 2950 LRE switches. See the documentation sets specific to these switches for LRE information.</p>

You can use the switches to create the following:

- Cost-effective Gigabit-to-the-desktop for high-performance workgroups ([Figure 1-1](#))—For high-speed access to network resources, you can use the Cisco Catalyst 2960 switches in the access layer to provide Gigabit Ethernet to the desktop. To prevent congestion, use QoS DSCP marking priorities on these switches. For high-speed IP forwarding at the distribution layer, connect the switches in the access layer to a Gigabit multilayer switch with routing capability, such as a Catalyst 3750 switch, or to a router.

The first illustration is of an isolated high-performance workgroup, where the Catalyst 2960 switches are connected to Catalyst 3750 switches in the distribution layer. The second illustration is of a high-performance workgroup in a branch office, where the Catalyst 2960 switches are connected to a router in the distribution layer.

Each switch in this configuration provides users with a dedicated 1-Gb/s connection to network resources. Using SFP modules also provides flexibility in media and distance options through fiber-optic connections.

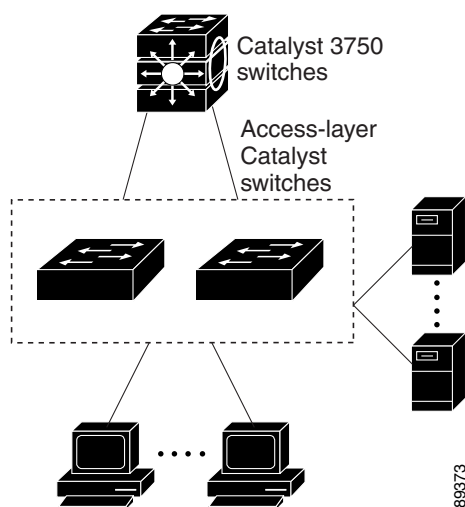
Figure 1-1 High-Performance Workgroup (Gigabit-to-the-Desktop)

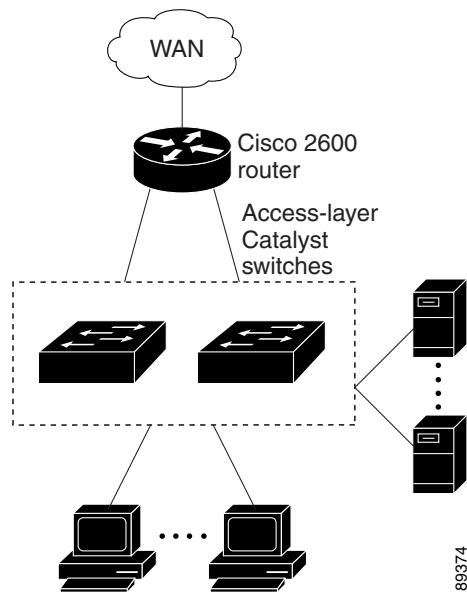

- Server aggregation ([Figure 1-2](#))—You can use the switches to interconnect groups of servers, centralizing physical security and administration of your network. For high-speed IP forwarding at the distribution layer, connect the switches in the access layer to multilayer switches with routing capability. The Gigabit interconnections minimize latency in the data flow.

QoS and policing on the switches provide preferential treatment for certain data streams. They segment traffic streams into different paths for processing. Security features on the switch ensure rapid handling of packets.

Fault tolerance from the server racks to the core is achieved through dual homing of servers connected to switches, which have redundant Gigabit EtherChannels.

Using dual SFP module uplinks from the switches provides redundant uplinks to the network core. Using SFP modules provides flexibility in media and distance options through fiber-optic connections.

Figure 1-2 Server Aggregation

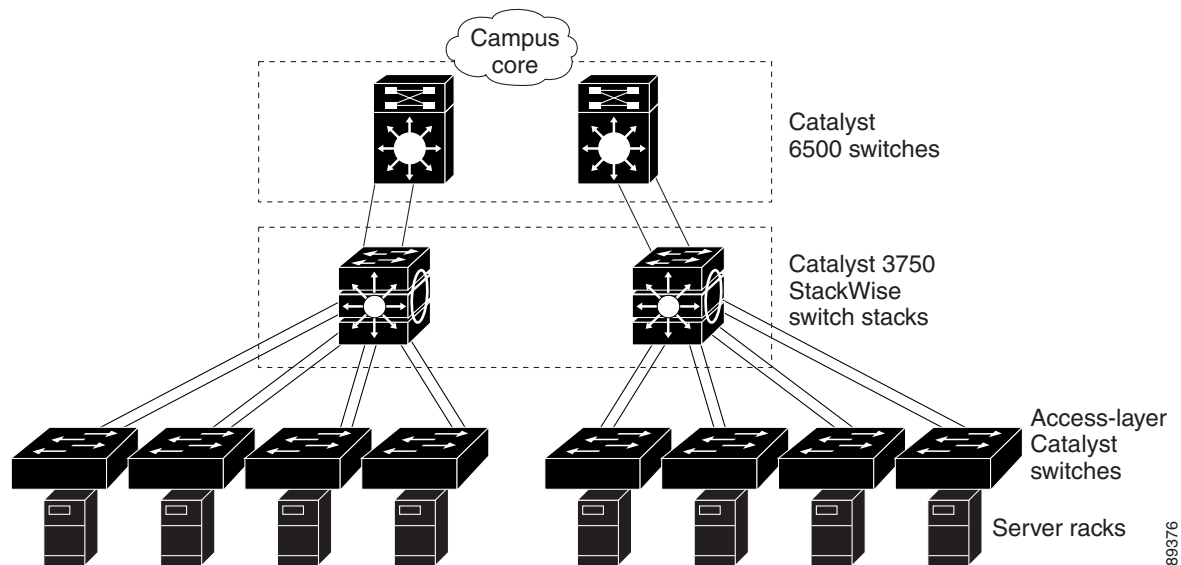

Small to Medium-Sized Network Using Catalyst 2960 Switches

Figure 1-3 shows a configuration for a network of up to 500 employees. This network uses Catalyst 2960 switches with high-speed connections to two routers. This ensures connectivity to the Internet, WAN, and mission-critical network resources in case one of the routers fails. The switches are using EtherChannel for load sharing.

The switches are connected to workstations and local servers. The server farm includes a call-processing server running Cisco CallManager software. Cisco CallManager controls call processing, routing, and Cisco IP Phone features and configuration. The switches are interconnected through Gigabit interfaces.

This network uses VLANs to logically segment the network into well-defined broadcast groups and for security management. Data and multimedia traffic are configured on the same VLAN. Voice traffic from the Cisco IP Phones are configured on separate VVIDs. If data, multimedia, and voice traffic are assigned to the same VLAN, only one VLAN can be configured per wiring closet.

When an end station in one VLAN needs to communicate with an end station in another VLAN, a router routes the traffic to the destination VLAN. In this network, the routers are providing inter-VLAN routing. VLAN access control lists (VLAN maps) on the switch provide intra-VLAN security and prevent unauthorized users from accessing critical areas of the network.

In addition to inter-VLAN routing, the routers provide QoS mechanisms such as DSCP priorities to prioritize the different types of network traffic and to deliver high-priority traffic. If congestion occurs, QoS drops low-priority traffic to allow delivery of high-priority traffic.

Cisco CallManager controls call processing, routing, and Cisco IP Phone features and configuration. Users with workstations running Cisco SoftPhone software can place, receive, and control calls from their PCs. Using Cisco IP Phones, Cisco CallManager software, and Cisco SoftPhone software integrates telephony and IP networks, and the IP network supports both voice and data.

The routers also provide firewall services, Network Address Translation (NAT) services, voice-over-IP (VoIP) gateway services, and WAN and Internet access.

Figure 1-3 Catalyst 2960 Switches in a Collapsed Backbone Configuration

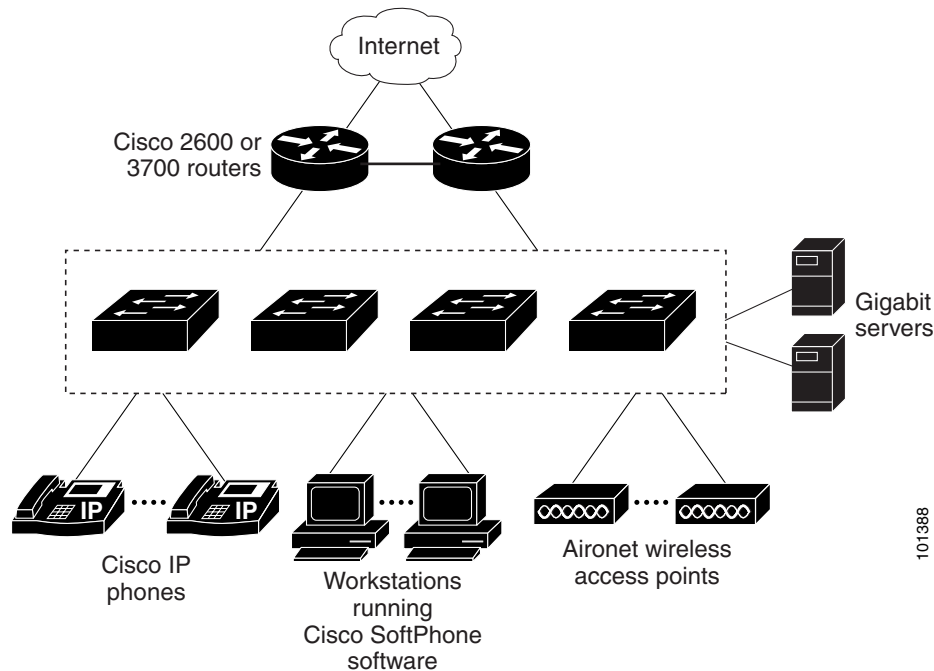

Long-Distance, High-Bandwidth Transport Configuration

Figure 1-4 shows a configuration for sending 8 Gigabits of data over a single fiber-optic cable. The Catalyst 2960 switches have coarse wavelength-division multiplexing (CWDM) fiber-optic SFP modules installed. Depending on the CWDM SFP module, data is sent at wavelengths from 1470 to 1610 nm. The higher the wavelength, the farther the transmission can travel. A common wavelength used for long-distance transmissions is 1550 nm.

The CWDM SFP modules connect to CWDM optical add/drop multiplexer (OADM) modules over distances of up to 393,701 feet (74.5 miles or 120 km). The CWDM OADM modules combine (or *multiplex*) the different CWDM wavelengths, allowing them to travel simultaneously on the same fiber-optic cable. The CWDM OADM modules on the receiving end separate (or *demultiplex*) the different wavelengths.

For more information about the CWDM SFP modules and CWDM OADM modules, see the *Cisco CWDM GBIC and CWDM SFP Installation Note*.

Figure 1-4 Long-Distance, High-Bandwidth Transport Configuration

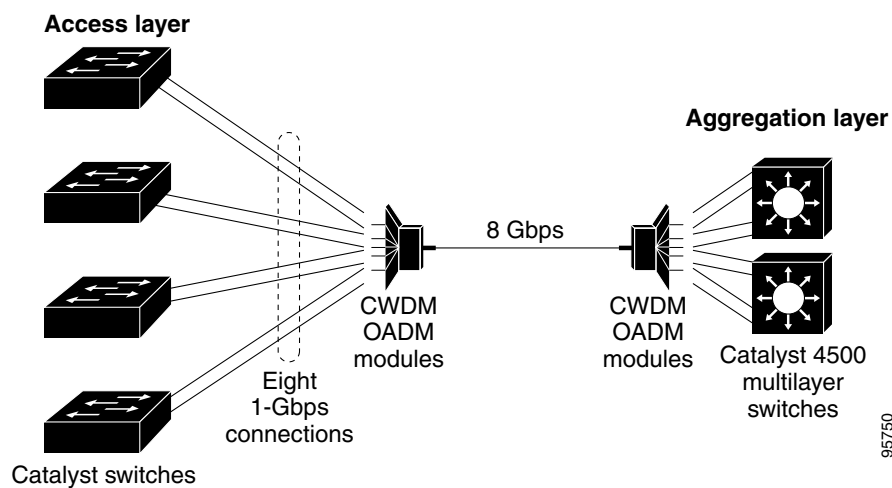

Where to Go Next

Before configuring the switch, review these sections for startup information:

- [Chapter 2, “Using the Command-Line Interface”](#)
- [Chapter 3, “Assigning the Switch IP Address and Default Gateway”](#)



CHAPTER 2

Using the Command-Line Interface

This chapter describes the Cisco IOS command-line interface (CLI) and how to use it to configure your Catalyst 2960 switch. It contains these sections:

- [Understanding Command Modes, page 2-1](#)
- [Understanding the Help System, page 2-3](#)
- [Understanding Abbreviated Commands, page 2-4](#)
- [Understanding no and default Forms of Commands, page 2-4](#)
- [Understanding CLI Error Messages, page 2-5](#)
- [Using Configuration Logging, page 2-5](#)
- [Using Command History, page 2-6](#)
- [Using Editing Features, page 2-7](#)
- [Searching and Filtering Output of show and more Commands, page 2-10](#)
- [Accessing the CLI, page 2-10](#)

Understanding Command Modes

The Cisco IOS user interface is divided into many different modes. The commands available to you depend on which mode you are currently in. Enter a question mark (?) at the system prompt to obtain a list of commands available for each command mode.

When you start a session on the switch, you begin in user mode, often called user EXEC mode. Only a limited subset of the commands are available in user EXEC mode. For example, most of the user EXEC commands are one-time commands, such as **show** commands, which show the current configuration status, and **clear** commands, which clear counters or interfaces. The user EXEC commands are not saved when the switch reboots.

To have access to all commands, you must enter privileged EXEC mode. Normally, you must enter a password to enter privileged EXEC mode. From this mode, you can enter any privileged EXEC command or enter global configuration mode.

Using the configuration modes (global, interface, and line), you can make changes to the running configuration. If you save the configuration, these commands are stored and used when the switch reboots. To access the various configuration modes, you must start at global configuration mode. From global configuration mode, you can enter interface configuration mode and line configuration mode.

Table 2-1 describes the main command modes, how to access each one, the prompt you see in that mode, and how to exit the mode. The examples in the table use the hostname *Switch*.

Table 2-1 Command Mode Summary

Mode	Access Method	Prompt	Exit Method	About This Mode
User EXEC	Begin a session with your switch.	Switch>	Enter logout or quit .	Use this mode to <ul style="list-style-type: none"> • Change terminal settings. • Perform basic tests. • Display system information.
Privileged EXEC	While in user EXEC mode, enter the enable command.	Switch#	Enter disable to exit.	Use this mode to verify commands that you have entered. Use a password to protect access to this mode.
Global configuration	While in privileged EXEC mode, enter the configure command.	Switch(config)#	To exit to privileged EXEC mode, enter exit or end , or press Ctrl-Z .	Use this mode to configure parameters that apply to the entire switch.
Config-vlan	While in global configuration mode, enter the vlan vlan-id command.	Switch(config-vlan)#	To exit to global configuration mode, enter the exit command. To return to privileged EXEC mode, press Ctrl-Z or enter end .	Use this mode to configure VLAN parameters. When VTP mode is transparent, you can create extended-range VLANs (VLAN IDs greater than 1005) and save configurations in the switch startup configuration file.
VLAN configuration	While in privileged EXEC mode, enter the vlan database command.	Switch(vlan)#	To exit to privileged EXEC mode, enter exit .	Use this mode to configure VLAN parameters for VLANs 1 to 1005 in the VLAN database.

Table 2-1 Command Mode Summary (continued)

Mode	Access Method	Prompt	Exit Method	About This Mode
Interface configuration	While in global configuration mode, enter the interface command (with a specific interface).	Switch(config-if)#	To exit to global configuration mode, enter exit . To return to privileged EXEC mode, press Ctrl-Z or enter end .	Use this mode to configure parameters for the Ethernet ports. For information about defining interfaces, see the “Using Interface Configuration Mode” section on page 10-4. To configure multiple interfaces with the same parameters, see the “Configuring a Range of Interfaces” section on page 10-6.
Line configuration	While in global configuration mode, specify a line with the line vty or line console command.	Switch(config-line)#	To exit to global configuration mode, enter exit . To return to privileged EXEC mode, press Ctrl-Z or enter end .	Use this mode to configure parameters for the terminal line.

For more detailed information on the command modes, see the command reference guide for this release.

Understanding the Help System

You can enter a question mark (?) at the system prompt to display a list of commands available for each command mode. You can also obtain a list of associated keywords and arguments for any command, as shown in [Table 2-2](#).

Table 2-2 Help Summary

Command	Purpose
help	Obtain a brief description of the help system in any command mode.
<i>abbreviated-command-entry?</i>	Obtain a list of commands that begin with a particular character string. For example: <pre>Switch# di? dir disable disconnect</pre>
<i>abbreviated-command-entry<Tab></i>	Complete a partial command name. For example: <pre>Switch# sh conf<tab> Switch# show configuration</pre>

Table 2-2 Help Summary (continued)

Command	Purpose
<code>?</code>	List all commands available for a particular command mode. For example: Switch> <code>?</code>
<code>command ?</code>	List the associated keywords for a command. For example: Switch> <code>show ?</code>
<code>command keyword ?</code>	List the associated arguments for a keyword. For example: Switch(config)# <code>cdp holdtime ?</code> <10-255> Length of time (in sec) that receiver must keep this packet

Understanding Abbreviated Commands

You need to enter only enough characters for the switch to recognize the command as unique.

This example shows how to enter the **show configuration** privileged EXEC command in an abbreviated form:

```
Switch# show conf
```

Understanding no and default Forms of Commands

Almost every configuration command also has a **no** form. In general, use the **no** form to disable a feature or function or reverse the action of a command. For example, the **no shutdown** interface configuration command reverses the shutdown of an interface. Use the command without the keyword **no** to re-enable a disabled feature or to enable a feature that is disabled by default.

Configuration commands can also have a **default** form. The **default** form of a command returns the command setting to its default. Most commands are disabled by default, so the **default** form is the same as the **no** form. However, some commands are enabled by default and have variables set to certain default values. In these cases, the **default** command enables the command and sets variables to their default values.

Understanding CLI Error Messages

Table 2-3 lists some error messages that you might encounter while using the CLI to configure your switch.

Table 2-3 Common CLI Error Messages

Error Message	Meaning	How to Get Help
% Ambiguous command: "show con"	You did not enter enough characters for your switch to recognize the command.	Re-enter the command followed by a question mark (?) with a space between the command and the question mark. The possible keywords that you can enter with the command appear.
% Incomplete command.	You did not enter all the keywords or values required by this command.	Re-enter the command followed by a question mark (?) with a space between the command and the question mark. The possible keywords that you can enter with the command appear.
% Invalid input detected at '^' marker.	You entered the command incorrectly. The caret (^) marks the point of the error.	Enter a question mark (?) to display all the commands that are available in this command mode. The possible keywords that you can enter with the command appear.

Using Configuration Logging

Beginning with Cisco IOS Release 12.2(25)SED, you can log and view changes to the switch configuration. You can use the Configuration Change Logging and Notification feature to track changes on a per-session and per-user basis. The logger tracks each configuration command that is applied, the user who entered the command, the time that the command was entered, and the parser return code for the command. This feature includes a mechanism for asynchronous notification to registered applications whenever the configuration changes. You can choose to have the notifications sent to the syslog.

For more information, see the *Configuration Change Notification and Logging* feature module at this URL:

http://www.cisco.com/en/US/products/sw/iosswrel/ps5207/products_feature_guide09186a00801d1e81.html



Note

Only CLI or HTTP changes are logged.

Using Command History

The software provides a history or record of commands that you have entered. The command history feature is particularly useful for recalling long or complex commands or entries, including access lists. You can customize this feature to suit your needs as described in these sections:

- [Changing the Command History Buffer Size, page 2-6](#) (optional)
- [Recalling Commands, page 2-6](#) (optional)
- [Disabling the Command History Feature, page 2-7](#) (optional)

Changing the Command History Buffer Size

By default, the switch records ten command lines in its history buffer. You can alter this number for a current terminal session or for all sessions on a particular line. These procedures are optional.

Beginning in privileged EXEC mode, enter this command to change the number of command lines that the switch records during the current terminal session:

```
Switch# terminal history [size number-of-lines]
```

The range is from 0 to 256.

Beginning in line configuration mode, enter this command to configure the number of command lines the switch records for all sessions on a particular line:

```
Switch(config-line)# history [size number-of-lines]
```

The range is from 0 to 256.

Recalling Commands

To recall commands from the history buffer, perform one of the actions listed in [Table 2-4](#). These actions are optional.

Table 2-4 *Recalling Commands*

Action ¹	Result
Press Ctrl-P or the up arrow key.	Recall commands in the history buffer, beginning with the most recent command. Repeat the key sequence to recall successively older commands.
Press Ctrl-N or the down arrow key.	Return to more recent commands in the history buffer after recalling commands with Ctrl-P or the up arrow key. Repeat the key sequence to recall successively more recent commands.
show history	While in privileged EXEC mode, list the last several commands that you just entered. The number of commands that appear is controlled by the setting of the terminal history global configuration command and the history line configuration command.

1. The arrow keys function only on ANSI-compatible terminals such as VT100s.

Disabling the Command History Feature

The command history feature is automatically enabled. You can disable it for the current terminal session or for the command line. These procedures are optional.

To disable the feature during the current terminal session, enter the **terminal no history** privileged EXEC command.

To disable command history for the line, enter the **no history** line configuration command.

Using Editing Features

This section describes the editing features that can help you manipulate the command line. It contains these sections:

- [Enabling and Disabling Editing Features, page 2-7](#) (optional)
- [Editing Commands through Keystrokes, page 2-7](#) (optional)
- [Editing Command Lines that Wrap, page 2-9](#) (optional)

Enabling and Disabling Editing Features

Although enhanced editing mode is automatically enabled, you can disable it, re-enable it, or configure a specific line to have enhanced editing. These procedures are optional.

To globally disable enhanced editing mode, enter this command in line configuration mode:

```
Switch (config-line)# no editing
```

To re-enable the enhanced editing mode for the current terminal session, enter this command in privileged EXEC mode:

```
Switch# terminal editing
```

To reconfigure a specific line to have enhanced editing mode, enter this command in line configuration mode:

```
Switch(config-line)# editing
```

Editing Commands through Keystrokes

[Table 2-5](#) shows the keystrokes that you need to edit command lines. These keystrokes are optional.

Table 2-5 *Editing Commands through Keystrokes*

Capability	Keystroke ¹	Purpose
Move around the command line to make changes or corrections.	Press Ctrl-B , or press the left arrow key.	Move the cursor back one character.

Table 2-5 Editing Commands through Keystrokes (continued)

Capability	Keystroke ¹	Purpose
	Press Ctrl-F , or press the right arrow key.	Move the cursor forward one character.
	Press Ctrl-A .	Move the cursor to the beginning of the command line.
	Press Ctrl-E .	Move the cursor to the end of the command line.
	Press Esc B .	Move the cursor back one word.
	Press Esc F .	Move the cursor forward one word.
	Press Ctrl-T .	Transpose the character to the left of the cursor with the character located at the cursor.
Recall commands from the buffer and paste them in the command line. The switch provides a buffer with the last ten items that you deleted.	Press Ctrl-Y .	Recall the most recent entry in the buffer.
	Press Esc Y .	Recall the next buffer entry. The buffer contains only the last 10 items that you have deleted or cut. If you press Esc Y more than ten times, you cycle to the first buffer entry.
Delete entries if you make a mistake or change your mind.	Press the Delete or Backspace key.	Erase the character to the left of the cursor.
	Press Ctrl-D .	Delete the character at the cursor.
	Press Ctrl-K .	Delete all characters from the cursor to the end of the command line.
	Press Ctrl-U or Ctrl-X .	Delete all characters from the cursor to the beginning of the command line.
	Press Ctrl-W .	Delete the word to the left of the cursor.
	Press Esc D .	Delete from the cursor to the end of the word.
Capitalize or lowercase words or capitalize a set of letters.	Press Esc C .	Capitalize at the cursor.
	Press Esc L .	Change the word at the cursor to lowercase.
	Press Esc U .	Capitalize letters from the cursor to the end of the word.
Designate a particular keystroke as an executable command, perhaps as a shortcut.	Press Ctrl-V or Esc Q .	

Table 2-5 *Editing Commands through Keystrokes (continued)*

Capability	Keystroke ¹	Purpose
Scroll down a line or screen on displays that are longer than the terminal screen can display. Note The More prompt is used for any output that has more lines than can be displayed on the terminal screen, including show command output. You can use the Return and Space bar keystrokes whenever you see the More prompt.	Press the Return key.	Scroll down one line.
	Press the Space bar.	Scroll down one screen.
Redisplay the current command line if the switch suddenly sends a message to your screen.	Press Ctrl-L or Ctrl-R .	Redisplay the current command line.

1. The arrow keys function only on ANSI-compatible terminals such as VT100s.

Editing Command Lines that Wrap

You can use a wraparound feature for commands that extend beyond a single line on the screen. When the cursor reaches the right margin, the command line shifts ten spaces to the left. You cannot see the first ten characters of the line, but you can scroll back and check the syntax at the beginning of the command. The keystroke actions are optional.

To scroll back to the beginning of the command entry, press **Ctrl-B** or the left arrow key repeatedly. You can also press **Ctrl-A** to immediately move to the beginning of the line.

The arrow keys function only on ANSI-compatible terminals such as VT100s.

In this example, the **access-list** global configuration command entry extends beyond one line. When the cursor first reaches the end of the line, the line is shifted ten spaces to the left and redisplayed. The dollar sign (\$) shows that the line has been scrolled to the left. Each time the cursor reaches the end of the line, the line is again shifted ten spaces to the left.

```
Switch(config)# access-list 101 permit tcp 131.108.2.5 255.255.255.0 131.108.1
Switch(config)# $ 101 permit tcp 131.108.2.5 255.255.255.0 131.108.1.20 255.25
Switch(config)# $t tcp 131.108.2.5 255.255.255.0 131.108.1.20 255.255.255.0 eq
Switch(config)# $108.2.5 255.255.255.0 131.108.1.20 255.255.255.0 eq 45
```

After you complete the entry, press **Ctrl-A** to check the complete syntax before pressing the **Return** key to execute the command. The dollar sign (\$) appears at the end of the line to show that the line has been scrolled to the right:

```
Switch(config)# access-list 101 permit tcp 131.108.2.5 255.255.255.0 131.108.1$
```

The software assumes you have a terminal screen that is 80 columns wide. If you have a width other than that, use the **terminal width** privileged EXEC command to set the width of your terminal.

Use line wrapping with the command history feature to recall and modify previous complex command entries. For information about recalling previous command entries, see the [“Editing Commands through Keystrokes”](#) section on page 2-7.

Searching and Filtering Output of show and more Commands

You can search and filter the output for **show** and **more** commands. This is useful when you need to sort through large amounts of output or if you want to exclude output that you do not need to see. Using these commands is optional.

To use this functionality, enter a **show** or **more** command followed by the *pipe* character (`|`), one of the keywords **begin**, **include**, or **exclude**, and an expression that you want to search for or filter out:

```
command | {begin | include | exclude} regular-expression
```

Expressions are case sensitive. For example, if you enter `| exclude output`, the lines that contain *output* are not displayed, but the lines that contain *Output* appear.

This example shows how to include in the output display only lines where the expression *protocol* appears:

```
Switch# show interfaces | include protocol
Vlan1 is up, line protocol is up
Vlan10 is up, line protocol is down
GigabitEthernet0/1 is up, line protocol is down
GigabitEthernet0/2 is up, line protocol is up
```

Accessing the CLI

You can access the CLI through a console connection, through Telnet, or by using the browser.

Accessing the CLI through a Console Connection or through Telnet

Before you can access the CLI, you must connect a terminal or PC to the switch console port and power on the switch, as described in the getting started guide that shipped with your switch. Then, to understand the boot process and the options available for assigning IP information, see [Chapter 3, “Assigning the Switch IP Address and Default Gateway.”](#)

If your switch is already configured, you can access the CLI through a local console connection or through a remote Telnet session, but your switch must first be configured for this type of access. For more information, see the [“Setting a Telnet Password for a Terminal Line” section on page 8-6.](#)

You can use one of these methods to establish a connection with the switch:

- Connect the switch console port to a management station or dial-up modem. For information about connecting to the console port, see the switch getting started guide or hardware installation guide.
- Use any Telnet TCP/IP or encrypted Secure Shell (SSH) package from a remote management station. The switch must have network connectivity with the Telnet or SSH client, and the switch must have an enable secret password configured.

For information about configuring the switch for Telnet access, see the [“Setting a Telnet Password for a Terminal Line” section on page 8-6.](#) The switch supports up to 16 simultaneous Telnet sessions. Changes made by one Telnet user are reflected in all other Telnet sessions.

For information about configuring the switch for SSH, see the [“Configuring the Switch for Secure Shell” section on page 8-33.](#) The switch supports up to five simultaneous secure SSH sessions.

After you connect through the console port, through a Telnet session or through an SSH session, the user EXEC prompt appears on the management station.



CHAPTER 3

Assigning the Switch IP Address and Default Gateway

This chapter describes how to create the initial switch configuration (for example, assigning the IP address and default gateway information) for the Catalyst 2960 switch by using a variety of automatic and manual methods. It also describes how to modify the switch startup configuration.



Note

For complete syntax and usage information for the commands used in this chapter, see the command reference for this release and the *Cisco IOS IP Command Reference, Volume 1 of 3: Addressing and Services* from the Cisco.com page under **Documentation > Cisco IOS Software > 12.2 Mainline > Command References**.

This chapter consists of these sections:

- [Understanding the Boot Process, page 3-1](#)
- [Assigning Switch Information, page 3-2](#)
- [Checking and Saving the Running Configuration, page 3-10](#)
- [Modifying the Startup Configuration, page 3-11](#)
- [Scheduling a Reload of the Software Image, page 3-16](#)

Understanding the Boot Process

To start your switch, you need to follow the procedures in the *Getting Started Guide* or the hardware installation guide for installing and powering on the switch and setting up the initial switch configuration (IP address, subnet mask, default gateway, secret and Telnet passwords, and so forth).

The normal boot process involves the operation of the boot loader software, which performs these activities:

- Performs low-level CPU initialization. It initializes the CPU registers, which control where physical memory is mapped, its quantity, its speed, and so forth.
- Performs power-on self-test (POST) for the CPU subsystem. It tests the CPU DRAM and the portion of the flash device that makes up the flash file system.
- Initializes the flash file system on the system board.
- Loads a default operating system software image into memory and boots up the switch.

The boot loader provides access to the flash file system before the operating system is loaded. Normally, the boot loader is used only to load, uncompress, and launch the operating system. After the boot loader gives the operating system control of the CPU, the boot loader is not active until the next system reset or power-on.

The boot loader also provides trap-door access into the system if the operating system has problems serious enough that it cannot be used. The trap-door mechanism provides enough access to the system so that if it is necessary, you can format the flash file system, reinstall the operating system software image by using the Xmodem Protocol, recover from a lost or forgotten password, and finally restart the operating system. For more information, see the [“Recovering from a Software Failure”](#) section on page 32-2 and the [“Recovering from a Lost or Forgotten Password”](#) section on page 32-3.

**Note**

You can disable password recovery. For more information, see the [“Disabling Password Recovery”](#) section on page 8-5.

Before you can assign switch information, make sure you have connected a PC or terminal to the console port, and configured the PC or terminal-emulation software baud rate and character format to match these of the switch console port:

- Baud rate default is 9600.
- Data bits default is 8.

**Note**

If the data bits option is set to 8, set the parity option to none.

- Stop bits default is 1.
- Parity settings default is none.

Assigning Switch Information

You can assign IP information through the switch setup program, through a DHCP server, or manually.

Use the switch setup program if you want to be prompted for specific IP information. With this program, you can also configure a hostname and an enable secret password. It gives you the option of assigning a Telnet password (to provide security during remote management) and configuring your switch as a command or member switch of a cluster or as a standalone switch. For more information about the setup program, see the hardware installation guide.

Use a DHCP server for centralized control and automatic assignment of IP information after the server is configured.

**Note**

If you are using DHCP, do not respond to any of the questions in the setup program until the switch receives the dynamically assigned IP address and reads the configuration file.

If you are an experienced user familiar with the switch configuration steps, manually configure the switch. Otherwise, use the setup program described previously.

These sections contain this configuration information:

- [Default Switch Information, page 3-3](#)
- [Understanding DHCP-Based Autoconfiguration, page 3-3](#)
- [Manually Assigning IP Information, page 3-10](#)

Default Switch Information

Table 3-1 shows the default switch information.

Table 3-1 **Default Switch Information**

Feature	Default Setting
IP address and subnet mask	No IP address or subnet mask are defined.
Default gateway	No default gateway is defined.
Enable secret password	No password is defined.
Hostname	The factory-assigned default hostname is <i>Switch</i> .
Telnet password	No password is defined.
Cluster command switch functionality	Disabled.
Cluster name	No cluster name is defined.

Understanding DHCP-Based Autoconfiguration

DHCP provides configuration information to Internet hosts and internetworking devices. This protocol consists of two components: one for delivering configuration parameters from a DHCP server to a device and a mechanism for allocating network addresses to devices. DHCP is built on a client-server model, in which designated DHCP servers allocate network addresses and deliver configuration parameters to dynamically configured devices. The switch can act as both a DHCP client and a DHCP server.

During DHCP-based autoconfiguration, your switch (DHCP client) is automatically configured at startup with IP address information and a configuration file.

With DHCP-based autoconfiguration, no DHCP client-side configuration is needed on your switch. However, you need to configure the DHCP server for various lease options associated with IP addresses. If you are using DHCP to relay the configuration file location on the network, you might also need to configure a Trivial File Transfer Protocol (TFTP) server and a Domain Name System (DNS) server.

The DHCP server for your switch can be on the same LAN or on a different LAN than the switch. If the DHCP server is running on a different LAN, you should configure a DHCP relay device between your switch and the DHCP server. A relay device forwards broadcast traffic between two directly connected LANs. A router does not forward broadcast packets, but it forwards packets based on the destination IP address in the received packet.

DHCP-based autoconfiguration replaces the BOOTP client functionality on your switch.

DHCP Client Request Process

When you boot up your switch, the DHCP client is invoked and requests configuration information from a DHCP server when the configuration file is not present on the switch. If the configuration file is present and the configuration includes the **ip address dhcp** interface configuration command on specific routed interfaces, the DHCP client is invoked and requests the IP address information for those interfaces.

Figure 3-1 shows the sequence of messages that are exchanged between the DHCP client and the DHCP server.

Figure 3-1 DHCP Client and Server Message Exchange

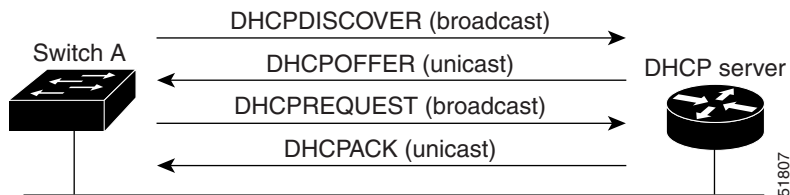

The client, Switch A, broadcasts a DHCPDISCOVER message to locate a DHCP server. The DHCP server offers configuration parameters (such as an IP address, subnet mask, gateway IP address, DNS IP address, a lease for the IP address, and so forth) to the client in a DHCPOFFER unicast message.

In a DHCPREQUEST broadcast message, the client returns a formal request for the offered configuration information to the DHCP server. The formal request is broadcast so that all other DHCP servers that received the DHCPDISCOVER broadcast message from the client can reclaim the IP addresses that they offered to the client.

The DHCP server confirms that the IP address has been allocated to the client by returning a DHCPACK unicast message to the client. With this message, the client and server are bound, and the client uses configuration information received from the server. The amount of information the switch receives depends on how you configure the DHCP server. For more information, see the “[Configuring the TFTP Server](#)” section on page 3-6.

If the configuration parameters sent to the client in the DHCPOFFER unicast message are invalid (a configuration error exists), the client returns a DHCPDECLINE broadcast message to the DHCP server.

The DHCP server sends the client a DHCPNAK denial broadcast message, which means that the offered configuration parameters have not been assigned, that an error has occurred during the negotiation of the parameters, or that the client has been slow in responding to the DHCPOFFER message (the DHCP server assigned the parameters to another client).

A DHCP client might receive offers from multiple DHCP or BOOTP servers and can accept any of the offers; however, the client usually accepts the first offer it receives. The offer from the DHCP server is not a guarantee that the IP address is allocated to the client; however, the server usually reserves the address until the client has had a chance to formally request the address. If the switch accepts replies from a BOOTP server and configures itself, the switch broadcasts, instead of unicasts, TFTP requests to obtain the switch configuration file.

Configuring DHCP-Based Autoconfiguration

These sections contain this configuration information:

- [DHCP Server Configuration Guidelines, page 3-5](#)
- [Configuring the TFTP Server, page 3-6](#)
- [Configuring the DNS, page 3-6](#)
- [Configuring the Relay Device, page 3-6](#)
- [Obtaining Configuration Files, page 3-7](#)
- [Example Configuration, page 3-8](#)

If your DHCP server is a Cisco device, for additional information about configuring DHCP, see the “Configuring DHCP” section of the “IP Addressing and Services” section of the *Cisco IOS IP Configuration Guide* from the Cisco.com page under **Documentation > Cisco IOS Software > 12.2 Mainline > Configuration Guides**.

DHCP Server Configuration Guidelines

Follow these guidelines if you are configuring a device as a DHCP server:

You should configure the DHCP server with reserved leases that are bound to each switch by the switch hardware address.

If you want the switch to receive IP address information, you must configure the DHCP server with these lease options:

- IP address of the client (required)
- Subnet mask of the client (required)
- DNS server IP address (optional)
- Router IP address (default gateway address to be used by the switch) (required)

If you want the switch to receive the configuration file from a TFTP server, you must configure the DHCP server with these lease options:

- TFTP server name (required)
- Boot filename (the name of the configuration file that the client needs) (recommended)
- Hostname (optional)

Depending on the settings of the DHCP server, the switch can receive IP address information, the configuration file, or both.

If you do not configure the DHCP server with the lease options described previously, it replies to client requests with only those parameters that are configured. If the IP address and the subnet mask are not in the reply, the switch is not configured. If the router IP address or the TFTP server name are not found, the switch might send broadcast, instead of unicast, TFTP requests. Unavailability of other lease options does not affect autoconfiguration.

Configuring the TFTP Server

Based on the DHCP server configuration, the switch attempts to download one or more configuration files from the TFTP server. If you configured the DHCP server to respond to the switch with all the options required for IP connectivity to the TFTP server, and if you configured the DHCP server with a TFTP server name, address, and configuration filename, the switch attempts to download the specified configuration file from the specified TFTP server.

If you did not specify the configuration filename, the TFTP server, or if the configuration file could not be downloaded, the switch attempts to download a configuration file by using various combinations of filenames and TFTP server addresses. The files include the specified configuration filename (if any) and these files: `network-config`, `cisconet.cfg`, `hostname.config`, or `hostname.cfg`, where *hostname* is the switch's current hostname. The TFTP server addresses used include the specified TFTP server address (if any) and the broadcast address (255.255.255.255).

For the switch to successfully download a configuration file, the TFTP server must contain one or more configuration files in its base directory. The files can include these files:

- The configuration file named in the DHCP reply (the actual switch configuration file).
- The `network-config` or the `cisconet.cfg` file (known as the default configuration files).
- The `router-config` or the `ciscortr.cfg` file (These files contain commands common to all switches. Normally, if the DHCP and TFTP servers are properly configured, these files are not accessed.)

If you specify the TFTP server name in the DHCP server-lease database, you must also configure the TFTP server name-to-IP-address mapping in the DNS-server database.

If the TFTP server to be used is on a different LAN from the switch, or if it is to be accessed by the switch through the broadcast address (which occurs if the DHCP server response does not contain all the required information described previously), a relay must be configured to forward the TFTP packets to the TFTP server. For more information, see the [“Configuring the Relay Device” section on page 3-6](#). The preferred solution is to configure the DHCP server with all the required information.

Configuring the DNS

The DHCP server uses the DNS server to resolve the TFTP server name to an IP address. You must configure the TFTP server name-to-IP address map on the DNS server. The TFTP server contains the configuration files for the switch.

You can configure the IP addresses of the DNS servers in the lease database of the DHCP server from where the DHCP replies will retrieve them. You can enter up to two DNS server IP addresses in the lease database.

The DNS server can be on the same or on a different LAN as the switch. If it is on a different LAN, the switch must be able to access it through a router.

Configuring the Relay Device

You must configure a relay device, also referred to as a *relay agent*, when a switch sends broadcast packets that require a response from a host on a different LAN. Examples of broadcast packets that the switch might send are DHCP, DNS, and in some cases, TFTP packets. You must configure this relay device to forward received broadcast packets on an interface to the destination host.

If the relay device is a Cisco router, enable IP routing (**ip routing** global configuration command), and configure helper addresses by using the **ip helper-address** interface configuration command.

For example, in [Figure 3-2](#), configure the router interfaces as follows:

On interface 10.0.0.2:

```
router(config-if)# ip helper-address 20.0.0.2
router(config-if)# ip helper-address 20.0.0.3
router(config-if)# ip helper-address 20.0.0.4
```

On interface 20.0.0.1

```
router(config-if)# ip helper-address 10.0.0.1
```

Figure 3-2 Relay Device Used in Autoconfiguration

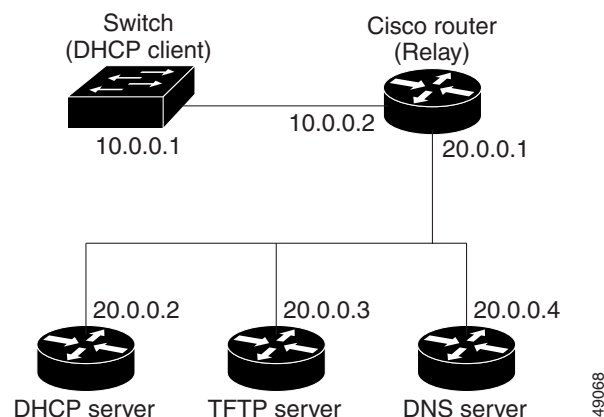

Obtaining Configuration Files

Depending on the availability of the IP address and the configuration filename in the DHCP reserved lease, the switch obtains its configuration information in these ways:

- The IP address and the configuration filename is reserved for the switch and provided in the DHCP reply (one-file read method).

The switch receives its IP address, subnet mask, TFTP server address, and the configuration filename from the DHCP server. The switch sends a unicast message to the TFTP server to retrieve the named configuration file from the base directory of the server and upon receipt, it completes its boot-up process.

- The IP address and the configuration filename is reserved for the switch, but the TFTP server address is not provided in the DHCP reply (one-file read method).

The switch receives its IP address, subnet mask, and the configuration filename from the DHCP server. The switch sends a broadcast message to a TFTP server to retrieve the named configuration file from the base directory of the server, and upon receipt, it completes its boot-up process.

- Only the IP address is reserved for the switch and provided in the DHCP reply. The configuration filename is not provided (two-file read method).

The switch receives its IP address, subnet mask, and the TFTP server address from the DHCP server. The switch sends a unicast message to the TFTP server to retrieve the network-config or cisco.net.cfg default configuration file. (If the network-config file cannot be read, the switch reads the cisco.net.cfg file.)

The default configuration file contains the hostnames-to-IP-address mapping for the switch. The switch fills its host table with the information in the file and obtains its hostname. If the hostname is not found in the file, the switch uses the hostname in the DHCP reply. If the hostname is not specified in the DHCP reply, the switch uses the default *Switch* as its hostname.

After obtaining its hostname from the default configuration file or the DHCP reply, the switch reads the configuration file that has the same name as its hostname (*hostname-confg* or *hostname.cfg*, depending on whether *network-confg* or *cisconet.cfg* was read earlier) from the TFTP server. If the *cisconet.cfg* file is read, the filename of the host is truncated to eight characters.

If the switch cannot read the *network-confg*, *cisconet.cfg*, or the hostname file, it reads the *router-confg* file. If the switch cannot read the *router-confg* file, it reads the *ciscorttr.cfg* file.

**Note**

The switch broadcasts TFTP server requests if the TFTP server is not obtained from the DHCP replies, if all attempts to read the configuration file through unicast transmissions fail, or if the TFTP server name cannot be resolved to an IP address.

Example Configuration

Figure 3-3 shows a sample network for retrieving IP information by using DHCP-based autoconfiguration.

Figure 3-3 DHCP-Based Autoconfiguration Network Example

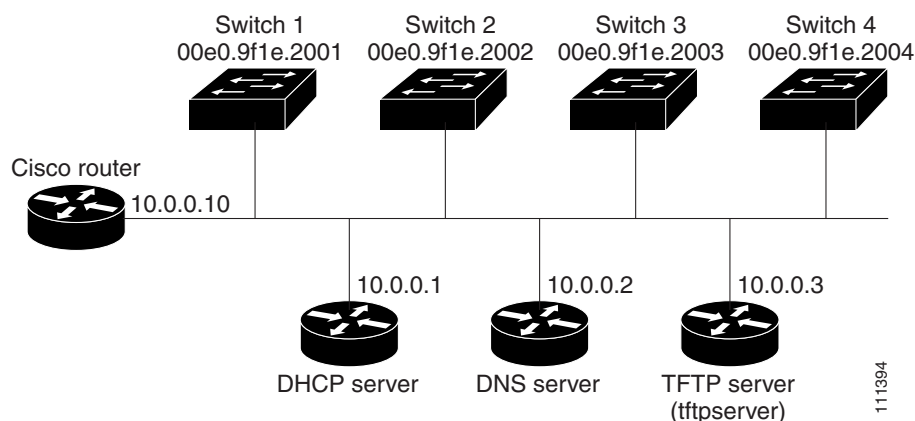

Table 3-2 shows the configuration of the reserved leases on the DHCP server.

Table 3-2 DHCP Server Configuration

	Switch A	Switch B	Switch C	Switch D
Binding key (hardware address)	00e0.9f1e.2001	00e0.9f1e.2002	00e0.9f1e.2003	00e0.9f1e.2004
IP address	10.0.0.21	10.0.0.22	10.0.0.23	10.0.0.24
Subnet mask	255.255.255.0	255.255.255.0	255.255.255.0	255.255.255.0
Router address	10.0.0.10	10.0.0.10	10.0.0.10	10.0.0.10
DNS server address	10.0.0.2	10.0.0.2	10.0.0.2	10.0.0.2
TFTP server name	<i>tftpserver</i> or <i>10.0.0.3</i>	<i>tftpserver</i> or <i>10.0.0.3</i>	<i>tftpserver</i> or <i>10.0.0.3</i>	<i>tftpserver</i> or <i>10.0.0.3</i>

Table 3-2 DHCP Server Configuration (continued)

	Switch A	Switch B	Switch C	Switch D
Boot filename (configuration file) (optional)	switcha-confg	switchb-confg	switchc-confg	switchd-confg
Hostname (optional)	switcha	switchb	switchc	switchd

DNS Server Configuration

The DNS server maps the TFTP server name *tftpserver* to IP address 10.0.0.3.

TFTP Server Configuration (on UNIX)

The TFTP server base directory is set to */tftpserver/work/*. This directory contains the *network-confg* file used in the two-file read method. This file contains the hostname to be assigned to the switch based on its IP address. The base directory also contains a configuration file for each switch (*switcha-confg*, *switchb-confg*, and so forth) as shown in this display:

```
prompt> cd /tftpserver/work/
prompt> ls
network-confg
switcha-confg
switchb-confg
switchc-confg
switchd-confg
prompt> cat network-confg
ip host switcha 10.0.0.21
ip host switchb 10.0.0.22
ip host switchc 10.0.0.23
ip host switchd 10.0.0.24
```

DHCP Client Configuration

No configuration file is present on Switch A through Switch D.

Configuration Explanation

In [Figure 3-3](#), Switch A reads its configuration file as follows:

- It obtains its IP address 10.0.0.21 from the DHCP server.
- If no configuration filename is given in the DHCP server reply, Switch A reads the *network-confg* file from the base directory of the TFTP server.
- It adds the contents of the *network-confg* file to its host table.
- It reads its host table by indexing its IP address 10.0.0.21 to its hostname (*switcha*).
- It reads the configuration file that corresponds to its hostname; for example, it reads *switch1-confg* from the TFTP server.

Switches B through D retrieve their configuration files and IP addresses in the same way.

Manually Assigning IP Information

Beginning in privileged EXEC mode, follow these steps to manually assign IP information to multiple switched virtual interfaces (SVIs):

	Command	Purpose
Step 1	configure terminal	Enter global configuration mode.
Step 2	interface vlan <i>vlan-id</i>	Enter interface configuration mode, and enter the VLAN to which the IP information is assigned. The VLAN range is 1 to 4094.
Step 3	ip address <i>ip-address subnet-mask</i>	Enter the IP address and subnet mask.
Step 4	exit	Return to global configuration mode.
Step 5	ip default-gateway <i>ip-address</i>	Enter the IP address of the next-hop router interface that is directly connected to the switch where a default gateway is being configured. The default gateway receives IP packets with unresolved destination IP addresses from the switch. Once the default gateway is configured, the switch has connectivity to the remote networks with which a host needs to communicate. Note When your switch is configured to route with IP, it does not need to have a default gateway set.
Step 6	end	Return to privileged EXEC mode.
Step 7	show interfaces vlan <i>vlan-id</i>	Verify the configured IP address.
Step 8	show ip redirects	Verify the configured default gateway.
Step 9	copy running-config startup-config	(Optional) Save your entries in the configuration file.

To remove the switch IP address, use the **no ip address** interface configuration command. If you are removing the address through a Telnet session, your connection to the switch will be lost. To remove the default gateway address, use the **no ip default-gateway** global configuration command.

For information on setting the switch system name, protecting access to privileged EXEC commands, and setting time and calendar services, see [Chapter 6, “Administering the Switch.”](#)

Checking and Saving the Running Configuration

You can check the configuration settings that you entered or changes that you made by entering this privileged EXEC command:

```
Switch# show running-config
Building configuration...

Current configuration: 1363 bytes
!
version 12.1
no service pad
service timestamps debug uptime
service timestamps log uptime
no service password-encryption
!
hostname Switch A
!
```

```
enable secret 5 $1$ej9.$DMUvAUnZOAmvmgqBEzIxEO
!
.
<output truncated>
.
interface gigabitethernet0/1
ip address 172.20.137.50 255.255.255.0
!
interface gigabitethernet0/2
mvr type source

<output truncated>

...!
interface VLAN1
 ip address 172.20.137.50 255.255.255.0
 no ip directed-broadcast
!
ip default-gateway 172.20.137.1 !
!
snmp-server community private RW
snmp-server community public RO
snmp-server community private@es0 RW
snmp-server community public@es0 RO
snmp-server chassis-id 0x12
!
end
```

To store the configuration or changes you have made to your startup configuration in flash memory, enter this privileged EXEC command:

```
Switch# copy running-config startup-config
Destination filename [startup-config]?
Building configuration...
```

This command saves the configuration settings that you made. If you fail to do this, your configuration will be lost the next time you reload the system. To display information stored in the NVRAM section of flash memory, use the **show startup-config** or **more startup-config** privileged EXEC command.

For more information about alternative locations from which to copy the configuration file, see [Appendix B, “Working with the Cisco IOS File System, Configuration Files, and Software Images.”](#)

Modifying the Startup Configuration

These sections describe how to modify the switch startup configuration:

- [Default Boot Configuration, page 3-12](#)
- [Automatically Downloading a Configuration File, page 3-12](#)
- [Booting Manually, page 3-13](#)
- [Booting a Specific Software Image, page 3-14](#)
- [Controlling Environment Variables, page 3-14](#)

See also [Appendix B, “Working with the Cisco IOS File System, Configuration Files, and Software Images,”](#) for information about switch configuration files.

Default Boot Configuration

Table 3-3 shows the default boot-up configuration.

Table 3-3 Default Boot Configuration

Feature	Default Setting
Operating system software image	<p>The switch attempts to automatically boot up the system using information in the BOOT environment variable. If the variable is not set, the switch attempts to load and execute the first executable image it can by performing a recursive, depth-first search throughout the flash file system.</p> <p>The Cisco IOS image is stored in a directory that has the same name as the image file (excluding the .bin extension).</p> <p>In a depth-first search of a directory, each encountered subdirectory is completely searched before continuing the search in the original directory.</p>
Configuration file	<p>Configured switches use the <i>config.text</i> file stored on the system board in flash memory.</p> <p>A new switch has no configuration file.</p>

Automatically Downloading a Configuration File

You can automatically download a configuration file to your switch by using the DHCP-based autoconfiguration feature. For more information, see the [“Understanding DHCP-Based Autoconfiguration”](#) section on page 3-3.

Specifying the Filename to Read and Write the System Configuration

By default, the Cisco IOS software uses the file *config.text* to read and write a nonvolatile copy of the system configuration. However, you can specify a different filename, which will be loaded during the next boot-up cycle.

Beginning in privileged EXEC mode, follow these steps to specify a different configuration filename:

	Command	Purpose
Step 1	configure terminal	Enter global configuration mode.
Step 2	boot config-file flash:/file-url	<p>Specify the configuration file to load during the next boot-up cycle.</p> <p>For <i>file-url</i>, specify the path (directory) and the configuration filename.</p> <p>Filenames and directory names are case sensitive.</p>
Step 3	end	Return to privileged EXEC mode.
Step 4	show boot	<p>Verify your entries.</p> <p>The boot config-file global configuration command changes the setting of the CONFIG_FILE environment variable.</p>
Step 5	copy running-config startup-config	(Optional) Save your entries in the configuration file.

To return to the default setting, use the **no boot config-file** global configuration command.

Booting Manually

By default, the switch automatically boots up; however, you can configure it to manually boot up.

Beginning in privileged EXEC mode, follow these steps to configure the switch to manually boot up during the next boot cycle:

	Command	Purpose
Step 1	configure terminal	Enter global configuration mode.
Step 2	boot manual	Enable the switch to manually boot up during the next boot cycle.
Step 3	end	Return to privileged EXEC mode.
Step 4	show boot	Verify your entries. The boot manual global command changes the setting of the MANUAL_BOOT environment variable. The next time you reboot the system, the switch is in boot loader mode, shown by the <i>switch:</i> prompt. To boot up the system, use the boot filesystem:/file-url boot loader command. <ul style="list-style-type: none"> • For <i>filesystem:</i>, use flash: for the system board flash device. • For <i>file-url</i>, specify the path (directory) and the name of the bootable image. Filenames and directory names are case sensitive.
Step 5	copy running-config startup-config	(Optional) Save your entries in the configuration file.

To disable manual booting, use the **no boot manual** global configuration command.

Booting a Specific Software Image

By default, the switch attempts to automatically boot up the system using information in the `BOOT` environment variable. If this variable is not set, the switch attempts to load and execute the first executable image it can by performing a recursive, depth-first search throughout the flash file system. In a depth-first search of a directory, each encountered subdirectory is completely searched before continuing the search in the original directory. However, you can specify a specific image to boot up.

Beginning in privileged EXEC mode, follow these steps to configure the switch to boot a specific image during the next boot cycle:

	Command	Purpose
Step 1	<code>configure terminal</code>	Enter global configuration mode.
Step 2	<code>boot system filesystem:/file-url</code>	Configure the switch to boot a specific image in flash memory during the next boot cycle. <ul style="list-style-type: none"> For <code>filesystem:</code>, use <code>flash:</code> for the system board flash device. For <code>file-url</code>, specify the path (directory) and the name of the bootable image. Filenames and directory names are case sensitive.
Step 3	<code>end</code>	Return to privileged EXEC mode.
Step 4	<code>show boot</code>	Verify your entries. The <code>boot system</code> global command changes the setting of the <code>BOOT</code> environment variable. During the next boot cycle, the switch attempts to automatically boot up the system using information in the <code>BOOT</code> environment variable.
Step 5	<code>copy running-config startup-config</code>	(Optional) Save your entries in the configuration file.

To return to the default setting, use the `no boot system` global configuration command.

Controlling Environment Variables

With a normally operating switch, you enter the boot loader mode only through a switch console connection configured for 9600 b/s. Unplug the switch power cord, and press the switch **Mode** button while reconnecting the power cord. You can release the **Mode** button a second or two after the LED above port 1 turns off. Then the boot loader `switch:` prompt appears.

The switch boot loader software provides support for nonvolatile environment variables, which can be used to control how the boot loader, or any other software running on the system, behaves. Boot loader environment variables are similar to environment variables that can be set on UNIX or DOS systems.

Environment variables that have values are stored in flash memory outside of the flash file system.

Each line in these files contains an environment variable name and an equal sign followed by the value of the variable. A variable has no value if it is not listed in this file; it has a value if it is listed in the file even if the value is a null string. A variable that is set to a null string (for example, “”) is a variable with a value. Many environment variables are predefined and have default values.

Environment variables store two kinds of data:

- Data that controls code, which does not read the Cisco IOS configuration file. For example, the name of a boot loader helper file, which extends or patches the functionality of the boot loader can be stored as an environment variable.
- Data that controls code, which is responsible for reading the Cisco IOS configuration file. For example, the name of the Cisco IOS configuration file can be stored as an environment variable.

You can change the settings of the environment variables by accessing the boot loader or by using Cisco IOS commands. Under normal circumstances, it is not necessary to alter the setting of the environment variables.



Note

For complete syntax and usage information for the boot loader commands and environment variables, see the command reference for this release.

Table 3-4 describes the function of the most common environment variables.

Table 3-4 Environment Variables

Variable	Boot Loader Command	Cisco IOS Global Configuration Command
BOOT	<p>set BOOT <i>filesystem:/file-url ...</i></p> <p>A semicolon-separated list of executable files to try to load and execute when automatically booting. If the BOOT environment variable is not set, the system attempts to load and execute the first executable image it can find by using a recursive, depth-first search through the flash file system. If the BOOT variable is set but the specified images cannot be loaded, the system attempts to boot the first bootable file that it can find in the flash file system.</p>	<p>boot system <i>filesystem:/file-url ...</i></p> <p>Specifies the Cisco IOS image to load during the next boot cycle. This command changes the setting of the BOOT environment variable.</p>
MANUAL_BOOT	<p>set MANUAL_BOOT yes</p> <p>Decides whether the switch automatically or manually boots up.</p> <p>Valid values are 1, yes, 0, and no. If it is set to no or 0, the boot loader attempts to automatically boot up the system. If it is set to anything else, you must manually boot up the switch from the boot loader mode.</p>	<p>boot manual</p> <p>Enables manually booting up the switch during the next boot cycle and changes the setting of the MANUAL_BOOT environment variable.</p> <p>The next time you reboot the system, the switch is in boot loader mode. To boot up the system, use the boot flash:filesystem:/file-url boot loader command, and specify the name of the bootable image.</p>
CONFIG_FILE	<p>set CONFIG_FILE flash:/file-url</p> <p>Changes the filename that Cisco IOS uses to read and write a nonvolatile copy of the system configuration.</p>	<p>boot config-file flash:/file-url</p> <p>Specifies the filename that Cisco IOS uses to read and write a nonvolatile copy of the system configuration. This command changes the CONFIG_FILE environment variable.</p>

Scheduling a Reload of the Software Image

You can schedule a reload of the software image to occur on the switch at a later time (for example, late at night or during the weekend when the switch is used less), or you can synchronize a reload network-wide (for example, to perform a software upgrade on all switches in the network).

Note

A scheduled reload must take place within approximately 24 days.

Configuring a Scheduled Reload

To configure your switch to reload the software image at a later time, use one of these commands in privileged EXEC mode:

- **reload in** [*hh:*]*mm* [*text*]

This command schedules a reload of the software to take effect in the specified minutes or hours and minutes. The reload must take place within approximately 24 days. You can specify the reason for the reload in a string up to 255 characters in length.

- **reload at** *hh:mm* [*month day* | *day month*] [*text*]

This command schedules a reload of the software to take place at the specified time (using a 24-hour clock). If you specify the month and day, the reload is scheduled to take place at the specified time and date. If you do not specify the month and day, the reload takes place at the specified time on the current day (if the specified time is later than the current time) or on the next day (if the specified time is earlier than the current time). Specifying 00:00 schedules the reload for midnight.

Note

Use the **at** keyword only if the switch system clock has been set (through Network Time Protocol (NTP), the hardware calendar, or manually). The time is relative to the configured time zone on the switch. To schedule reloads across several switches to occur simultaneously, the time on each switch must be synchronized with NTP.

The **reload** command halts the system. If the system is not set to manually boot up, it reboots itself. Use the **reload** command after you save the switch configuration information to the startup configuration (**copy running-config startup-config**).

If your switch is configured for manual booting, do not reload it from a virtual terminal. This restriction prevents the switch from entering the boot loader mode and thereby taking it from the remote user's control.

If you modify your configuration file, the switch prompts you to save the configuration before reloading. During the save operation, the system requests whether you want to proceed with the save if the CONFIG_FILE environment variable points to a startup configuration file that no longer exists. If you proceed in this situation, the system enters setup mode upon reload.

This example shows how to reload the software on the switch on the current day at 7:30 p.m.:

```
Switch# reload at 19:30
Reload scheduled for 19:30:00 UTC Wed Jun 5 1996 (in 2 hours and 25 minutes)
Proceed with reload? [confirm]
```

This example shows how to reload the software on the switch at a future time:

```
Switch# reload at 02:00 jun 20
Reload scheduled for 02:00:00 UTC Thu Jun 20 1996 (in 344 hours and 53 minutes)
Proceed with reload? [confirm]
```

To cancel a previously scheduled reload, use the **reload cancel** privileged EXEC command.

Displaying Scheduled Reload Information

To display information about a previously scheduled reload or to find out if a reload has been scheduled on the switch, use the **show reload** privileged EXEC command.

It displays reload information including the time the reload is scheduled to occur and the reason for the reload (if it was specified when the reload was scheduled).



CHAPTER 4

Configuring Cisco IOS CNS Agents

This chapter describes how to configure the Cisco IOS CNS agents on the Catalyst 2960 switch.



Note

For complete configuration information for the Cisco Configuration Engine, see this URL on Cisco.com http://www.cisco.com/en/US/products/sw/netmgsw/ps4617/tsd_products_support_series_home.html

This chapter consists of these sections:

- [Understanding Cisco Configuration Engine Software, page 4-1](#)
- [Understanding Cisco IOS Agents, page 4-5](#)
- [Configuring Cisco IOS Agents, page 4-6](#)
- [Displaying CNS Configuration, page 4-12](#)

Understanding Cisco Configuration Engine Software

The Cisco Configuration Engine is network management software that acts as a configuration service for automating the deployment and management of network devices and services (see [Figure 4-1](#)). Each Configuration Engine manages a group of Cisco devices (switches and routers) and the services that they deliver, storing their configurations and delivering them as needed. The Configuration Engine automates initial configurations and configuration updates by generating device-specific configuration changes, sending them to the device, executing the configuration change, and logging the results.

The Configuration Engine supports standalone and server modes and has these CNS components:

- Configuration service (web server, file manager, and namespace mapping server)
- Event service (event gateway)
- Data service directory (data models and schema)

In standalone mode, the Configuration Engine supports an embedded Directory Service. In this mode, no external directory or other data store is required. In server mode, the Configuration Engine supports the use of a user-defined external directory.

Figure 4-1 Configuration Engine Architectural Overview

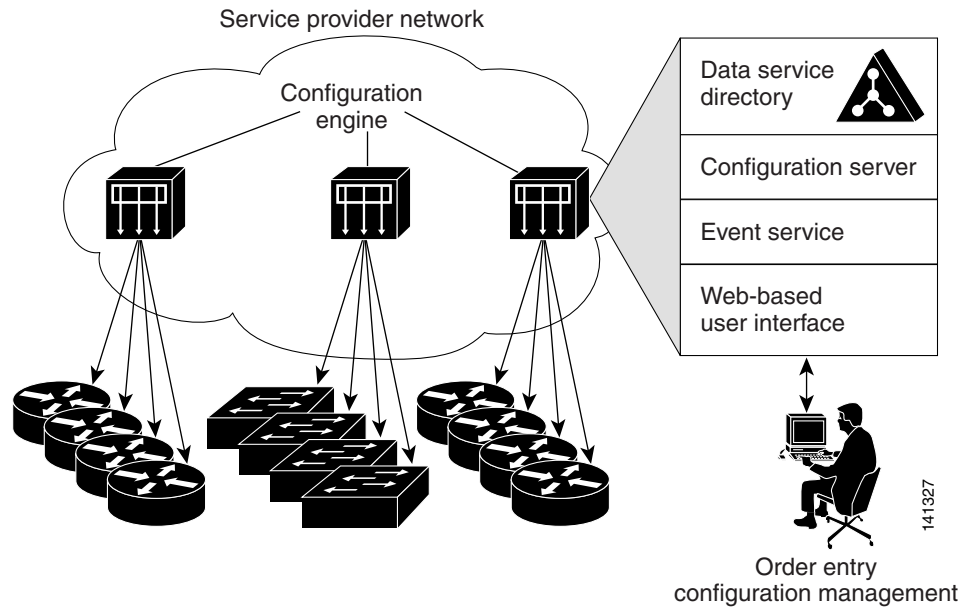

These sections contain this conceptual information:

- [Configuration Service, page 4-2](#)
- [Event Service, page 4-3](#)
- [What You Should Know About the CNS IDs and Device Hostnames, page 4-3](#)

Configuration Service

The Configuration Service is the core component of the Cisco Configuration Engine. It consists of a configuration server that works with Cisco IOS CNS agents on the switch. The Configuration Service delivers device and service configurations to the switch for initial configuration and mass reconfiguration by logical groups. Switches receive their initial configuration from the Configuration Service when they start up on the network for the first time.

The Configuration Service uses the CNS Event Service to send and receive configuration change events and to send success and failure notifications.

The configuration server is a web server that uses configuration templates and the device-specific configuration information stored in the embedded (standalone mode) or remote (server mode) directory.

Configuration templates are text files containing static configuration information in the form of CLI commands. In the templates, variables are specified using lightweight directory access protocol (LDAP) URLs that reference the device-specific configuration information stored in a directory.

The Cisco IOS agent can perform a syntax check on received configuration files and publish events to show the success or failure of the syntax check. The configuration agent can either apply configurations immediately or delay the application until receipt of a synchronization event from the configuration server.

Event Service

The Cisco Configuration Engine uses the Event Service for receipt and generation of configuration events. The event agent is on the switch and facilitates the communication between the switch and the event gateway on the Configuration Engine.

The Event Service is a highly capable publish-and-subscribe communication method. The Event Service uses subject-based addressing to send messages to their destinations. Subject-based addressing conventions define a simple, uniform namespace for messages and their destinations.

NameSpace Mapper

The Configuration Engine includes the NameSpace Mapper (NSM) that provides a lookup service for managing logical groups of devices based on application, device or group ID, and event.

Cisco IOS devices recognize only event subject-names that match those configured in Cisco IOS software; for example, `cisco.cns.config.load`. You can use the namespace mapping service to designate events by using any desired naming convention. When you have populated your data store with your subject names, NSM changes your event subject-name strings to those known by Cisco IOS.

For a subscriber, when given a unique device ID and event, the namespace mapping service returns a set of events to which to subscribe. Similarly, for a publisher, when given a unique group ID, device ID, and event, the mapping service returns a set of events on which to publish.

What You Should Know About the CNS IDs and Device Hostnames

The Cisco Configuration Engine assumes that a unique identifier is associated with each configured switch. This unique identifier can take on multiple synonyms, where each synonym is unique within a particular namespace. The event service uses namespace content for subject-based addressing of messages.

The Configuration Engine intersects two namespaces, one for the event bus and the other for the configuration server. Within the scope of the configuration server namespace, the term *ConfigID* is the unique identifier for a device. Within the scope of the event bus namespace, the term *DeviceID* is the CNS unique identifier for a device.

Because the Configuration Engine uses both the event bus and the configuration server to provide configurations to devices, you must define both ConfigID and Device ID for each configured switch.

Within the scope of a single instance of the configuration server, no two configured switches can share the same value for ConfigID. Within the scope of a single instance of the event bus, no two configured switches can share the same value for DeviceID.

ConfigID

Each configured switch has a unique ConfigID, which serves as the key into the Configuration Engine directory for the corresponding set of switch CLI attributes. The ConfigID defined on the switch must match the ConfigID for the corresponding switch definition on the Configuration Engine.

The ConfigID is fixed at startup time and cannot be changed until the device restarts, even if the switch hostname is reconfigured.

DeviceID

Each configured switch participating on the event bus has a unique DeviceID, which is analogous to the switch source address so that the switch can be targeted as a specific destination on the bus. All switches configured with the **cns config partial** global configuration command must access the event bus. Therefore, the DeviceID, as originated on the switch, must match the DeviceID of the corresponding switch definition in the Configuration Engine.

The origin of the DeviceID is defined by the Cisco IOS hostname of the switch. However, the DeviceID variable and its usage reside within the event gateway adjacent to the switch.

The logical Cisco IOS termination point on the event bus is embedded in the event gateway, which in turn functions as a proxy on behalf of the switch. The event gateway represents the switch and its corresponding DeviceID to the event bus.

The switch declares its hostname to the event gateway immediately after the successful connection to the event gateway. The event gateway couples the DeviceID value to the Cisco IOS hostname each time this connection is established. The event gateway caches this DeviceID value for the duration of its connection to the switch.

Hostname and DeviceID

The DeviceID is fixed at the time of the connection to the event gateway and does not change even when the switch hostname is reconfigured.

When changing the switch hostname on the switch, the only way to refresh the DeviceID is to break the connection between the switch and the event gateway. Enter the **no cns event** global configuration command followed by the **cns event** global configuration command.

When the connection is re-established, the switch sends its modified hostname to the event gateway. The event gateway redefines the DeviceID to the new value.



Caution

When using the Configuration Engine user interface, you must first set the DeviceID field to the hostname value that the switch acquires *after*—not *before*—you use the **cns config initial** global configuration command at the switch. Otherwise, subsequent **cns config partial** global configuration command operations malfunction.

Using Hostname, DeviceID, and ConfigID

In standalone mode, when a hostname value is set for a switch, the configuration server uses the hostname as the DeviceID when an event is sent on hostname. If the hostname has not been set, the event is sent on the `cn=<value>` of the device.

In server mode, the hostname is not used. In this mode, the unique DeviceID attribute is always used for sending an event on the bus. If this attribute is not set, you cannot update the switch.

These and other associated attributes (tag value pairs) are set when you run **Setup** on the Configuration Engine.



Note

For more information about running the setup program on the Configuration Engine, see the Configuration Engine setup and configuration guide at this URL on cisco.com:
http://www.cisco.com/en/US/products/sw/netmgsw/ps4617/products_installation_and_configuration_guide_book09186a00803b59db.html

Understanding Cisco IOS Agents

The CNS event agent feature allows the switch to publish and subscribe to events on the event bus and works with the Cisco IOS agent. The Cisco IOS agent feature supports the switch by providing these features:

- [Initial Configuration, page 4-5](#)
- [Incremental \(Partial\) Configuration, page 4-6](#)
- [Synchronized Configuration, page 4-6](#)

Initial Configuration

When the switch first comes up, it attempts to get an IP address by broadcasting a DHCP request on the network. Assuming there is no DHCP server on the subnet, the distribution switch acts as a DHCP relay agent and forwards the request to the DHCP server. Upon receiving the request, the DHCP server assigns an IP address to the new switch and includes the TFTP server IP address, the path to the bootstrap configuration file, and the default gateway IP address in a unicast reply to the DHCP relay agent. The DHCP relay agent forwards the reply to the switch.

The switch automatically configures the assigned IP address on interface VLAN 1 (the default) and downloads the bootstrap configuration file from the TFTP server. Upon successful download of the bootstrap configuration file, the switch loads the file in its running configuration.

The Cisco IOS agents initiate communication with the Configuration Engine by using the appropriate ConfigID and EventID. The Configuration Engine maps the Config ID to a template and downloads the full configuration file to the switch.

[Figure 4-2](#) shows a sample network configuration for retrieving the initial bootstrap configuration file by using DHCP-based autoconfiguration.

Figure 4-2 Initial Configuration Overview

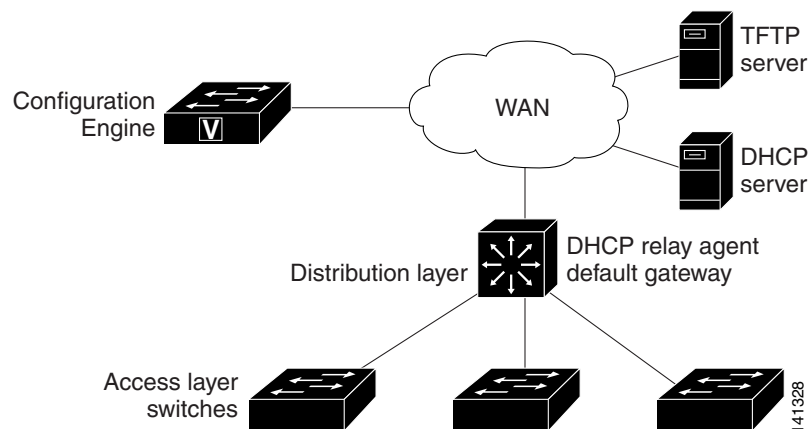

Incremental (Partial) Configuration

After the network is running, new services can be added by using the Cisco IOS agent. Incremental (partial) configurations can be sent to the switch. The actual configuration can be sent as an event payload by way of the event gateway (push operation) or as a signal event that triggers the switch to initiate a pull operation.

The switch can check the syntax of the configuration before applying it. If the syntax is correct, the switch applies the incremental configuration and publishes an event that signals success to the configuration server. If the switch does not apply the incremental configuration, it publishes an event showing an error status. When the switch has applied the incremental configuration, it can write it to NVRAM or wait until signaled to do so.

Synchronized Configuration

When the switch receives a configuration, it can defer application of the configuration upon receipt of a write-signal event. The write-signal event tells the switch not to save the updated configuration into its NVRAM. The switch uses the updated configuration as its running configuration. This ensures that the switch configuration is synchronized with other network activities before saving the configuration in NVRAM for use at the next reboot.

Configuring Cisco IOS Agents

The Cisco IOS agents embedded in the switch Cisco IOS software allow the switch to be connected and automatically configured as described in the [“Enabling Automated CNS Configuration” section on page 4-6](#). If you want to change the configuration or install a custom configuration, see these sections for instructions:

- [Enabling the CNS Event Agent, page 4-8](#)
- [Enabling the Cisco IOS CNS Agent, page 4-9](#)

Enabling Automated CNS Configuration

To enable automated CNS configuration of the switch, you must first complete the prerequisites in [Table 4-1](#). When you complete them, power on the switch. At the **setup** prompt, do nothing: The switch begins the initial configuration as described in the [“Initial Configuration” section on page 4-5](#). When the full configuration file is loaded on your switch, you need to do nothing else.

Table 4-1 Prerequisites for Enabling Automatic Configuration

Device	Required Configuration
Access switch	Factory default (no configuration file)
Distribution switch	<ul style="list-style-type: none"> • IP helper address • Enable DHCP relay agent • IP routing (if used as default gateway)
DHCP server	<ul style="list-style-type: none"> • IP address assignment • TFTP server IP address • Path to bootstrap configuration file on the TFTP server • Default gateway IP address
TFTP server	<ul style="list-style-type: none"> • A bootstrap configuration file that includes the CNS configuration commands that enable the switch to communicate with the Configuration Engine • The switch configured to use either the switch MAC address or the serial number (instead of the default hostname) to generate the ConfigID and EventID • The CNS event agent configured to push the configuration file to the switch
CNS Configuration Engine	One or more templates for each type of device, with the ConfigID of the device mapped to the template.

**Note**

For more information about running the setup program and creating templates on the Configuration Engine, see the *Cisco Configuration Engine Installation and Setup Guide, 1.5 for Linux* at this URL: http://www.cisco.com/en/US/products/sw/netmgtsw/ps4617/products_installation_and_configuration_guide_book09186a00803b59db.html

Enabling the CNS Event Agent

Note

You must enable the CNS event agent on the switch before you enable the CNS configuration agent.

Beginning in privileged EXEC mode, follow these steps to enable the CNS event agent on the switch:

	Command	Purpose
Step 1	configure terminal	Enter global configuration mode.
Step 2	cns event { <i>ip-address</i> <i>hostname</i> } [<i>port-number</i>] [backup] [init-retry <i>retry-count</i>] [keepalive <i>seconds</i> <i>retry-count</i>] [source <i>ip-address</i>]	Enable the event agent, and enter the gateway parameters. <ul style="list-style-type: none"> For {<i>ip-address</i> <i>hostname</i>}, enter either the IP address or the hostname of the event gateway. (Optional) For <i>port number</i>, enter the port number for the event gateway. The default port number is 11011. (Optional) Enter backup to show that this is the backup gateway. (If omitted, this is the primary gateway.) (Optional) For init-retry <i>retry-count</i>, enter the number of initial retries before switching to backup. The default is 3. (Optional) For keepalive <i>seconds</i>, enter how often the switch sends keepalive messages. For <i>retry-count</i>, enter the number of unanswered keepalive messages that the switch sends before the connection is terminated. The default for each is 0. (Optional) For source <i>ip-address</i>, enter the source IP address of this device. Note Though visible in the command-line help string, the encrypt and force-fmt1 keywords are not supported.
Step 3	end	Return to privileged EXEC mode.
Step 4	show cns event connections	Verify information about the event agent.
Step 5	show running-config	Verify your entries.
Step 6	copy running-config startup-config	(Optional) Save your entries in the configuration file.

To disable the CNS event agent, use the **no cns event** {*ip-address* | *hostname*} global configuration command.

This example shows how to enable the CNS event agent, set the IP address gateway to 10.180.1.27, set 120 seconds as the keepalive interval, and set 10 as the retry count.

```
Switch(config)# cns event 10.180.1.27 keepalive 120 10
```

Enabling the Cisco IOS CNS Agent

After enabling the CNS event agent, start the Cisco IOS CNS agent on the switch. You can enable the Cisco IOS agent with these commands:

- The **cns config initial** global configuration command enables the Cisco IOS agent and initiates an initial configuration on the switch.
- The **cns config partial** global configuration command enables the Cisco IOS agent and initiates a partial configuration on the switch. You can then use the Configuration Engine to remotely send incremental configurations to the switch.

Enabling an Initial Configuration

Beginning in privileged EXEC mode, follow these steps to enable the CNS configuration agent and initiate an initial configuration on the switch:

	Command	Purpose
Step 1	configure terminal	Enter global configuration mode.
Step 2	cns config connect-intf <i>interface-prefix</i> [ping-interval <i>seconds</i>] [retries <i>num</i>]	Enter the connect-interface-config submode, and specify the interface for connecting to the Configuration Engine. <ul style="list-style-type: none"> • Enter the <i>interface-prefix</i> for the connecting interface. You must specify the interface type but need not specify the interface number. • (Optional) For ping-interval <i>seconds</i>, enter the interval between successive ping attempts. The range is 1 to 30 seconds. The default is 10 seconds. • (Optional) For retries <i>num</i>, enter the number of ping retries. The range is 1 to 30. The default is 5.
Step 3	config-cli or line-cli	Enter config-cli to connect to the Configuration Engine through the interface defined in cns config connect-intf . Enter line-cli to connect to the Configuration Engine through modem dialup lines. <p>Note The config-cli interface configuration command accepts the special character & that acts as a placeholder for the interface name. When the configuration is applied, the & is replaced with the interface name. For example, to connect through FastEthernet0/1, the command config-cli ip route 0.0.0.0 0.0.0.0 & generates the command ip route 0.0.0.0 0.0.0.0 FastEthernet0/1.</p>
Step 4	exit	Return to global configuration mode.
Step 5	hostname <i>name</i>	Enter the hostname for the switch.
Step 6	ip route <i>network-number</i>	Establish a static route to the Configuration Engine whose IP address is <i>network-number</i> .

	Command	Purpose
Step 7	<p>cns id <i>interface num</i> {dns-reverse ipaddress mac-address} [event]</p> <p>or</p> <p>cns id {hardware-serial hostname string string} [event]</p>	<p>Set the unique EventID or ConfigID used by the Configuration Engine.</p> <ul style="list-style-type: none"> For <i>interface num</i>, enter the type of interface—for example, Ethernet, Group-Async, Loopback, or Virtual-Template. This setting specifies from which interface the IP or MAC address should be retrieved to define the unique ID. For {dns-reverse ipaddress mac-address} enter dns-reverse to retrieve the hostname and assign it as the unique ID, enter ipaddress to use the IP address, or enter mac-address to use the MAC address as the unique ID. (Optional) Enter event to set the ID to be the event-id value used to identify the switch. For {hardware-serial hostname string string}, enter hardware-serial to set the switch serial number as the unique ID, enter hostname (the default) to select the switch hostname as the unique ID, or enter an arbitrary text string for string string as the unique ID.
Step 8	<p>cns config initial {<i>ip-address</i> <i>hostname</i>} [<i>port-number</i>] [event] [no-persist] [page page] [source ip-address] [syntax-check]</p>	<p>Enable the Cisco IOS agent, and initiate an initial configuration.</p> <ul style="list-style-type: none"> For {<i>ip-address</i> <i>hostname</i>}, enter the IP address or the hostname of the configuration server. (Optional) For <i>port-number</i>, enter the port number of the configuration server. The default port number is 80. (Optional) Enable event for configuration success, failure, or warning messages when the configuration is finished. (Optional) Enable no-persist to suppress the automatic writing to NVRAM of the configuration pulled as a result of entering the cns config initial global configuration command. If the no-persist keyword is not entered, using the cns config initial command causes the resultant configuration to be automatically written to NVRAM. (Optional) For page page, enter the web page of the initial configuration. The default is /Config/config/asp. (Optional) Enter source ip-address to use for source IP address. (Optional) Enable syntax-check to check the syntax when this parameter is entered. <p>Note Though visible in the command-line help string, the encrypt keyword is not supported.</p>
Step 9	end	Return to privileged EXEC mode.

	Command	Purpose
Step 10	show cns config connections	Verify information about the configuration agent.
Step 11	show running-config	Verify your entries.

To disable the CNS Cisco IOS agent, use the **no cns config initial** *{ip-address | hostname}* global configuration command.

This example shows how to configure an initial configuration on a remote switch. The switch hostname is the unique ID. The Cisco Configuration Engine IP address is 172.28.129.22.

```
Switch(config)# cns config connect-intf serial ping-interval 1 retries 1
Switch(config-cns-conn-if)# config-cli ip address negotiated
Switch(config-cns-conn-if)# config-cli encapsulation ppp
Switch(config-cns-conn-if)# config-cli ip directed-broadcast
Switch(config-cns-conn-if)# config-cli no keepalive
Switch(config-cns-conn-if)# config-cli no shutdown
Switch(config-cns-conn-if)# exit
Switch(config)# hostname RemoteSwitch
RemoteSwitch(config)# ip route 10.1.1.1 255.255.255.255 11.11.11.1
RemoteSwitch(config)# cns id Ethernet 0 ipaddress
RemoteSwitch(config)# cns config initial 10.1.1.1 no-persist
```

Enabling a Partial Configuration

Beginning in privileged EXEC mode, follow these steps to enable the Cisco IOS agent and to initiate a partial configuration on the switch:

	Command	Purpose
Step 1	configure terminal	Enter global configuration mode.
Step 2	cns config partial <i>{ip-address hostname}</i> <i>[port-number]</i> <i>[source ip-address]</i>	Enable the configuration agent, and initiate a partial configuration. <ul style="list-style-type: none"> For <i>{ip-address hostname}</i>, enter the IP address or the hostname of the configuration server. (Optional) For <i>port-number</i>, enter the port number of the configuration server. The default port number is 80. (Optional) Enter source ip-address to use for the source IP address. <p>Note Though visible in the command-line help string, the encrypt keyword is not supported.</p>
Step 3	end	Return to privileged EXEC mode.
Step 4	show cns config stats or show cns config outstanding	Verify information about the configuration agent.
Step 5	show running-config	Verify your entries.
Step 6	copy running-config startup-config	(Optional) Save your entries in the configuration file.

To disable the Cisco IOS agent, use the **no cns config partial** *{ip-address | hostname}* global configuration command. To cancel a partial configuration, use the **cns config cancel** privileged EXEC command.

Displaying CNS Configuration

You can use the privileged EXEC commands in [Table 4-2](#) to display CNS configuration information.

Table 4-2 *Displaying CNS Configuration*

Command	Purpose
show cns config connections	Displays the status of the CNS Cisco IOS agent connections.
show cns config outstanding	Displays information about incremental (partial) CNS configurations that have started but are not yet completed.
show cns config stats	Displays statistics about the Cisco IOS agent.
show cns event connections	Displays the status of the CNS event agent connections.
show cns event stats	Displays statistics about the CNS event agent.
show cns event subject	Displays a list of event agent subjects that are subscribed to by applications.



CHAPTER 5

Clustering Switches

This chapter provides the concepts and procedures to create and manage Catalyst 2960 switch clusters. You can create and manage switch clusters by using Cisco Network Assistant (hereafter known as Network Assistant), the command-line interface (CLI), or SNMP. For complete procedures, see the online help. For the CLI cluster commands, see the switch command reference.



Note

Network Assistant supports switch clusters, but we recommend that you instead group switches into *communities*. Network Assistant has a Cluster Conversion Wizard to help you convert a cluster to a community. For more information about Network Assistant, including introductory information on managing switch clusters and converting a switch cluster to a community, see *Getting Started with Cisco Network Assistant*, available on Cisco.com.

This chapter focuses on Catalyst 2960 switch clusters. It also includes guidelines and limitations for clusters mixed with other cluster-capable Catalyst switches, but it does not provide complete descriptions of the cluster features for these other switches. For complete cluster information for a specific Catalyst platform, refer to the software configuration guide for that switch.

This chapter consists of these sections:

- [Understanding Switch Clusters, page 5-1](#)
- [Planning a Switch Cluster, page 5-4](#)
- [Using the CLI to Manage Switch Clusters, page 5-14](#)
- [Using SNMP to Manage Switch Clusters, page 5-15](#)



Note

We do not recommend using the **ip http access-class** global configuration command to limit access to specific hosts or networks. Access should be controlled through the cluster command switch or by applying access control lists (ACLs) on interfaces that are configured with IP address. For more information on ACLs, see [Chapter 34, “Configuring Network Security with ACLs.”](#)

Understanding Switch Clusters

A *switch cluster* is a set of up to 16 connected, cluster-capable Catalyst switches that are managed as a single entity. The switches in the cluster use the switch clustering technology so that you can configure and troubleshoot a group of different Catalyst desktop switch platforms through a single IP address.

In a switch cluster, 1 switch must be the *cluster command switch* and up to 15 other switches can be *cluster member switches*. The total number of switches in a cluster cannot exceed 16 switches. The cluster command switch is the single point of access used to configure, manage, and monitor the cluster member switches. Cluster members can belong to only one cluster at a time.

The benefits of clustering switches include:

- Management of Catalyst switches regardless of their interconnection media and their physical locations. The switches can be in the same location, or they can be distributed across a Layer 2 or Layer 3 (if your cluster is using a Catalyst 3550, Catalyst 3560, or Catalyst 3750 switch as a Layer 3 router between the Layer 2 switches in the cluster) network.

Cluster members are connected to the cluster command switch according to the connectivity guidelines described in the “[Automatic Discovery of Cluster Candidates and Members](#)” section on [page 5-4](#). This section includes management VLAN considerations for the Catalyst 1900, Catalyst 2820, Catalyst 2900 XL, Catalyst 2950, and Catalyst 3500 XL switches. For complete information about these switches in a switch-cluster environment, refer to the software configuration guide for that specific switch.

- Command-switch redundancy if a cluster command switch fails. One or more switches can be designated as *standby cluster command switches* to avoid loss of contact with cluster members. A *cluster standby group* is a group of standby cluster command switches.
- Management of a variety of Catalyst switches through a single IP address. This conserves on IP addresses, especially if you have a limited number of them. All communication with the switch cluster is through the cluster command switch IP address.

[Table 5-1](#) lists the Catalyst switches eligible for switch clustering, including which ones can be cluster command switches and which ones can only be cluster member switches, and the required software versions.

Table 5-1 Switch Software and Cluster Capability

Switch	Cisco IOS Release	Cluster Capability
Catalyst 3750	12.1(11)AX or later	Member or command switch
Catalyst 3560	12.1(19)EA1b or later	Member or command switch
Catalyst 3550	12.1(4)EA1 or later	Member or command switch
Catalyst 2970	12.1(11)AX or later	Member or command switch
Catalyst 2960	12.2(25)FX or later	Member or command switch
Catalyst 2955	12.1(12c)EA1 or later	Member or command switch
Catalyst 2950	12.0(5.2)WC(1) or later	Member or command switch
Catalyst 2950 LRE	12.1(11)JY or later	Member or command switch
Catalyst 2940	12.1(13)AY or later	Member or command switch
Catalyst 3500 XL	12.0(5.1)XU or later	Member or command switch
Catalyst 2900 XL (8-MB switches)	12.0(5.1)XU or later	Member or command switch
Catalyst 2900 XL (4-MB switches)	11.2(8.5)SA6 (recommended)	Member switch only
Catalyst 1900 and 2820	9.00(-A or -EN) or later	Member switch only

Cluster Command Switch Characteristics

A cluster command switch must meet these requirements:

- It is running Cisco IOS Release 12.2(25)FX or later.
- It has an IP address.
- It has Cisco Discovery Protocol (CDP) version 2 enabled (the default).
- It is not a command or cluster member switch of another cluster.
- It is connected to the standby cluster command switches through the management VLAN and to the cluster member switches through a common VLAN.

Standby Cluster Command Switch Characteristics

A standby cluster command switch must meet these requirements:

- It is running Cisco IOS 12.2(25)FX or later.
- It has an IP address.
- It has CDP version 2 enabled.
- It is connected to the command switch and to other standby command switches through its management VLAN.
- It is connected to all other cluster member switches (except the cluster command and standby command switches) through a common VLAN.
- It is redundantly connected to the cluster so that connectivity to cluster member switches is maintained.
- It is not a command or member switch of another cluster.

**Note**

Standby cluster command switches must be the same type of switches as the cluster command switch. For example, if the cluster command switch is a Catalyst switch, the standby cluster command switches must also be Catalyst switches. Refer to the switch configuration guide of other cluster-capable switches for their requirements on standby cluster command switches.

Candidate Switch and Cluster Member Switch Characteristics

Candidate switches are cluster-capable switches that have not yet been added to a cluster. Cluster member switches are switches that have actually been added to a switch cluster. Although not required, a candidate or cluster member switch can have its own IP address and password (for related considerations, see the [“IP Addresses”](#) section on page 5-12 and [“Passwords”](#) section on page 5-13).

To join a cluster, a candidate switch must meet these requirements:

- It is running cluster-capable software.
- It has CDP version 2 enabled.
- It is not a command or cluster member switch of another cluster.

- If a cluster standby group exists, it is connected to every standby cluster command switch through at least one common VLAN. The VLAN to each standby cluster command switch can be different.
- It is connected to the cluster command switch through at least one common VLAN.



Note Catalyst 1900, Catalyst 2820, Catalyst 2900 XL, Catalyst 2950, and Catalyst 3500 XL candidate and cluster member switches must be connected through their management VLAN to the cluster command switch and standby cluster command switches. For complete information about these switches in a switch-cluster environment, refer to the software configuration guide for that specific switch.

This requirement does not apply if you have a Catalyst 2970, Catalyst 3550, Catalyst 3560, or Catalyst 3750 cluster command switch. Candidate and cluster member switches can connect through any VLAN in common with the cluster command switch.

Planning a Switch Cluster

Anticipating conflicts and compatibility issues is a high priority when you manage several switches through a cluster. This section describes these guidelines, requirements, and caveats that you should understand before you create the cluster:

- [Automatic Discovery of Cluster Candidates and Members, page 5-4](#)
- [HSRP and Standby Cluster Command Switches, page 5-9](#)
- [IP Addresses, page 5-12](#)
- [Hostnames, page 5-12](#)
- [Passwords, page 5-13](#)
- [SNMP Community Strings, page 5-13](#)
- [TACACS+ and RADIUS, page 5-14](#)
- [LRE Profiles, page 5-14](#)

Refer to the release notes for the list of Catalyst switches eligible for switch clustering, including which ones can be cluster command switches and which ones can only be cluster member switches, and for the required software versions and browser and Java plug-in configurations.

Automatic Discovery of Cluster Candidates and Members

The cluster command switch uses Cisco Discovery Protocol (CDP) to discover cluster member switches, candidate switches, neighboring switch clusters, and edge devices across multiple VLANs and in star or cascaded topologies.



Note

Do not disable CDP on the cluster command switch, on cluster members, or on any cluster-capable switches that you might want a cluster command switch to discover. For more information about CDP, see [Chapter 20, “Configuring CDP.”](#)

Following these connectivity guidelines ensures automatic discovery of the switch cluster, cluster candidates, connected switch clusters, and neighboring edge devices:

- [Discovery Through CDP Hops, page 5-5](#)
- [Discovery Through Non-CDP-Capable and Noncluster-Capable Devices, page 5-6](#)
- [Discovery Through Different VLANs, page 5-6](#)
- [Discovery Through Different Management VLANs, page 5-7](#)
- [Discovery of Newly Installed Switches, page 5-8](#)

Discovery Through CDP Hops

By using CDP, a cluster command switch can discover switches up to seven CDP hops away (the default is three hops) from the edge of the cluster. The edge of the cluster is where the last cluster member switches are connected to the cluster and to candidate switches. For example, cluster member switches 9 and 10 in [Figure 5-1](#) are at the edge of the cluster.

In [Figure 5-1](#), the cluster command switch has ports assigned to VLANs 16 and 62. The CDP hop count is three. The cluster command switch discovers switches 11, 12, 13, and 14 because they are within three hops from the edge of the cluster. It does not discover switch 15 because it is four hops from the edge of the cluster.

Figure 5-1 Discovery Through CDP Hops

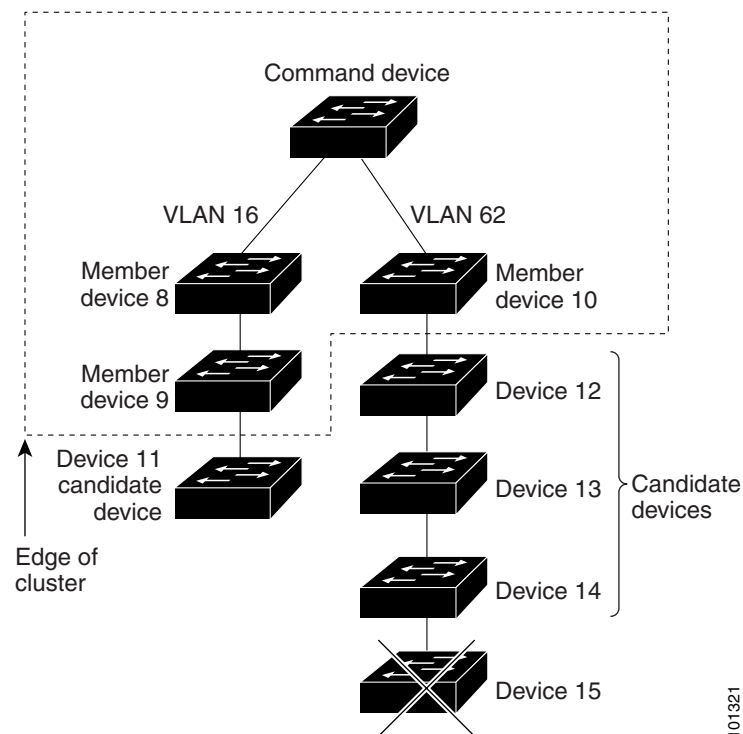

Discovery Through Non-CDP-Capable and Noncluster-Capable Devices

If a cluster command switch is connected to a *non-CDP-capable third-party hub* (such as a non-Cisco hub), it can discover cluster-enabled devices connected to that third-party hub. However, if the cluster command switch is connected to a *noncluster-capable Cisco device*, it cannot discover a cluster-enabled device connected beyond the noncluster-capable Cisco device.

Figure 5-2 shows that the cluster command switch discovers the switch that is connected to a third-party hub. However, the cluster command switch does not discover the switch that is connected to a Catalyst 5000 switch.

Figure 5-2 Discovery Through Non-CDP-Capable and Noncluster-Capable Devices

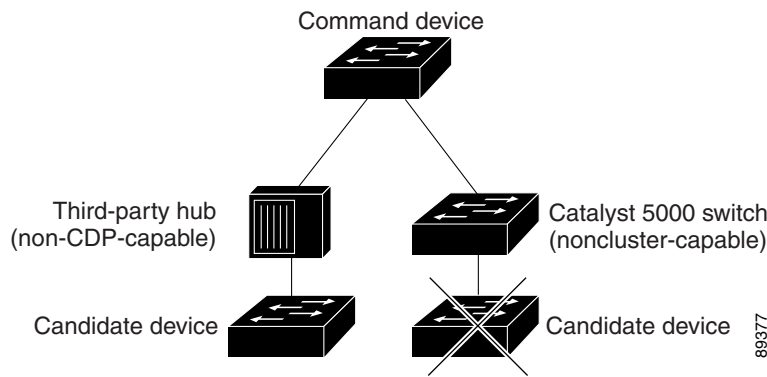

Discovery Through Different VLANs

If the cluster command switch is a Catalyst 2970, Catalyst 3550, Catalyst 3560, or Catalyst 3750 switch, the cluster can have cluster member switches in different VLANs. As cluster member switches, they must be connected through at least one VLAN in common with the cluster command switch. The cluster command switch in Figure 5-3 has ports assigned to VLANs 9, 16, and 62 and therefore discovers the switches in those VLANs. It does not discover the switch in VLAN 50. It also does not discover the switch in VLAN 16 in the first column because the cluster command switch has no VLAN connectivity to it.

Catalyst 2900 XL, Catalyst 2950, and Catalyst 3500 XL cluster member switches must be connected to the cluster command switch through their management VLAN. For information about discovery through management VLANs, see the “Discovery Through Different Management VLANs” section on page 5-7. For more information about VLANs, see Chapter 12, “Configuring VLANs.”

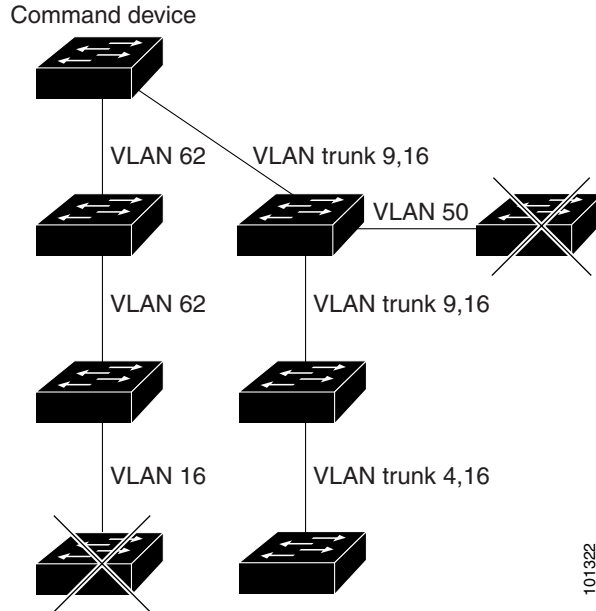
Figure 5-3 Discovery Through Different VLANs

Discovery Through Different Management VLANs

Catalyst 2970, Catalyst 3550, Catalyst 3560, or Catalyst 3750 cluster command switches can discover and manage cluster member switches in different VLANs and different management VLANs. As cluster member switches, they must be connected through at least one VLAN in common with the cluster command switch. They do not need to be connected to the cluster command switch through their management VLAN. The default management VLAN is VLAN 1.



Note

If the switch cluster has a Catalyst 3750 switch or switch stack, that switch or switch stack must be the cluster command switch.

The cluster command switch and standby command switch in [Figure 5-4](#) (assuming they are Catalyst 2960 Catalyst 2970, Catalyst 3550, Catalyst 3560, or Catalyst 3750 cluster command switches) have ports assigned to VLANs 9, 16, and 62. The management VLAN on the cluster command switch is VLAN 9. Each cluster command switch discovers the switches in the different management VLANs except these:

- Switches 7 and 10 (switches in management VLAN 4) because they are not connected through a common VLAN (meaning VLANs 62 and 9) with the cluster command switch
- Switch 9 because automatic discovery does not extend beyond a noncandidate device, which is switch 7

Figure 5-4 Discovery Through Different Management VLANs with a Layer 3 Cluster Command Switch

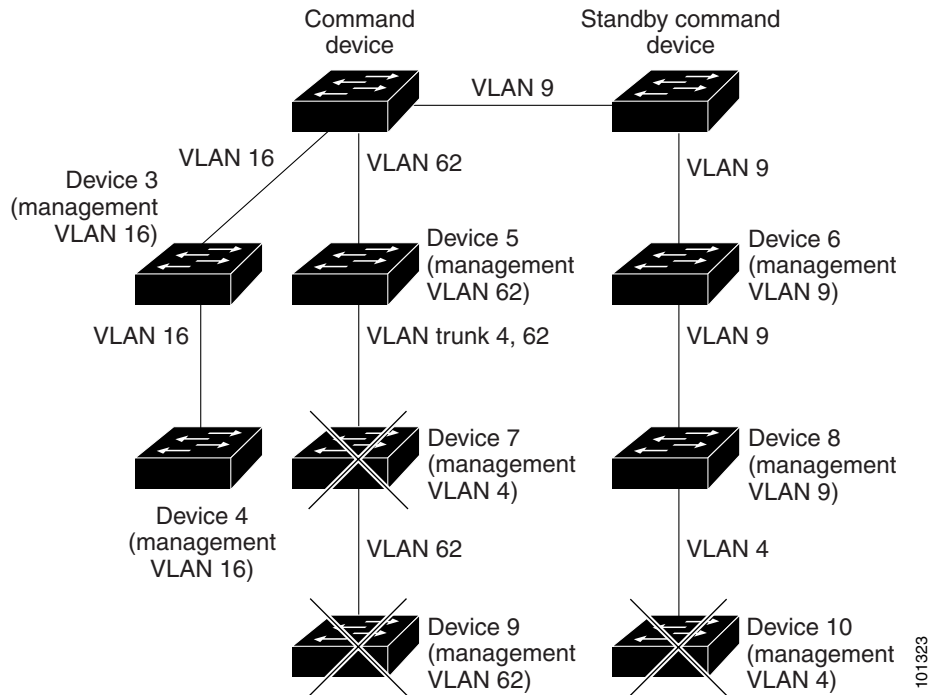

Discovery of Newly Installed Switches

To join a cluster, the new, out-of-the-box switch must be connected to the cluster through one of its access ports. An access port (AP) carries the traffic of and belongs to only one VLAN. By default, the new switch and its access ports are assigned to VLAN 1.

When the new switch joins a cluster, its default VLAN changes to the VLAN of the immediately upstream neighbor. The new switch also configures its access port to belong to the VLAN of the immediately upstream neighbor.

The cluster command switch in [Figure 5-5](#) belongs to VLANs 9 and 16. When new cluster-capable switches join the cluster:

- One cluster-capable switch and its access port are assigned to VLAN 9.
- The other cluster-capable switch and its access port are assigned to management VLAN 16.

Figure 5-5 Discovery of Newly Installed Switches

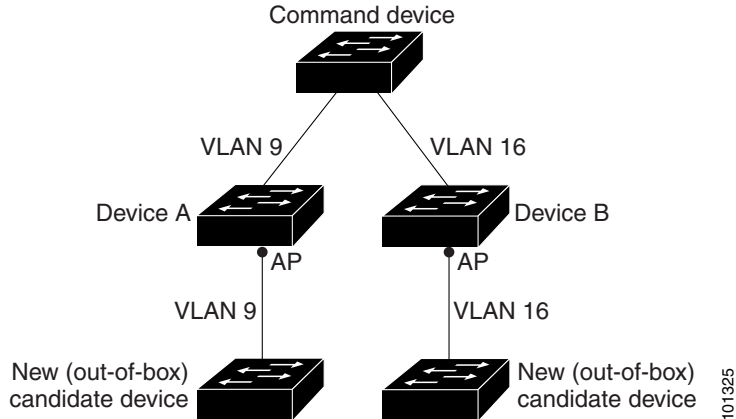

HSRP and Standby Cluster Command Switches

The switch uses Hot Standby Router Protocol (HSRP) so that you can configure a group of standby cluster command switches. Because a cluster command switch manages the forwarding of all communication and configuration information to all the cluster member switches, we strongly recommend the following:

- For a cluster command switch stack, a standby cluster command switch is necessary if the entire switch stack fails. However, if only the stack master in the command switch stack fails, the switch stack elects a new stack master and resumes its role as the cluster command switch stack.
- For a cluster command switch that is a standalone switch, configure a standby cluster command switch to take over if the primary cluster command switch fails.

A *cluster standby group* is a group of command-capable switches that meet the requirements described in the “[Standby Cluster Command Switch Characteristics](#)” section on page 5-3. Only one cluster standby group can be assigned per cluster.

The switches in the cluster standby group are ranked according to HSRP priorities. The switch with the highest priority in the group is the *active cluster command switch* (AC). The switch with the next highest priority is the *standby cluster command switch* (SC). The other switches in the cluster standby group are the *passive cluster command switches* (PC). If the active cluster command switch and the standby cluster command switch become disabled *at the same time*, the passive cluster command switch with the highest priority becomes the active cluster command switch. For the limitations to automatic discovery, see the “[Automatic Recovery of Cluster Configuration](#)” section on page 5-11.



Note

The HSRP standby hold time interval should be greater than or equal to three times the hello time interval. The default HSRP standby hold time interval is 10 seconds. The default HSRP standby hello time interval is 3 seconds.

These connectivity guidelines ensure automatic discovery of the switch cluster, cluster candidates, connected switch clusters, and neighboring edge devices. These topics also provide more detail about standby cluster command switches:

- [Virtual IP Addresses, page 5-10](#)
- [Other Considerations for Cluster Standby Groups, page 5-10](#)
- [Automatic Recovery of Cluster Configuration, page 5-11](#)

Virtual IP Addresses

You need to assign a unique virtual IP address and group number and name to the cluster standby group. This information must be configured on a specific VLAN or routed port on the active cluster command switch. The active cluster command switch receives traffic destined for the virtual IP address. To manage the cluster, you must access the active cluster command switch through the virtual IP address, not through the command-switch IP address. This is in case the IP address of the active cluster command switch is different from the virtual IP address of the cluster standby group.

If the active cluster command switch fails, the standby cluster command switch assumes ownership of the virtual IP address and becomes the active cluster command switch. The passive switches in the cluster standby group compare their assigned priorities to decide the new standby cluster command switch. The passive standby switch with the highest priority then becomes the standby cluster command switch. When the previously active cluster command switch becomes active again, it resumes its role as the active cluster command switch, and the current active cluster command switch becomes the standby cluster command switch again. For more information about IP address in switch clusters, see the [“IP Addresses” section on page 5-12](#).

Other Considerations for Cluster Standby Groups

These requirements also apply:

- Standby cluster command switches must be the same type of switches as the cluster command switch. For example, if the cluster command switch is a Catalyst 2960 switch, the standby cluster command switches must also be Catalyst 2960 switches. Refer to the switch configuration guide of other cluster-capable switches for their requirements on standby cluster command switches.
If your switch cluster has a Catalyst 2960 switch, it should be the cluster command switch.
- Only one cluster standby group can be assigned to a cluster. You can have more than one router-redundancy standby group.

- All standby-group members must be members of the cluster.



Note There is no limit to the number of switches that you can assign as standby cluster command switches. However, the total number of switches in the cluster—which would include the active cluster command switch, standby-group members, and cluster member switches—cannot be more than 16.

- Each standby-group member (Figure 5-6) must be connected to the cluster command switch through the same VLAN. In this example, the cluster command switch and standby cluster command switches are Catalyst 2970, Catalyst 3550, Catalyst 3560, or Catalyst 3750 cluster command switches. Each standby-group member must also be redundantly connected to each other through at least one VLAN in common with the switch cluster.

Catalyst 1900, Catalyst 2820, Catalyst 2900 XL, Catalyst 2950, and Catalyst 3500 XL cluster member switches must be connected to the cluster standby group through their management VLANs. For more information about VLANs in switch clusters, see these sections:

- “Discovery Through Different VLANs” section on page 5-6
- “Discovery Through Different Management VLANs” section on page 5-7

Figure 5-6 VLAN Connectivity between Standby-Group Members and Cluster Members

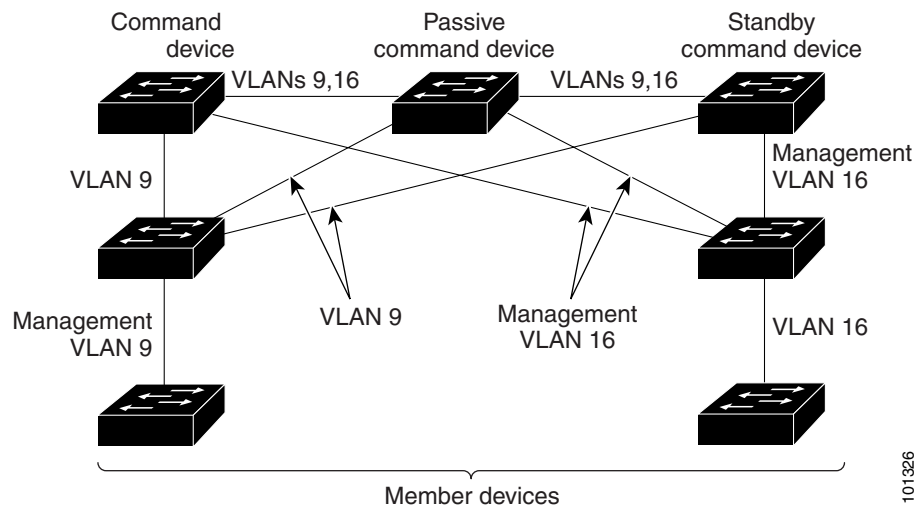

Automatic Recovery of Cluster Configuration

The active cluster command switch continually forwards cluster-configuration information (but not device-configuration information) to the standby cluster command switch. This ensures that the standby cluster command switch can take over the cluster immediately after the active cluster command switch fails.

Automatic discovery has these limitations:

- This limitation applies only to clusters that have Catalyst 2950, Catalyst 3550, Catalyst 3560, and Catalyst 3750 command and standby cluster command switches: If the active cluster command switch and standby cluster command switch become disabled *at the same time*, the passive cluster command switch with the highest priority becomes the active cluster command switch. However, because it was a passive standby cluster command switch, the previous cluster command switch *did not* forward cluster-configuration information to it. The active cluster command switch only forwards cluster-configuration information to the standby cluster command switch. You must therefore rebuild the cluster.
- This limitation applies to all clusters: If the active cluster command switch fails and there are more than two switches in the cluster standby group, the new cluster command switch does not discover any Catalyst 1900, Catalyst 2820, and Catalyst 2916M XL cluster member switches. You must re-add these cluster member switches to the cluster.
- This limitation applies to all clusters: If the active cluster command switch fails and becomes active again, it does not discover any Catalyst 1900, Catalyst 2820, and Catalyst 2916M XL cluster member switches. You must again add these cluster member switches to the cluster.

When the previously active cluster command switch resumes its active role, it receives a copy of the latest cluster configuration from the active cluster command switch, including members that were added while it was down. The active cluster command switch sends a copy of the cluster configuration to the cluster standby group.

IP Addresses

You must assign IP information to a cluster command switch. You can assign more than one IP address to the cluster command switch, and you can access the cluster through any of the command-switch IP addresses. If you configure a cluster standby group, you must use the standby-group virtual IP address to manage the cluster from the active cluster command switch. Using the virtual IP address ensures that you retain connectivity to the cluster if the active cluster command switch fails and that a standby cluster command switch becomes the active cluster command switch.

If the active cluster command switch fails and the standby cluster command switch takes over, you must either use the standby-group virtual IP address or any of the IP addresses available on the new active cluster command switch to access the cluster.

You can assign an IP address to a cluster-capable switch, but it is not necessary. A cluster member switch is managed and communicates with other cluster member switches through the command-switch IP address. If the cluster member switch leaves the cluster and it does not have its own IP address, you must assign an IP address to manage it as a standalone switch.

For more information about IP addresses, see [Chapter 3, “Assigning the Switch IP Address and Default Gateway.”](#)

Hostnames

You do not need to assign a host name to either a cluster command switch or an eligible cluster member. However, a hostname assigned to the cluster command switch can help to identify the switch cluster. The default hostname for the switch is *Switch*.

If a switch joins a cluster and it does not have a hostname, the cluster command switch appends a unique member number to its own hostname and assigns it sequentially as each switch joins the cluster. The number means the order in which the switch was added to the cluster. For example, a cluster command switch named *eng-cluster* could name the fifth cluster member *eng-cluster-5*.

If a switch has a hostname, it retains that name when it joins a cluster and when it leaves the cluster.

If a switch received its hostname from the cluster command switch, was removed from a cluster, was then added to a new cluster, and kept the same member number (such as 5), the switch overwrites the old hostname (such as *eng-cluster-5*) with the hostname of the cluster command switch in the new cluster (such as *mkg-cluster-5*). If the switch member number changes in the new cluster (such as 3), the switch retains the previous name (*eng-cluster-5*).

Passwords

You do not need to assign passwords to an individual switch if it will be a cluster member. When a switch joins a cluster, it inherits the command-switch password and retains it when it leaves the cluster. If no command-switch password is configured, the cluster member switch inherits a null password. Cluster member switches only inherit the command-switch password.

If you change the member-switch password to be different from the command-switch password and save the change, the switch is not manageable by the cluster command switch until you change the member-switch password to match the command-switch password. Rebooting the member switch does not revert the password back to the command-switch password. We recommend that you do not change the member-switch password after it joins a cluster.

For more information about passwords, see the [“Preventing Unauthorized Access to Your Switch” section on page 8-1](#).

For password considerations specific to the Catalyst 1900 and Catalyst 2820 switches, refer to the installation and configuration guides for those switches.

SNMP Community Strings

A cluster member switch inherits the command-switch first read-only (RO) and read-write (RW) community strings with *@esN* appended to the community strings:

- *command-switch-readonly-community-string@esN*, where *N* is the member-switch number.
- *command-switch-readwrite-community-string@esN*, where *N* is the member-switch number.

If the cluster command switch has multiple read-only or read-write community strings, only the first read-only and read-write strings are propagated to the cluster member switch.

The switches support an unlimited number of community strings and string lengths. For more information about SNMP and community strings, see [Chapter 26, “Configuring SNMP.”](#)

For SNMP considerations specific to the Catalyst 1900 and Catalyst 2820 switches, refer to the installation and configuration guides specific to those switches.

TACACS+ and RADIUS

If Terminal Access Controller Access Control System Plus (TACACS+) is configured on a cluster member, it must be configured on all cluster members. Similarly, if RADIUS is configured on a cluster member, it must be configured on all cluster members. Further, the same switch cluster cannot have some members configured with TACACS+ and other members configured with RADIUS.

For more information about TACACS+, see the [“Controlling Switch Access with TACACS+”](#) section on page 8-10. For more information about RADIUS, see the [“Controlling Switch Access with RADIUS”](#) section on page 8-17.

LRE Profiles

A configuration conflict occurs if a switch cluster has Long-Reach Ethernet (LRE) switches that use both private and public profiles. If one LRE switch in a cluster is assigned a public profile, all LRE switches in that cluster must have that same public profile. Before you add an LRE switch to a cluster, make sure that you assign it the same public profile used by other LRE switches in the cluster.

A cluster can have a mix of LRE switches that use different private profiles.

Using the CLI to Manage Switch Clusters

You can configure cluster member switches from the CLI by first logging into the cluster command switch. Enter the **rcommand** user EXEC command and the cluster member switch number to start a Telnet session (through a console or Telnet connection) and to access the cluster member switch CLI. The command mode changes, and the Cisco IOS commands operate as usual. Enter the **exit** privileged EXEC command on the cluster member switch to return to the command-switch CLI.

This example shows how to log into member-switch 3 from the command-switch CLI:

```
switch# rcommand 3
```

If you do not know the member-switch number, enter the **show cluster members** privileged EXEC command on the cluster command switch. For more information about the **rcommand** command and all other cluster commands, refer to the switch command reference.

The Telnet session accesses the member-switch CLI at the same privilege level as on the cluster command switch. The Cisco IOS commands then operate as usual. For instructions on configuring the switch for a Telnet session, see the [“Disabling Password Recovery”](#) section on page 8-5.

Catalyst 1900 and Catalyst 2820 CLI Considerations

If your switch cluster has Catalyst 1900 and Catalyst 2820 switches running standard edition software, the Telnet session accesses the management console (a menu-driven interface) if the cluster command switch is at privilege level 15. If the cluster command switch is at privilege level 1 to 14, you are prompted for the password to access the menu console.

Command-switch privilege levels map to the Catalyst 1900 and Catalyst 2820 cluster member switches running standard and Enterprise Edition Software as follows:

- If the command-switch privilege level is 1 to 14, the cluster member switch is accessed at privilege level 1.
- If the command-switch privilege level is 15, the cluster member switch is accessed at privilege level 15.



Note The Catalyst 1900 and Catalyst 2820 CLI is available only on switches running Enterprise Edition Software.

For more information about the Catalyst 1900 and Catalyst 2820 switches, refer to the installation and configuration guides for those switches.

Using SNMP to Manage Switch Clusters

When you first power on the switch, SNMP is enabled if you enter the IP information by using the setup program and accept its proposed configuration. If you did not use the setup program to enter the IP information and SNMP was not enabled, you can enable it as described in the [“Configuring SNMP” section on page 26-6](#). On Catalyst 1900 and Catalyst 2820 switches, SNMP is enabled by default.

When you create a cluster, the cluster command switch manages the exchange of messages between cluster member switches and an SNMP application. The cluster software on the cluster command switch appends the cluster member switch number (*@esN*, where *N* is the switch number) to the first configured read-write and read-only community strings on the cluster command switch and propagates them to the cluster member switch. The cluster command switch uses this community string to control the forwarding of gets, sets, and get-next messages between the SNMP management station and the cluster member switches.



Note When a cluster standby group is configured, the cluster command switch can change without your knowledge. Use the first read-write and read-only community strings to communicate with the cluster command switch if there is a cluster standby group configured for the cluster.

If the cluster member switch does not have an IP address, the cluster command switch redirects traps from the cluster member switch to the management station, as shown in [Figure 5-7](#). If a cluster member switch has its own IP address and community strings, the cluster member switch can send traps directly to the management station, without going through the cluster command switch.

If a cluster member switch has its own IP address and community strings, they can be used in addition to the access provided by the cluster command switch. For more information about SNMP and community strings, see [Chapter 26, “Configuring SNMP.”](#)

Figure 5-7 *SNMP Management for a Cluster*

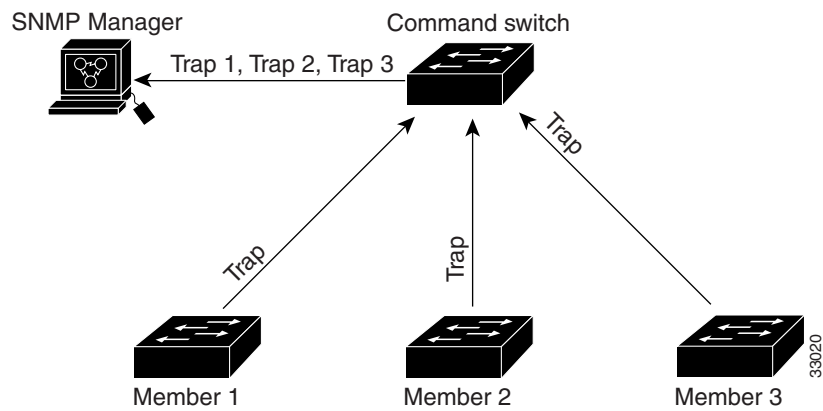



CHAPTER 6

Administering the Switch

This chapter describes how to perform one-time operations to administer the Catalyst 2960 switch.

This chapter consists of these sections:

- [Managing the System Time and Date, page 6-1](#)
- [Configuring a System Name and Prompt, page 6-14](#)
- [Creating a Banner, page 6-17](#)
- [Managing the MAC Address Table, page 6-19](#)
- [Managing the ARP Table, page 6-26](#)

Managing the System Time and Date

You can manage the system time and date on your switch using automatic configuration, such as the Network Time Protocol (NTP), or manual configuration methods.



Note

For complete syntax and usage information for the commands used in this section, see the *Cisco IOS Configuration Fundamentals Command Reference* from the Cisco.com page under **Documentation > Cisco IOS Software > 12.2 Mainline > Command References**.

These sections contain this configuration information:

- [Understanding the System Clock, page 6-1](#)
- [Understanding Network Time Protocol, page 6-2](#)
- [Configuring NTP, page 6-3](#)
- [Configuring Time and Date Manually, page 6-11](#)

Understanding the System Clock

The heart of the time service is the system clock. This clock runs from the moment the system starts up and keeps track of the date and time.

The system clock can then be set from these sources:

- NTP
- Manual configuration

The system clock can provide time to these services:

- User **show** commands
- Logging and debugging messages

The system clock keeps track of time internally based on Universal Time Coordinated (UTC), also known as Greenwich Mean Time (GMT). You can configure information about the local time zone and summer time (daylight saving time) so that the time appears correctly for the local time zone.

The system clock keeps track of whether the time is *authoritative* or not (that is, whether it has been set by a time source considered to be authoritative). If it is not authoritative, the time is available only for display purposes and is not redistributed. For configuration information, see the “[Configuring Time and Date Manually](#)” section on page 6-11.

Understanding Network Time Protocol

The NTP is designed to time-synchronize a network of devices. NTP runs over User Datagram Protocol (UDP), which runs over IP. NTP is documented in RFC 1305.

An NTP network usually gets its time from an authoritative time source, such as a radio clock or an atomic clock attached to a time server. NTP then distributes this time across the network. NTP is extremely efficient; no more than one packet per minute is necessary to synchronize two devices to within a millisecond of one another.

NTP uses the concept of a *stratum* to describe how many NTP hops away a device is from an authoritative time source. A stratum 1 time server has a radio or atomic clock directly attached, a stratum 2 time server receives its time through NTP from a stratum 1 time server, and so on. A device running NTP automatically chooses as its time source the device with the lowest stratum number with which it communicates through NTP. This strategy effectively builds a self-organizing tree of NTP speakers.

NTP avoids synchronizing to a device whose time might not be accurate by never synchronizing to a device that is not synchronized. NTP also compares the time reported by several devices and does not synchronize to a device whose time is significantly different than the others, even if its stratum is lower.

The communications between devices running NTP (known as *associations*) are usually statically configured; each device is given the IP address of all devices with which it should form associations. Accurate timekeeping is possible by exchanging NTP messages between each pair of devices with an association. However, in a LAN environment, NTP can be configured to use IP broadcast messages instead. This alternative reduces configuration complexity because each device can simply be configured to send or receive broadcast messages. However, in that case, information flow is one-way only.

The time kept on a device is a critical resource; you should use the security features of NTP to avoid the accidental or malicious setting of an incorrect time. Two mechanisms are available: an access list-based restriction scheme and an encrypted authentication mechanism.

Cisco’s implementation of NTP does not support stratum 1 service; it is not possible to connect to a radio or atomic clock. We recommend that the time service for your network be derived from the public NTP servers available on the IP Internet.

Figure 6-1 shows a typical network example using NTP. Switch A is the NTP master, with Switches B, C, and D configured in NTP server mode, in server association with Switch A. Switch E is configured as an NTP peer to the upstream and downstream switches, Switch B and Switch F.

Figure 6-1 Typical NTP Network Configuration

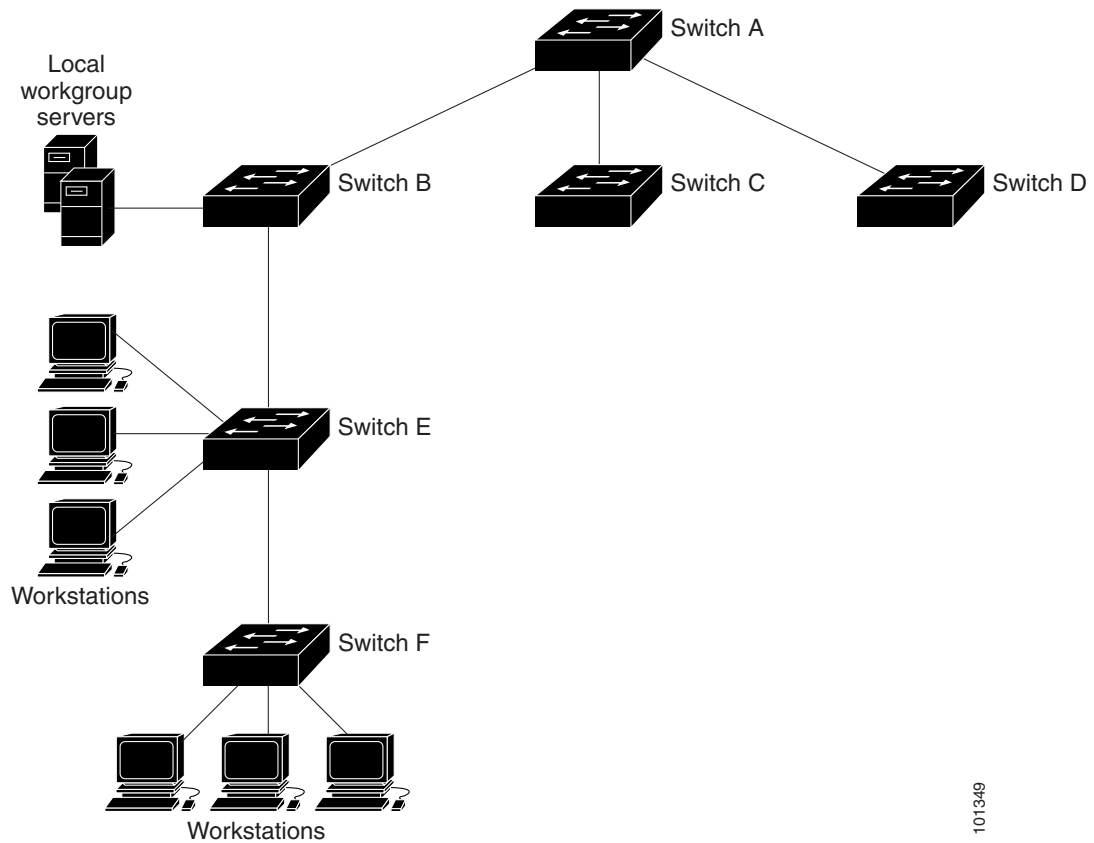

101349

If the network is isolated from the Internet, Cisco's implementation of NTP allows a device to act as if it is synchronized through NTP, when in fact it has learned the time by using other means. Other devices then synchronize to that device through NTP.

When multiple sources of time are available, NTP is always considered to be more authoritative. NTP time overrides the time set by any other method.

Several manufacturers include NTP software for their host systems, and a publicly available version for systems running UNIX and its various derivatives is also available. This software allows host systems to be time-synchronized as well.

Configuring NTP

The switch does not have a hardware-supported clock and cannot function as an NTP master clock to which peers synchronize themselves when an external NTP source is not available. The switch also has no hardware support for a calendar. As a result, the `ntp update-calendar` and the `ntp master` global configuration commands are not available.

These sections contain this configuration information:

- [Default NTP Configuration, page 6-4](#)
- [Configuring NTP Authentication, page 6-4](#)
- [Configuring NTP Associations, page 6-5](#)
- [Configuring NTP Broadcast Service, page 6-6](#)
- [Configuring NTP Access Restrictions, page 6-8](#)
- [Configuring the Source IP Address for NTP Packets, page 6-10](#)
- [Displaying the NTP Configuration, page 6-11](#)

Default NTP Configuration

Table 6-1 shows the default NTP configuration.

Table 6-1 *Default NTP Configuration*

Feature	Default Setting
NTP authentication	Disabled. No authentication key is specified.
NTP peer or server associations	None configured.
NTP broadcast service	Disabled; no interface sends or receives NTP broadcast packets.
NTP access restrictions	No access control is specified.
NTP packet source IP address	The source address is set by the outgoing interface.

NTP is enabled on all interfaces by default. All interfaces receive NTP packets.

Configuring NTP Authentication

This procedure must be coordinated with the administrator of the NTP server; the information you configure in this procedure must be matched by the servers used by the switch to synchronize its time to the NTP server.

Beginning in privileged EXEC mode, follow these steps to authenticate the associations (communications between devices running NTP that provide for accurate timekeeping) with other devices for security purposes:

	Command	Purpose
Step 1	configure terminal	Enter global configuration mode.
Step 2	ntp authenticate	Enable the NTP authentication feature, which is disabled by default.

	Command	Purpose
Step 3	ntp authentication-key <i>number</i> md5 <i>value</i>	<p>Define the authentication keys. By default, none are defined.</p> <ul style="list-style-type: none"> For <i>number</i>, specify a key number. The range is 1 to 4294967295. md5 specifies that message authentication support is provided by using the message digest algorithm 5 (MD5). For <i>value</i>, enter an arbitrary string of up to eight characters for the key. <p>The switch does not synchronize to a device unless both have one of these authentication keys, and the key number is specified by the ntp trusted-key <i>key-number</i> command.</p>
Step 4	ntp trusted-key <i>key-number</i>	<p>Specify one or more key numbers (defined in Step 3) that a peer NTP device must provide in its NTP packets for this switch to synchronize to it.</p> <p>By default, no trusted keys are defined.</p> <p>For <i>key-number</i>, specify the key defined in Step 3.</p> <p>This command provides protection against accidentally synchronizing the switch to a device that is not trusted.</p>
Step 5	end	Return to privileged EXEC mode.
Step 6	show running-config	Verify your entries.
Step 7	copy running-config startup-config	(Optional) Save your entries in the configuration file.

To disable NTP authentication, use the **no ntp authenticate** global configuration command. To remove an authentication key, use the **no ntp authentication-key** *number* global configuration command. To disable authentication of the identity of a device, use the **no ntp trusted-key** *key-number* global configuration command.

This example shows how to configure the switch to synchronize only to devices providing authentication key 42 in the device's NTP packets:

```
Switch(config)# ntp authenticate
Switch(config)# ntp authentication-key 42 md5 aNiceKey
Switch(config)# ntp trusted-key 42
```

Configuring NTP Associations

An NTP association can be a peer association (this switch can either synchronize to the other device or allow the other device to synchronize to it), or it can be a server association (meaning that only this switch synchronizes to the other device, and not the other way around).

Beginning in privileged EXEC mode, follow these steps to form an NTP association with another device:

	Command	Purpose
Step 1	configure terminal	Enter global configuration mode.
Step 2	ntp peer <i>ip-address</i> [version <i>number</i>] [key <i>keyid</i>] [source <i>interface</i>] [prefer] or ntp server <i>ip-address</i> [version <i>number</i>] [key <i>keyid</i>] [source <i>interface</i>] [prefer]	Configure the switch system clock to synchronize a peer or to be synchronized by a peer (peer association). or Configure the switch system clock to be synchronized by a time server (server association). No peer or server associations are defined by default. <ul style="list-style-type: none"> For <i>ip-address</i> in a peer association, specify either the IP address of the peer providing, or being provided, the clock synchronization. For a server association, specify the IP address of the time server providing the clock synchronization. (Optional) For <i>number</i>, specify the NTP version number. The range is 1 to 3. By default, Version 3 is selected. (Optional) For <i>keyid</i>, enter the authentication key defined with the ntp authentication-key global configuration command. (Optional) For <i>interface</i>, specify the interface from which to pick the IP source address. By default, the source IP address is taken from the outgoing interface. (Optional) Enter the prefer keyword to make this peer or server the preferred one that provides synchronization. This keyword reduces switching back and forth between peers and servers.
Step 3	end	Return to privileged EXEC mode.
Step 4	show running-config	Verify your entries.
Step 5	copy running-config startup-config	(Optional) Save your entries in the configuration file.

You need to configure only one end of an association; the other device can automatically establish the association. If you are using the default NTP version (Version 3) and NTP synchronization does not occur, try using NTP Version 2. Many NTP servers on the Internet run Version 2.

To remove a peer or server association, use the **no ntp peer** *ip-address* or the **no ntp server** *ip-address* global configuration command.

This example shows how to configure the switch to synchronize its system clock with the clock of the peer at IP address 172.16.22.44 using NTP Version 2:

```
Switch(config)# ntp server 172.16.22.44 version 2
```

Configuring NTP Broadcast Service

The communications between devices running NTP (known as *associations*) are usually statically configured; each device is given the IP addresses of all devices with which it should form associations. Accurate timekeeping is possible by exchanging NTP messages between each pair of devices with an association. However, in a LAN environment, NTP can be configured to use IP broadcast messages instead. This alternative reduces configuration complexity because each device can simply be configured to send or receive broadcast messages. However, the information flow is one-way only.

The switch can send or receive NTP broadcast packets on an interface-by-interface basis if there is an NTP broadcast server, such as a router, broadcasting time information on the network. The switch can send NTP broadcast packets to a peer so that the peer can synchronize to it. The switch can also receive NTP broadcast packets to synchronize its own clock. This section provides procedures for both sending and receiving NTP broadcast packets.

Beginning in privileged EXEC mode, follow these steps to configure the switch to send NTP broadcast packets to peers so that they can synchronize their clock to the switch:

	Command	Purpose
Step 1	configure terminal	Enter global configuration mode.
Step 2	interface <i>interface-id</i>	Specify the interface to send NTP broadcast packets, and enter interface configuration mode.
Step 3	ntp broadcast [version <i>number</i>] [key <i>keyid</i>] [<i>destination-address</i>]	Enable the interface to send NTP broadcast packets to a peer. By default, this feature is disabled on all interfaces. <ul style="list-style-type: none"> (Optional) For <i>number</i>, specify the NTP version number. The range is 1 to 3. If you do not specify a version, Version 3 is used. (Optional) For <i>keyid</i>, specify the authentication key to use when sending packets to the peer. (Optional) For <i>destination-address</i>, specify the IP address of the peer that is synchronizing its clock to this switch.
Step 4	end	Return to privileged EXEC mode.
Step 5	show running-config	Verify your entries.
Step 6	copy running-config startup-config	(Optional) Save your entries in the configuration file.
Step 7		Configure the connected peers to receive NTP broadcast packets as described in the next procedure.

To disable the interface from sending NTP broadcast packets, use the **no ntp broadcast** interface configuration command.

This example shows how to configure a port to send NTP Version 2 packets:

```
Switch(config)# interface gigabitethernet0/1
Switch(config-if)# ntp broadcast version 2
```

Beginning in privileged EXEC mode, follow these steps to configure the switch to receive NTP broadcast packets from connected peers:

	Command	Purpose
Step 1	configure terminal	Enter global configuration mode.
Step 2	interface <i>interface-id</i>	Specify the interface to receive NTP broadcast packets, and enter interface configuration mode.
Step 3	ntp broadcast client	Enable the interface to receive NTP broadcast packets. By default, no interfaces receive NTP broadcast packets.
Step 4	exit	Return to global configuration mode.

	Command	Purpose
Step 5	<code>ntp broadcastdelay <i>microseconds</i></code>	(Optional) Change the estimated round-trip delay between the switch and the NTP broadcast server. The default is 3000 microseconds; the range is 1 to 999999.
Step 6	<code>end</code>	Return to privileged EXEC mode.
Step 7	<code>show running-config</code>	Verify your entries.
Step 8	<code>copy running-config startup-config</code>	(Optional) Save your entries in the configuration file.

To disable an interface from receiving NTP broadcast packets, use the **no ntp broadcast client** interface configuration command. To change the estimated round-trip delay to the default, use the **no ntp broadcastdelay** global configuration command.

This example shows how to configure a port to receive NTP broadcast packets:

```
Switch(config)# interface gigabitethernet0/1
Switch(config-if)# ntp broadcast client
```

Configuring NTP Access Restrictions

You can control NTP access on two levels as described in these sections:

- [Creating an Access Group and Assigning a Basic IP Access List, page 6-8](#)
- [Disabling NTP Services on a Specific Interface, page 6-10](#)

Creating an Access Group and Assigning a Basic IP Access List

Beginning in privileged EXEC mode, follow these steps to control access to NTP services by using access lists:

	Command	Purpose
Step 1	<code>configure terminal</code>	Enter global configuration mode.
Step 2	<code>ntp access-group { query-only serve-only serve peer } <i>access-list-number</i></code>	Create an access group, and apply a basic IP access list. The keywords have these meanings: <ul style="list-style-type: none"> • query-only—Allows only NTP control queries. • serve-only—Allows only time requests. • serve—Allows time requests and NTP control queries, but does not allow the switch to synchronize to the remote device. • peer—Allows time requests and NTP control queries and allows the switch to synchronize to the remote device. For <i>access-list-number</i> , enter a standard IP access list number from 1 to 99.

	Command	Purpose
Step 3	access-list <i>access-list-number</i> permit <i>source</i> [<i>source-wildcard</i>]	<p>Create the access list.</p> <ul style="list-style-type: none"> For <i>access-list-number</i>, enter the number specified in Step 2. Enter the permit keyword to permit access if the conditions are matched. For <i>source</i>, enter the IP address of the device that is permitted access to the switch. (Optional) For <i>source-wildcard</i>, enter the wildcard bits to be applied to the source. <p>Note When creating an access list, remember that, by default, the end of the access list contains an implicit deny statement for everything if it did not find a match before reaching the end.</p>
Step 4	end	Return to privileged EXEC mode.
Step 5	show running-config	Verify your entries.
Step 6	copy running-config startup-config	(Optional) Save your entries in the configuration file.

The access group keywords are scanned in this order, from least restrictive to most restrictive:

- peer**—Allows time requests and NTP control queries and allows the switch to synchronize itself to a device whose address passes the access list criteria.
- serve**—Allows time requests and NTP control queries, but does not allow the switch to synchronize itself to a device whose address passes the access list criteria.
- serve-only**—Allows only time requests from a device whose address passes the access list criteria.
- query-only**—Allows only NTP control queries from a device whose address passes the access list criteria.

If the source IP address matches the access lists for more than one access type, the first type is granted. If no access groups are specified, all access types are granted to all devices. If any access groups are specified, only the specified access types are granted.

To remove access control to the switch NTP services, use the **no ntp access-group {query-only | serve-only | serve | peer}** global configuration command.

This example shows how to configure the switch to allow itself to synchronize to a peer from access list 99. However, the switch restricts access to allow only time requests from access list 42:

```
Switch# configure terminal
Switch(config)# ntp access-group peer 99
Switch(config)# ntp access-group serve-only 42
Switch(config)# access-list 99 permit 172.20.130.5
Switch(config)# access list 42 permit 172.20.130.6
```

Disabling NTP Services on a Specific Interface

NTP services are enabled on all interfaces by default.

Beginning in privileged EXEC mode, follow these steps to disable NTP packets from being received on an interface:

	Command	Purpose
Step 1	configure terminal	Enter global configuration mode.
Step 2	interface <i>interface-id</i>	Enter interface configuration mode, and specify the interface to disable.
Step 3	ntp disable	Disable NTP packets from being received on the interface. By default, all interfaces receive NTP packets.
Step 4	end	Return to privileged EXEC mode.
Step 5	show running-config	Verify your entries.
Step 6	copy running-config startup-config	(Optional) Save your entries in the configuration file.

To re-enable receipt of NTP packets on an interface, use the **no ntp disable** interface configuration command.

Configuring the Source IP Address for NTP Packets

When the switch sends an NTP packet, the source IP address is normally set to the address of the interface through which the NTP packet is sent. Use the **ntp source** global configuration command when you want to use a particular source IP address for all NTP packets. The address is taken from the specified interface. This command is useful if the address on an interface cannot be used as the destination for reply packets.

Beginning in privileged EXEC mode, follow these steps to configure a specific interface from which the IP source address is to be taken:

	Command	Purpose
Step 1	configure terminal	Enter global configuration mode.
Step 2	ntp source <i>type number</i>	Specify the interface type and number from which the IP source address is taken. By default, the source address is set by the outgoing interface.
Step 3	end	Return to privileged EXEC mode.
Step 4	show running-config	Verify your entries.
Step 5	copy running-config startup-config	(Optional) Save your entries in the configuration file.

The specified interface is used for the source address for all packets sent to all destinations. If a source address is to be used for a specific association, use the **source** keyword in the **ntp peer** or **ntp server** global configuration command as described in the [“Configuring NTP Associations”](#) section on page 6-5.

Displaying the NTP Configuration

You can use two privileged EXEC commands to display NTP information:

- `show ntp associations [detail]`
- `show ntp status`



Note

For detailed information about the fields in these displays, see the *Cisco IOS Configuration Fundamentals Command Reference, Release 12.2* from the Cisco.com page under **Documentation > Cisco IOS Software > 12.2 Mainline > Command References**.

Configuring Time and Date Manually

If no other source of time is available, you can manually configure the time and date after the system is restarted. The time remains accurate until the next system restart. We recommend that you use manual configuration only as a last resort. If you have an outside source to which the switch can synchronize, you do not need to manually set the system clock.

These sections contain this configuration information:

- [Setting the System Clock, page 6-11](#)
- [Displaying the Time and Date Configuration, page 6-12](#)
- [Configuring the Time Zone, page 6-12](#)
- [Configuring Summer Time \(Daylight Saving Time\), page 6-13](#)

Setting the System Clock

If you have an outside source on the network that provides time services, such as an NTP server, you do not need to manually set the system clock.

Beginning in privileged EXEC mode, follow these steps to set the system clock:

	Command	Purpose
Step 1	<code>clock set hh:mm:ss day month year</code> or <code>clock set hh:mm:ss month day year</code>	Manually set the system clock using one of these formats. <ul style="list-style-type: none"> • For <i>hh:mm:ss</i>, specify the time in hours (24-hour format), minutes, and seconds. The time specified is relative to the configured time zone. • For <i>day</i>, specify the day by date in the month. • For <i>month</i>, specify the month by name. • For <i>year</i>, specify the year (no abbreviation).

This example shows how to manually set the system clock to 1:32 p.m. on July 23, 2001:

```
Switch# clock set 13:32:00 23 July 2001
```

Displaying the Time and Date Configuration

To display the time and date configuration, use the **show clock [detail]** privileged EXEC command.

The system clock keeps an *authoritative* flag that shows whether the time is authoritative (believed to be accurate). If the system clock has been set by a timing source such as NTP, the flag is set. If the time is not authoritative, it is used only for display purposes. Until the clock is authoritative and the *authoritative* flag is set, the flag prevents peers from synchronizing to the clock when the peers' time is invalid.

The symbol that precedes the **show clock** display has this meaning:

- *—Time is not authoritative.
- (blank)—Time is authoritative.
- .—Time is authoritative, but NTP is not synchronized.

Configuring the Time Zone

Beginning in privileged EXEC mode, follow these steps to manually configure the time zone:

	Command	Purpose
Step 1	configure terminal	Enter global configuration mode.
Step 2	clock timezone <i>zone hours-offset</i> [<i>minutes-offset</i>]	Set the time zone. The switch keeps internal time in universal time coordinated (UTC), so this command is used only for display purposes and when the time is manually set. <ul style="list-style-type: none"> • For <i>zone</i>, enter the name of the time zone to be displayed when standard time is in effect. The default is UTC. • For <i>hours-offset</i>, enter the hours offset from UTC. • (Optional) For <i>minutes-offset</i>, enter the minutes offset from UTC.
Step 3	end	Return to privileged EXEC mode.
Step 4	show running-config	Verify your entries.
Step 5	copy running-config startup-config	(Optional) Save your entries in the configuration file.

The *minutes-offset* variable in the **clock timezone** global configuration command is available for those cases where a local time zone is a percentage of an hour different from UTC. For example, the time zone for some sections of Atlantic Canada (AST) is UTC-3.5, where the 3 means 3 hours and .5 means 50 percent. In this case, the necessary command is **clock timezone AST -3 30**.

To set the time to UTC, use the **no clock timezone** global configuration command.

Configuring Summer Time (Daylight Saving Time)

Beginning in privileged EXEC mode, follow these steps to configure summer time (daylight saving time) in areas where it starts and ends on a particular day of the week each year:

	Command	Purpose
Step 1	configure terminal	Enter global configuration mode.
Step 2	clock summer-time zone recurring [<i>week day month hh:mm week day month hh:mm [offset]</i>]	Configure summer time to start and end on the specified days every year. Summer time is disabled by default. If you specify clock summer-time zone recurring without parameters, the summer time rules default to the United States rules. <ul style="list-style-type: none"> For <i>zone</i>, specify the name of the time zone (for example, PDT) to be displayed when summer time is in effect. (Optional) For <i>week</i>, specify the week of the month (1 to 5 or last). (Optional) For <i>day</i>, specify the day of the week (Sunday, Monday...). (Optional) For <i>month</i>, specify the month (January, February...). (Optional) For <i>hh:mm</i>, specify the time (24-hour format) in hours and minutes. (Optional) For <i>offset</i>, specify the number of minutes to add during summer time. The default is 60.
Step 3	end	Return to privileged EXEC mode.
Step 4	show running-config	Verify your entries.
Step 5	copy running-config startup-config	(Optional) Save your entries in the configuration file.

The first part of the **clock summer-time** global configuration command specifies when summer time begins, and the second part specifies when it ends. All times are relative to the local time zone. The start time is relative to standard time. The end time is relative to summer time. If the starting month is after the ending month, the system assumes that you are in the southern hemisphere.

This example shows how to specify that summer time starts on the first Sunday in April at 02:00 and ends on the last Sunday in October at 02:00:

```
Switch(config)# clock summer-time PDT recurring 1 Sunday April 2:00 last Sunday October 2:00
```

Beginning in privileged EXEC mode, follow these steps if summer time in your area does not follow a recurring pattern (configure the exact date and time of the next summer time events):

	Command	Purpose
Step 1	configure terminal	Enter global configuration mode.
Step 2	clock summer-time zone date [month date year hh:mm month date year hh:mm [offset]] or clock summer-time zone date [date month year hh:mm date month year hh:mm [offset]]	Configure summer time to start on the first date and end on the second date. Summer time is disabled by default. <ul style="list-style-type: none"> For <i>zone</i>, specify the name of the time zone (for example, PDT) to be displayed when summer time is in effect. (Optional) For <i>week</i>, specify the week of the month (1 to 5 or last). (Optional) For <i>day</i>, specify the day of the week (Sunday, Monday...). (Optional) For <i>month</i>, specify the month (January, February...). (Optional) For <i>hh:mm</i>, specify the time (24-hour format) in hours and minutes. (Optional) For <i>offset</i>, specify the number of minutes to add during summer time. The default is 60.
Step 3	end	Return to privileged EXEC mode.
Step 4	show running-config	Verify your entries.
Step 5	copy running-config startup-config	(Optional) Save your entries in the configuration file.

The first part of the **clock summer-time** global configuration command specifies when summer time begins, and the second part specifies when it ends. All times are relative to the local time zone. The start time is relative to standard time. The end time is relative to summer time. If the starting month is after the ending month, the system assumes that you are in the southern hemisphere.

To disable summer time, use the **no clock summer-time** global configuration command.

This example shows how to set summer time to start on October 12, 2000, at 02:00, and end on April 26, 2001, at 02:00:

```
Switch(config)# clock summer-time pdt date 12 October 2000 2:00 26 April 2001 2:00
```

Configuring a System Name and Prompt

You configure the system name on the switch to identify it. By default, the system name and prompt are *Switch*.

If you have not configured a system prompt, the first 20 characters of the system name are used as the system prompt. A greater-than symbol [>] is appended. The prompt is updated whenever the system name changes.

For complete syntax and usage information for the commands used in this section, from the Cisco.com page, select **Documentation > Cisco IOS Software > 12.2 Mainline > Command References** and see the *Cisco IOS Configuration Fundamentals Command Reference* and the *Cisco IOS IP Command Reference, Volume 2 of 3: Routing Protocols*.

These sections contain this configuration information:

- [Default System Name and Prompt Configuration, page 6-15](#)
- [Configuring a System Name, page 6-15](#)
- [Understanding DNS, page 6-15](#)

Default System Name and Prompt Configuration

The default switch system name and prompt is *Switch*.

Configuring a System Name

Beginning in privileged EXEC mode, follow these steps to manually configure a system name:

	Command	Purpose
Step 1	<code>configure terminal</code>	Enter global configuration mode.
Step 2	<code>hostname <i>name</i></code>	Manually configure a system name. The default setting is <i>switch</i> . The name must follow the rules for ARPANET hostnames. They must start with a letter, end with a letter or digit, and have as interior characters only letters, digits, and hyphens. Names can be up to 63 characters.
Step 3	<code>end</code>	Return to privileged EXEC mode.
Step 4	<code>show running-config</code>	Verify your entries.
Step 5	<code>copy running-config startup-config</code>	(Optional) Save your entries in the configuration file.

When you set the system name, it is also used as the system prompt.

To return to the default hostname, use the **no hostname** global configuration command.

Understanding DNS

The DNS protocol controls the Domain Name System (DNS), a distributed database with which you can map hostnames to IP addresses. When you configure DNS on your switch, you can substitute the hostname for the IP address with all IP commands, such as **ping**, **telnet**, **connect**, and related Telnet support operations.

IP defines a hierarchical naming scheme that allows a device to be identified by its location or domain. Domain names are pieced together with periods (.) as the delimiting characters. For example, Cisco Systems is a commercial organization that IP identifies by a *com* domain name, so its domain name is *cisco.com*. A specific device in this domain, for example, the File Transfer Protocol (FTP) system is identified as *ftp.cisco.com*.

To keep track of domain names, IP has defined the concept of a domain name server, which holds a cache (or database) of names mapped to IP addresses. To map domain names to IP addresses, you must first identify the hostnames, specify the name server that is present on your network, and enable the DNS.

These sections contain this configuration information:

- [Default DNS Configuration, page 6-16](#)
- [Setting Up DNS, page 6-16](#)
- [Displaying the DNS Configuration, page 6-17](#)

Default DNS Configuration

Table 6-2 shows the default DNS configuration.

Table 6-2 Default DNS Configuration

Feature	Default Setting
DNS enable state	Enabled.
DNS default domain name	None configured.
DNS servers	No name server addresses are configured.

Setting Up DNS

Beginning in privileged EXEC mode, follow these steps to set up your switch to use the DNS:

	Command	Purpose
Step 1	configure terminal	Enter global configuration mode.
Step 2	ip domain-name <i>name</i>	Define a default domain name that the software uses to complete unqualified hostnames (names without a dotted-decimal domain name). Do not include the initial period that separates an unqualified name from the domain name. At boot-up time, no domain name is configured; however, if the switch configuration comes from a BOOTP or Dynamic Host Configuration Protocol (DHCP) server, then the default domain name might be set by the BOOTP or DHCP server (if the servers were configured with this information).
Step 3	ip name-server <i>server-address1</i> [<i>server-address2</i> ... <i>server-address6</i>]	Specify the address of one or more name servers to use for name and address resolution. You can specify up to six name servers. Separate each server address with a space. The first server specified is the primary server. The switch sends DNS queries to the primary server first. If that query fails, the backup servers are queried.
Step 4	ip domain-lookup	(Optional) Enable DNS-based hostname-to-address translation on your switch. This feature is enabled by default. If your network devices require connectivity with devices in networks for which you do not control name assignment, you can dynamically assign device names that uniquely identify your devices by using the global Internet naming scheme (DNS).
Step 5	end	Return to privileged EXEC mode.

	Command	Purpose
Step 6	<code>show running-config</code>	Verify your entries.
Step 7	<code>copy running-config startup-config</code>	(Optional) Save your entries in the configuration file.

If you use the switch IP address as its hostname, the IP address is used and no DNS query occurs. If you configure a hostname that contains no periods (`.`), a period followed by the default domain name is appended to the hostname before the DNS query is made to map the name to an IP address. The default domain name is the value set by the **ip domain-name** global configuration command. If there is a period (`.`) in the hostname, the Cisco IOS software looks up the IP address without appending any default domain name to the hostname.

To remove a domain name, use the **no ip domain-name** *name* global configuration command. To remove a name server address, use the **no ip name-server** *server-address* global configuration command. To disable DNS on the switch, use the **no ip domain-lookup** global configuration command.

Displaying the DNS Configuration

To display the DNS configuration information, use the **show running-config** privileged EXEC command.

Creating a Banner

You can configure a message-of-the-day (MOTD) and a login banner. The MOTD banner displays on all connected terminals at login and is useful for sending messages that affect all network users (such as impending system shutdowns).

The login banner also displays on all connected terminals. It appears after the MOTD banner and before the login prompts.



Note

For complete syntax and usage information for the commands used in this section, see the *Cisco IOS Configuration Fundamentals Command Reference, Release 12.2* from the Cisco.com page under **Documentation > Cisco IOS Software > 12.2 Mainline > Command References**.

These sections contain this configuration information:

- [Default Banner Configuration, page 6-17](#)
- [Configuring a Message-of-the-Day Login Banner, page 6-18](#)
- [Configuring a Login Banner, page 6-19](#)

Default Banner Configuration

The MOTD and login banners are not configured.

Configuring a Message-of-the-Day Login Banner

You can create a single or multiline message banner that appears on the screen when someone logs in to the switch.

Beginning in privileged EXEC mode, follow these steps to configure a MOTD login banner:

	Command	Purpose
Step 1	<code>configure terminal</code>	Enter global configuration mode.
Step 2	<code>banner motd c message c</code>	Specify the message of the day. For <i>c</i> , enter the delimiting character of your choice, for example, a pound sign (#), and press the Return key. The delimiting character signifies the beginning and end of the banner text. Characters after the ending delimiter are discarded. For <i>message</i> , enter a banner message up to 255 characters. You cannot use the delimiting character in the message.
Step 3	<code>end</code>	Return to privileged EXEC mode.
Step 4	<code>show running-config</code>	Verify your entries.
Step 5	<code>copy running-config startup-config</code>	(Optional) Save your entries in the configuration file.

To delete the MOTD banner, use the **no banner motd** global configuration command.

This example shows how to configure a MOTD banner for the switch by using the pound sign (#) symbol as the beginning and ending delimiter:

```
Switch(config)# banner motd #
This is a secure site. Only authorized users are allowed.
For access, contact technical support.
#
Switch(config)#
```

This example shows the banner that appears from the previous configuration:

```
Unix> telnet 172.2.5.4
Trying 172.2.5.4...
Connected to 172.2.5.4.
Escape character is '^]'.

This is a secure site. Only authorized users are allowed.
For access, contact technical support.

User Access Verification

Password:
```

Configuring a Login Banner

You can configure a login banner to be displayed on all connected terminals. This banner appears after the MOTD banner and before the login prompt.

Beginning in privileged EXEC mode, follow these steps to configure a login banner:

	Command	Purpose
Step 1	<code>configure terminal</code>	Enter global configuration mode.
Step 2	<code>banner login c message c</code>	Specify the login message. For <i>c</i> , enter the delimiting character of your choice, for example, a pound sign (#), and press the Return key. The delimiting character signifies the beginning and end of the banner text. Characters after the ending delimiter are discarded. For <i>message</i> , enter a login message up to 255 characters. You cannot use the delimiting character in the message.
Step 3	<code>end</code>	Return to privileged EXEC mode.
Step 4	<code>show running-config</code>	Verify your entries.
Step 5	<code>copy running-config startup-config</code>	(Optional) Save your entries in the configuration file.

To delete the login banner, use the **no banner login** global configuration command.

This example shows how to configure a login banner for the switch by using the dollar sign (\$) symbol as the beginning and ending delimiter:

```
Switch(config)# banner login $
Access for authorized users only. Please enter your username and password.
$
Switch(config)#
```

Managing the MAC Address Table

The MAC address table contains address information that the switch uses to forward traffic between ports. All MAC addresses in the address table are associated with one or more ports. The address table includes these types of addresses:

- Dynamic address: a source MAC address that the switch learns and then ages when it is not in use.
- Static address: a manually entered unicast address that does not age and that is not lost when the switch resets.

The address table lists the destination MAC address, the associated VLAN ID, and port number associated with the address and the type (static or dynamic).



Note

For complete syntax and usage information for the commands used in this section, see the command reference for this release.

These sections contain this configuration information:

- [Building the Address Table, page 6-20](#)
- [MAC Addresses and VLANs, page 6-20](#)
- [Default MAC Address Table Configuration, page 6-21](#)
- [Changing the Address Aging Time, page 6-21](#)
- [Removing Dynamic Address Entries, page 6-22](#)
- [Configuring MAC Address Notification Traps, page 6-22](#)
- [Adding and Removing Static Address Entries, page 6-24](#)
- [Configuring Unicast MAC Address Filtering, page 6-25](#)
- [Displaying Address Table Entries, page 6-26](#)

Building the Address Table

With multiple MAC addresses supported on all ports, you can connect any port on the switch to individual workstations, repeaters, switches, routers, or other network devices. The switch provides dynamic addressing by learning the source address of packets it receives on each port and adding the address and its associated port number to the address table. As stations are added or removed from the network, the switch updates the address table, adding new dynamic addresses and aging out those that are not in use.

The aging interval is globally configured. However, the switch maintains an address table for each VLAN, and STP can accelerate the aging interval on a per-VLAN basis.

The switch sends packets between any combination of ports, based on the destination address of the received packet. Using the MAC address table, the switch forwards the packet only to the port associated with the destination address. If the destination address is on the port that sent the packet, the packet is filtered and not forwarded. The switch always uses the store-and-forward method: complete packets are stored and checked for errors before transmission.

MAC Addresses and VLANs

All addresses are associated with a VLAN. An address can exist in more than one VLAN and have different destinations in each. Unicast addresses, for example, could be forwarded to port 1 in VLAN 1 and ports 9, 10, and 1 in VLAN 5.

Each VLAN maintains its own logical address table. A known address in one VLAN is unknown in another until it is learned or statically associated with a port in the other VLAN.

Default MAC Address Table Configuration

Table 6-3 shows the default MAC address table configuration.

Table 6-3 Default MAC Address Table Configuration

Feature	Default Setting
Aging time	300 seconds
Dynamic addresses	Automatically learned
Static addresses	None configured

Changing the Address Aging Time

Dynamic addresses are source MAC addresses that the switch learns and then ages when they are not in use. You can change the aging time setting for all VLANs or for a specified VLAN.

Setting too short an aging time can cause addresses to be prematurely removed from the table. Then when the switch receives a packet for an unknown destination, it floods the packet to all ports in the same VLAN as the receiving port. This unnecessary flooding can impact performance. Setting too long an aging time can cause the address table to be filled with unused addresses, which prevents new addresses from being learned. Flooding results, which can impact switch performance.

Beginning in privileged EXEC mode, follow these steps to configure the dynamic address table aging time:

	Command	Purpose
Step 1	configure terminal	Enter global configuration mode.
Step 2	mac address-table aging-time [0 10-1000000] [vlan <i>vlan-id</i>]	Set the length of time that a dynamic entry remains in the MAC address table after the entry is used or updated. The range is 10 to 1000000 seconds. The default is 300. You can also enter 0, which disables aging. Static address entries are never aged or removed from the table. For <i>vlan-id</i> , valid IDs are 1 to 4094.
Step 3	end	Return to privileged EXEC mode.
Step 4	show mac address-table aging-time	Verify your entries.
Step 5	copy running-config startup-config	(Optional) Save your entries in the configuration file.

To return to the default value, use the **no mac address-table aging-time** global configuration command.

Removing Dynamic Address Entries

To remove all dynamic entries, use the **clear mac address-table dynamic** command in privileged EXEC mode. You can also remove a specific MAC address (**clear mac address-table dynamic address *mac-address***), remove all addresses on the specified physical port or port channel (**clear mac address-table dynamic interface *interface-id***), or remove all addresses on a specified VLAN (**clear mac address-table dynamic vlan *vlan-id***).

To verify that dynamic entries have been removed, use the **show mac address-table dynamic** privileged EXEC command.

Configuring MAC Address Notification Traps

MAC address notification enables you to track users on a network by storing the MAC address activity on the switch. Whenever the switch learns or removes a MAC address, an SNMP notification can be generated and sent to the NMS. If you have many users coming and going from the network, you can set a trap interval time to bundle the notification traps and reduce network traffic. The MAC notification history table stores the MAC address activity for each hardware port for which the trap is enabled. MAC address notifications are generated for dynamic and secure MAC addresses; events are not generated for self addresses, multicast addresses, or other static addresses.

Beginning in privileged EXEC mode, follow these steps to configure the switch to send MAC address notification traps to an NMS host:

	Command	Purpose
Step 1	configure terminal	Enter global configuration mode.
Step 2	snmp-server host <i>host-addr</i> {traps informs} {version {1 2c 3}} <i>community-string notification-type</i>	Specify the recipient of the trap message. <ul style="list-style-type: none"> For <i>host-addr</i>, specify the name or address of the NMS. Specify traps (the default) to send SNMP traps to the host. Specify informs to send SNMP informs to the host. Specify the SNMP version to support. Version 1, the default, is not available with informs. For <i>community-string</i>, specify the string to send with the notification operation. Though you can set this string by using the snmp-server host command, we recommend that you define this string by using the snmp-server community command before using the snmp-server host command. For <i>notification-type</i>, use the mac-notification keyword.
Step 3	snmp-server enable traps mac-notification	Enable the switch to send MAC address traps to the NMS.
Step 4	mac address-table notification	Enable the MAC address notification feature.

	Command	Purpose
Step 5	mac address-table notification [<i>interval value</i>] [<i>history-size value</i>]	Enter the trap interval time and the history table size. <ul style="list-style-type: none"> (Optional) For interval value, specify the notification trap interval in seconds between each set of traps that are generated to the NMS. The range is 0 to 2147483647 seconds; the default is 1 second. (Optional) For history-size value, specify the maximum number of entries in the MAC notification history table. The range is 0 to 500; the default is 1.
Step 6	interface <i>interface-id</i>	Enter interface configuration mode, and specify the interface on which to enable the SNMP MAC address notification trap.
Step 7	snmp trap mac-notification { added removed }	Enable the MAC address notification trap. <ul style="list-style-type: none"> Enable the MAC notification trap whenever a MAC address is added on this interface. Enable the MAC notification trap whenever a MAC address is removed from this interface.
Step 8	end	Return to privileged EXEC mode.
Step 9	show mac address-table notification interface show running-config	Verify your entries.
Step 10	copy running-config startup-config	(Optional) Save your entries in the configuration file.

To disable the switch from sending MAC address notification traps, use the **no snmp-server enable traps mac-notification** global configuration command. To disable the MAC address notification traps on a specific interface, use the **no snmp trap mac-notification {added | removed}** interface configuration command. To disable the MAC address notification feature, use the **no mac address-table notification** global configuration command.

This example shows how to specify 172.20.10.10 as the NMS, enable the switch to send MAC address notification traps to the NMS, enable the MAC address notification feature, set the interval time to 60 seconds, set the history-size to 100 entries, and enable traps whenever a MAC address is added on the specified port.

```
Switch(config)# snmp-server host 172.20.10.10 traps private
Switch(config)# snmp-server enable traps mac-notification
Switch(config)# mac address-table notification
Switch(config)# mac address-table notification interval 60
Switch(config)# mac address-table notification history-size 100
Switch(config)# interface gigabitethernet0/2
Switch(config-if)# snmp trap mac-notification added
```

You can verify the previous commands by entering the **show mac address-table notification interface** and the **show mac address-table notification** privileged EXEC commands.

Adding and Removing Static Address Entries

A static address has these characteristics:

- It is manually entered in the address table and must be manually removed.
- It can be a unicast or multicast address.
- It does not age and is retained when the switch restarts.

You can add and remove static addresses and define the forwarding behavior for them. The forwarding behavior defines how a port that receives a packet forwards it to another port for transmission. Because all ports are associated with at least one VLAN, the switch acquires the VLAN ID for the address from the ports that you specify. You can specify a different list of destination ports for each source port.

A packet with a static address that arrives on a VLAN where it has not been statically entered is flooded to all ports and not learned.

You add a static address to the address table by specifying the destination MAC unicast address and the VLAN from which it is received. Packets received with this destination address are forwarded to the interface specified with the *interface-id* option.

Beginning in privileged EXEC mode, follow these steps to add a static address:

	Command	Purpose
Step 1	configure terminal	Enter global configuration mode.
Step 2	mac address-table static <i>mac-addr</i> vlan <i>vlan-id</i> interface <i>interface-id</i>	Add a static address to the MAC address table. <ul style="list-style-type: none"> • For <i>mac-addr</i>, specify the destination MAC unicast address to add to the address table. Packets with this destination address received in the specified VLAN are forwarded to the specified interface. • For <i>vlan-id</i>, specify the VLAN for which the packet with the specified MAC address is received. Valid VLAN IDs are 1 to 4094. • For <i>interface-id</i>, specify the interface to which the received packet is forwarded. Valid interfaces include physical ports or port channels. For static multicast addresses, you can enter multiple interface IDs. For static unicast addresses, you can enter only one interface at a time, but you can enter the command multiple times with the same MAC address and VLAN ID.
Step 3	end	Return to privileged EXEC mode.
Step 4	show mac address-table static	Verify your entries.
Step 5	copy running-config startup-config	(Optional) Save your entries in the configuration file.

To remove static entries from the address table, use the **no mac address-table static** *mac-addr* **vlan** *vlan-id* [**interface** *interface-id*] global configuration command.

This example shows how to add the static address c2f3.220a.12f4 to the MAC address table. When a packet is received in VLAN 4 with this MAC address as its destination address, the packet is forwarded to the specified port:

```
Switch(config)# mac address-table static c2f3.220a.12f4 vlan 4 interface
gigabitethernet0/1
```

Configuring Unicast MAC Address Filtering

When unicast MAC address filtering is enabled, the switch drops packets with specific source or destination MAC addresses. This feature is disabled by default and only supports unicast static addresses.

Follow these guidelines when using this feature:

- Multicast MAC addresses, broadcast MAC addresses, and router MAC addresses are not supported. If you specify one of these addresses when entering the **mac address-table static mac-addr vlan vlan-id drop** global configuration command, one of these messages appears:

```
% Only unicast addresses can be configured to be dropped
```

```
% CPU destined address cannot be configured as drop address
```

- Packets that are forwarded to the CPU are also not supported.
- If you add a unicast MAC address as a static address and configure unicast MAC address filtering, the switch either adds the MAC address as a static address or drops packets with that MAC address, depending on which command was entered last. The second command that you entered overrides the first command.

For example, if you enter the **mac address-table static mac-addr vlan vlan-id interface interface-id** global configuration command followed by the **mac address-table static mac-addr vlan vlan-id drop** command, the switch drops packets with the specified MAC address as a source or destination.

If you enter the **mac address-table static mac-addr vlan vlan-id drop** global configuration command followed by the **mac address-table static mac-addr vlan vlan-id interface interface-id** command, the switch adds the MAC address as a static address.

You enable unicast MAC address filtering and configure the switch to drop packets with a specific address by specifying the source or destination unicast MAC address and the VLAN from which it is received.

Beginning in privileged EXEC mode, follow these steps to configure the switch to drop a source or destination unicast static address:

	Command	Purpose
Step 1	configure terminal	Enter global configuration mode.
Step 2	mac address-table static mac-addr vlan vlan-id drop	Enable unicast MAC address filtering and configure the switch to drop a packet with the specified source or destination unicast static address. <ul style="list-style-type: none"> • For <i>mac-addr</i>, specify a source or destination unicast MAC address. Packets with this MAC address are dropped. • For <i>vlan-id</i>, specify the VLAN for which the packet with the specified MAC address is received. Valid VLAN IDs are 1 to 4094.
Step 3	end	Return to privileged EXEC mode.
Step 4	show mac address-table static	Verify your entries.
Step 5	copy running-config startup-config	(Optional) Save your entries in the configuration file.

To disable unicast MAC address filtering, use the **no mac address-table static mac-addr vlan vlan-id** global configuration command.

This example shows how to enable unicast MAC address filtering and to configure the switch to drop packets that have a source or destination address of c2f3.220a.12f4. When a packet is received in VLAN 4 with this MAC address as its source or destination, the packet is dropped:

```
Switch(config)# mac address-table static c2f3.220a.12f4 vlan 4 drop
```

Displaying Address Table Entries

You can display the MAC address table by using one or more of the privileged EXEC commands described in [Table 6-4](#):

Table 6-4 Commands for Displaying the MAC Address Table

Command	Description
show ip igmp snooping groups	Displays the Layer 2 multicast entries for all VLANs or the specified VLAN.
show mac address-table address	Displays MAC address table information for the specified MAC address.
show mac address-table aging-time	Displays the aging time in all VLANs or the specified VLAN.
show mac address-table count	Displays the number of addresses present in all VLANs or the specified VLAN.
show mac address-table dynamic	Displays only dynamic MAC address table entries.
show mac address-table interface	Displays the MAC address table information for the specified interface.
show mac address-table notification	Displays the MAC notification parameters and history table.
show mac address-table static	Displays only static MAC address table entries.
show mac address-table vlan	Displays the MAC address table information for the specified VLAN.

Managing the ARP Table

To communicate with a device (over Ethernet, for example), the software first must learn the 48-bit MAC address or the local data link address of that device. The process of learning the local data link address from an IP address is called *address resolution*.

The Address Resolution Protocol (ARP) associates a host IP address with the corresponding media or MAC addresses and the VLAN ID. Using an IP address, ARP finds the associated MAC address. When a MAC address is found, the IP-MAC address association is stored in an ARP cache for rapid retrieval. Then the IP datagram is encapsulated in a link-layer frame and sent over the network. Encapsulation of IP datagrams and ARP requests and replies on IEEE 802 networks other than Ethernet is specified by the Subnetwork Access Protocol (SNAP). By default, standard Ethernet-style ARP encapsulation (represented by the **arpa** keyword) is enabled on the IP interface.

ARP entries added manually to the table do not age and must be manually removed.



Note

For CLI procedures, see the Cisco IOS Release 12.2 documentation from the Cisco.com page under **Documentation > Cisco IOS Software > 12.2 Mainline**.



CHAPTER 7

Configuring SDM Templates

This chapter describes how to configure the Switch Database Management (SDM) templates on the Catalyst 2960 switch.



Note

For complete syntax and usage information for the commands used in this chapter, see the command reference for this release.

This chapter consists of these sections:

- [Understanding the SDM Templates, page 7-1](#)
- [Configuring the Switch SDM Template, page 7-2](#)
- [.Displaying the SDM Templates, page 7-3](#)

Understanding the SDM Templates

You can use SDM templates to configure system resources in the switch to optimize support for specific features, depending on how the switch is used in the network. You can select a template to provide maximum system usage for some functions or use the default template to balance resources.

To allocate ternary content addressable memory (TCAM) resources for different usages, the switch SDM templates prioritize system resources to optimize support for certain features. You can select SDM templates to optimize these features:

- QoS—The QoS template maximizes system resources for quality of service (QoS) access control entries (ACEs).
- Default—The default template gives balance to all functions.
- Dual—The dual IPv4 and IPv6 Switch Database Management (SDM) template enables a dual stack environment.

[Table 7-1](#) lists the approximate numbers of each resource supported in each template.

Table 7-1 Approximate Number of Feature Resources Allowed by Each Template

Resource	Default	QoS	Dual
Unicast MAC addresses	8 K	8 K	8 K
IPv4 IGMP groups	256	256	256
IPv4 unicast routes	0	0	0

Table 7-1 Approximate Number of Feature Resources Allowed by Each Template (continued)

Resource	Default	QoS	Dual
IPv6 multicast groups	0	0	0
Directly connected IPv6 addresses	0	0	0
Indirect IPv6 unicast routes	0	0	0
IPv4 policy-based routing aces	0	0	0
IPv4 MAC QoS ACEs	128	384	0
IPv4 MAC security ACEs	384	128	256
IPv6 policy-based routing aces	0	0	0
IPv4 MAC QoS ACEs	0	0	0
IPv4 MAC security ACEs	0	0	0

The rows in the tables represent approximate hardware boundaries set when a template is selected. If a section of a hardware resource is full, all processing overflow is sent to the CPU, seriously impacting switch performance.

Configuring the Switch SDM Template

These sections contain this configuration information:

- [Default SDM Template, page 7-2](#)
- [SDM Template Configuration Guidelines, page 7-2](#)
- [Setting the SDM Template, page 7-2](#)

Default SDM Template

The default template is the default.

SDM Template Configuration Guidelines

When you select and configure SDM templates, you must reload the switch for the configuration to take effect.

Setting the SDM Template

Beginning in privileged EXEC mode, follow these steps to use the SDM template to maximize feature usage:

	Command	Purpose
Step 1	<code>configure terminal</code>	Enter global configuration mode.

	Command	Purpose
Step 2	<code>sdm prefer { default dual-ipv4-and-ipv6 default qos }</code>	<p>Specify the SDM template to be used on the switch:</p> <p>The keywords have these meanings:</p> <ul style="list-style-type: none"> • default—Gives balance to all functions. • dual-ipv4-and-ipv6 default—Allows the switch to be used in dual stack environments (supporting both IPv4 and IPv6). • qos—Maximizes system resources for QoS ACEs. <p>Use the no sdm prefer command to set the switch to the default template.</p> <p>The default template balances the use of system resources.</p>
Step 3	<code>end</code>	Return to privileged EXEC mode.
Step 4	<code>reload</code>	Reload the operating system.

After the system reboots, you can use the **show sdm prefer** privileged EXEC command to verify the new template configuration. If you enter the **show sdm prefer** command before you enter the **reload** privileged EXEC command, the **show sdm prefer** command shows the template currently in use and the template that will become active after a reload.

Displaying the SDM Templates

Use the **show sdm prefer** privileged EXEC command with no parameters to display the active template.

Use the **show sdm prefer [default | dual-ipv4-and-ipv6 default | qos]** privileged EXEC command to display the resource numbers supported by the specified template.



CHAPTER 8

Configuring Switch-Based Authentication

This chapter describes how to configure switch-based authentication on the Catalyst 2960 switch. It consists of these sections:

- [Preventing Unauthorized Access to Your Switch, page 8-1](#)
- [Protecting Access to Privileged EXEC Commands, page 8-2](#)
- [Controlling Switch Access with TACACS+, page 8-10](#)
- [Controlling Switch Access with RADIUS, page 8-17](#)
- [Configuring the Switch for Local Authentication and Authorization, page 8-32](#)
- [Configuring the Switch for Secure Shell, page 8-33](#)
- [Configuring the Switch for Secure Socket Layer HTTP, page 8-37](#)
- [Configuring the Switch for Secure Copy Protocol, page 8-43](#)

Preventing Unauthorized Access to Your Switch

You can prevent unauthorized users from reconfiguring your switch and viewing configuration information. Typically, you want network administrators to have access to your switch while you restrict access to users who dial from outside the network through an asynchronous port, connect from outside the network through a serial port, or connect through a terminal or workstation from within the local network.

To prevent unauthorized access into your switch, you should configure one or more of these security features:

- At a minimum, you should configure passwords and privileges at each switch port. These passwords are locally stored on the switch. When users attempt to access the switch through a port or line, they must enter the password specified for the port or line before they can access the switch. For more information, see the [“Protecting Access to Privileged EXEC Commands” section on page 8-2](#).
- For an additional layer of security, you can also configure username and password pairs, which are locally stored on the switch. These pairs are assigned to lines or ports and authenticate each user before that user can access the switch. If you have defined privilege levels, you can also assign a specific privilege level (with associated rights and privileges) to each username and password pair. For more information, see the [“Configuring Username and Password Pairs” section on page 8-6](#).

- If you want to use username and password pairs, but you want to store them centrally on a server instead of locally, you can store them in a database on a security server. Multiple networking devices can then use the same database to obtain user authentication (and, if necessary, authorization) information. For more information, see the [“Controlling Switch Access with TACACS+”](#) section on page 8-10.

Protecting Access to Privileged EXEC Commands

A simple way of providing terminal access control in your network is to use passwords and assign privilege levels. Password protection restricts access to a network or network device. Privilege levels define what commands users can enter after they have logged into a network device.



Note

For complete syntax and usage information for the commands used in this section, see the *Cisco IOS Security Command Reference, Release 12.2* from the Cisco.com page under **Documentation > Cisco IOS Software > 12.2 Mainline > Command References**.

These sections contain this configuration information:

- [Default Password and Privilege Level Configuration, page 8-2](#)
- [Setting or Changing a Static Enable Password, page 8-3](#)
- [Protecting Enable and Enable Secret Passwords with Encryption, page 8-3](#)
- [Disabling Password Recovery, page 8-5](#)
- [Setting a Telnet Password for a Terminal Line, page 8-6](#)
- [Configuring Username and Password Pairs, page 8-6](#)
- [Configuring Multiple Privilege Levels, page 8-7](#)

Default Password and Privilege Level Configuration

[Table 8-1](#) shows the default password and privilege level configuration.

Table 8-1 **Default Password and Privilege Levels**

Feature	Default Setting
Enable password and privilege level	No password is defined. The default is level 15 (privileged EXEC level). The password is not encrypted in the configuration file.
Enable secret password and privilege level	No password is defined. The default is level 15 (privileged EXEC level). The password is encrypted before it is written to the configuration file.
Line password	No password is defined.

Setting or Changing a Static Enable Password

The enable password controls access to the privileged EXEC mode. Beginning in privileged EXEC mode, follow these steps to set or change a static enable password:

	Command	Purpose
Step 1	configure terminal	Enter global configuration mode.
Step 2	enable password <i>password</i>	Define a new password or change an existing password for access to privileged EXEC mode. By default, no password is defined. For <i>password</i> , specify a string from 1 to 25 alphanumeric characters. The string cannot start with a number, is case sensitive, and allows spaces but ignores leading spaces. It can contain the question mark (?) character if you precede the question mark with the key combination Ctrl-v when you create the password; for example, to create the password abc?123, do this: Enter abc . Enter Ctrl-v . Enter ?123 . When the system prompts you to enter the enable password, you need not precede the question mark with the Ctrl-v; you can simply enter abc?123 at the password prompt.
Step 3	end	Return to privileged EXEC mode.
Step 4	show running-config	Verify your entries.
Step 5	copy running-config startup-config	(Optional) Save your entries in the configuration file. The enable password is not encrypted and can be read in the switch configuration file.

To remove the password, use the **no enable password** global configuration command.

This example shows how to change the enable password to *11u2c3k4y5*. The password is not encrypted and provides access to level 15 (traditional privileged EXEC mode access):

```
Switch(config)# enable password 11u2c3k4y5
```

Protecting Enable and Enable Secret Passwords with Encryption

To provide an additional layer of security, particularly for passwords that cross the network or that are stored on a Trivial File Transfer Protocol (TFTP) server, you can use either the **enable password** or **enable secret** global configuration commands. Both commands accomplish the same thing; that is, you can establish an encrypted password that users must enter to access privileged EXEC mode (the default) or any privilege level you specify.

We recommend that you use the **enable secret** command because it uses an improved encryption algorithm.

If you configure the **enable secret** command, it takes precedence over the **enable password** command; the two commands cannot be in effect simultaneously.

Beginning in privileged EXEC mode, follow these steps to configure encryption for enable and enable secret passwords:

	Command	Purpose
Step 1	configure terminal	Enter global configuration mode.
Step 2	enable password [level <i>level</i>] { <i>password</i> <i>encryption-type encrypted-password</i> } or enable secret [level <i>level</i>] { <i>password</i> <i>encryption-type encrypted-password</i> }	Define a new password or change an existing password for access to privileged EXEC mode. or Define a secret password, which is saved using a nonreversible encryption method. <ul style="list-style-type: none"> (Optional) For <i>level</i>, the range is from 0 to 15. Level 1 is normal user EXEC mode privileges. The default level is 15 (privileged EXEC mode privileges). For <i>password</i>, specify a string from 1 to 25 alphanumeric characters. The string cannot start with a number, is case sensitive, and allows spaces but ignores leading spaces. By default, no password is defined. (Optional) For <i>encryption-type</i>, only type 5, a Cisco proprietary encryption algorithm, is available. If you specify an encryption type, you must provide an encrypted password—an encrypted password that you copy from another switch configuration. <p>Note If you specify an encryption type and then enter a clear text password, you can not re-enter privileged EXEC mode. You cannot recover a lost encrypted password by any method.</p>
Step 3	service password-encryption	(Optional) Encrypt the password when the password is defined or when the configuration is written. Encryption prevents the password from being readable in the configuration file.
Step 4	end	Return to privileged EXEC mode.
Step 5	copy running-config startup-config	(Optional) Save your entries in the configuration file.

If both the enable and enable secret passwords are defined, users must enter the enable secret password.

Use the **level** keyword to define a password for a specific privilege level. After you specify the level and set a password, give the password only to users who need to have access at this level. Use the **privilege level** global configuration command to specify commands accessible at various levels. For more information, see the [“Configuring Multiple Privilege Levels” section on page 8-7](#).

If you enable password encryption, it applies to all passwords including username passwords, authentication key passwords, the privileged command password, and console and virtual terminal line passwords.

To remove a password and level, use the **no enable password** [level *level*] or **no enable secret** [level *level*] global configuration command. To disable password encryption, use the **no service password-encryption** global configuration command.

This example shows how to configure the encrypted password `1FaD0$Xyti5Rkls3LoyxzS8` for privilege level 2:

```
Switch(config)# enable secret level 2 5 $1$FaD0$Xyti5Rkls3LoyxzS8
```

Disabling Password Recovery

By default, any end user with physical access to the switch can recover from a lost password by interrupting the boot process while the switch is powering on and then by entering a new password.

The password-recovery disable feature protects access to the switch password by disabling part of this functionality. When this feature is enabled, the end user can interrupt the boot process only by agreeing to set the system back to the default configuration. With password recovery disabled, you can still interrupt the boot process and change the password, but the configuration file (config.text) and the VLAN database file (vlan.dat) are deleted.



Note

If you disable password recovery, we recommend that you keep a backup copy of the configuration file on a secure server in case the end user interrupts the boot process and sets the system back to default values. Do not keep a backup copy of the configuration file on the switch. If the switch is operating in VTP transparent mode, we recommend that you also keep a backup copy of the VLAN database file on a secure server. When the switch is returned to the default system configuration, you can download the saved files to the switch by using the Xmodem protocol. For more information, see the [“Recovering from a Lost or Forgotten Password”](#) section on page 32-3.

Beginning in privileged EXEC mode, follow these steps to disable password recovery:

	Command	Purpose
Step 1	configure terminal	Enter global configuration mode.
Step 2	no service password-recovery	Disable password recovery. This setting is saved in an area of the flash memory that is accessible by the boot loader and the Cisco IOS image, but it is not part of the file system and is not accessible by any user.
Step 3	end	Return to privileged EXEC mode.
Step 4	show version	Verify the configuration by checking the last few lines of the command output.

To re-enable password recovery, use the **service password-recovery** global configuration command.



Note

Disabling password recovery will not work if you have set the switch to boot up manually by using the **boot manual** global configuration command. This command produces the boot loader prompt (*switch:*) after the switch is power cycled.

Setting a Telnet Password for a Terminal Line

When you power-up your switch for the first time, an automatic setup program runs to assign IP information and to create a default configuration for continued use. The setup program also prompts you to configure your switch for Telnet access through a password. If you did not configure this password during the setup program, you can configure it now through the command-line interface (CLI).

Beginning in privileged EXEC mode, follow these steps to configure your switch for Telnet access:

	Command	Purpose
Step 1		Attach a PC or workstation with emulation software to the switch console port. The default data characteristics of the console port are 9600, 8, 1, no parity. You might need to press the Return key several times to see the command-line prompt.
Step 2	<code>enable password <i>password</i></code>	Enter privileged EXEC mode.
Step 3	<code>configure terminal</code>	Enter global configuration mode.
Step 4	<code>line vty 0 15</code>	Configure the number of Telnet sessions (lines), and enter line configuration mode. There are 16 possible sessions on a command-capable switch. The 0 and 15 mean that you are configuring all 16 possible Telnet sessions.
Step 5	<code>password <i>password</i></code>	Enter a Telnet password for the line or lines. For <i>password</i> , specify a string from 1 to 25 alphanumeric characters. The string cannot start with a number, is case sensitive, and allows spaces but ignores leading spaces. By default, no password is defined.
Step 6	<code>end</code>	Return to privileged EXEC mode.
Step 7	<code>show running-config</code>	Verify your entries. The password is listed under the command <code>line vty 0 15</code> .
Step 8	<code>copy running-config startup-config</code>	(Optional) Save your entries in the configuration file.

To remove the password, use the **no password** global configuration command.

This example shows how to set the Telnet password to *let45me67in89*:

```
Switch(config)# line vty 10
Switch(config-line)# password let45me67in89
```

Configuring Username and Password Pairs

You can configure username and password pairs, which are locally stored on the switch. These pairs are assigned to lines or ports and authenticate each user before that user can access the switch. If you have defined privilege levels, you can also assign a specific privilege level (with associated rights and privileges) to each username and password pair.

Beginning in privileged EXEC mode, follow these steps to establish a username-based authentication system that requests a login username and a password:

	Command	Purpose
Step 1	configure terminal	Enter global configuration mode.
Step 2	username <i>name</i> [privilege <i>level</i>] { password <i>encryption-type password</i> }	Enter the username, privilege level, and password for each user. <ul style="list-style-type: none"> For <i>name</i>, specify the user ID as one word. Spaces and quotation marks are not allowed. (Optional) For <i>level</i>, specify the privilege level the user has after gaining access. The range is 0 to 15. Level 15 gives privileged EXEC mode access. Level 1 gives user EXEC mode access. For <i>encryption-type</i>, enter 0 to specify that an unencrypted password will follow. Enter 7 to specify that a hidden password will follow. For <i>password</i>, specify the password the user must enter to gain access to the switch. The password must be from 1 to 25 characters, can contain embedded spaces, and must be the last option specified in the username command.
Step 3	line console 0 or line vty 0 15	Enter line configuration mode, and configure the console port (line 0) or the VTY lines (line 0 to 15).
Step 4	login local	Enable local password checking at login time. Authentication is based on the username specified in Step 2.
Step 5	end	Return to privileged EXEC mode.
Step 6	show running-config	Verify your entries.
Step 7	copy running-config startup-config	(Optional) Save your entries in the configuration file.

To disable username authentication for a specific user, use the **no username** *name* global configuration command. To disable password checking and allow connections without a password, use the **no login** line configuration command.

Configuring Multiple Privilege Levels

By default, the Cisco IOS software has two modes of password security: user EXEC and privileged EXEC. You can configure up to 16 hierarchical levels of commands for each mode. By configuring multiple passwords, you can allow different sets of users to have access to specified commands.

For example, if you want many users to have access to the **clear line** command, you can assign it level 2 security and distribute the level 2 password fairly widely. But if you want more restricted access to the **configure** command, you can assign it level 3 security and distribute that password to a more restricted group of users.

These sections contain this configuration information:

- [Setting the Privilege Level for a Command, page 8-8](#)
- [Changing the Default Privilege Level for Lines, page 8-9](#)
- [Logging into and Exiting a Privilege Level, page 8-9](#)

Setting the Privilege Level for a Command

Beginning in privileged EXEC mode, follow these steps to set the privilege level for a command mode:

	Command	Purpose
Step 1	configure terminal	Enter global configuration mode.
Step 2	privilege mode level level command	Set the privilege level for a command. <ul style="list-style-type: none"> For <i>mode</i>, enter configure for global configuration mode, exec for EXEC mode, interface for interface configuration mode, or line for line configuration mode. For <i>level</i>, the range is from 0 to 15. Level 1 is for normal user EXEC mode privileges. Level 15 is the level of access permitted by the enable password. For <i>command</i>, specify the command to which you want to restrict access.
Step 3	enable password level level password	Specify the enable password for the privilege level. <ul style="list-style-type: none"> For <i>level</i>, the range is from 0 to 15. Level 1 is for normal user EXEC mode privileges. For <i>password</i>, specify a string from 1 to 25 alphanumeric characters. The string cannot start with a number, is case sensitive, and allows spaces but ignores leading spaces. By default, no password is defined.
Step 4	end	Return to privileged EXEC mode.
Step 5	show running-config or show privilege	Verify your entries. The first command shows the password and access level configuration. The second command shows the privilege level configuration.
Step 6	copy running-config startup-config	(Optional) Save your entries in the configuration file.

When you set a command to a privilege level, all commands whose syntax is a subset of that command are also set to that level. For example, if you set the **show ip traffic** command to level 15, the **show** commands and **show ip** commands are automatically set to privilege level 15 unless you set them individually to different levels.

To return to the default privilege for a given command, use the **no privilege mode level level command** global configuration command.

This example shows how to set the **configure** command to privilege level 14 and define *SecretPswd14* as the password users must enter to use level 14 commands:

```
Switch(config)# privilege exec level 14 configure
Switch(config)# enable password level 14 SecretPswd14
```

Changing the Default Privilege Level for Lines

Beginning in privileged EXEC mode, follow these steps to change the default privilege level for a line:

	Command	Purpose
Step 1	configure terminal	Enter global configuration mode.
Step 2	line vty line	Select the virtual terminal line on which to restrict access.
Step 3	privilege level level	Change the default privilege level for the line. For <i>level</i> , the range is from 0 to 15. Level 1 is for normal user EXEC mode privileges. Level 15 is the level of access permitted by the enable password.
Step 4	end	Return to privileged EXEC mode.
Step 5	show running-config or show privilege	Verify your entries. The first command shows the password and access level configuration. The second command shows the privilege level configuration.
Step 6	copy running-config startup-config	(Optional) Save your entries in the configuration file.

Users can override the privilege level you set using the **privilege level** line configuration command by logging in to the line and enabling a different privilege level. They can lower the privilege level by using the **disable** command. If users know the password to a higher privilege level, they can use that password to enable the higher privilege level. You might specify a high level or privilege level for your console line to restrict line usage.

To return to the default line privilege level, use the **no privilege level** line configuration command.

Logging into and Exiting a Privilege Level

Beginning in privileged EXEC mode, follow these steps to log in to a specified privilege level and to exit to a specified privilege level:

	Command	Purpose
Step 1	enable level	Log in to a specified privilege level. For <i>level</i> , the range is 0 to 15.
Step 2	disable level	Exit to a specified privilege level. For <i>level</i> , the range is 0 to 15.

Controlling Switch Access with TACACS+

This section describes how to enable and configure Terminal Access Controller Access Control System Plus (TACACS+), which provides detailed accounting information and flexible administrative control over authentication and authorization processes. TACACS+ is facilitated through authentication, authorization, accounting (AAA) and can be enabled only through AAA commands.

**Note**

For complete syntax and usage information for the commands used in this section, see the *Cisco IOS Security Command Reference, Release 12.2*.

These sections contain this configuration information:

- [Understanding TACACS+, page 8-10](#)
- [TACACS+ Operation, page 8-12](#)
- [Configuring TACACS+, page 8-12](#)
- [Displaying the TACACS+ Configuration, page 8-17](#)

Understanding TACACS+

TACACS+ is a security application that provides centralized validation of users attempting to gain access to your switch. TACACS+ services are maintained in a database on a TACACS+ daemon typically running on a UNIX or Windows NT workstation. You should have access to and should configure a TACACS+ server before the configuring TACACS+ features on your switch.

TACACS+ provides for separate and modular authentication, authorization, and accounting facilities. TACACS+ allows for a single access control server (the TACACS+ daemon) to provide each service—authentication, authorization, and accounting—independently. Each service can be tied into its own database to take advantage of other services available on that server or on the network, depending on the capabilities of the daemon.

The goal of TACACS+ is to provide a method for managing multiple network access points from a single management service. Your switch can be a network access server along with other Cisco routers and access servers. A network access server provides connections to a single user, to a network or subnetwork, and to interconnected networks as shown in [Figure 8-1](#).

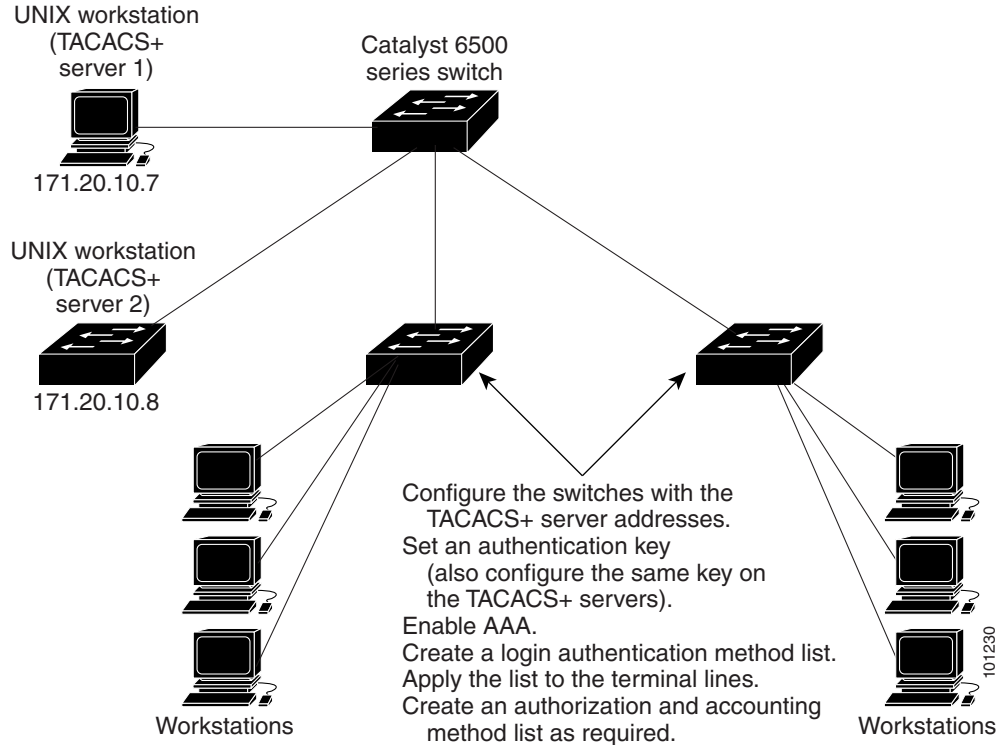
Figure 8-1 Typical TACACS+ Network Configuration

TACACS+, administered through the AAA security services, can provide these services:

- **Authentication**—Provides complete control of authentication through login and password dialog, challenge and response, and messaging support.
The authentication facility can conduct a dialog with the user (for example, after a username and password are provided, to challenge a user with several questions, such as home address, mother's maiden name, service type, and social security number). The TACACS+ authentication service can also send messages to user screens. For example, a message could notify users that their passwords must be changed because of the company's password aging policy.
- **Authorization**—Provides fine-grained control over user capabilities for the duration of the user's session, including but not limited to setting autocommands, access control, session duration, or protocol support. You can also enforce restrictions on what commands a user can execute with the TACACS+ authorization feature.
- **Accounting**—Collects and sends information used for billing, auditing, and reporting to the TACACS+ daemon. Network managers can use the accounting facility to track user activity for a security audit or to provide information for user billing. Accounting records include user identities, start and stop times, executed commands (such as PPP), number of packets, and number of bytes.

The TACACS+ protocol provides authentication between the switch and the TACACS+ daemon, and it ensures confidentiality because all protocol exchanges between the switch and the TACACS+ daemon are encrypted.

You need a system running the TACACS+ daemon software to use TACACS+ on your switch.

TACACS+ Operation

When a user attempts a simple ASCII login by authenticating to a switch using TACACS+, this process occurs:

1. When the connection is established, the switch contacts the TACACS+ daemon to obtain a username prompt to show to the user. The user enters a username, and the switch then contacts the TACACS+ daemon to obtain a password prompt. The switch displays the password prompt to the user, the user enters a password, and the password is then sent to the TACACS+ daemon.

TACACS+ allows a dialog between the daemon and the user until the daemon receives enough information to authenticate the user. The daemon prompts for a username and password combination, but can include other items, such as the user's mother's maiden name.

2. The switch eventually receives one of these responses from the TACACS+ daemon:
 - **ACCEPT**—The user is authenticated and service can begin. If the switch is configured to require authorization, authorization begins at this time.
 - **REJECT**—The user is not authenticated. The user can be denied access or is prompted to retry the login sequence, depending on the TACACS+ daemon.
 - **ERROR**—An error occurred at some time during authentication with the daemon or in the network connection between the daemon and the switch. If an **ERROR** response is received, the switch typically tries to use an alternative method for authenticating the user.
 - **CONTINUE**—The user is prompted for additional authentication information.

After authentication, the user undergoes an additional authorization phase if authorization has been enabled on the switch. Users must first successfully complete TACACS+ authentication before proceeding to TACACS+ authorization.

3. If TACACS+ authorization is required, the TACACS+ daemon is again contacted, and it returns an **ACCEPT** or **REJECT** authorization response. If an **ACCEPT** response is returned, the response contains data in the form of attributes that direct the **EXEC** or **NETWORK** session for that user and the services that the user can access:
 - Telnet, Secure Shell (SSH), rlogin, or privileged **EXEC** services
 - Connection parameters, including the host or client IP address, access list, and user timeouts

Configuring TACACS+

This section describes how to configure your switch to support TACACS+. At a minimum, you must identify the host or hosts maintaining the TACACS+ daemon and define the method lists for TACACS+ authentication. You can optionally define method lists for TACACS+ authorization and accounting. A method list defines the sequence and methods to be used to authenticate, to authorize, or to keep accounts on a user. You can use method lists to designate one or more security protocols to be used, thus ensuring a backup system if the initial method fails. The software uses the first method listed to authenticate, to

authorize, or to keep accounts on users; if that method does not respond, the software selects the next method in the list. This process continues until there is successful communication with a listed method or the method list is exhausted.

These sections contain this configuration information:

- [Default TACACS+ Configuration, page 8-13](#)
- [Identifying the TACACS+ Server Host and Setting the Authentication Key, page 8-13](#)
- [Configuring TACACS+ Login Authentication, page 8-14](#)
- [Configuring TACACS+ Authorization for Privileged EXEC Access and Network Services, page 8-16](#)
- [Starting TACACS+ Accounting, page 8-17](#)

Default TACACS+ Configuration

TACACS+ and AAA are disabled by default.

To prevent a lapse in security, you cannot configure TACACS+ through a network management application. When enabled, TACACS+ can authenticate users accessing the switch through the CLI.



Note

Although TACACS+ configuration is performed through the CLI, the TACACS+ server authenticates HTTP connections that have been configured with a privilege level of 15.

Identifying the TACACS+ Server Host and Setting the Authentication Key

You can configure the switch to use a single server or AAA server groups to group existing server hosts for authentication. You can group servers to select a subset of the configured server hosts and use them for a particular service. The server group is used with a global server-host list and contains the list of IP addresses of the selected server hosts.

Beginning in privileged EXEC mode, follow these steps to identify the IP host or host maintaining TACACS+ server and optionally set the encryption key:

	Command	Purpose
Step 1	configure terminal	Enter global configuration mode.
Step 2	tacacs-server host <i>hostname</i> [port <i>integer</i>] [timeout <i>integer</i>] [key <i>string</i>]	<p>Identify the IP host or hosts maintaining a TACACS+ server. Enter this command multiple times to create a list of preferred hosts. The software searches for hosts in the order in which you specify them.</p> <ul style="list-style-type: none"> • For <i>hostname</i>, specify the name or IP address of the host. • (Optional) For port <i>integer</i>, specify a server port number. The default is port 49. The range is 1 to 65535. • (Optional) For timeout <i>integer</i>, specify a time in seconds the switch waits for a response from the daemon before it times out and declares an error. The default is 5 seconds. The range is 1 to 1000 seconds. • (Optional) For key <i>string</i>, specify the encryption key for encrypting and decrypting all traffic between the switch and the TACACS+ daemon. You must configure the same key on the TACACS+ daemon for encryption to be successful.

	Command	Purpose
Step 3	aaa new-model	Enable AAA.
Step 4	aaa group server tacacs+ <i>group-name</i>	(Optional) Define the AAA server-group with a group name. This command puts the switch in a server group subconfiguration mode.
Step 5	server <i>ip-address</i>	(Optional) Associate a particular TACACS+ server with the defined server group. Repeat this step for each TACACS+ server in the AAA server group. Each server in the group must be previously defined in Step 2.
Step 6	end	Return to privileged EXEC mode.
Step 7	show tacacs	Verify your entries.
Step 8	copy running-config startup-config	(Optional) Save your entries in the configuration file.

To remove the specified TACACS+ server name or address, use the **no tacacs-server host *hostname*** global configuration command. To remove a server group from the configuration list, use the **no aaa group server tacacs+ *group-name*** global configuration command. To remove the IP address of a TACACS+ server, use the **no server *ip-address*** server group subconfiguration command.

Configuring TACACS+ Login Authentication

To configure AAA authentication, you define a named list of authentication methods and then apply that list to various ports. The method list defines the types of authentication to be performed and the sequence in which they are performed; it must be applied to a specific port before any of the defined authentication methods are performed. The only exception is the default method list (which, by coincidence, is named *default*). The default method list is automatically applied to all ports except those that have a named method list explicitly defined. A defined method list overrides the default method list.

A method list describes the sequence and authentication methods to be queried to authenticate a user. You can designate one or more security protocols to be used for authentication, thus ensuring a backup system for authentication in case the initial method fails. The software uses the first method listed to authenticate users; if that method fails to respond, the software selects the next authentication method in the method list. This process continues until there is successful communication with a listed authentication method or until all defined methods are exhausted. If authentication fails at any point in this cycle—meaning that the security server or local username database responds by denying the user access—the authentication process stops, and no other authentication methods are attempted.

Beginning in privileged EXEC mode, follow these steps to configure login authentication:

	Command	Purpose
Step 1	configure terminal	Enter global configuration mode.
Step 2	aaa new-model	Enable AAA.

	Command	Purpose
Step 3	aaa authentication login { default <i>list-name</i> } <i>method1</i> [<i>method2...</i>]	<p>Create a login authentication method list.</p> <ul style="list-style-type: none"> To create a default list that is used when a named list is <i>not</i> specified in the login authentication command, use the default keyword followed by the methods that are to be used in default situations. The default method list is automatically applied to all ports. For <i>list-name</i>, specify a character string to name the list you are creating. For <i>method1...</i>, specify the actual method the authentication algorithm tries. The additional methods of authentication are used only if the previous method returns an error, not if it fails. <p>Select one of these methods:</p> <ul style="list-style-type: none"> enable—Use the enable password for authentication. Before you can use this authentication method, you must define an enable password by using the enable password global configuration command. group tacacs+—Uses TACACS+ authentication. Before you can use this authentication method, you must configure the TACACS+ server. For more information, see the “Identifying the TACACS+ Server Host and Setting the Authentication Key” section on page 8-13. line—Use the line password for authentication. Before you can use this authentication method, you must define a line password. Use the password password line configuration command. local—Use the local username database for authentication. You must enter username information in the database. Use the username password global configuration command. local-case—Use a case-sensitive local username database for authentication. You must enter username information in the database by using the username name password global configuration command. none—Do not use any authentication for login.
Step 4	line [console tty vty] <i>line-number</i> [<i>ending-line-number</i>]	Enter line configuration mode, and configure the lines to which you want to apply the authentication list.
Step 5	login authentication { default <i>list-name</i> }	<p>Apply the authentication list to a line or set of lines.</p> <ul style="list-style-type: none"> If you specify default, use the default list created with the aaa authentication login command. For <i>list-name</i>, specify the list created with the aaa authentication login command.
Step 6	end	Return to privileged EXEC mode.
Step 7	show running-config	Verify your entries.
Step 8	copy running-config startup-config	(Optional) Save your entries in the configuration file.

To disable AAA, use the **no aaa new-model** global configuration command. To disable AAA authentication, use the **no aaa authentication login** { **default** | *list-name* } *method1* [*method2...*] global configuration command. To either disable TACACS+ authentication for logins or to return to the default value, use the **no login authentication** { **default** | *list-name* } line configuration command.

**Note**

To secure the switch for HTTP access by using AAA methods, you must configure the switch with the **ip http authentication aaa** global configuration command. Configuring AAA authentication does not secure the switch for HTTP access by using AAA methods.

For more information about the **ip http authentication** command, see the *Cisco IOS Security Command Reference, Release 12.2* from the Cisco.com page under **Documentation > Cisco IOS Software > 12.2 Mainline > Command References**.

Configuring TACACS+ Authorization for Privileged EXEC Access and Network Services

AAA authorization limits the services available to a user. When AAA authorization is enabled, the switch uses information retrieved from the user's profile, which is located either in the local user database or on the security server, to configure the user's session. The user is granted access to a requested service only if the information in the user profile allows it.

You can use the **aaa authorization** global configuration command with the **tacacs+** keyword to set parameters that restrict a user's network access to privileged EXEC mode.

The **aaa authorization exec tacacs+ local** command sets these authorization parameters:

- Use TACACS+ for privileged EXEC access authorization if authentication was performed by using TACACS+.
- Use the local database if authentication was not performed by using TACACS+.

**Note**

Authorization is bypassed for authenticated users who log in through the CLI even if authorization has been configured.

Beginning in privileged EXEC mode, follow these steps to specify TACACS+ authorization for privileged EXEC access and network services:

	Command	Purpose
Step 1	configure terminal	Enter global configuration mode.
Step 2	aaa authorization network tacacs+	Configure the switch for user TACACS+ authorization for all network-related service requests.
Step 3	aaa authorization exec tacacs+	Configure the switch for user TACACS+ authorization if the user has privileged EXEC access. The exec keyword might return user profile information (such as autocommand information).
Step 4	end	Return to privileged EXEC mode.
Step 5	show running-config	Verify your entries.
Step 6	copy running-config startup-config	(Optional) Save your entries in the configuration file.

To disable authorization, use the **no aaa authorization {network | exec} method1** global configuration command.

Starting TACACS+ Accounting

The AAA accounting feature tracks the services that users are accessing and the amount of network resources that they are consuming. When AAA accounting is enabled, the switch reports user activity to the TACACS+ security server in the form of accounting records. Each accounting record contains accounting attribute-value (AV) pairs and is stored on the security server. This data can then be analyzed for network management, client billing, or auditing.

Beginning in privileged EXEC mode, follow these steps to enable TACACS+ accounting for each Cisco IOS privilege level and for network services:

	Command	Purpose
Step 1	configure terminal	Enter global configuration mode.
Step 2	aaa accounting network start-stop tacacs+	Enable TACACS+ accounting for all network-related service requests.
Step 3	aaa accounting exec start-stop tacacs+	Enable TACACS+ accounting to send a start-record accounting notice at the beginning of a privileged EXEC process and a stop-record at the end.
Step 4	end	Return to privileged EXEC mode.
Step 5	show running-config	Verify your entries.
Step 6	copy running-config startup-config	(Optional) Save your entries in the configuration file.

To disable accounting, use the **no aaa accounting {network | exec} {start-stop} method1...** global configuration command.

Displaying the TACACS+ Configuration

To display TACACS+ server statistics, use the **show tacacs** privileged EXEC command.

Controlling Switch Access with RADIUS

This section describes how to enable and configure the RADIUS, which provides detailed accounting information and flexible administrative control over authentication and authorization processes. RADIUS is facilitated through AAA and can be enabled only through AAA commands.



Note

For complete syntax and usage information for the commands used in this section, see the *Cisco IOS Security Command Reference, Release 12.2* from the Cisco.com page under **Documentation > Cisco IOS Software > 12.2 Mainline > Command References**.

These sections contain this configuration information:

- [Understanding RADIUS, page 8-18](#)
- [RADIUS Operation, page 8-19](#)
- [Configuring RADIUS, page 8-19](#)
- [Displaying the RADIUS Configuration, page 8-31](#)

Understanding RADIUS

RADIUS is a distributed client/server system that secures networks against unauthorized access. RADIUS clients run on supported Cisco routers and switches. Clients send authentication requests to a central RADIUS server, which contains all user authentication and network service access information. The RADIUS host is normally a multiuser system running RADIUS server software from Cisco (Cisco Secure Access Control Server Version 3.0), Livingston, Merit, Microsoft, or another software provider. For more information, see the RADIUS server documentation.

Use RADIUS in these network environments that require access security:

- Networks with multiple-vendor access servers, each supporting RADIUS. For example, access servers from several vendors use a single RADIUS server-based security database. In an IP-based network with multiple vendors' access servers, dial-in users are authenticated through a RADIUS server that has been customized to work with the Kerberos security system.
- Turnkey network security environments in which applications support the RADIUS protocol, such as in an access environment that uses a *smart card* access control system. In one case, RADIUS has been used with Enigma's security cards to validate users and to grant access to network resources.
- Networks already using RADIUS. You can add a Cisco switch containing a RADIUS client to the network. This might be the first step when you make a transition to a TACACS+ server. See [Figure 8-2 on page 8-19](#).
- Network in which the user must only access a single service. Using RADIUS, you can control user access to a single host, to a single utility such as Telnet, or to the network through a protocol such as IEEE 802.1x. For more information about this protocol, see [Chapter 9, "Configuring IEEE 802.1x Port-Based Authentication."](#)
- Networks that require resource accounting. You can use RADIUS accounting independently of RADIUS authentication or authorization. The RADIUS accounting functions allow data to be sent at the start and end of services, showing the amount of resources (such as time, packets, bytes, and so forth) used during the session. An Internet service provider might use a freeware-based version of RADIUS access control and accounting software to meet special security and billing needs.

RADIUS is not suitable in these network security situations:

- Multiprotocol access environments. RADIUS does not support AppleTalk Remote Access (ARA), NetBIOS Frame Control Protocol (NBFCP), NetWare Asynchronous Services Interface (NASI), or X.25 PAD connections.
- Switch-to-switch or router-to-router situations. RADIUS does not provide two-way authentication. RADIUS can be used to authenticate from one device to a non-Cisco device if the non-Cisco device requires authentication.
- Networks using a variety of services. RADIUS generally binds a user to one service model.

Figure 8-2 *Transitioning from RADIUS to TACACS+ Services*

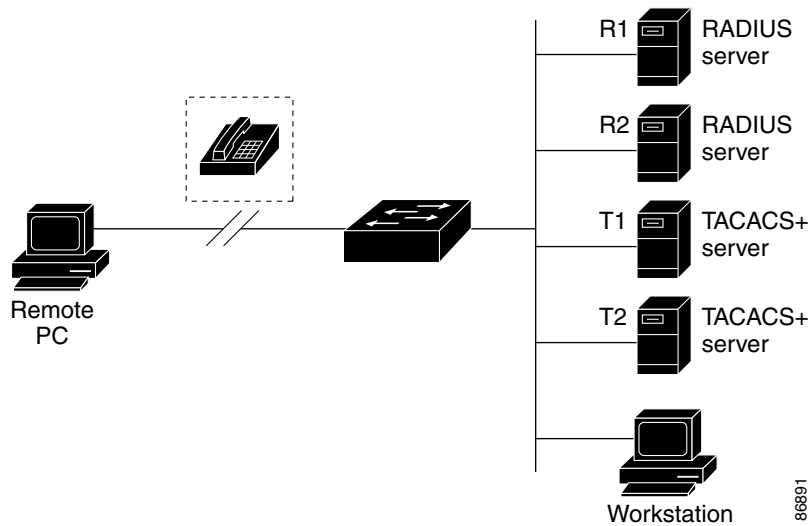

RADIUS Operation

When a user attempts to log in and authenticate to a switch that is access controlled by a RADIUS server, these events occur:

1. The user is prompted to enter a username and password.
2. The username and encrypted password are sent over the network to the RADIUS server.
3. The user receives one of these responses from the RADIUS server:
 - a. ACCEPT—The user is authenticated.
 - b. REJECT—The user is either not authenticated and is prompted to re-enter the username and password, or access is denied.
 - c. CHALLENGE—A challenge requires additional data from the user.
 - d. CHALLENGE PASSWORD—A response requests the user to select a new password.

The ACCEPT or REJECT response is bundled with additional data that is used for privileged EXEC or network authorization. Users must first successfully complete RADIUS authentication before proceeding to RADIUS authorization, if it is enabled. The additional data included with the ACCEPT or REJECT packets includes these items:

- Telnet, SSH, rlogin, or privileged EXEC services
- Connection parameters, including the host or client IP address, access list, and user timeouts

Configuring RADIUS

This section describes how to configure your switch to support RADIUS. At a minimum, you must identify the host or hosts that run the RADIUS server software and define the method lists for RADIUS authentication. You can optionally define method lists for RADIUS authorization and accounting.

A method list defines the sequence and methods to be used to authenticate, to authorize, or to keep accounts on a user. You can use method lists to designate one or more security protocols to be used (such as TACACS+ or local username lookup), thus ensuring a backup system if the initial method fails. The

software uses the first method listed to authenticate, to authorize, or to keep accounts on users; if that method does not respond, the software selects the next method in the list. This process continues until there is successful communication with a listed method or the method list is exhausted.

You should have access to and should configure a RADIUS server before configuring RADIUS features on your switch.

These sections contain this configuration information:

- [Default RADIUS Configuration, page 8-20](#)
- [Identifying the RADIUS Server Host, page 8-20](#) (required)
- [Configuring RADIUS Login Authentication, page 8-23](#) (required)
- [Defining AAA Server Groups, page 8-25](#) (optional)
- [Configuring RADIUS Authorization for User Privileged Access and Network Services, page 8-27](#) (optional)
- [Starting RADIUS Accounting, page 8-28](#) (optional)
- [Configuring Settings for All RADIUS Servers, page 8-29](#) (optional)
- [Configuring the Switch to Use Vendor-Specific RADIUS Attributes, page 8-29](#) (optional)
- [Configuring the Switch for Vendor-Proprietary RADIUS Server Communication, page 8-31](#) (optional)

Default RADIUS Configuration

RADIUS and AAA are disabled by default.

To prevent a lapse in security, you cannot configure RADIUS through a network management application. When enabled, RADIUS can authenticate users accessing the switch through the CLI.

Identifying the RADIUS Server Host

Switch-to-RADIUS-server communication involves several components:

- Hostname or IP address
- Authentication destination port
- Accounting destination port
- Key string
- Timeout period
- Retransmission value

You identify RADIUS security servers by their hostname or IP address, hostname and specific UDP port numbers, or their IP address and specific UDP port numbers. The combination of the IP address and the UDP port number creates a unique identifier, allowing different ports to be individually defined as RADIUS hosts providing a specific AAA service. This unique identifier enables RADIUS requests to be sent to multiple UDP ports on a server at the same IP address.

If two different host entries on the same RADIUS server are configured for the same service—for example, accounting—the second host entry configured acts as a fail-over backup to the first one. Using this example, if the first host entry fails to provide accounting services, the `%RADIUS-4-RADIUS_DEAD` message appears, and then the switch tries the second host entry configured on the same device for accounting services. (The RADIUS host entries are tried in the order that they are configured.)

A RADIUS server and the switch use a shared secret text string to encrypt passwords and exchange responses. To configure RADIUS to use the AAA security commands, you must specify the host running the RADIUS server daemon and a secret text (key) string that it shares with the switch.

The timeout, retransmission, and encryption key values can be configured globally for all RADIUS servers, on a per-server basis, or in some combination of global and per-server settings. To apply these settings globally to all RADIUS servers communicating with the switch, use the three unique global configuration commands: **radius-server timeout**, **radius-server retransmit**, and **radius-server key**. To apply these values on a specific RADIUS server, use the **radius-server host** global configuration command.

**Note**

If you configure both global and per-server functions (timeout, retransmission, and key commands) on the switch, the per-server timer, retransmission, and key value commands override global timer, retransmission, and key value commands. For information on configuring these settings on all RADIUS servers, see the [“Configuring Settings for All RADIUS Servers” section on page 8-29](#).

You can configure the switch to use AAA server groups to group existing server hosts for authentication. For more information, see the [“Defining AAA Server Groups” section on page 8-25](#).

Beginning in privileged EXEC mode, follow these steps to configure per-server RADIUS server communication. This procedure is required.

	Command	Purpose
Step 1	configure terminal	Enter global configuration mode.
Step 2	radius-server host { <i>hostname</i> <i>ip-address</i> } [auth-port <i>port-number</i>] [acct-port <i>port-number</i>] [timeout <i>seconds</i>] [retransmit <i>retries</i>] [key <i>string</i>]	<p>Specify the IP address or hostname of the remote RADIUS server host.</p> <ul style="list-style-type: none"> (Optional) For auth-port <i>port-number</i>, specify the UDP destination port for authentication requests. (Optional) For acct-port <i>port-number</i>, specify the UDP destination port for accounting requests. (Optional) For timeout <i>seconds</i>, specify the time interval that the switch waits for the RADIUS server to reply before resending. The range is 1 to 1000. This setting overrides the radius-server timeout global configuration command setting. If no timeout is set with the radius-server host command, the setting of the radius-server timeout command is used. (Optional) For retransmit <i>retries</i>, specify the number of times a RADIUS request is resent to a server if that server is not responding or responding slowly. The range is 1 to 1000. If no retransmit value is set with the radius-server host command, the setting of the radius-server retransmit global configuration command is used. (Optional) For key <i>string</i>, specify the authentication and encryption key used between the switch and the RADIUS daemon running on the RADIUS server. <p>Note The key is a text string that must match the encryption key used on the RADIUS server. Always configure the key as the last item in the radius-server host command. Leading spaces are ignored, but spaces within and at the end of the key are used. If you use spaces in your key, do not enclose the key in quotation marks unless the quotation marks are part of the key.</p> <p>To configure the switch to recognize more than one host entry associated with a single IP address, enter this command as many times as necessary, making sure that each UDP port number is different. The switch software searches for hosts in the order in which you specify them. Set the timeout, retransmit, and encryption key values to use with the specific RADIUS host.</p>
Step 3	end	Return to privileged EXEC mode.
Step 4	show running-config	Verify your entries.
Step 5	copy running-config startup-config	(Optional) Save your entries in the configuration file.

To remove the specified RADIUS server, use the **no radius-server host** *hostname* | *ip-address* global configuration command.

This example shows how to configure one RADIUS server to be used for authentication and another to be used for accounting:

```
Switch(config)# radius-server host 172.29.36.49 auth-port 1612 key rad1
Switch(config)# radius-server host 172.20.36.50 acct-port 1618 key rad2
```

This example shows how to configure *host1* as the RADIUS server and to use the default ports for both authentication and accounting:

```
Switch(config)# radius-server host host1
```



Note

You also need to configure some settings on the RADIUS server. These settings include the IP address of the switch and the key string to be shared by both the server and the switch. For more information, see the RADIUS server documentation.

Configuring RADIUS Login Authentication

To configure AAA authentication, you define a named list of authentication methods and then apply that list to various ports. The method list defines the types of authentication to be performed and the sequence in which they are performed; it must be applied to a specific port before any of the defined authentication methods are performed. The only exception is the default method list (which, by coincidence, is named *default*). The default method list is automatically applied to all ports except those that have a named method list explicitly defined.

A method list describes the sequence and authentication methods to be queried to authenticate a user. You can designate one or more security protocols to be used for authentication, thus ensuring a backup system for authentication in case the initial method fails. The software uses the first method listed to authenticate users; if that method fails to respond, the software selects the next authentication method in the method list. This process continues until there is successful communication with a listed authentication method or until all defined methods are exhausted. If authentication fails at any point in this cycle—meaning that the security server or local username database responds by denying the user access—the authentication process stops, and no other authentication methods are attempted.

Beginning in privileged EXEC mode, follow these steps to configure login authentication. This procedure is required.

	Command	Purpose
Step 1	<code>configure terminal</code>	Enter global configuration mode.
Step 2	<code>aaa new-model</code>	Enable AAA.

	Command	Purpose
Step 3	aaa authentication login { default <i>list-name</i> } <i>method1</i> [<i>method2</i> ...]	<p>Create a login authentication method list.</p> <ul style="list-style-type: none"> To create a default list that is used when a named list is <i>not</i> specified in the login authentication command, use the default keyword followed by the methods that are to be used in default situations. The default method list is automatically applied to all ports. For <i>list-name</i>, specify a character string to name the list you are creating. For <i>method1</i>..., specify the actual method the authentication algorithm tries. The additional methods of authentication are used only if the previous method returns an error, not if it fails. <p>Select one of these methods:</p> <ul style="list-style-type: none"> enable—Use the enable password for authentication. Before you can use this authentication method, you must define an enable password by using the enable password global configuration command. group radius—Use RADIUS authentication. Before you can use this authentication method, you must configure the RADIUS server. For more information, see the “Identifying the RADIUS Server Host” section on page 8-20. line—Use the line password for authentication. Before you can use this authentication method, you must define a line password. Use the password password line configuration command. local—Use the local username database for authentication. You must enter username information in the database. Use the username name password global configuration command. local-case—Use a case-sensitive local username database for authentication. You must enter username information in the database by using the username password global configuration command. none—Do not use any authentication for login.
Step 4	line [console tty vty] <i>line-number</i> [<i>ending-line-number</i>]	Enter line configuration mode, and configure the lines to which you want to apply the authentication list.
Step 5	login authentication { default <i>list-name</i> }	<p>Apply the authentication list to a line or set of lines.</p> <ul style="list-style-type: none"> If you specify default, use the default list created with the aaa authentication login command. For <i>list-name</i>, specify the list created with the aaa authentication login command.
Step 6	end	Return to privileged EXEC mode.
Step 7	show running-config	Verify your entries.
Step 8	copy running-config startup-config	(Optional) Save your entries in the configuration file.

To disable AAA, use the **no aaa new-model** global configuration command. To disable AAA authentication, use the **no aaa authentication login {default | list-name} method1 [method2...]** global configuration command. To either disable RADIUS authentication for logins or to return to the default value, use the **no login authentication {default | list-name}** line configuration command.

**Note**

To secure the switch for HTTP access by using AAA methods, you must configure the switch with the **ip http authentication aaa** global configuration command. Configuring AAA authentication does not secure the switch for HTTP access by using AAA methods.

For more information about the **ip http authentication** command, see the *Cisco IOS Security Command Reference, Release 12.2* from the Cisco.com page under **Documentation > Cisco IOS Software > 12.2 Mainline > Command References**.

Defining AAA Server Groups

You can configure the switch to use AAA server groups to group existing server hosts for authentication. You select a subset of the configured server hosts and use them for a particular service. The server group is used with a global server-host list, which lists the IP addresses of the selected server hosts.

Server groups also can include multiple host entries for the same server if each entry has a unique identifier (the combination of the IP address and UDP port number), allowing different ports to be individually defined as RADIUS hosts providing a specific AAA service. If you configure two different host entries on the same RADIUS server for the same service, (for example, accounting), the second configured host entry acts as a fail-over backup to the first one.

You use the **server** group server configuration command to associate a particular server with a defined group server. You can either identify the server by its IP address or identify multiple host instances or entries by using the optional **auth-port** and **acct-port** keywords.

Beginning in privileged EXEC mode, follow these steps to define the AAA server group and associate a particular RADIUS server with it:

	Command	Purpose
Step 1	configure terminal	Enter global configuration mode.
Step 2	radius-server host { <i>hostname</i> <i>ip-address</i> } [auth-port <i>port-number</i>] [acct-port <i>port-number</i>] [timeout <i>seconds</i>] [retransmit <i>retries</i>] [key <i>string</i>]	<p>Specify the IP address or hostname of the remote RADIUS server host.</p> <ul style="list-style-type: none"> (Optional) For auth-port <i>port-number</i>, specify the UDP destination port for authentication requests. (Optional) For acct-port <i>port-number</i>, specify the UDP destination port for accounting requests. (Optional) For timeout <i>seconds</i>, specify the time interval that the switch waits for the RADIUS server to reply before resending. The range is 1 to 1000. This setting overrides the radius-server timeout global configuration command setting. If no timeout is set with the radius-server host command, the setting of the radius-server timeout command is used. (Optional) For retransmit <i>retries</i>, specify the number of times a RADIUS request is resent to a server if that server is not responding or responding slowly. The range is 1 to 1000. If no retransmit value is set with the radius-server host command, the setting of the radius-server retransmit global configuration command is used. (Optional) For key <i>string</i>, specify the authentication and encryption key used between the switch and the RADIUS daemon running on the RADIUS server. <p>Note The key is a text string that must match the encryption key used on the RADIUS server. Always configure the key as the last item in the radius-server host command. Leading spaces are ignored, but spaces within and at the end of the key are used. If you use spaces in your key, do not enclose the key in quotation marks unless the quotation marks are part of the key.</p> <p>To configure the switch to recognize more than one host entry associated with a single IP address, enter this command as many times as necessary, making sure that each UDP port number is different. The switch software searches for hosts in the order in which you specify them. Set the timeout, retransmit, and encryption key values to use with the specific RADIUS host.</p>
Step 3	aaa new-model	Enable AAA.
Step 4	aaa group server radius <i>group-name</i>	Define the AAA server-group with a group name. This command puts the switch in a server group configuration mode.
Step 5	server <i>ip-address</i>	Associate a particular RADIUS server with the defined server group. Repeat this step for each RADIUS server in the AAA server group. Each server in the group must be previously defined in Step 2.
Step 6	end	Return to privileged EXEC mode.
Step 7	show running-config	Verify your entries.

	Command	Purpose
Step 8	<code>copy running-config startup-config</code>	(Optional) Save your entries in the configuration file.
Step 9		Enable RADIUS login authentication. See the “ Configuring RADIUS Login Authentication ” section on page 8-23.

To remove the specified RADIUS server, use the **no radius-server host** *hostname | ip-address* global configuration command. To remove a server group from the configuration list, use the **no aaa group server radius** *group-name* global configuration command. To remove the IP address of a RADIUS server, use the **no server ip-address** server group configuration command.

In this example, the switch is configured to recognize two different RADIUS group servers (*group1* and *group2*). Group1 has two different host entries on the same RADIUS server configured for the same services. The second host entry acts as a fail-over backup to the first entry.

```
Switch(config)# radius-server host 172.20.0.1 auth-port 1000 acct-port 1001
Switch(config)# radius-server host 172.10.0.1 auth-port 1645 acct-port 1646
Switch(config)# aaa new-model
Switch(config)# aaa group server radius group1
Switch(config-sg-radius)# server 172.20.0.1 auth-port 1000 acct-port 1001
Switch(config-sg-radius)# exit
Switch(config)# aaa group server radius group2
Switch(config-sg-radius)# server 172.20.0.1 auth-port 2000 acct-port 2001
Switch(config-sg-radius)# exit
```

Configuring RADIUS Authorization for User Privileged Access and Network Services

AAA authorization limits the services available to a user. When AAA authorization is enabled, the switch uses information retrieved from the user’s profile, which is in the local user database or on the security server, to configure the user’s session. The user is granted access to a requested service only if the information in the user profile allows it.

You can use the **aaa authorization** global configuration command with the **radius** keyword to set parameters that restrict a user’s network access to privileged EXEC mode.

The **aaa authorization exec radius local** command sets these authorization parameters:

- Use RADIUS for privileged EXEC access authorization if authentication was performed by using RADIUS.
- Use the local database if authentication was not performed by using RADIUS.



Note

Authorization is bypassed for authenticated users who log in through the CLI even if authorization has been configured.

Beginning in privileged EXEC mode, follow these steps to specify RADIUS authorization for privileged EXEC access and network services:

	Command	Purpose
Step 1	configure terminal	Enter global configuration mode.
Step 2	aaa authorization network radius	Configure the switch for user RADIUS authorization for all network-related service requests.
Step 3	aaa authorization exec radius	Configure the switch for user RADIUS authorization if the user has privileged EXEC access. The exec keyword might return user profile information (such as autocommand information).
Step 4	end	Return to privileged EXEC mode.
Step 5	show running-config	Verify your entries.
Step 6	copy running-config startup-config	(Optional) Save your entries in the configuration file.

To disable authorization, use the **no aaa authorization {network | exec} method1** global configuration command.

Starting RADIUS Accounting

The AAA accounting feature tracks the services that users are accessing and the amount of network resources that they are consuming. When AAA accounting is enabled, the switch reports user activity to the RADIUS security server in the form of accounting records. Each accounting record contains accounting attribute-value (AV) pairs and is stored on the security server. This data can then be analyzed for network management, client billing, or auditing.

Beginning in privileged EXEC mode, follow these steps to enable RADIUS accounting for each Cisco IOS privilege level and for network services:

	Command	Purpose
Step 1	configure terminal	Enter global configuration mode.
Step 2	aaa accounting network start-stop radius	Enable RADIUS accounting for all network-related service requests.
Step 3	aaa accounting exec start-stop radius	Enable RADIUS accounting to send a start-record accounting notice at the beginning of a privileged EXEC process and a stop-record at the end.
Step 4	end	Return to privileged EXEC mode.
Step 5	show running-config	Verify your entries.
Step 6	copy running-config startup-config	(Optional) Save your entries in the configuration file.

To disable accounting, use the **no aaa accounting {network | exec} {start-stop} method1...** global configuration command.

Configuring Settings for All RADIUS Servers

Beginning in privileged EXEC mode, follow these steps to configure global communication settings between the switch and all RADIUS servers:

	Command	Purpose
Step 1	<code>configure terminal</code>	Enter global configuration mode.
Step 2	<code>radius-server key <i>string</i></code>	Specify the shared secret text string used between the switch and all RADIUS servers. Note The key is a text string that must match the encryption key used on the RADIUS server. Leading spaces are ignored, but spaces within and at the end of the key are used. If you use spaces in your key, do not enclose the key in quotation marks unless the quotation marks are part of the key.
Step 3	<code>radius-server retransmit <i>retries</i></code>	Specify the number of times the switch sends each RADIUS request to the server before giving up. The default is 3; the range 1 to 1000.
Step 4	<code>radius-server timeout <i>seconds</i></code>	Specify the number of seconds a switch waits for a reply to a RADIUS request before resending the request. The default is 5 seconds; the range is 1 to 1000.
Step 5	<code>radius-server deadtime <i>minutes</i></code>	Specify the number of minutes a RADIUS server, which is not responding to authentication requests, to be skipped, thus avoiding the wait for the request to timeout before trying the next configured server. The default is 0; the range is 1 to 1440 minutes.
Step 6	<code>end</code>	Return to privileged EXEC mode.
Step 7	<code>show running-config</code>	Verify your settings.
Step 8	<code>copy running-config startup-config</code>	(Optional) Save your entries in the configuration file.

To return to the default setting for the retransmit, timeout, and deadtime, use the **no** forms of these commands.

Configuring the Switch to Use Vendor-Specific RADIUS Attributes

The Internet Engineering Task Force (IETF) draft standard specifies a method for communicating vendor-specific information between the switch and the RADIUS server by using the vendor-specific attribute (attribute 26). Vendor-specific attributes (VSAs) allow vendors to support their own extended attributes not suitable for general use. The Cisco RADIUS implementation supports one vendor-specific option by using the format recommended in the specification. Cisco's vendor-ID is 9, and the supported option has vendor-type 1, which is named *cisco-avpair*. The value is a string with this format:

```
protocol : attribute sep value *
```

Protocol is a value of the Cisco protocol attribute for a particular type of authorization. *Attribute* and *value* are an appropriate attribute-value (AV) pair defined in the Cisco TACACS+ specification, and *sep* is = for mandatory attributes and is * for optional attributes. The full set of features available for TACACS+ authorization can then be used for RADIUS.

For example, this AV pair activates Cisco's *multiple named ip address pools* feature during IP authorization (during PPP IPCP address assignment):

```
cisco-avpair= "ip:addr-pool=first"
```

This example shows how to provide a user logging in from a switch with immediate access to privileged EXEC commands:

```
cisco-avpair= "shell:priv-lvl=15"
```

This example shows how to specify an authorized VLAN in the RADIUS server database:

```
cisco-avpair= "tunnel-type(#64)=VLAN(13)"
cisco-avpair= "tunnel-medium-type(#65)=802 media(6)"
cisco-avpair= "tunnel-private-group-ID(#81)=vlanid"
```

This example shows how to apply an input ACL in ASCII format to an interface for the duration of this connection:

```
cisco-avpair= "ip:inacl#1=deny ip 10.10.10.10 0.0.255.255 20.20.20.20 255.255.0.0"
cisco-avpair= "ip:inacl#2=deny ip 10.10.10.10 0.0.255.255 any"
cisco-avpair= "mac:inacl#3=deny any any decnet-iv"
```

This example shows how to apply an output ACL in ASCII format to an interface for the duration of this connection:

```
cisco-avpair= "ip:outacl#2=deny ip 10.10.10.10 0.0.255.255 any"
```

Other vendors have their own unique vendor-IDs, options, and associated VSAs. For more information about vendor-IDs and VSAs, see RFC 2138, "Remote Authentication Dial-In User Service (RADIUS)."

Beginning in privileged EXEC mode, follow these steps to configure the switch to recognize and use VSAs:

	Command	Purpose
Step 1	<code>configure terminal</code>	Enter global configuration mode.
Step 2	<code>radius-server vsa send [accounting authentication]</code>	<p>Enable the switch to recognize and use VSAs as defined by RADIUS IETF attribute 26.</p> <ul style="list-style-type: none"> (Optional) Use the accounting keyword to limit the set of recognized vendor-specific attributes to only accounting attributes. (Optional) Use the authentication keyword to limit the set of recognized vendor-specific attributes to only authentication attributes. <p>If you enter this command without keywords, both accounting and authentication vendor-specific attributes are used.</p>
Step 3	<code>end</code>	Return to privileged EXEC mode.
Step 4	<code>show running-config</code>	Verify your settings.
Step 5	<code>copy running-config startup-config</code>	(Optional) Save your entries in the configuration file.



Note

For a complete list of RADIUS attributes or more information about vendor-specific attribute 26, see the "RADIUS Attributes" appendix in the *Cisco IOS Security Configuration Guide, Release 12.2* from the Cisco.com page under **Documentation > Cisco IOS Software > 12.2 Mainline > Command References**.

Configuring the Switch for Vendor-Proprietary RADIUS Server Communication

Although an IETF draft standard for RADIUS specifies a method for communicating vendor-proprietary information between the switch and the RADIUS server, some vendors have extended the RADIUS attribute set in a unique way. Cisco IOS software supports a subset of vendor-proprietary RADIUS attributes.

As mentioned earlier, to configure RADIUS (whether vendor-proprietary or IETF draft-compliant), you must specify the host running the RADIUS server daemon and the secret text string it shares with the switch. You specify the RADIUS host and secret text string by using the **radius-server** global configuration commands.

Beginning in privileged EXEC mode, follow these steps to specify a vendor-proprietary RADIUS server host and a shared secret text string:

	Command	Purpose
Step 1	configure terminal	Enter global configuration mode.
Step 2	radius-server host {hostname ip-address} non-standard	Specify the IP address or hostname of the remote RADIUS server host and identify that it is using a vendor-proprietary implementation of RADIUS.
Step 3	radius-server key string	Specify the shared secret text string used between the switch and the vendor-proprietary RADIUS server. The switch and the RADIUS server use this text string to encrypt passwords and exchange responses. Note The key is a text string that must match the encryption key used on the RADIUS server. Leading spaces are ignored, but spaces within and at the end of the key are used. If you use spaces in your key, do not enclose the key in quotation marks unless the quotation marks are part of the key.
Step 4	end	Return to privileged EXEC mode.
Step 5	show running-config	Verify your settings.
Step 6	copy running-config startup-config	(Optional) Save your entries in the configuration file.

To delete the vendor-proprietary RADIUS host, use the **no radius-server host** {hostname | ip-address} **non-standard** global configuration command. To disable the key, use the **no radius-server key** global configuration command.

This example shows how to specify a vendor-proprietary RADIUS host and to use a secret key of *rad124* between the switch and the server:

```
Switch(config)# radius-server host 172.20.30.15 nonstandard
Switch(config)# radius-server key rad124
```

Displaying the RADIUS Configuration

To display the RADIUS configuration, use the **show running-config** privileged EXEC command.

Configuring the Switch for Local Authentication and Authorization

You can configure AAA to operate without a server by setting the switch to implement AAA in local mode. The switch then handles authentication and authorization. No accounting is available in this configuration.

Beginning in privileged EXEC mode, follow these steps to configure the switch for local AAA:

	Command	Purpose
Step 1	<code>configure terminal</code>	Enter global configuration mode.
Step 2	<code>aaa new-model</code>	Enable AAA.
Step 3	<code>aaa authentication login default local</code>	Set the login authentication to use the local username database. The default keyword applies the local user database authentication to all ports.
Step 4	<code>aaa authorization exec local</code>	Configure user AAA authorization, check the local database, and allow the user to run an EXEC shell.
Step 5	<code>aaa authorization network local</code>	Configure user AAA authorization for all network-related service requests.
Step 6	<code>username name [privilege level] {password encryption-type password}</code>	Enter the local database, and establish a username-based authentication system. Repeat this command for each user. <ul style="list-style-type: none"> For <i>name</i>, specify the user ID as one word. Spaces and quotation marks are not allowed. (Optional) For <i>level</i>, specify the privilege level the user has after gaining access. The range is 0 to 15. Level 15 gives privileged EXEC mode access. Level 0 gives user EXEC mode access. For <i>encryption-type</i>, enter 0 to specify that an unencrypted password follows. Enter 7 to specify that a hidden password follows. For <i>password</i>, specify the password the user must enter to gain access to the switch. The password must be from 1 to 25 characters, can contain embedded spaces, and must be the last option specified in the username command.
Step 7	<code>end</code>	Return to privileged EXEC mode.
Step 8	<code>show running-config</code>	Verify your entries.
Step 9	<code>copy running-config startup-config</code>	(Optional) Save your entries in the configuration file.

To disable AAA, use the **no aaa new-model** global configuration command. To disable authorization, use the **no aaa authorization {network | exec} method1** global configuration command.

**Note**

To secure the switch for HTTP access by using AAA methods, you must configure the switch with the **ip http authentication aaa** global configuration command. Configuring AAA authentication does not secure the switch for HTTP access by using AAA methods.

For more information about the **ip http authentication** command, see the *Cisco IOS Security Command Reference, Release 12.2*.

Configuring the Switch for Secure Shell

This section describes how to configure the Secure Shell (SSH) feature. To use this feature, you must install the cryptographic (encrypted) software image on your switch. You must obtain authorization to use this feature and to download the cryptographic software files from Cisco.com. For more information, see the release notes for this release.

These sections contain this information:

- [Understanding SSH, page 8-33](#)
- [Configuring SSH, page 8-34](#)
- [Displaying the SSH Configuration and Status, page 8-37](#)

For SSH configuration examples, see the “SSH Configuration Examples” section in the “Configuring Secure Shell” chapter of the *Cisco IOS Security Configuration Guide, Cisco IOS Release 12.2*, at this URL:

http://www.cisco.com/en/US/products/sw/iosswrel/ps1835/products_configuration_guide_chapter09186a00800ca7d5.html

**Note**

For complete syntax and usage information for the commands used in this section, see the command reference for this release and the command reference for Cisco IOS Release 12.2 at this URL:

http://www.cisco.com/en/US/products/sw/iosswrel/ps1835/products_command_reference_book09186a0080087e33.html

Understanding SSH

SSH is a protocol that provides a secure, remote connection to a device. SSH provides more security for remote connections than Telnet does by providing strong encryption when a device is authenticated. This software release supports SSH Version 1 (SSHv1) and SSH Version 2 (SSHv2).

This section consists of these topics:

- [SSH Servers, Integrated Clients, and Supported Versions, page 8-33](#)
- [Limitations, page 8-34](#)

SSH Servers, Integrated Clients, and Supported Versions

The SSH feature has an SSH server and an SSH integrated client, which are applications that run on the switch. You can use an SSH client to connect to a switch running the SSH server. The SSH server works with the SSH client supported in this release and with non-Cisco SSH clients. The SSH client also works with the SSH server supported in this release and with non-Cisco SSH servers.

The switch supports an SSHv1 or an SSHv2 server.

The switch supports an SSHv1 client.

SSH supports the Data Encryption Standard (DES) encryption algorithm, the Triple DES (3DES) encryption algorithm, and password-based user authentication.

SSH also supports these user authentication methods:

- TACACS+ (for more information, see the [“Controlling Switch Access with TACACS+”](#) section on page 8-10)
- RADIUS (for more information, see the [“Controlling Switch Access with RADIUS”](#) section on page 8-17)
- Local authentication and authorization (for more information, see the [“Configuring the Switch for Local Authentication and Authorization”](#) section on page 8-32)



Note

This software release does not support IP Security (IPSec).

Limitations

These limitations apply to SSH:

- The switch supports Rivest, Shamir, and Adelman (RSA) authentication.
- SSH supports only the execution-shell application.
- The SSH server and the SSH client are supported only on DES (56-bit) and 3DES (168-bit) data encryption software.
- The switch does not support the Advanced Encryption Standard (AES) symmetric encryption algorithm.

Configuring SSH

This section has this configuration information:

- [Configuration Guidelines, page 8-34](#)
- [Setting Up the Switch to Run SSH, page 8-35](#) (required)
- [Configuring the SSH Server, page 8-36](#) (required only if you are configuring the switch as an SSH server)

Configuration Guidelines

Follow these guidelines when configuring the switch as an SSH server or SSH client:

- An RSA key pair generated by a SSHv1 server can be used by an SSHv2 server, and the reverse.
- If you get CLI error messages after entering the **crypto key generate rsa** global configuration command, an RSA key pair has not been generated. Reconfigure the hostname and domain, and then enter the **crypto key generate rsa** command. For more information, see the [“Setting Up the Switch to Run SSH”](#) section on page 8-35.
- When generating the RSA key pair, the message `No host name specified` might appear. If it does, you must configure a hostname by using the **hostname** global configuration command.

- When generating the RSA key pair, the message `No domain specified` might appear. If it does, you must configure an IP domain name by using the **ip domain-name** global configuration command.
- When configuring the local authentication and authorization authentication method, make sure that AAA is disabled on the console.

Setting Up the Switch to Run SSH

Follow these steps to set up your switch to run SSH:

1. Download the cryptographic software image from Cisco.com. This step is required. For more information, see the release notes for this release.
2. Configure a hostname and IP domain name for the switch. Follow this procedure only if you are configuring the switch as an SSH server.
3. Generate an RSA key pair for the switch, which automatically enables SSH. Follow this procedure only if you are configuring the switch as an SSH server.
4. Configure user authentication for local or remote access. This step is required. For more information, see the [“Configuring the Switch for Local Authentication and Authorization” section on page 8-32](#).

Beginning in privileged EXEC mode, follow these steps to configure a hostname and an IP domain name and to generate an RSA key pair. This procedure is required if you are configuring the switch as an SSH server.

	Command	Purpose
Step 1	configure terminal	Enter global configuration mode.
Step 2	hostname <i>hostname</i>	Configure a hostname for your switch.
Step 3	ip domain-name <i>domain_name</i>	Configure a host domain for your switch.
Step 4	crypto key generate rsa	Enable the SSH server for local and remote authentication on the switch and generate an RSA key pair. We recommend that a minimum modulus size of 1024 bits. When you generate RSA keys, you are prompted to enter a modulus length. A longer modulus length might be more secure, but it takes longer to generate and to use.
Step 5	end	Return to privileged EXEC mode.
Step 6	show ip ssh or show ssh	Show the version and configuration information for your SSH server. Show the status of the SSH server on the switch.
Step 7	copy running-config startup-config	(Optional) Save your entries in the configuration file.

To delete the RSA key pair, use the **crypto key zeroize rsa** global configuration command. After the RSA key pair is deleted, the SSH server is automatically disabled.

Configuring the SSH Server

Beginning in privileged EXEC mode, follow these steps to configure the SSH server:

	Command	Purpose
Step 1	configure terminal	Enter global configuration mode.
Step 2	ip ssh version [1 2]	<p>(Optional) Configure the switch to run SSH Version 1 or SSH Version 2.</p> <ul style="list-style-type: none"> • 1—Configure the switch to run SSH Version 1. • 2—Configure the switch to run SSH Version 2. <p>If you do not enter this command or do not specify a keyword, the SSH server selects the latest SSH version supported by the SSH client. For example, if the SSH client supports SSHv1 and SSHv2, the SSH server selects SSHv2.</p>
Step 3	ip ssh { timeout <i>seconds</i> authentication-retries <i>number</i> }	<p>Configure the SSH control parameters:</p> <ul style="list-style-type: none"> • Specify the time-out value in seconds; the default is 120 seconds. The range is 0 to 120 seconds. This parameter applies to the SSH negotiation phase. After the connection is established, the switch uses the default time-out values of the CLI-based sessions. <p>By default, up to five simultaneous, encrypted SSH connections for multiple CLI-based sessions over the network are available (session 0 to session 4). After the execution shell starts, the CLI-based session time-out value returns to the default of 10 minutes.</p> <ul style="list-style-type: none"> • Specify the number of times that a client can re-authenticate to the server. The default is 3; the range is 0 to 5. <p>Repeat this step when configuring both parameters.</p>
Step 4	line vty <i>line_number</i> [ending_line_number] transport input ssh	<p>(Optional) Configure the virtual terminal line settings.</p> <ul style="list-style-type: none"> • Enter line configuration mode to configure the virtual terminal line settings. For <i>line_number</i> and <i>ending_line_number</i>, specify a pair of lines. The range is 0 to 15. • Specify that the switch prevent non-SSH Telnet connections. This limits the router to only SSH connections.
Step 5	end	Return to privileged EXEC mode.
Step 6	show ip ssh or show ssh	<p>Show the version and configuration information for your SSH server.</p> <p>Show the status of the SSH server connections on the switch.</p>
Step 7	copy running-config startup-config	(Optional) Save your entries in the configuration file.

To return to the default SSH control parameters, use the **no ip ssh { timeout | authentication-retries }** global configuration command.

Displaying the SSH Configuration and Status

To display the SSH server configuration and status, use one or more of the privileged EXEC commands in [Table 8-2](#):

Table 8-2 Commands for Displaying the SSH Server Configuration and Status

Command	Purpose
<code>show ip ssh</code>	Shows the version and configuration information for the SSH server.
<code>show ssh</code>	Shows the status of the SSH server.

For more information about these commands, see the “Secure Shell Commands” section in the “Other Security Features” chapter of the *Cisco IOS Security Command Reference, Cisco IOS Release 12.2*, at this URL:

http://www.cisco.com/en/US/products/sw/iosswrel/ps1835/products_command_reference_chapter09186a00800ca7cd.html

Configuring the Switch for Secure Socket Layer HTTP

This section describes how to configure Secure Socket Layer (SSL) version 3.0 support for the HTTP 1.1 server and client. SSL provides server authentication, encryption, and message integrity, as well as HTTP client authentication, to allow secure HTTP communications. To use this feature, the cryptographic (encrypted) software image must be installed on your switch. You must obtain authorization to use this feature and to download the cryptographic software files from Cisco.com. For more information about the crypto image, see the release notes for this release.

These sections contain this information:

- [Understanding Secure HTTP Servers and Clients, page 8-37](#)
- [Configuring Secure HTTP Servers and Clients, page 8-40](#)
- [Displaying Secure HTTP Server and Client Status, page 8-43](#)

For configuration examples and complete syntax and usage information for the commands used in this section, see the “HTTPS - HTTP Server and Client with SSL 3.0” feature description for Cisco IOS Release 12.2(15)T at this URL:

http://www.cisco.com/en/US/products/sw/iosswrel/ps1839/products_feature_guide09186a008015a4c6.html

Understanding Secure HTTP Servers and Clients

On a secure HTTP connection, data to and from an HTTP server is encrypted before being sent over the Internet. HTTP with SSL encryption provides a secure connection to allow such functions as configuring a switch from a Web browser. Cisco's implementation of the secure HTTP server and secure HTTP client uses an implementation of SSL Version 3.0 with application-layer encryption. HTTP over SSL is abbreviated as HTTPS; the URL of a secure connection begins with `https://` instead of `http://`.

The primary role of the HTTP secure server (the switch) is to listen for HTTPS requests on a designated port (the default HTTPS port is 443) and pass the request to the HTTP 1.1 Web server. The HTTP 1.1 server processes requests and passes responses (pages) back to the HTTP secure server, which, in turn, responds to the original request.

The primary role of the HTTP secure client (the web browser) is to respond to Cisco IOS application requests for HTTPS User Agent services, perform HTTPS User Agent services for the application, and pass the response back to the application.

Certificate Authority Trustpoints

Certificate authorities (CAs) manage certificate requests and issue certificates to participating network devices. These services provide centralized security key and certificate management for the participating devices. Specific CA servers are referred to as *trustpoints*.

When a connection attempt is made, the HTTPS server provides a secure connection by issuing a certified X.509v3 certificate, obtained from a specified CA trustpoint, to the client. The client (usually a Web browser), in turn, has a public key that allows it to authenticate the certificate.

For secure HTTP connections, we highly recommend that you configure a CA trustpoint. If a CA trustpoint is not configured for the device running the HTTPS server, the server certifies itself and generates the needed RSA key pair. Because a self-certified (self-signed) certificate does not provide adequate security, the connecting client generates a notification that the certificate is self-certified, and the user has the opportunity to accept or reject the connection. This option is useful for internal network topologies (such as testing).

If you do not configure a CA trustpoint, when you enable a secure HTTP connection, either a temporary or a persistent self-signed certificate for the secure HTTP server (or client) is automatically generated.

- If the switch is not configured with a hostname and a domain name, a temporary self-signed certificate is generated. If the switch reboots, any temporary self-signed certificate is lost, and a new temporary new self-signed certificate is assigned.
- If the switch has been configured with a host and domain name, a persistent self-signed certificate is generated. This certificate remains active if you reboot the switch or if you disable the secure HTTP server so that it will be there the next time you re-enable a secure HTTP connection.

If a self-signed certificate has been generated, this information is included in the output of the **show running-config** privileged EXEC command. This is a partial sample output from that command displaying a self-signed certificate.

```
Switch# show running-config
Building configuration...

<output truncated>

crypto pki trustpoint TP-self-signed-3080755072
  enrollment selfsigned
  subject-name cn=IOS-Self-Signed-Certificate-3080755072
  revocation-check none
  rsakeypair TP-self-signed-3080755072
!
```

```
crypto ca certificate chain TP-self-signed-3080755072
certificate self-signed 01
 3082029F 30820208 A0030201 02020101 300D0609 2A864886 F70D0101 04050030
59312F30 2D060355 04031326 494F532D 53656C66 2D536967 6E65642D 43657274
69666963 6174652D 33303830 37353530 37323126 30240609 2A864886 F70D0109
02161743 45322D33 3535302D 31332E73 756D6D30 342D3335 3530301E 170D3933
30333031 30303030 35395A17 0D323030 31303130 30303030 305A3059 312F302D
```

<output truncated>

You can remove this self-signed certificate by disabling the secure HTTP server and entering the **no crypto pki trustpoint TP-self-signed-30890755072** global configuration command. If you later re-enable a secure HTTP server, a new self-signed certificate is generated.



Note

The values that follow *TP self-signed* depend on the serial number of the device.

You can use an optional command (**ip http secure-client-auth**) to allow the HTTPS server to request an X.509v3 certificate from the client. Authenticating the client provides more security than server authentication by itself.

For additional information on Certificate Authorities, see the “Configuring Certification Authority Interoperability” chapter in the *Cisco IOS Security Configuration Guide, Release 12.2* from the Cisco.com page under **Documentation > Cisco IOS Software > 12.2 Mainline > Command References**.

CipherSuites

A CipherSuite specifies the encryption algorithm and the digest algorithm to use on a SSL connection. When connecting to the HTTPS server, the client Web browser offers a list of supported CipherSuites, and the client and server negotiate the best encryption algorithm to use from those on the list that are supported by both. For example, Netscape Communicator 4.76 supports U.S. security with RSA Public Key Cryptography, MD2, MD5, RC2-CBC, RC4, DES-CBC, and DES-EDE3-CBC.

For the best possible encryption, you should use a client browser that supports 128-bit encryption, such as Microsoft Internet Explorer Version 5.5 (or later) or Netscape Communicator Version 4.76 (or later). The SSL_RSA_WITH_DES_CBC_SHA CipherSuite provides less security than the other CipherSuites, as it does not offer 128-bit encryption.

The more secure and more complex CipherSuites require slightly more processing time. This list defines the CipherSuites supported by the switch and ranks them from fastest to slowest in terms of router processing load (speed):

1. SSL_RSA_WITH_DES_CBC_SHA—RSA key exchange (RSA Public Key Cryptography) with DES-CBC for message encryption and SHA for message digest
2. SSL_RSA_WITH_RC4_128_MD5—RSA key exchange with RC4 128-bit encryption and MD5 for message digest
3. SSL_RSA_WITH_RC4_128_SHA—RSA key exchange with RC4 128-bit encryption and SHA for message digest
4. SSL_RSA_WITH_3DES_EDE_CBC_SHA—RSA key exchange with 3DES and DES-EDE3-CBC for message encryption and SHA for message digest

RSA (in conjunction with the specified encryption and digest algorithm combinations) is used for both key generation and authentication on SSL connections. This usage is independent of whether or not a CA trustpoint is configured.

Configuring Secure HTTP Servers and Clients

These sections contain this configuration information:

- [Default SSL Configuration, page 8-40](#)
- [SSL Configuration Guidelines, page 8-40](#)
- [Configuring a CA Trustpoint, page 8-40](#)
- [Configuring the Secure HTTP Server, page 8-41](#)
- [Configuring the Secure HTTP Client, page 8-43](#)

Default SSL Configuration

The standard HTTP server is enabled.

SSL is enabled.

No CA trustpoints are configured.

No self-signed certificates are generated.

SSL Configuration Guidelines

When SSL is used in a switch cluster, the SSL session terminates at the cluster commander. Cluster member switches must run standard HTTP.

Before you configure a CA trustpoint, you should ensure that the system clock is set. If the clock is not set, the certificate is rejected due to an incorrect date.

Configuring a CA Trustpoint

For secure HTTP connections, we recommend that you configure an official CA trustpoint. A CA trustpoint is more secure than a self-signed certificate.

Beginning in privileged EXEC mode, follow these steps to configure a CA trustpoint:

	Command	Purpose
Step 1	configure terminal	Enter global configuration mode.
Step 2	hostname <i>hostname</i>	Specify the hostname of the switch (required only if you have not previously configured a hostname). The hostname is required for security keys and certificates.
Step 3	ip domain-name <i>domain-name</i>	Specify the IP domain name of the switch (required only if you have not previously configured an IP domain name). The domain name is required for security keys and certificates.
Step 4	crypto key generate rsa	(Optional) Generate an RSA key pair. RSA key pairs are required before you can obtain a certificate for the switch. RSA key pairs are generated automatically. You can use this command to regenerate the keys, if needed.
Step 5	crypto ca trustpoint <i>name</i>	Specify a local configuration name for the CA trustpoint and enter CA trustpoint configuration mode.
Step 6	enrollment url <i>url</i>	Specify the URL to which the switch should send certificate requests.

	Command	Purpose
Step 7	enrollment http-proxy <i>host-name</i> <i>port-number</i>	(Optional) Configure the switch to obtain certificates from the CA through an HTTP proxy server.
Step 8	crl query <i>url</i>	Configure the switch to request a certificate revocation list (CRL) to ensure that the certificate of the peer has not been revoked.
Step 9	primary	(Optional) Specify that the trustpoint should be used as the primary (default) trustpoint for CA requests.
Step 10	exit	Exit CA trustpoint configuration mode and return to global configuration mode.
Step 11	crypto ca authentication <i>name</i>	Authenticate the CA by getting the public key of the CA. Use the same name used in Step 5.
Step 12	crypto ca enroll <i>name</i>	Obtain the certificate from the specified CA trustpoint. This command requests a signed certificate for each RSA key pair.
Step 13	end	Return to privileged EXEC mode.
Step 14	show crypto ca trustpoints	Verify the configuration.
Step 15	copy running-config startup-config	(Optional) Save your entries in the configuration file.

Use the **no crypto ca trustpoint** *name* global configuration command to delete all identity information and certificates associated with the CA.

Configuring the Secure HTTP Server

If you are using a certificate authority for certification, you should use the previous procedure to configure the CA trustpoint on the switch before enabling the HTTP server. If you have not configured a CA trustpoint, a self-signed certificate is generated the first time that you enable the secure HTTP server. After you have configured the server, you can configure options (path, access list to apply, maximum number of connections, or timeout policy) that apply to both standard and secure HTTP servers.

Beginning in privileged EXEC mode, follow these steps to configure a secure HTTP server:

	Command	Purpose
Step 1	show ip http server status	(Optional) Display the status of the HTTP server to determine if the secure HTTP server feature is supported in the software. You should see one of these lines in the output: HTTP secure server capability: Present or HTTP secure server capability: Not present
Step 2	configure terminal	Enter global configuration mode.
Step 3	ip http secure-server	Enable the HTTPS server if it has been disabled. The HTTPS server is enabled by default.
Step 4	ip http secure-port <i>port-number</i>	(Optional) Specify the port number to be used for the HTTPS server. The default port number is 443. Valid options are 443 or any number in the range 1025 to 65535.

	Command	Purpose
Step 5	ip http secure-ciphersuite { [3des-ede-cbc-sha] [rc4-128-md5] [rc4-128-sha] [des-cbc-sha]}	(Optional) Specify the CipherSuites (encryption algorithms) to be used for encryption over the HTTPS connection. If you do not have a reason to specify a particularly CipherSuite, you should allow the server and client to negotiate a CipherSuite that they both support. This is the default.
Step 6	ip http secure-client-auth	(Optional) Configure the HTTP server to request an X.509v3 certificate from the client for authentication during the connection process. The default is for the client to request a certificate from the server, but the server does not attempt to authenticate the client.
Step 7	ip http secure-trustpoint <i>name</i>	Specify the CA trustpoint to use to get an X.509v3 security certificate and to authenticate the client certificate connection. Note Use of this command assumes you have already configured a CA trustpoint according to the previous procedure.
Step 8	ip http path <i>path-name</i>	(Optional) Set a base HTTP path for HTML files. The path specifies the location of the HTTP server files on the local system (usually located in system flash memory).
Step 9	ip http access-class <i>access-list-number</i>	(Optional) Specify an access list to use to allow access to the HTTP server.
Step 10	ip http max-connections <i>value</i>	(Optional) Set the maximum number of concurrent connections that are allowed to the HTTP server. The range is 1 to 16; the default value is 5.
Step 11	ip http timeout-policy <i>idle seconds life seconds requests value</i>	(Optional) Specify how long a connection to the HTTP server can remain open under the defined circumstances: <ul style="list-style-type: none"> idle—the maximum time period when no data is received or response data cannot be sent. The range is 1 to 600 seconds. The default is 180 seconds (3 minutes). life—the maximum time period from the time that the connection is established. The range is 1 to 86400 seconds (24 hours). The default is 180 seconds. requests—the maximum number of requests processed on a persistent connection. The maximum value is 86400. The default is 1.
Step 12	end	Return to privileged EXEC mode.
Step 13	show ip http server secure status	Display the status of the HTTP secure server to verify the configuration.
Step 14	copy running-config startup-config	(Optional) Save your entries in the configuration file.

Use the **no ip http server** global configuration command to disable the standard HTTP server. Use the **no ip http secure-server** global configuration command to disable the secure HTTP server. Use the **no ip http secure-port** and the **no ip http secure-ciphersuite** global configuration commands to return to the default settings. Use the **no ip http secure-client-auth** global configuration command to remove the requirement for client authentication.

To verify the secure HTTP connection by using a Web browser, enter `https://URL`, where the URL is the IP address or hostname of the server switch. If you configure a port other than the default port, you must also specify the port number after the URL. For example:

```
https://209.165.129:1026
```

or

```
https://host.domain.com:1026
```

Configuring the Secure HTTP Client

The standard HTTP client and secure HTTP client are always enabled. A certificate authority is required for secure HTTP client certification. This procedure assumes that you have previously configured a CA trustpoint on the switch. If a CA trustpoint is not configured and the remote HTTPS server requires client authentication, connections to the secure HTTP client fail.

Beginning in privileged EXEC mode, follow these steps to configure a secure HTTP client:

	Command	Purpose
Step 1	configure terminal	Enter global configuration mode.
Step 2	ip http client secure-trustpoint <i>name</i>	(Optional) Specify the CA trustpoint to be used if the remote HTTP server requests client authentication. Using this command assumes that you have already configured a CA trustpoint by using the previous procedure. The command is optional if client authentication is not needed or if a primary trustpoint has been configured.
Step 3	ip http client secure-ciphersuite { [3des-ede-cbc-sha] [rc4-128-md5] [rc4-128-sha] [des-cbc-sha] }	(Optional) Specify the CipherSuites (encryption algorithms) to be used for encryption over the HTTPS connection. If you do not have a reason to specify a particular CipherSuite, you should allow the server and client to negotiate a CipherSuite that they both support. This is the default.
Step 4	end	Return to privileged EXEC mode.
Step 5	show ip http client secure status	Display the status of the HTTP secure server to verify the configuration.
Step 6	copy running-config startup-config	(Optional) Save your entries in the configuration file.

Use the **no ip http client secure-trustpoint *name*** to remove a client trustpoint configuration. Use the **no ip http client secure-ciphersuite** to remove a previously configured CipherSuite specification for the client.

Displaying Secure HTTP Server and Client Status

To display the SSL secure server and client status, use the privileged EXEC commands in [Table 8-3](#):

Table 8-3 Commands for Displaying the SSL Secure Server and Client Status

Command	Purpose
show ip http client secure status	Shows the HTTP secure client configuration.
show ip http server secure status	Shows the HTTP secure server configuration.
show running-config	Shows the generated self-signed certificate for secure HTTP connections.

Configuring the Switch for Secure Copy Protocol

The Secure Copy Protocol (SCP) feature provides a secure and authenticated method for copying switch configurations or switch image files. SCP relies on Secure Shell (SSH), an application and a protocol that provides a secure replacement for the Berkeley r-tools.

For SSH to work, the switch needs an RSA public/private key pair. This is the same with SCP, which relies on SSH for its secure transport.

Because SSH also relies on AAA authentication, and SCP relies further on AAA authorization, correct configuration is necessary.

- Before enabling SCP, you must correctly configure SSH, authentication, and authorization on the switch.
- Because SCP relies on SSH for its secure transport, the router must have an Rivest, Shamir, and Adelman (RSA) key pair.

**Note**

When using SCP, you cannot enter the password into the copy command. You must enter the password when prompted.

Information About Secure Copy

To configure Secure Copy feature, you should understand these concepts.

The behavior of SCP is similar to that of remote copy (rcp), which comes from the Berkeley r-tools suite, except that SCP relies on SSH for security. SCP also requires that authentication, authorization, and accounting (AAA) authorization be configured so the router can determine whether the user has the correct privilege level.

A user who has appropriate authorization can use SCP to copy any file in the Cisco IOS File System (IFS) to and from a switch by using the **copy** command. An authorized administrator can also do this from a workstation.

For more information on how to configure and verify SCP, see the “Secure Copy Protocol” chapter of the *Cisco IOS New Features, Cisco IOS Release 12.2*, at this URL:

http://www.cisco.com/en/US/products/sw/iosswrel/ps1839/products_feature_guide09186a0080087b18.html



CHAPTER 9

Configuring IEEE 802.1x Port-Based Authentication

This chapter describes how to configure IEEE 802.1x port-based authentication on the Catalyst 2960 switch. IEEE 802.1x authentication prevents unauthorized devices (clients) from gaining access to the network.



Note

For complete syntax and usage information for the commands used in this chapter, see the command reference for this release and the “RADIUS Commands” section in the *Cisco IOS Security Command Reference, Release 12.2* from the Cisco.com page under **Documentation > Cisco IOS Software > 12.2 Mainline > Command References**.

This chapter consists of these sections:

- [Understanding IEEE 802.1x Port-Based Authentication, page 9-1](#)
- [Configuring IEEE 802.1x Authentication, page 9-18](#)
- [Displaying IEEE 802.1x Statistics and Status, page 9-41](#)

Understanding IEEE 802.1x Port-Based Authentication

The IEEE 802.1x standard defines a client-server-based access control and authentication protocol that prevents clients from connecting to a LAN through publicly accessible ports unless they are authenticated. The authentication server authenticates each client connected to a switch port before making available any services offered by the switch or the LAN.

Until the client is authenticated, IEEE 802.1x access control allows only Extensible Authentication Protocol over LAN (EAPOL), Cisco Discovery Protocol (CDP), and Spanning Tree Protocol (STP) traffic through the port to which the client is connected. After authentication, normal traffic can pass through the port.

These sections describe IEEE 802.1x port-based authentication:

- [Device Roles, page 9-2](#)
- [Authentication Process, page 9-3](#)
- [Authentication Initiation and Message Exchange, page 9-5](#)
- [Ports in Authorized and Unauthorized States, page 9-7](#)
- [IEEE 802.1x Host Mode, page 9-7](#)

- IEEE 802.1x Accounting, page 9-8
- IEEE 802.1x Accounting Attribute-Value Pairs, page 9-8
- Using IEEE 802.1x Authentication with VLAN Assignment, page 9-9
- Using IEEE 802.1x Authentication with Guest VLAN, page 9-11
- Using IEEE 802.1x Authentication with Restricted VLAN, page 9-12
- Using IEEE 802.1x Authentication with Inaccessible Authentication Bypass, page 9-13
- Using IEEE 802.1x Authentication with Voice VLAN Ports, page 9-14
- Using IEEE 802.1x Authentication with Port Security, page 9-14
- Using IEEE 802.1x Authentication with Wake-on-LAN, page 9-15
- Using IEEE 802.1x Authentication with MAC Authentication Bypass, page 9-16
- Using Network Admission Control Layer 2 IEEE 802.1x Validation, page 9-17
- Using Web Authentication, page 9-17

Device Roles

With IEEE 802.1x port-based authentication, the devices in the network have specific roles, as shown in Figure 9-1.

Figure 9-1 IEEE 802.1x Device Roles

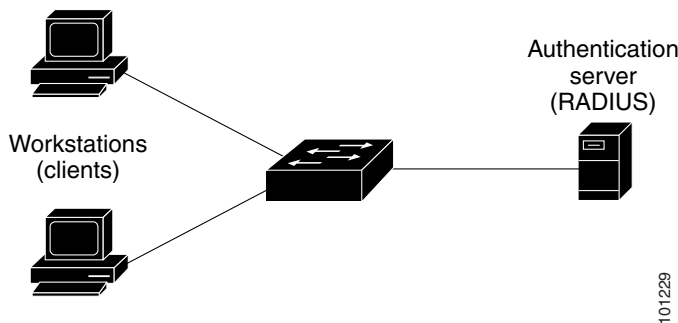

- *Client*—the device (workstation) that requests access to the LAN and switch services and responds to requests from the switch. The workstation must be running IEEE 802.1x-compliant client software such as that offered in the Microsoft Windows XP operating system. (The client is the *supplicant* in the IEEE 802.1x standard.)



Note To resolve Windows XP network connectivity and IEEE 802.1x authentication issues, read the Microsoft Knowledge Base article at this URL:

<http://support.microsoft.com/support/kb/articles/Q303/5/97.ASP>

- *Authentication server*—performs the actual authentication of the client. The authentication server validates the identity of the client and notifies the switch whether or not the client is authorized to access the LAN and switch services. Because the switch acts as the proxy, the authentication service is transparent to the client. In this release, the RADIUS security system with Extensible Authentication Protocol (EAP) extensions is the only supported authentication server. It is available

in Cisco Secure Access Control Server Version 3.0 or later. RADIUS operates in a client/server model in which secure authentication information is exchanged between the RADIUS server and one or more RADIUS clients.

- *Switch* (edge switch or wireless access point)—controls the physical access to the network based on the authentication status of the client. The switch acts as an intermediary (proxy) between the client and the authentication server, requesting identity information from the client, verifying that information with the authentication server, and relaying a response to the client. The switch includes the RADIUS client, which is responsible for encapsulating and decapsulating the EAP frames and interacting with the authentication server. (The switch is the *authenticator* in the IEEE 802.1x standard.)

When the switch receives EAPOL frames and relays them to the authentication server, the Ethernet header is stripped, and the remaining EAP frame is re-encapsulated in the RADIUS format. The EAP frames are not modified during encapsulation, and the authentication server must support EAP within the native frame format. When the switch receives frames from the authentication server, the server's frame header is removed, leaving the EAP frame, which is then encapsulated for Ethernet and sent to the client.

The devices that can act as intermediaries include the Catalyst 3750-E, Catalyst 3560-E, Catalyst 3750, Catalyst 3560, Catalyst 3550, Catalyst 2970, Catalyst 2960, Catalyst 2955, Catalyst 2950, Catalyst 2940 switches, or a wireless access point. These devices must be running software that supports the RADIUS client and IEEE 802.1x authentication.

Authentication Process

When IEEE 802.1x port-based authentication is enabled and the client supports IEEE 802.1x-compliant client software, these events occur:

- If the client identity is valid and the IEEE 802.1x authentication succeeds, the switch grants the client access to the network.
- If IEEE 802.1x authentication times out while waiting for an EAPOL message exchange and MAC authentication bypass is enabled, the switch can use the client MAC address for authorization. If the client MAC address is valid and the authorization succeeds, the switch grants the client access to the network. If the client MAC address is invalid and the authorization fails, the switch assigns the client to a guest VLAN that provides limited services if a guest VLAN is configured.
- If the switch gets an invalid identity from an IEEE 802.1x-capable client and a restricted VLAN is specified, the switch can assign the client to a restricted VLAN that provides limited services.
- If the RADIUS authentication server is unavailable (down) and inaccessible authentication bypass is enabled, the switch grants the client access to the network by putting the port in the critical-authentication state in the RADIUS-configured or the user-specified access VLAN.



Note

Inaccessible authentication bypass is also referred to as critical authentication or the AAA fail policy.

Figure 9-2 shows the authentication process.

Figure 9-2 Authentication Flowchart

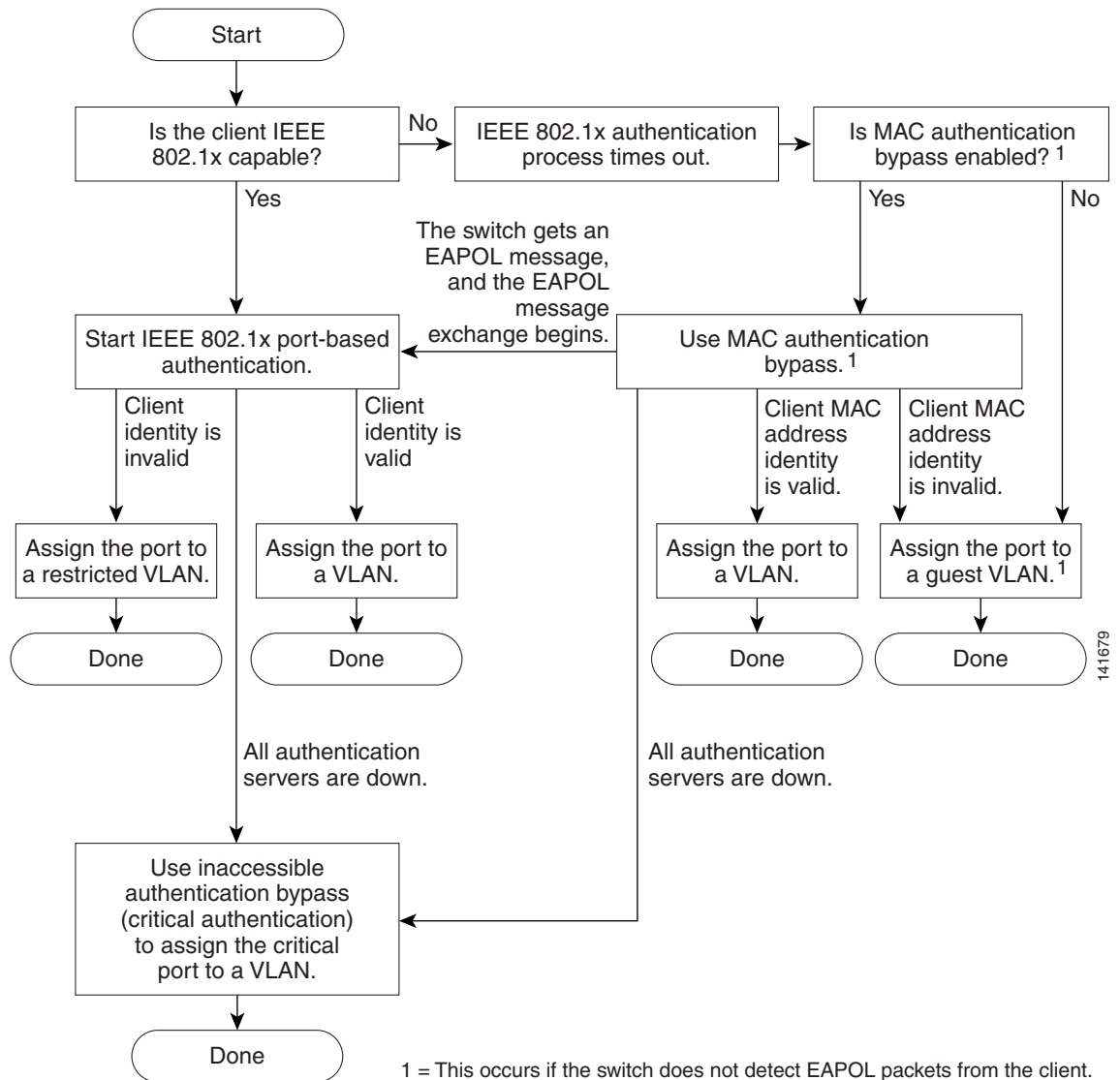

The switch re-authenticates a client when one of these situations occurs:

- Periodic re-authentication is enabled, and the re-authentication timer expires.

You can configure the re-authentication timer to use a switch-specific value or to be based on values from the RADIUS server.

After IEEE 802.1x authentication using a RADIUS server is configured, the switch uses timers based on the Session-Timeout RADIUS attribute (Attribute[27]) and the Termination-Action RADIUS attribute (Attribute [29]).

The Session-Timeout RADIUS attribute (Attribute[27]) specifies the time after which re-authentication occurs.

The Termination-Action RADIUS attribute (Attribute [29]) specifies the action to take during re-authentication. The actions are *Initialize* and *ReAuthenticate*. When the *Initialize* action is set (the attribute value is *DEFAULT*), the IEEE 802.1x session ends, and connectivity is lost during re-authentication. When the *ReAuthenticate* action is set (the attribute value is RADIUS-Request), the session is not affected during re-authentication.

- You manually re-authenticate the client by entering the **dot1x re-authenticate interface interface-id** privileged EXEC command.

Authentication Initiation and Message Exchange

During IEEE 802.1x authentication, the switch or the client can initiate authentication. If you enable authentication on a port by using the **dot1x port-control auto** interface configuration command, the switch initiates authentication when the link state changes from down to up or periodically as long as the port remains up and unauthenticated. The switch sends an EAP-request/identity frame to the client to request its identity. Upon receipt of the frame, the client responds with an EAP-response/identity frame.

However, if during boot up, the client does not receive an EAP-request/identity frame from the switch, the client can initiate authentication by sending an EAPOL-start frame, which prompts the switch to request the client's identity.



Note

If IEEE 802.1x authentication is not enabled or supported on the network access device, any EAPOL frames from the client are dropped. If the client does not receive an EAP-request/identity frame after three attempts to start authentication, the client sends frames as if the port is in the authorized state. A port in the authorized state effectively means that the client has been successfully authenticated. For more information, see the [“Ports in Authorized and Unauthorized States”](#) section on page 9-7.

When the client supplies its identity, the switch begins its role as the intermediary, passing EAP frames between the client and the authentication server until authentication succeeds or fails. If the authentication succeeds, the switch port becomes authorized. If the authentication fails, authentication can be retried, the port might be assigned to a VLAN that provides limited services, or network access is not granted. For more information, see the [“Ports in Authorized and Unauthorized States”](#) section on page 9-7.

The specific exchange of EAP frames depends on the authentication method being used. [Figure 9-3](#) shows a message exchange initiated by the client when the client uses the One-Time-Password (OTP) authentication method with a RADIUS server.

Figure 9-3 Message Exchange

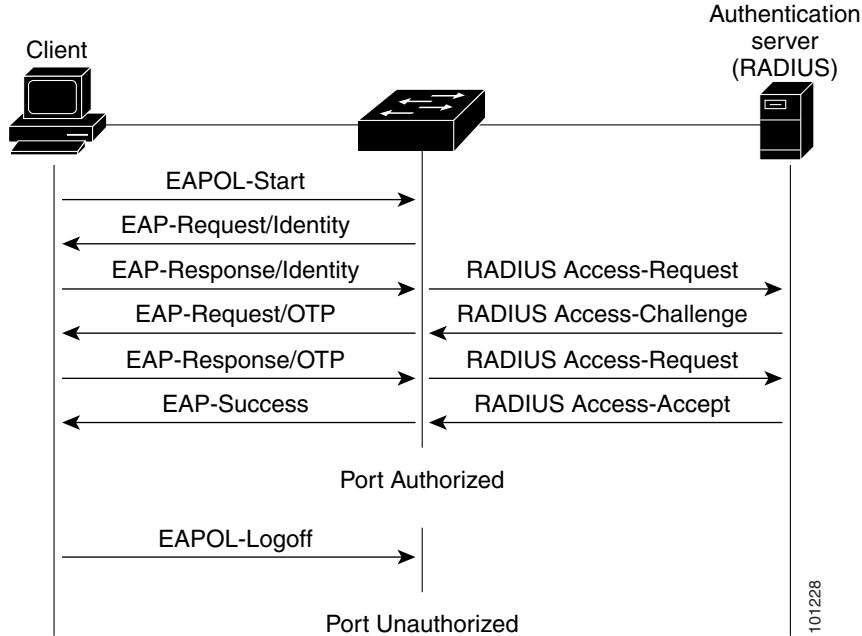

If IEEE 802.1x authentication times out while waiting for an EAPOL message exchange and MAC authentication bypass is enabled, the switch can authorize the client when the switch detects an Ethernet packet from the client. The switch uses the MAC address of the client as its identity and includes this information in the RADIUS-access/request frame that is sent to the RADIUS server. After the server sends the switch the RADIUS-access/accept frame (authorization is successful), the port becomes authorized. If authorization fails and a guest VLAN is specified, the switch assigns the port to the guest VLAN. If the switch detects an EAPOL packet while waiting for an Ethernet packet, the switch stops the MAC authentication bypass process and stops IEEE 802.1x authentication.

Figure 9-4 shows the message exchange during MAC authentication bypass.

Figure 9-4 Message Exchange During MAC Authentication Bypass

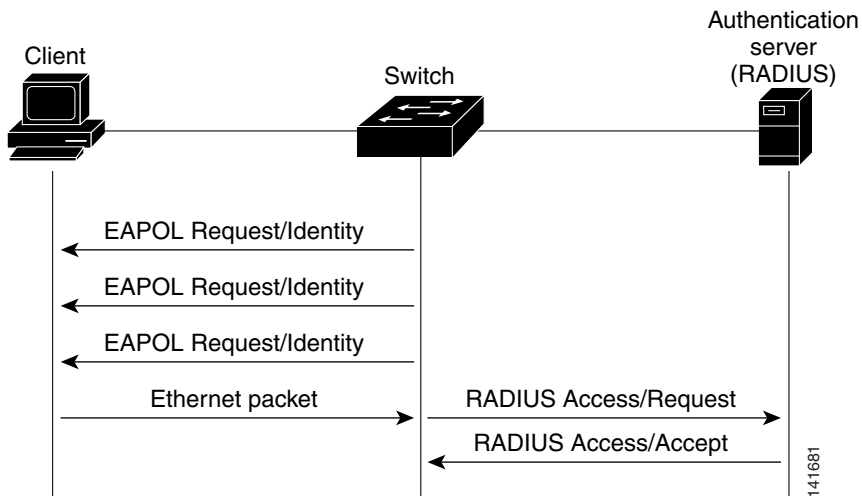

Ports in Authorized and Unauthorized States

During IEEE 802.1x authentication, depending on the switch port state, the switch can grant a client access to the network. The port starts in the *unauthorized* state. While in this state, the port that is not configured as a voice VLAN port disallows all ingress and egress traffic except for IEEE 802.1x authentication, CDP, and STP packets. When a client is successfully authenticated, the port changes to the *authorized* state, allowing all traffic for the client to flow normally. If the port is configured as a voice VLAN port, the port allows VoIP traffic and IEEE 802.1x protocol packets before the client is successfully authenticated.

If a client that does not support IEEE 802.1x authentication connects to an unauthorized IEEE 802.1x port, the switch requests the client's identity. In this situation, the client does not respond to the request, the port remains in the unauthorized state, and the client is not granted access to the network.

In contrast, when an IEEE 802.1x-enabled client connects to a port that is not running the IEEE 802.1x standard, the client initiates the authentication process by sending the EAPOL-start frame. When no response is received, the client sends the request for a fixed number of times. Because no response is received, the client begins sending frames as if the port is in the authorized state.

You control the port authorization state by using the **dot1x port-control** interface configuration command and these keywords:

- **force-authorized**—disables IEEE 802.1x authentication and causes the port to change to the authorized state without any authentication exchange required. The port sends and receives normal traffic without IEEE 802.1x-based authentication of the client. This is the default setting.
- **force-unauthorized**—causes the port to remain in the unauthorized state, ignoring all attempts by the client to authenticate. The switch cannot provide authentication services to the client through the port.
- **auto**—enables IEEE 802.1x authentication and causes the port to begin in the unauthorized state, allowing only EAPOL frames to be sent and received through the port. The authentication process begins when the link state of the port changes from down to up or when an EAPOL-start frame is received. The switch requests the identity of the client and begins relaying authentication messages between the client and the authentication server. Each client attempting to access the network is uniquely identified by the switch by using the client MAC address.

If the client is successfully authenticated (receives an Accept frame from the authentication server), the port state changes to authorized, and all frames from the authenticated client are allowed through the port. If the authentication fails, the port remains in the unauthorized state, but authentication can be retried. If the authentication server cannot be reached, the switch can resend the request. If no response is received from the server after the specified number of attempts, authentication fails, and network access is not granted.

When a client logs off, it sends an EAPOL-logoff message, causing the switch port to change to the unauthorized state.

If the link state of a port changes from up to down, or if an EAPOL-logoff frame is received, the port returns to the unauthorized state.

IEEE 802.1x Host Mode

You can configure an IEEE 802.1x port for single-host or for multiple-hosts mode. In single-host mode (see [Figure 9-1 on page 9-2](#)), only one client can be connected to the IEEE 802.1x-enabled switch port. The switch detects the client by sending an EAPOL frame when the port link state changes to the up state. If a client leaves or is replaced with another client, the switch changes the port link state to down, and the port returns to the unauthorized state.

In multiple-hosts mode, you can attach multiple hosts to a single IEEE 802.1x-enabled port. [Figure 9-5 on page 9-8](#) shows IEEE 802.1x port-based authentication in a wireless LAN. In this mode, only one of the attached clients must be authorized for all clients to be granted network access. If the port becomes unauthorized (re-authentication fails or an EAPOL-logoff message is received), the switch denies network access to all of the attached clients. In this topology, the wireless access point is responsible for authenticating the clients attached to it, and it also acts as a client to the switch.

With the multiple-hosts mode enabled, you can use IEEE 802.1x authentication to authenticate the port and port security to manage network access for all MAC addresses, including that of the client.

Figure 9-5 Multiple Host Mode Example

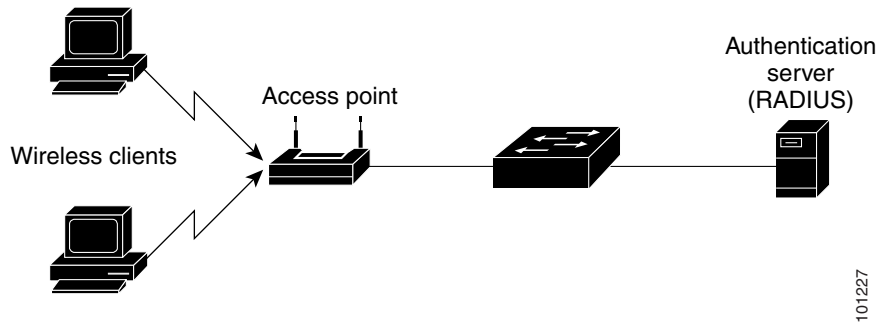

IEEE 802.1x Accounting

The IEEE 802.1x standard defines how users are authorized and authenticated for network access but does not keep track of network usage. IEEE 802.1x accounting is disabled by default. You can enable IEEE 802.1x accounting to monitor this activity on IEEE 802.1x-enabled ports:

- User successfully authenticates.
- User logs off.
- Link-down occurs.
- Re-authentication successfully occurs.
- Re-authentication fails.

The switch does not log IEEE 802.1x accounting information. Instead, it sends this information to the RADIUS server, which must be configured to log accounting messages.

IEEE 802.1x Accounting Attribute-Value Pairs

The information sent to the RADIUS server is represented in the form of Attribute-Value (AV) pairs. These AV pairs provide data for different applications. (For example, a billing application might require information that is in the Acct-Input-Octets or the Acct-Output-Octets attributes of a RADIUS packet.)

AV pairs are automatically sent by a switch that is configured for IEEE 802.1x accounting. Three types of RADIUS accounting packets are sent by a switch:

- START—sent when a new user session starts
- INTERIM—sent during an existing session for updates
- STOP—sent when a session terminates

Table 9-1 lists the AV pairs and when they are sent are sent by the switch:

Table 9-1 Accounting AV Pairs

Attribute Number	AV Pair Name	START	INTERIM	STOP
Attribute[1]	User-Name	Always	Always	Always
Attribute[4]	NAS-IP-Address	Always	Always	Always
Attribute[5]	NAS-Port	Always	Always	Always
Attribute[8]	Framed-IP-Address	Never	Sometimes ¹	Sometimes ¹
Attribute[25]	Class	Always	Always	Always
Attribute[30]	Called-Station-ID	Always	Always	Always
Attribute[31]	Calling-Station-ID	Always	Always	Always
Attribute[40]	Acct-Status-Type	Always	Always	Always
Attribute[41]	Acct-Delay-Time	Always	Always	Always
Attribute[42]	Acct-Input-Octets	Never	Never	Always
Attribute[43]	Acct-Output-Octets	Never	Never	Always
Attribute[44]	Acct-Session-ID	Always	Always	Always
Attribute[45]	Acct-Authentic	Always	Always	Always
Attribute[46]	Acct-Session-Time	Never	Never	Always
Attribute[49]	Acct-Terminate-Cause	Never	Never	Always
Attribute[61]	NAS-Port-Type	Always	Always	Always

1. The Framed-IP-Address AV pair is sent only if a valid Dynamic Host Control Protocol (DHCP) binding exists for the host in the DHCP snooping bindings table.

You can view the AV pairs that are being sent by the switch by entering the **debug radius accounting** privileged EXEC command. For more information about this command, see the *Cisco IOS Debug Command Reference, Release 12.2* at this URL:

http://www.cisco.com/en/US/products/sw/iosswrel/ps1835/products_command_reference_book09186a00800872ce.html

For more information about AV pairs, see RFC 3580, “IEEE 802.1X Remote Authentication Dial In User Service (RADIUS) Usage Guidelines.”

Using IEEE 802.1x Authentication with VLAN Assignment

The RADIUS server sends the VLAN assignment to configure the switch port. The RADIUS server database maintains the username-to-VLAN mappings, assigning the VLAN based on the username of the client connected to the switch port. You can use this feature to limit network access for certain users.

When configured on the switch and the RADIUS server, IEEE 802.1x authentication with VLAN assignment has these characteristics:

- If no VLAN is supplied by the RADIUS server or if IEEE 802.1x authentication is disabled, the port is configured in its access VLAN after successful authentication. Recall that an access VLAN is a VLAN assigned to an access port. All packets sent from or received on this port belong to this VLAN.
- If IEEE 802.1x authentication is enabled but the VLAN information from the RADIUS server is not valid, authorization fails and configured VLAN remains in use. This prevents ports from appearing unexpectedly in an inappropriate VLAN because of a configuration error.

Configuration errors could include specifying a VLAN for a routed port, a malformed VLAN ID, a nonexistent or internal (routed port) VLAN ID, an RSPAN VLAN, a shut down or suspended VLAN. In the case of a multidomain host port, configuration errors can also be due to an attempted assignment of a data VLAN that matches the configured or assigned voice VLAN ID (or the reverse).

- If IEEE 802.1x authentication is enabled and all information from the RADIUS server is valid, the authorized device is placed in the specified VLAN after authentication.
- If the multiple-hosts mode is enabled on an IEEE 802.1x port, all hosts are placed in the same VLAN (specified by the RADIUS server) as the first authenticated host.
- Enabling port security does not impact the RADIUS server-assigned VLAN behavior.
- If IEEE 802.1x authentication is disabled on the port, it is returned to the configured access VLAN and configured voice VLAN.
- If an IEEE 802.1x port is authenticated and put in the RADIUS server-assigned VLAN, any change to the port access VLAN configuration does not take effect. In the case of a multidomain host, the same applies to voice devices when the port is fully authorized with these exceptions:
 - If the VLAN configuration change of one device results in matching the other device configured or assigned VLAN, then authorization of all devices on the port is terminated and multidomain host mode is disabled until a valid configuration is restored where data and voice device configured VLANs no longer match.
 - If a voice device is authorized and is using a downloaded voice VLAN, the removal of the voice VLAN configuration, or modifying the configuration value to *dot1p* or *untagged* results in voice device un-authorization and the disablement of multi-domain host mode.

When the port is in the force authorized, force unauthorized, unauthorized, or shutdown state, it is put into the configured access VLAN.

The IEEE 802.1x authentication with VLAN assignment feature is not supported on trunk ports, dynamic ports, or with dynamic-access port assignment through a VLAN Membership Policy Server (VMPS).

To configure VLAN assignment you need to perform these tasks:

- Enable AAA authorization by using the **network** keyword to allow interface configuration from the RADIUS server.
- Enable IEEE 802.1x authentication. (The VLAN assignment feature is automatically enabled when you configure IEEE 802.1x authentication on an access port).

- Assign vendor-specific tunnel attributes in the RADIUS server. The RADIUS server must return these attributes to the switch:
 - [64] Tunnel-Type = VLAN
 - [65] Tunnel-Medium-Type = 802
 - [81] Tunnel-Private-Group-ID = VLAN name or VLAN ID

Attribute [64] must contain the value *VLAN* (type 13). Attribute [65] must contain the value *802* (type 6). Attribute [81] specifies the *VLAN name* or *VLAN ID* assigned to the IEEE 802.1x-authenticated user.

For examples of tunnel attributes, see the “[Configuring the Switch to Use Vendor-Specific RADIUS Attributes](#)” section on page 8-29.

Using IEEE 802.1x Authentication with Guest VLAN

You can configure a guest VLAN for each IEEE 802.1x port on the switch to provide limited services to clients, such as downloading the IEEE 802.1x client. These clients might be upgrading their system for IEEE 802.1x authentication, and some hosts, such as Windows 98 systems, might not be IEEE 802.1x-capable.

When you enable a guest VLAN on an IEEE 802.1x port, the switch assigns clients to a guest VLAN when the switch does not receive a response to its EAP request/identity frame or when EAPOL packets are not sent by the client.

The switch maintains the EAPOL packet history. If an EAPOL packet is detected on the interface during the lifetime of the link, the switch determines that the device connected to that interface is an IEEE 802.1x-capable supplicant, and the interface does not change to the guest VLAN state. EAPOL history is cleared if the interface link status goes down. If no EAPOL packet is detected on the interface, the interface changes to the guest VLAN state.

In Cisco IOS Release 12.2(25)SEE and later, if devices send EAPOL packets to the switch during the lifetime of the link, the switch no longer allows clients that fail authentication access to the guest VLAN.



Note

If an EAPOL packet is detected after the interface has changed to the guest VLAN, the interface reverts to an unauthorized state, and IEEE 802.1x authentication restarts.

Any number of IEEE 802.1x-incapable clients are allowed access when the switch port is moved to the guest VLAN. If an IEEE 802.1x-capable client joins the same port on which the guest VLAN is configured, the port is put into the unauthorized state in the user-configured access VLAN, and authentication is restarted.

Guest VLANs are supported on IEEE 802.1x ports in single-host or multiple-hosts mode.

You can configure any active VLAN except an RSPAN VLAN or a voice VLAN as an IEEE 802.1x guest VLAN. The guest VLAN feature is not supported on trunk ports; it is supported only on access ports.

The switch supports *MAC authentication bypass* in Cisco IOS Release 12.2(25)SEE and later. When MAC authentication bypass is enabled on an IEEE 802.1x port, the switch can authorize clients based on the client MAC address when IEEE 802.1x authentication times out while waiting for an EAPOL message exchange. After detecting a client on an IEEE 802.1x port, the switch waits for an Ethernet packet from the client. The switch sends the authentication server a RADIUS-access/request frame with a username and password based on the MAC address. If authorization succeeds, the switch grants the

client access to the network. If authorization fails, the switch assigns the port to the guest VLAN if one is specified. For more information, see the [“Using IEEE 802.1x Authentication with MAC Authentication Bypass”](#) section on page 9-16.

For more information, see the [“Configuring a Guest VLAN”](#) section on page 9-30.

Using IEEE 802.1x Authentication with Restricted VLAN

You can configure a restricted VLAN (also referred to as an *authentication failed VLAN*) for each IEEE 802.1x port on a switch to provide limited services to clients that cannot access the guest VLAN. These clients are IEEE 802.1x-compliant and cannot access another VLAN because they fail the authentication process. A restricted VLAN allows users without valid credentials in an authentication server (typically, visitors to an enterprise) to access a limited set of services. The administrator can control the services available to the restricted VLAN.



Note

You can configure a VLAN to be both the guest VLAN and the restricted VLAN if you want to provide the same services to both types of users.

Without this feature, the client attempts and fails authentication indefinitely, and the switch port remains in the spanning-tree blocking state. With this feature, you can configure the switch port to be in the restricted VLAN after a specified number of authentication attempts (the default value is 3 attempts).

The authenticator counts the failed authentication attempts for the client. When this count exceeds the configured maximum number of authentication attempts, the port moves to the restricted VLAN. The failed attempt count increments when the RADIUS server replies with either an *EAP failure* or an empty response without an EAP packet. When the port moves into the restricted VLAN, the failed attempt counter resets.

Users who fail authentication remain in the restricted VLAN until the next re-authentication attempt. A port in the restricted VLAN tries to re-authenticate at configured intervals (the default is 60 seconds). If re-authentication fails, the port remains in the restricted VLAN. If re-authentication is successful, the port moves either to the configured VLAN or to a VLAN sent by the RADIUS server. You can disable re-authentication. If you do this, the only way to restart the authentication process is for the port to receive a *link down* or *EAP logoff* event. We recommend that you keep re-authentication enabled if a client might connect through a hub. When a client disconnects from the hub, the port might not receive the *link down* or *EAP logoff* event.

After a port moves to the restricted VLAN, a simulated EAP success message is sent to the client. This prevents clients from indefinitely attempting authentication. Some clients (for example, devices running Windows XP) cannot implement DHCP without EAP success.

Restricted VLANs are supported only on IEEE 802.1x ports in single-host mode and on Layer 2 ports.

You can configure any active VLAN except an RSPAN VLAN or a voice VLAN as an IEEE 802.1x restricted VLAN. The restricted VLAN feature is not supported on trunk ports; it is supported only on access ports.

This feature works with port security. As soon as the port is authorized, a MAC address is provided to port security. If port security does not permit the MAC address or if the maximum secure address count is reached, the port becomes unauthorized and error disabled.

Other port security features such as dynamic ARP Inspection, DHCP snooping, and IP source guard can be configured independently on a restricted VLAN.

For more information, see the [“Configuring a Restricted VLAN”](#) section on page 9-31.

Using IEEE 802.1x Authentication with Inaccessible Authentication Bypass

In Cisco IOS Release 12.2(25)SEE and later, when the switch cannot reach the configured RADIUS servers and hosts cannot be authenticated, you can configure the switch to allow network access to the hosts connected to *critical* ports. A critical port is enabled for the inaccessible authentication bypass feature, also referred to as *critical authentication* or the *AAA fail policy*.

When this feature is enabled, the switch checks the status of the configured RADIUS servers whenever the switch tries to authenticate a host connected to a critical port. If a server is available, the switch can authenticate the host. However, if all the RADIUS servers are unavailable, the switch grants network access to the host and puts the port in the critical-authentication state, which is a special case of the authentication state.

The behavior of the inaccessible authentication bypass feature depends on the authorization state of the port:

- If the port is unauthorized when a host connected to a critical port tries to authenticate and all servers are unavailable, the switch puts the port in the critical-authentication state in the RADIUS-configured or user-specified access VLAN.
- If the port is already authorized and re-authentication occurs, the switch puts the critical port in the critical-authentication state in the current VLAN, which might be the one previously assigned by the RADIUS server.
- If the RADIUS server becomes unavailable during an authentication exchange, the current exchanges times out, and the switch puts the critical port in the critical-authentication state during the next authentication attempt.

When a RADIUS server that can authenticate the host is available, all critical ports in the critical-authentication state are automatically re-authenticated.

Inaccessible authentication bypass interacts with these features:

- Guest VLAN—Inaccessible authentication bypass is compatible with guest VLAN. When a guest VLAN is enabled on IEEE 802.1x port, the features interact as follows:
 - If at least one RADIUS server is available, the switch assigns a client to a guest VLAN when the switch does not receive a response to its EAP request/identity frame or when EAPOL packets are not sent by the client.
 - If all the RADIUS servers are not available and the client is connected to a critical port, the switch authenticates the client and puts the critical port in the critical-authentication state in the RADIUS-configured or user-specified access VLAN.
 - If all the RADIUS servers are not available and the client is not connected to a critical port, the switch might not assign clients to the guest VLAN if one is configured.
 - If all the RADIUS servers are not available and if a client is connected to a critical port and was previously assigned to a guest VLAN, the switch keeps the port in the guest VLAN.

- **Restricted VLAN**—If the port is already authorized in a restricted VLAN and the RADIUS servers are unavailable, the switch puts the critical port in the critical-authentication state in the restricted VLAN.
- **IEEE 802.1x accounting**—Accounting is not affected if the RADIUS servers are unavailable.
- **Private VLAN**—You can configure inaccessible authentication bypass on a private VLAN host port. The access VLAN must be a secondary private VLAN.
- **Voice VLAN**—Inaccessible authentication bypass is compatible with voice VLAN, but the RADIUS-configured or user-specified access VLAN and the voice VLAN must be different.
- **Remote Switched Port Analyzer (RSPAN)**—Do not configure an RSPAN VLAN as the RADIUS-configured or user-specified access VLAN for inaccessible authentication bypass.

Using IEEE 802.1x Authentication with Voice VLAN Ports

A voice VLAN port is a special access port associated with two VLAN identifiers:

- **VVID** to carry voice traffic to and from the IP phone. The VVID is used to configure the IP phone connected to the port.
- **PVID** to carry the data traffic to and from the workstation connected to the switch through the IP phone. The PVID is the native VLAN of the port.

The IP phone uses the VVID for its voice traffic, regardless of the authorization state of the port. This allows the phone to work independently of IEEE 802.1x authentication.

In single-host mode, only the IP phone is allowed on the voice VLAN. In multiple-hosts mode, additional clients can send traffic on the voice VLAN after a supplicant is authenticated on the PVID. When multiple-hosts mode is enabled, the supplicant authentication affects both the PVID and the VVID.

A voice VLAN port becomes active when there is a link, and the device MAC address appears after the first CDP message from the IP phone. Cisco IP phones do not relay CDP messages from other devices. As a result, if several IP phones are connected in series, the switch recognizes only the one directly connected to it. When IEEE 802.1x authentication is enabled on a voice VLAN port, the switch drops packets from unrecognized IP phones more than one hop away.

When IEEE 802.1x authentication is enabled on a port, you cannot configure a port VLAN that is equal to a voice VLAN.



Note

If you enable IEEE 802.1x authentication on an access port on which a voice VLAN is configured and to which a Cisco IP Phone is connected, the Cisco IP phone loses connectivity to the switch for up to 30 seconds.

For more information about voice VLANs, see [Chapter 14, “Configuring Voice VLAN.”](#)

Using IEEE 802.1x Authentication with Port Security

You can configure an IEEE 802.1x port with port security in either single-host or multiple-hosts mode. (You also must configure port security on the port by using the **switchport port-security** interface configuration command.) When you enable port security and IEEE 802.1x authentication on a port,

IEEE 802.1x authentication authenticates the port, and port security manages network access for all MAC addresses, including that of the client. You can then limit the number or group of clients that can access the network through an IEEE 802.1x port.

These are some examples of the interaction between IEEE 802.1x authentication and port security on the switch:

- When a client is authenticated, and the port security table is not full, the client MAC address is added to the port security list of secure hosts. The port then proceeds to come up normally.

When a client is authenticated and manually configured for port security, it is guaranteed an entry in the secure host table (unless port security static aging has been enabled).

A security violation occurs if the client is authenticated, but the port security table is full. This can happen if the maximum number of secure hosts has been statically configured or if the client ages out of the secure host table. If the client address is aged, its place in the secure host table can be taken by another host.

If the security violation is caused by the first authenticated host, the port becomes error-disabled and immediately shuts down.

The port security violation modes determine the action for security violations. For more information, see the [“Security Violations” section on page 19-9](#).

- When you manually remove an IEEE 802.1x client address from the port security table by using the **no switchport port-security mac-address mac-address** interface configuration command, you should re-authenticate the IEEE 802.1x client by using the **dot1x re-authenticate interface interface-id** privileged EXEC command.
- When an IEEE 802.1x client logs off, the port changes to an unauthenticated state, and all dynamic entries in the secure host table are cleared, including the entry for the client. Normal authentication then takes place.
- If the port is administratively shut down, the port becomes unauthenticated, and all dynamic entries are removed from the secure host table.
- Port security and a voice VLAN can be configured simultaneously on an IEEE 802.1x port that is in either single-host or multiple-hosts mode. Port security applies to both the voice VLAN identifier (VVID) and the port VLAN identifier (PVID).

For more information about enabling port security on your switch, see the [“Configuring Port Security” section on page 19-8](#).

Using IEEE 802.1x Authentication with Wake-on-LAN

The IEEE 802.1x authentication with wake-on-LAN (WoL) feature allows dormant PCs to be powered when the switch receives a specific Ethernet frame, known as the *magic packet*. You can use this feature in environments where administrators need to connect to systems that have been powered down.

When a host that uses WoL is attached through an IEEE 802.1x port and the host powers off, the IEEE 802.1x port becomes unauthorized. The port can only receive and send EAPOL packets, and WoL magic packets cannot reach the host. When the PC is powered off, it is not authorized, and the switch port is not opened.

When the switch uses IEEE 802.1x authentication with WoL, the switch forwards traffic to unauthorized IEEE 802.1x ports, including magic packets. While the port is unauthorized, the switch continues to block ingress traffic other than EAPOL packets. The host can receive packets but cannot send packets to other devices in the network.

**Note**

If PortFast is not enabled on the port, the port is forced to the bidirectional state.

When you configure a port as unidirectional by using the **dot1x control-direction in** interface configuration command, the port changes to the spanning-tree forwarding state. The port can send packets to the host but cannot receive packets from the host.

When you configure a port as bidirectional by using the **dot1x control-direction both** interface configuration command, the port is access-controlled in both directions. The port does not receive packets from or send packets to the host.

Using IEEE 802.1x Authentication with MAC Authentication Bypass

You can configure the switch to authorize clients based on the client MAC address (see [Figure 9-2 on page 9-4](#)) by using the MAC authentication bypass feature. For example, you can enable this feature on IEEE 802.1x ports connected to devices such as printers.

If IEEE 802.1x authentication times out while waiting for an EAPOL response from the client, the switch tries to authorize the client by using MAC authentication bypass.

When the MAC authentication bypass feature is enabled on an IEEE 802.1x port, the switch uses the MAC address as the client identity. The authentication server has a database of client MAC addresses that are allowed network access. After detecting a client on an IEEE 802.1x port, the switch waits for an Ethernet packet from the client. The switch sends the authentication server a RADIUS-access/request frame with a username and password based on the MAC address. If authorization succeeds, the switch grants the client access to the network. If authorization fails, the switch assigns the port to the guest VLAN if one is configured.

If an EAPOL packet is detected on the interface during the lifetime of the link, the switch determines that the device connected to that interface is an IEEE 802.1x-capable supplicant and uses IEEE 802.1x authentication (not MAC authentication bypass) to authorize the interface. EAPOL history is cleared if the interface link status goes down.

If the switch already authorized a port by using MAC authentication bypass and detects an IEEE 802.1x supplicant, the switch does not unauthorize the client connected to the port. When re-authentication occurs, the switch uses IEEE 802.1x authentication as the preferred re-authentication process if the previous session ended because the Termination-Action RADIUS attribute value is *DEFAULT*.

Clients that were authorized with MAC authentication bypass can be re-authenticated. The re-authentication process is the same as that for clients that were authenticated with IEEE 802.1x. During re-authentication, the port remains in the previously assigned VLAN. If re-authentication is successful, the switch keeps the port in the same VLAN. If re-authentication fails, the switch assigns the port to the guest VLAN, if one is configured.

If re-authentication is based on the Session-Timeout RADIUS attribute (Attribute[27]) and the Termination-Action RADIUS attribute (Attribute [29]) and if the Termination-Action RADIUS attribute (Attribute [29]) action is *Initialize*, (the attribute value is *DEFAULT*), the MAC authentication bypass session ends, and connectivity is lost during re-authentication. If MAC authentication bypass is enabled and the IEEE 802.1x authentication times out, the switch uses the MAC authentication bypass feature to initiate re-authorization. For more information about these AV pairs, see RFC 3580, “IEEE 802.1X Remote Authentication Dial In User Service (RADIUS) Usage Guidelines.”

MAC authentication bypass interacts with the features:

- IEEE 802.1x authentication—You can enable MAC authentication bypass only if IEEE 802.1x authentication is enabled on the port.
- Guest VLAN—If a client has an invalid MAC address identity, the switch assigns the client to a guest VLAN if one is configured.
- Restricted VLAN—This feature is not supported when the client connected to an IEEE 802.1x port is authenticated with MAC authentication bypass.
- Port security—See the [“Using IEEE 802.1x Authentication with Port Security”](#) section on page 9-14.
- Voice VLAN—See the [“Using IEEE 802.1x Authentication with Voice VLAN Ports”](#) section on page 9-14.
- VLAN Membership Policy Server (VMPS)—IEEE802.1x and VMPS are mutually exclusive.
- Private VLAN—You can assign a client to a private VLAN.

Using Network Admission Control Layer 2 IEEE 802.1x Validation

In Cisco IOS Release 12.2(25)SED and later, the switch supports the Network Admission Control (NAC) Layer 2 IEEE 802.1x validation, which checks the antivirus condition or *posture* of endpoint systems or clients before granting the devices network access. With NAC Layer 2 IEEE 802.1x validation, you can do these tasks:

- Download the Session-Timeout RADIUS attribute (Attribute[27]) and the Termination-Action RADIUS attribute (Attribute[29]) from the authentication server.
- Set the number of seconds between re-authentication attempts as the value of the Session-Timeout RADIUS attribute (Attribute[27]) and get an access policy against the client from the RADIUS server.
- Set the action to be taken when the switch tries to re-authenticate the client by using the Termination-Action RADIUS attribute (Attribute[29]). If the value is the *DEFAULT* or is not set, the session ends. If the value is RADIUS-Request, the re-authentication process starts.
- View the NAC posture token, which shows the posture of the client, by using the **show dot1x** privileged EXEC command.
- Configure secondary private VLANs as guest VLANs.

Configuring NAC Layer 2 IEEE 802.1x validation is similar to configuring IEEE 802.1x port-based authentication except that you must configure a posture token on the RADIUS server. For information about configuring NAC Layer 2 IEEE 802.1x validation, see the [“Configuring NAC Layer 2 IEEE 802.1x Validation”](#) section on page 9-37 and the [“Configuring Periodic Re-Authentication”](#) section on page 9-25.

For more information about NAC, see the *Network Admission Control Software Configuration Guide*.

Using Web Authentication

You can use a web browser to authenticate a client that does not support IEEE 802.1x functionality. This feature can authenticate up to eight users on the same shared port and apply the appropriate policies for each end host on a shared port.

You can configure a port to use only web authentication. You can also configure the port to first try and use IEEE 802.1x authentication and then to use web authorization if the client does not support IEEE 802.1x authentication.

Web authentication requires two Cisco Attribute-Value (AV) pair attributes:

- The first attribute, `priv-lvl=15`, must always be set to `15`. This sets the privilege level of the user who is logging into the switch.
- The second attribute is an access list to be applied for web authenticated hosts. The syntax is similar to IEEE 802.1X per-user ACLs. However, instead of `ip:inacl`, this attribute must begin with `proxyacl`, and the `source` field in each entry must be `any`. (After authentication, the client IP address replaces the `any` field when the ACL is applied.)

For example:

```
proxyacl# 10=permit ip any 10.0.0.0 255.0.0.0
proxyacl# 20=permit ip any 11.1.0.0 255.255.0.0
proxyacl# 30=permit udp any any eq syslog
proxyacl# 40=permit udp any any eq tftp
```



Note The `proxyacl` entry determines the type of allowed network access.

For more information, see the “[Configuring Web Authentication](#)” section on page 9-38.

Web Authentication with Automatic MAC Check

You can use web authentication with automatic MAC check to authenticate a client that does not support IEEE 802.1x or web browser functionality. This allows end hosts, such as printers, to automatically authenticate by using the MAC address without any additional required configuration.

Web authentication with automatic MAC check only works in web authentication standalone mode. You cannot use this if web authentication is configured as a fallback to IEEE 802.1x authentication.

The MAC address of the device must be configured in the Access Control Server (ACS) for the automatic MAC check to succeed. The automatic MAC check allows managed devices, such as printers, to skip web authentication.



Note

The interoperability of web authentication (with automatic MAC check) and IEEE 802.1x MAC authentication configured on different ports of the same switch is not supported.

Configuring IEEE 802.1x Authentication

These sections contain this configuration information:

- [Default IEEE 802.1x Authentication Configuration](#), page 9-19
- [IEEE 802.1x Authentication Configuration Guidelines](#), page 9-20
- [Configuring IEEE 802.1x Authentication](#), page 9-22 (required)
- [Configuring the Switch-to-RADIUS-Server Communication](#), page 9-24 (required)
- [Configuring the Host Mode](#), page 9-25 (optional)
- [Configuring Periodic Re-Authentication](#), page 9-25 (optional)
- [Manually Re-Authenticating a Client Connected to a Port](#), page 9-26 (optional)

- [Changing the Quiet Period, page 9-26](#) (optional)
- [Changing the Switch-to-Client Retransmission Time, page 9-27](#) (optional)
- [Setting the Switch-to-Client Frame-Retransmission Number, page 9-28](#) (optional)
- [Setting the Re-Authentication Number, page 9-28](#) (optional)
- [Configuring IEEE 802.1x Accounting, page 9-29](#) (optional)
- [Configuring a Guest VLAN, page 9-30](#) (optional)
- [Configuring a Restricted VLAN, page 9-31](#) (optional)
- [Configuring the Inaccessible Authentication Bypass Feature, page 9-33](#) (optional)
- [Configuring IEEE 802.1x Authentication with WoL, page 9-35](#) (optional)
- [Configuring MAC Authentication Bypass, page 9-36](#) (optional)
- [Configuring NAC Layer 2 IEEE 802.1x Validation, page 9-37](#) (optional)
- [Configuring Web Authentication, page 9-38](#) (optional)
- [Disabling IEEE 802.1x Authentication on the Port, page 9-40](#) (optional)
- [Resetting the IEEE 802.1x Authentication Configuration to the Default Values, page 9-41](#) (optional)

Default IEEE 802.1x Authentication Configuration

Table 9-2 shows the default IEEE 802.1x authentication configuration.

Table 9-2 Default IEEE 802.1x Authentication Configuration

Feature	Default Setting
Switch IEEE 802.1x enable state	Disabled.
Per-port IEEE 802.1x enable state	Disabled (force-authorized). The port sends and receives normal traffic without IEEE 802.1x-based authentication of the client.
AAA	Disabled.
RADIUS server <ul style="list-style-type: none"> • IP address • UDP authentication port • Key 	<ul style="list-style-type: none"> • None specified. • 1812. • None specified.
Host mode	Single-host mode.
Control direction	Bidirectional control.
Periodic re-authentication	Disabled.
Number of seconds between re-authentication attempts	3600 seconds.
Re-authentication number	2 times (number of times that the switch restarts the authentication process before the port changes to the unauthorized state).
Quiet period	60 seconds (number of seconds that the switch remains in the quiet state following a failed authentication exchange with the client).

Table 9-2 *Default IEEE 802.1x Authentication Configuration (continued)*

Feature	Default Setting
Retransmission time	30 seconds (number of seconds that the switch should wait for a response to an EAP request/identity frame from the client before resending the request).
Maximum retransmission number	2 times (number of times that the switch will send an EAP-request/identity frame before restarting the authentication process).
Client timeout period	30 seconds (when relaying a request from the authentication server to the client, the amount of time the switch waits for a response before resending the request to the client.)
Authentication server timeout period	30 seconds (when relaying a response from the client to the authentication server, the amount of time the switch waits for a reply before resending the response to the server. This setting is not configurable.)
Guest VLAN	None specified.
Inaccessible authentication bypass	Disabled.
Restricted VLAN	None specified.
Authenticator (switch) mode	None specified.
MAC authentication bypass	Disabled.

IEEE 802.1x Authentication Configuration Guidelines

This section has configuration guidelines for these features:

- [IEEE 802.1x Authentication, page 9-20](#)
- [VLAN Assignment, Guest VLAN, Restricted VLAN, and Inaccessible Authentication Bypass, page 9-21](#)
- [MAC Authentication Bypass, page 9-22](#)

IEEE 802.1x Authentication

These are the IEEE 802.1x authentication configuration guidelines:

- When IEEE 802.1x authentication is enabled, ports are authenticated before any other Layer 2 feature is enabled.
- If you try to change the mode of an IEEE 802.1x-enabled port (for example, from access to trunk), an error message appears, and the port mode is not changed.
- If the VLAN to which an IEEE 802.1x-enabled port is assigned changes, this change is transparent and does not affect the switch. For example, this change occurs if a port is assigned to a RADIUS server-assigned VLAN and is then assigned to a different VLAN after re-authentication.

If the VLAN to which an IEEE 802.1x port is assigned to shut down, disabled, or removed, the port becomes unauthorized. For example, the port is unauthorized after the access VLAN to which a port is assigned shuts down or is removed.

- The IEEE 802.1x protocol is supported on Layer 2 static-access ports and voice VLAN ports, but it is not supported on these port types:
 - Trunk port—If you try to enable IEEE 802.1x authentication on a trunk port, an error message appears, and IEEE 802.1x authentication is not enabled. If you try to change the mode of an IEEE 802.1x-enabled port to trunk, an error message appears, and the port mode is not changed.
 - Dynamic ports—A port in dynamic mode can negotiate with its neighbor to become a trunk port. If you try to enable IEEE 802.1x authentication on a dynamic port, an error message appears, and IEEE 802.1x authentication is not enabled. If you try to change the mode of an IEEE 802.1x-enabled port to dynamic, an error message appears, and the port mode is not changed.
 - Dynamic-access ports—If you try to enable IEEE 802.1x authentication on a dynamic-access (VLAN Query Protocol [VQP]) port, an error message appears, and IEEE 802.1x authentication is not enabled. If you try to change an IEEE 802.1x-enabled port to dynamic VLAN assignment, an error message appears, and the VLAN configuration is not changed.
 - EtherChannel port—Do not configure a port that is an active or a not-yet-active member of an EtherChannel as an IEEE 802.1x port. If you try to enable IEEE 802.1x authentication on an EtherChannel port, an error message appears, and IEEE 802.1x authentication is not enabled.
 - Switched Port Analyzer (SPAN) and Remote SPAN (RSPAN) destination ports—You can enable IEEE 802.1x authentication on a port that is a SPAN or RSPAN destination port. However, IEEE 802.1x authentication is disabled until the port is removed as a SPAN or RSPAN destination port. You can enable IEEE 802.1x authentication on a SPAN or RSPAN source port.
- Before globally enabling IEEE 802.1x authentication on a switch by entering the **dot1x system-auth-control** global configuration command, remove the EtherChannel configuration from the interfaces on which IEEE 802.1x authentication and EtherChannel are configured.

VLAN Assignment, Guest VLAN, Restricted VLAN, and Inaccessible Authentication Bypass

These are the configuration guidelines for VLAN assignment, guest VLAN, restricted VLAN, and inaccessible authentication bypass:

- When IEEE 802.1x authentication is enabled on a port, you cannot configure a port VLAN that is equal to a voice VLAN.
- The IEEE 802.1x authentication with VLAN assignment feature is not supported on trunk ports, dynamic ports, or with dynamic-access port assignment through a VMPS.
- You can configure any VLAN except an RSPAN VLAN or a voice VLAN as an IEEE 802.1x guest VLAN. The guest VLAN feature is not supported on trunk ports; it is supported only on access ports.
- After you configure a guest VLAN for an IEEE 802.1x port to which a DHCP client is connected, you might need to get a host IP address from a DHCP server. You can change the settings for restarting the IEEE 802.1x authentication process on the switch before the DHCP process on the client times out and tries to get a host IP address from the DHCP server. Decrease the settings for the IEEE 802.1x authentication process (**dot1x timeout quiet-period** and **dot1x timeout tx-period** interface configuration commands). The amount to decrease the settings depends on the connected IEEE 802.1x client type.
- When configuring the inaccessible authentication bypass feature, follow these guidelines:
 - The feature is supported on IEEE 802.1x port in single-host mode and multihosts mode.
 - If the client is running Windows XP and the port to which the client is connected is in the critical-authentication state, Windows XP might report that the interface is not authenticated.

- If the Windows XP client is configured for DHCP and has an IP address from the DHCP server, receiving an EAP-Success message on a critical port might not re-initiate the DHCP configuration process.
- You can configure the inaccessible authentication bypass feature and the restricted VLAN on an IEEE 802.1x port. If the switch tries to re-authenticate a critical port in a restricted VLAN and all the RADIUS servers are unavailable, switch changes the port state to the critical authentication state and remains in the restricted VLAN.
- You can configure the inaccessible bypass feature and port security on the same switch port.
- You can configure any VLAN except an RSPAN VLAN or a voice VLAN as an IEEE 802.1x restricted VLAN. The restricted VLAN feature is not supported on trunk ports; it is supported only on access ports.

MAC Authentication Bypass

These are the MAC authentication bypass configuration guidelines:

- Unless otherwise stated, the MAC authentication bypass guidelines are the same as the IEEE 802.1x authentication guidelines. For more information, see the [“IEEE 802.1x Authentication” section on page 9-20](#).
- If you disable MAC authentication bypass from a port after the port has been authorized with its MAC address, the port state is not affected.
- If the port is in the unauthorized state and the client MAC address is not the authentication-server database, the port remains in the unauthorized state. However, if the client MAC address is added to the database, the switch can use MAC authentication bypass to re-authorize the port.
- If the port is in the authorized state, the port remains in this state until re-authorization occurs.

Upgrading from a Previous Software Release

In Cisco IOS Release 12.2(25)SEE, the implementation for IEEE 802.1x authentication changed from the previous releases. When IEEE 802.1x authentication is enabled, information about Port Fast is no longer added to the configuration and this information appears in the running configuration:

```
dot1x pae authenticator
```

Configuring IEEE 802.1x Authentication

To configure IEEE 802.1x port-based authentication, you must enable authentication, authorization, and accounting (AAA) and specify the authentication method list. A method list describes the sequence and authentication method to be queried to authenticate a user.

To allow VLAN assignment, you must enable AAA authorization to configure the switch for all network-related service requests.

This is the IEEE 802.1x AAA process:

-
- Step 1** A user connects to a port on the switch.
 - Step 2** Authentication is performed.
 - Step 3** VLAN assignment is enabled, as appropriate, based on the RADIUS server configuration.

- Step 4** The switch sends a start message to an accounting server.
- Step 5** Re-authentication is performed, as necessary.
- Step 6** The switch sends an interim accounting update to the accounting server that is based on the result of re-authentication.
- Step 7** The user disconnects from the port.
- Step 8** The switch sends a stop message to the accounting server.

Beginning in privileged EXEC mode, follow these steps to configure IEEE 802.1x port-based authentication:

	Command	Purpose
Step 1	configure terminal	Enter global configuration mode.
Step 2	aaa new-model	Enable AAA.
Step 3	aaa authentication dot1x {default} method1	Create an IEEE 802.1x authentication method list. To create a default list that is used when a named list is <i>not</i> specified in the authentication command, use the default keyword followed by the method that is to be used in default situations. The default method list is automatically applied to all ports. For <i>method1</i> , enter the group radius keywords to use the list of all RADIUS servers for authentication. Note Though other keywords are visible in the command-line help string, only the group radius keywords are supported.
Step 4	dot1x system-auth-control	Enable IEEE 802.1x authentication globally on the switch.
Step 5	aaa authorization network {default} group radius	(Optional) Configure the switch to use user-RADIUS authorization for all network-related service requests, such as VLAN assignment.
Step 6	radius-server host ip-address	(Optional) Specify the IP address of the RADIUS server.
Step 7	radius-server key string	(Optional) Specify the authentication and encryption key used between the switch and the RADIUS daemon running on the RADIUS server.
Step 8	interface interface-id	Specify the port connected to the client that is to be enabled for IEEE 802.1x authentication, and enter interface configuration mode.
Step 9	switchport mode access	(Optional) Set the port to access mode only if you configured the RADIUS server in Step 6 and Step 7.
Step 10	dot1x port-control auto	Enable IEEE 802.1x authentication on the port. For feature interaction information, see the “ IEEE 802.1x Authentication Configuration Guidelines ” section on page 9-20.
Step 11	end	Return to privileged EXEC mode.
Step 12	show dot1x	Verify your entries.
Step 13	copy running-config startup-config	(Optional) Save your entries in the configuration file.

Configuring the Switch-to-RADIUS-Server Communication

RADIUS security servers are identified by their hostname or IP address, hostname and specific UDP port numbers, or IP address and specific UDP port numbers. The combination of the IP address and UDP port number creates a unique identifier, which enables RADIUS requests to be sent to multiple UDP ports on a server at the same IP address. If two different host entries on the same RADIUS server are configured for the same service—for example, authentication—the second host entry configured acts as the fail-over backup to the first one. The RADIUS host entries are tried in the order that they were configured.

Beginning in privileged EXEC mode, follow these steps to configure the RADIUS server parameters on the switch. This procedure is required.

	Command	Purpose
Step 1	configure terminal	Enter global configuration mode.
Step 2	radius-server host { <i>hostname</i> <i>ip-address</i> } auth-port <i>port-number</i> key <i>string</i>	<p>Configure the RADIUS server parameters.</p> <p>For <i>hostname</i> <i>ip-address</i>, specify the hostname or IP address of the remote RADIUS server.</p> <p>For auth-port <i>port-number</i>, specify the UDP destination port for authentication requests. The default is 1812. The range is 0 to 65536.</p> <p>For key <i>string</i>, specify the authentication and encryption key used between the switch and the RADIUS daemon running on the RADIUS server. The key is a text string that must match the encryption key used on the RADIUS server.</p> <p>Note Always configure the key as the last item in the radius-server host command syntax because leading spaces are ignored, but spaces within and at the end of the key are used. If you use spaces in the key, do not enclose the key in quotation marks unless the quotation marks are part of the key. This key must match the encryption used on the RADIUS daemon.</p> <p>If you want to use multiple RADIUS servers, re-enter this command.</p>
Step 3	end	Return to privileged EXEC mode.
Step 4	show running-config	Verify your entries.
Step 5	copy running-config startup-config	(Optional) Save your entries in the configuration file.

To delete the specified RADIUS server, use the **no radius-server host** {*hostname* | *ip-address*} global configuration command.

This example shows how to specify the server with IP address 172.20.39.46 as the RADIUS server, to use port 1612 as the authorization port, and to set the encryption key to *rad123*, matching the key on the RADIUS server:

```
Switch(config)# radius-server host 172.120.39.46 auth-port 1612 key rad123
```

You can globally configure the timeout, retransmission, and encryption key values for all RADIUS servers by using the **radius-server host** global configuration command. If you want to configure these options on a per-server basis, use the **radius-server timeout**, **radius-server retransmit**, and the **radius-server key** global configuration commands. For more information, see the [“Configuring Settings for All RADIUS Servers” section on page 8-29](#).

You also need to configure some settings on the RADIUS server. These settings include the IP address of the switch and the key string to be shared by both the server and the switch. For more information, see the RADIUS server documentation.

Configuring the Host Mode

Beginning in privileged EXEC mode, follow these steps to allow a single host (client) or multiple hosts on an IEEE 802.1x-authorized port that has the dot1x port-control interface configuration command set to **auto**. This procedure is optional.

	Command	Purpose
Step 1	configure terminal	Enter global configuration mode.
Step 2	radius-server vsa send authentication	Configure the network access server to recognize and use vendor-specific attributes (VSAs).
Step 3	interface <i>interface-id</i>	Specify the port to which multiple hosts are indirectly attached, and enter interface configuration mode.
Step 4	dot1x host-mode { single-host multi-host }	The keywords have these meanings: <ul style="list-style-type: none"> • single-host—Allow a single host (client) on an IEEE 802.1x-authorized port. • multi-host—Allow multiple hosts on an IEEE 802.1x-authorized port after a single host has been authenticated. Make sure that the dot1x port-control interface configuration command set is set to auto for the specified interface.
Step 5	switchport voice vlan <i>vlan-id</i>	(Optional) Configure the voice VLAN.
Step 6	end	Return to privileged EXEC mode.
Step 7	show dot1x interface <i>interface-id</i>	Verify your entries.
Step 8	copy running-config startup-config	(Optional) Save your entries in the configuration file.

To disable multiple hosts on the port, use the **no dot1x host-mode multi-host** interface configuration command.

This example shows how to enable IEEE 802.1x authentication and to allow multiple hosts:

```
Switch(config)# interface gigabitethernet/0/1

Switch(config-if)# dot1x port-control auto
Switch(config-if)# dot1x host-mode multi-host
Switch(config-if)# end
```

Configuring Periodic Re-Authentication

You can enable periodic IEEE 802.1x client re-authentication and specify how often it occurs. If you do not specify a time period before enabling re-authentication, the number of seconds between attempts is 3600.

Beginning in privileged EXEC mode, follow these steps to enable periodic re-authentication of the client and to configure the number of seconds between re-authentication attempts. This procedure is optional.

	Command	Purpose
Step 1	<code>configure terminal</code>	Enter global configuration mode.
Step 2	<code>interface interface-id</code>	Specify the port to be configured, and enter interface configuration mode.
Step 3	<code>dot1x reauthentication</code>	Enable periodic re-authentication of the client, which is disabled by default.
Step 4	<code>dot1x timeout reauth-period {seconds server}</code>	<p>Set the number of seconds between re-authentication attempts.</p> <p>The keywords have these meanings:</p> <ul style="list-style-type: none"> <code>seconds</code>—Sets the number of seconds from 1 to 65535; the default is 3600 seconds. <code>server</code>—Sets the number of seconds based on the value of the Session-Timeout RADIUS attribute (Attribute[27]) and the Termination-Action RADIUS attribute (Attribute [29]). <p>This command affects the behavior of the switch only if periodic re-authentication is enabled.</p>
Step 5	<code>end</code>	Return to privileged EXEC mode.
Step 6	<code>show dot1x interface interface-id</code>	Verify your entries.
Step 7	<code>copy running-config startup-config</code>	(Optional) Save your entries in the configuration file.

To disable periodic re-authentication, use the **no dot1x reauthentication** interface configuration command. To return to the default number of seconds between re-authentication attempts, use the **no dot1x timeout reauth-period** interface configuration command.

This example shows how to enable periodic re-authentication and set the number of seconds between re-authentication attempts to 4000:

```
Switch(config-if)# dot1x reauthentication
Switch(config-if)# dot1x timeout reauth-period 4000
```

Manually Re-Authenticating a Client Connected to a Port

You can manually re-authenticate the client connected to a specific port at any time by entering the **dot1x re-authenticate interface interface-id** privileged EXEC command. This step is optional. If you want to enable or disable periodic re-authentication, see the [“Configuring Periodic Re-Authentication” section on page 9-25](#).

This example shows how to manually re-authenticate the client connected to a port:

```
Switch# dot1x re-authenticate interface gigabitethernet0/1
```

Changing the Quiet Period

When the switch cannot authenticate the client, the switch remains idle for a set period of time and then tries again. The **dot1x timeout quiet-period** interface configuration command controls the idle period. A failed authentication of the client might occur because the client provided an invalid password. You can provide a faster response time to the user by entering a number smaller than the default.

Beginning in privileged EXEC mode, follow these steps to change the quiet period. This procedure is optional.

	Command	Purpose
Step 1	configure terminal	Enter global configuration mode.
Step 2	interface <i>interface-id</i>	Specify the port to be configured, and enter interface configuration mode.
Step 3	dot1x timeout quiet-period <i>seconds</i>	Set the number of seconds that the switch remains in the quiet state following a failed authentication exchange with the client. The range is 1 to 65535 seconds; the default is 60.
Step 4	end	Return to privileged EXEC mode.
Step 5	show dot1x interface <i>interface-id</i>	Verify your entries.
Step 6	copy running-config startup-config	(Optional) Save your entries in the configuration file.

To return to the default quiet time, use the **no dot1x timeout quiet-period** interface configuration command.

This example shows how to set the quiet time on the switch to 30 seconds:

```
Switch(config-if)# dot1x timeout quiet-period 30
```

Changing the Switch-to-Client Retransmission Time

The client responds to the EAP-request/identity frame from the switch with an EAP-response/identity frame. If the switch does not receive this response, it waits a set period of time (known as the retransmission time) and then resends the frame.



Note

You should change the default value of this command only to adjust for unusual circumstances such as unreliable links or specific behavioral problems with certain clients and authentication servers.

Beginning in privileged EXEC mode, follow these steps to change the amount of time that the switch waits for client notification. This procedure is optional.

	Command	Purpose
Step 1	configure terminal	Enter global configuration mode.
Step 2	interface <i>interface-id</i>	Specify the port to be configured, and enter interface configuration mode.
Step 3	dot1x timeout tx-period <i>seconds</i>	Set the number of seconds that the switch waits for a response to an EAP-request/identity frame from the client before resending the request. The range is 1 to 65535 seconds; the default is 5.
Step 4	end	Return to privileged EXEC mode.
Step 5	show dot1x interface <i>interface-id</i>	Verify your entries.
Step 6	copy running-config startup-config	(Optional) Save your entries in the configuration file.

To return to the default retransmission time, use the **no dot1x timeout tx-period** interface configuration command.

This example shows how to set 60 as the number of seconds that the switch waits for a response to an EAP-request/identity frame from the client before resending the request:

```
Switch(config-if)# dot1x timeout tx-period 60
```

Setting the Switch-to-Client Frame-Retransmission Number

In addition to changing the switch-to-client retransmission time, you can change the number of times that the switch sends an EAP-request/identity frame (assuming no response is received) to the client before restarting the authentication process.



Note

You should change the default value of this command only to adjust for unusual circumstances such as unreliable links or specific behavioral problems with certain clients and authentication servers.

Beginning in privileged EXEC mode, follow these steps to set the switch-to-client frame-retransmission number. This procedure is optional.

	Command	Purpose
Step 1	configure terminal	Enter global configuration mode.
Step 2	interface <i>interface-id</i>	Specify the port to be configured, and enter interface configuration mode.
Step 3	dot1x max-reauth-req <i>count</i>	Set the number of times that the switch sends an EAP-request/identity frame to the client before restarting the authentication process. The range is 1 to 10; the default is 2.
Step 4	end	Return to privileged EXEC mode.
Step 5	show dot1x interface <i>interface-id</i>	Verify your entries.
Step 6	copy running-config startup-config	(Optional) Save your entries in the configuration file.

To return to the default retransmission number, use the **no dot1x max-req** interface configuration command.

This example shows how to set 5 as the number of times that the switch sends an EAP-request/identity request before restarting the authentication process:

```
Switch(config-if)# dot1x max-req 5
```

Setting the Re-Authentication Number

You can also change the number of times that the switch restarts the authentication process before the port changes to the unauthorized state.



Note

You should change the default value of this command only to adjust for unusual circumstances such as unreliable links or specific behavioral problems with certain clients and authentication servers.

Beginning in privileged EXEC mode, follow these steps to set the re-authentication number. This procedure is optional.

	Command	Purpose
Step 1	configure terminal	Enter global configuration mode.
Step 2	interface <i>interface-id</i>	Specify the port to be configured, and enter interface configuration mode.
Step 3	dot1x max-reauth-req <i>count</i>	Set the number of times that the switch restarts the authentication process before the port changes to the unauthorized state. The range is 0 to 10; the default is 2.
Step 4	end	Return to privileged EXEC mode.
Step 5	show dot1x interface <i>interface-id</i>	Verify your entries.
Step 6	copy running-config startup-config	(Optional) Save your entries in the configuration file.

To return to the default re-authentication number, use the **no dot1x max-reauth-req** interface configuration command.

This example shows how to set 4 as the number of times that the switch restarts the authentication process before the port changes to the unauthorized state:

```
Switch(config-if)# dot1x max-reauth-req 4
```

Configuring IEEE 802.1x Accounting

Enabling AAA system accounting with IEEE 802.1x accounting allows system reload events to be sent to the accounting RADIUS server for logging. The server can then infer that all active IEEE 802.1x sessions are closed.

Because RADIUS uses the unreliable UDP transport protocol, accounting messages might be lost due to poor network conditions. If the switch does not receive the accounting response message from the RADIUS server after a configurable number of retransmissions of an accounting request, this system message appears:

```
Accounting message %s for session %s failed to receive Accounting Response.
```

When the stop message is not sent successfully, this message appears:

```
00:09:55: %RADIUS-4-RADIUS_DEAD: RADIUS server 172.20.246.201:1645,1646 is not responding.
```



Note

You must configure the RADIUS server to perform accounting tasks, such as logging start, stop, and interim-update messages and time stamps. To turn on these functions, enable logging of “Update/Watchdog packets from this AAA client” in your RADIUS server Network Configuration tab. Next, enable “CVS RADIUS Accounting” in your RADIUS server System Configuration tab.

Beginning in privileged EXEC mode, follow these steps to configure IEEE 802.1x accounting after AAA is enabled on your switch. This procedure is optional.

	Command	Purpose
Step 1	configure terminal	Enter global configuration mode.
Step 2	interface <i>interface-id</i>	Specify the port to be configured, and enter interface configuration mode.

	Command	Purpose
Step 3	aaa accounting dot1x default start-stop group radius	Enable IEEE 802.1x accounting using the list of all RADIUS servers.
Step 4	aaa accounting system default start-stop group radius	(Optional) Enables system accounting (using the list of all RADIUS servers) and generates system accounting reload event messages when the switch reloads.
Step 5	end	Return to privileged EXEC mode.
Step 6	show running-config	Verify your entries.
Step 7	copy running-config startup-config	(Optional) Saves your entries in the configuration file.

Use the **show radius statistics** privileged EXEC command to display the number of RADIUS messages that do not receive the accounting response message.

This example shows how to configure IEEE 802.1x accounting. The first command configures the RADIUS server, specifying 1813 as the UDP port for accounting:

```
Switch(config)# radius-server host 172.120.39.46 auth-port 1812 acct-port 1813 key rad123
Switch(config)# aaa accounting dot1x default start-stop group radius
Switch(config)# aaa accounting system default start-stop group radius
```

Configuring a Guest VLAN

When you configure a guest VLAN, clients that are not IEEE 802.1x-capable are put into the guest VLAN when the server does not receive a response to its EAP request/identity frame. Clients that are IEEE 802.1x-capable but that fail authentication are not granted network access. The switch supports guest VLANs in single-host or multiple-hosts mode.

Beginning in privileged EXEC mode, follow these steps to configure a guest VLAN. This procedure is optional.

	Command	Purpose
Step 1	configure terminal	Enter global configuration mode.
Step 2	interface interface-id	Specify the port to be configured, and enter interface configuration mode. For the supported port types, see the “IEEE 802.1x Authentication Configuration Guidelines” section on page 9-20.
Step 3	switchport mode access or switchport mode private-vlan host	Set the port to access mode, or Configure the port as a private-VLAN host port.
Step 4	dot1x port-control auto	Enable IEEE 802.1x authentication on the port.
Step 5	dot1x guest-vlan vlan-id	Specify an active VLAN as an IEEE 802.1x guest VLAN. The range is 1 to 4094. You can configure any active VLAN except an RSPAN VLAN or a voice VLAN as an IEEE 802.1x guest VLAN.
Step 6	end	Return to privileged EXEC mode.
Step 7	show dot1x interface interface-id	Verify your entries.
Step 8	copy running-config startup-config	(Optional) Save your entries in the configuration file.

To disable and remove the guest VLAN, use the **no dot1x guest-vlan** interface configuration command. The port returns to the unauthorized state.

This example shows how to enable VLAN 2 as an IEEE 802.1x guest VLAN:

```
Switch(config)# interface gigabitethernet0/2
Switch(config-if)# dot1x guest-vlan 2
```

This example shows how to set 3 as the quiet time on the switch, to set 15 as the number of seconds that the switch waits for a response to an EAP-request/identity frame from the client before re-sending the request, and to enable VLAN 2 as an IEEE 802.1x guest VLAN when an IEEE 802.1x port is connected to a DHCP client:

```
Switch(config-if)# dot1x timeout quiet-period 3
Switch(config-if)# dot1x timeout tx-period 15
Switch(config-if)# dot1x guest-vlan 2
```

Configuring a Restricted VLAN

When you configure a restricted VLAN on a switch, clients that are IEEE 802.1x-compliant are moved into the restricted VLAN when the authentication server does not receive a valid username and password. The switch supports restricted VLANs only in single-host mode.

Beginning in privileged EXEC mode, follow these steps to configure a restricted VLAN. This procedure is optional.

	Command	Purpose
Step 1	configure terminal	Enter global configuration mode.
Step 2	interface <i>interface-id</i>	Specify the port to be configured, and enter interface configuration mode. For the supported port types, see the “ IEEE 802.1x Authentication Configuration Guidelines ” section on page 9-20.
Step 3	switchport mode access	Set the port to access mode,
	or switchport mode private-vlan host	or Configure the port as a private-VLAN host port.
Step 4	dot1x port-control auto	Enable IEEE 802.1x authentication on the port.
Step 5	dot1x auth-fail vlan <i>vlan-id</i>	Specify an active VLAN as an IEEE 802.1x restricted VLAN. The range is 1 to 4094. You can configure any active VLAN except an RSPAN VLAN or a voice VLAN as an IEEE 802.1x restricted VLAN.
Step 6	end	Return to privileged EXEC mode.
Step 7	show dot1x interface <i>interface-id</i>	(Optional) Verify your entries.
Step 8	copy running-config startup-config	(Optional) Save your entries in the configuration file.

To disable and remove the restricted VLAN, use the **no dot1x auth-fail vlan** interface configuration command. The port returns to the unauthorized state.

This example shows how to enable VLAN 2 as an IEEE 802.1x restricted VLAN:

```
Switch(config)# interface gigabitethernet0/2
Switch(config-if)# dot1x auth-fail vlan 2
```

You can configure the maximum number of authentication attempts allowed before a user is assigned to the restricted VLAN by using the **dot1x auth-fail max-attempts** interface configuration command. The range of allowable authentication attempts is 1 to 3. The default is 3 attempts.

Beginning in privileged EXEC mode, follow these steps to configure the maximum number of allowed authentication attempts. This procedure is optional.

	Command	Purpose
Step 1	configure terminal	Enter global configuration mode.
Step 2	interface <i>interface-id</i>	Specify the port to be configured, and enter interface configuration mode. For the supported port types, see the “ IEEE 802.1x Authentication Configuration Guidelines ” section on page 9-20.
Step 3	switchport mode access	Set the port to access mode,
	or switchport mode private-vlan host	or Configure the port as a private-VLAN host port.
Step 4	dot1x port-control auto	Enable IEEE 802.1x authentication on the port.
Step 5	dot1x auth-fail vlan <i>vlan-id</i>	Specify an active VLAN as an IEEE 802.1x restricted VLAN. The range is 1 to 4094. You can configure any active VLAN except an RSPAN VLAN or a voice VLAN as an IEEE 802.1x restricted VLAN.
Step 6	dot1x auth-fail max-attempts <i>max attempts</i>	Specify a number of authentication attempts to allow before a port moves to the restricted VLAN. The range is 1 to 3, and the default is 3.
Step 7	end	Return to privileged EXEC mode.
Step 8	show dot1x interface <i>interface-id</i>	(Optional) Verify your entries.
Step 9	copy running-config startup-config	(Optional) Save your entries in the configuration file.

To return to the default value, use the **no dot1x auth-fail max-attempts** interface configuration command.

This example shows how to set 2 as the number of authentication attempts allowed before the port moves to the restricted VLAN:

```
Switch(config-if)# dot1x auth-fail max-attempts 2
```

Configuring the Inaccessible Authentication Bypass Feature

You can configure the inaccessible bypass feature, also referred to as critical authentication or the AAA fail policy.

Beginning in privileged EXEC mode, follow these steps to configure the port as a critical port and enable the inaccessible authentication bypass feature. This procedure is optional.

	Command	Purpose
Step 1	configure terminal	Enter global configuration mode.
Step 2	radius-server dead-criteria time <i>time</i> tries <i>tries</i>	(Optional) Set the conditions that are used to decide when a RADIUS server is considered unavailable or <i>dead</i> . The range for <i>time</i> is from 1 to 120 seconds. The switch dynamically determines the default <i>seconds</i> value that is 10 to 60 seconds. The range for <i>tries</i> is from 1 to 100. The switch dynamically determines the default <i>tries</i> parameter that is 10 to 100.
Step 3	radius-server deadtime <i>minutes</i>	(Optional) Set the number of minutes that a RADIUS server is not sent requests. The range is from 0 to 1440 minutes (24 hours). The default is 0 minutes.

Command	Purpose
<p>Step 4 radius-server host <i>ip-address</i> [acct-port <i>udp-port</i>] [auth-port <i>udp-port</i>] [test username <i>name</i> [idle-time <i>time</i>] [ignore-acct-port] [ignore-auth-port]] [key <i>string</i>]</p>	<p>(Optional) Configure the RADIUS server parameters by using these keywords:</p> <ul style="list-style-type: none"> • acct-port <i>udp-port</i>—Specify the UDP port for the RADIUS accounting server. The range for the UDP port number is from 0 to 65536. The default is 1646. • auth-port <i>udp-port</i>—Specify the UDP port for the RADIUS authentication server. The range for the UDP port number is from 0 to 65536. The default is 1645. <p>Note You should configure the UDP port for the RADIUS accounting server and the UDP port for the RADIUS authentication server to nondefault values.</p> <ul style="list-style-type: none"> • test username <i>name</i>—Enable automated testing of the RADIUS server status, and specify the username to be used. • idle-time <i>time</i>—Set the interval of time in minutes after which the switch sends test packets to the server. The range is from 1 to 35791 minutes. The default is 60 minutes (1 hour). • ignore-acct-port—Disable testing on the RADIUS-server accounting port. • ignore-auth-port—Disable testing on the RADIUS-server authentication port. • key <i>string</i>—Specify the authentication and encryption key for all RADIUS communication between the switch and the RADIUS daemon. <p>Note Always configure the key as the last item in the radius-server host command syntax because leading spaces are ignored, but spaces within and at the end of the key are used. If you use spaces in the key, do not enclose the key in quotation marks unless the quotation marks are part of the key. This key must match the encryption used on the RADIUS daemon.</p> <p>You can also configure the authentication and encryption key by using the radius-server key {<i>0 string</i> <i>7 string</i> <i>string</i>} global configuration command.</p>
<p>Step 5 dot1x critical {eapol recovery delay <i>milliseconds</i>}</p>	<p>(Optional) Configure the parameters for inaccessible authentication bypass:</p> <p>eapol—Specify that the switch sends an EAPOL-Success message when the switch successfully authenticates the critical port.</p> <p>recovery delay <i>milliseconds</i>—Set the recovery delay period during which the switch waits to re-initialize a critical port when a RADIUS server that was unavailable becomes available. The range is from 1 to 10000 milliseconds. The default is 1000 milliseconds (a port can be re-initialized every second).</p>
<p>Step 6 interface <i>interface-id</i></p>	<p>Specify the port to be configured, and enter interface configuration mode. For the supported port types, see the “IEEE 802.1x Authentication Configuration Guidelines” section on page 9-20.</p>

	Command	Purpose
Step 7	dot1x critical [recovery action reinitialize vlan <i>vlan-id</i>]	Enable the inaccessible authentication bypass feature, and use these keywords to configure the feature: <ul style="list-style-type: none"> • recovery action reinitialize—Enable the recovery feature, and specify that the recovery action is to authenticate the port when an authentication server is available. • vlan <i>vlan-id</i>—Specify the access VLAN to which the switch can assign a critical port. The range is from 1 to 4094.
Step 8	end	Return to privileged EXEC mode.
Step 9	show dot1x [interface <i>interface-id</i>]	(Optional) Verify your entries.
Step 10	copy running-config startup-config	(Optional) Save your entries in the configuration file.

To return to the RADIUS server default settings, use the **no radius-server dead-criteria**, the **no radius-server deadtime**, and the **no radius-server host** global configuration commands. To return to the default settings of inaccessible authentication bypass, use the **no dot1x critical {eapol | recovery delay}** global configuration command. To disable inaccessible authentication bypass, use the **no dot1x critical** interface configuration command.

This example shows how to configure the inaccessible authentication bypass feature:

```
Switch(config)# radius-server dead-criteria time 30 tries 20
Switch(config)# radius-server deadtime 60
Switch(config)# radius-server host 1.1.1.2 acct-port 1550 auth-port 1560 test username
user1 idle-time 30 key abc1234
Switch(config)# dot1x critical eapol
Switch(config)# dot1x critical recovery delay 2000
Switch(config)# interface gigabitethernet 0/1
Switch(config)# radius-server deadtime 60
Switch(config-if)# dot1x critical
Switch(config-if)# dot1x critical recovery action reinitialize
Switch(config-if)# dot1x critical vlan 20
Switch(config-if)# end
```

Configuring IEEE 802.1x Authentication with WoL

Beginning in privileged EXEC mode, follow these steps to enable IEEE 802.1x authentication with WoL. This procedure is optional.

	Command	Purpose
Step 1	configure terminal	Enter global configuration mode.
Step 2	interface <i>interface-id</i>	Specify the port to be configured, and enter interface configuration mode. For the supported port types, see the “IEEE 802.1x Authentication Configuration Guidelines” section on page 9-20.
Step 3	dot1x control-direction { both in }	Enable IEEE 802.1x authentication with WoL on the port, and use these keywords to configure the port as bidirectional or unidirectional. <ul style="list-style-type: none"> • both—Sets the port as bidirectional. The port cannot receive packets from or send packets to the host. By default, the port is bidirectional. • in—Sets the port as unidirectional. The port can send packets to the host but cannot receive packets from the host.

	Command	Purpose
Step 4	end	Return to privileged EXEC mode.
Step 5	show dot1x interface <i>interface-id</i>	Verify your entries.
Step 6	copy running-config startup-config	(Optional) Save your entries in the configuration file.

To disable IEEE 802.1x authentication with WoL, use the **no dot1x control-direction** interface configuration command.

This example shows how to enable IEEE 802.1x authentication with WoL and set the port as bidirectional:

```
Switch(config-if)# dot1x control-direction both
```

Configuring MAC Authentication Bypass

Beginning in privileged EXEC mode, follow these steps to enable MAC authentication bypass. This procedure is optional.

	Command	Purpose
Step 1	configure terminal	Enter global configuration mode.
Step 2	interface <i>interface-id</i>	Specify the port to be configured, and enter interface configuration mode. For the supported port types, see the “IEEE 802.1x Authentication Configuration Guidelines” section on page 9-20.
Step 3	dot1x port-control auto	Enable IEEE 802.1x authentication on the port.
Step 4	dot1x mac-auth-bypass [eap]	Enable MAC authentication bypass. (Optional) Use the eap keyword to configure the switch to use EAP for authorization.
Step 5	end	Return to privileged EXEC mode.
Step 6	show dot1x interface <i>interface-id</i>	Verify your entries.
Step 7	copy running-config startup-config	(Optional) Save your entries in the configuration file.

To disable MAC authentication bypass, use the **no dot1x mac-auth-bypass** interface configuration command.

This example shows how to enable MAC authentication bypass:

```
Switch(config-if)# dot1x mac-auth-bypass
```

Configuring NAC Layer 2 IEEE 802.1x Validation

In Cisco IOS Release 12.2(25)SED or later, you can configure NAC Layer 2 IEEE 802.1x validation, which is also referred to as IEEE 802.1x authentication with a RADIUS server.

Beginning in privileged EXEC mode, follow these steps to configure NAC Layer 2 IEEE 802.1x validation. The procedure is optional.

	Command	Purpose
Step 1	configure terminal	Enter global configuration mode.
Step 2	interface <i>interface-id</i>	Specify the port to be configured, and enter interface configuration mode.
Step 3	dot1x guest-vlan <i>vlan-id</i>	Specify an active VLAN as an IEEE 802.1x guest VLAN. The range is 1 to 4094. You can configure any active VLAN except an RSPAN VLAN, or a voice VLAN as an IEEE 802.1x guest VLAN.
Step 4	dot1x reauthentication	Enable periodic re-authentication of the client, which is disabled by default.
Step 5	dot1x timeout reauth-period { <i>seconds</i> <i>server</i> }	Set the number of seconds between re-authentication attempts. The keywords have these meanings: <ul style="list-style-type: none"> <i>seconds</i>—Sets the number of seconds from 1 to 65535; the default is 3600 seconds. <i>server</i>—Sets the number of seconds based on the value of the Session-Timeout RADIUS attribute (Attribute[27]) and the Termination-Action RADIUS attribute (Attribute [29]). This command affects the behavior of the switch only if periodic re-authentication is enabled.
Step 6	end	Return to privileged EXEC mode.
Step 7	show dot1x interface <i>interface-id</i>	Verify your IEEE 802.1x authentication configuration.
Step 8	copy running-config startup-config	(Optional) Save your entries in the configuration file.

This example shows how to configure NAC Layer 2 IEEE 802.1x validation:

```
Switch# configure terminal
Switch(config)# interface gigabitethernet0/1
Switch(config-if)# dot1x reauthentication
Switch(config-if)# dot1x timeout reauth-period server
```

Configuring Web Authentication

Beginning in privileged EXEC mode, follow these steps to configure authentication, authorization, accounting (AAA) and RADIUS on a switch before configuring web authentication. The steps enable AAA by using RADIUS authentication and enable device tracking.

	Command	Purpose
Step 1	<code>configure terminal</code>	Enter global configuration mode.
Step 2	<code>aaa new-model</code>	Enable AAA.
Step 3	<code>aaa authentication login default group radius</code>	<p>Use RADIUS authentication. Before you can use this authentication method, you must configure the RADIUS server. For more information, see Chapter 8, “Configuring Switch-Based Authentication.”</p> <p>The console prompts you for a username and password on future attempts to access the switch console after entering the aaa authentication login command. If you do not want to be prompted for a username and password, configure a second login authentication list:</p> <pre>Switch# config t Switch(config)# aaa authentication login line-console none Switch(config)# line console 0 Switch(config-line)# login authentication line-console Switch(config-line)# end</pre>
Step 4	<code>aaa authorization auth-proxy default group radius</code>	Use RADIUS for authentication-proxy (auth-proxy) authorization.
Step 5	<code>radius-server host key radius-key</code>	Specify the authentication and encryption key for RADIUS communication between the switch and the RADIUS daemon.
Step 6	<code>radius-server attribute 8 include-in-access-req</code>	Configure the switch to send the Framed-IP-Address RADIUS attribute (Attribute[8]) in access-request or accounting-request packets.
Step 7	<code>radius-server vsa send authentication</code>	Configure the network access server to recognize and use vendor-specific attributes (VSAs).
Step 8	<code>ip device tracking</code>	<p>Enable the IP device tracking table.</p> <p>To disable the IP device tracking table, use the no ip device tracking global configuration commands.</p>
Step 9	<code>end</code>	Return to privileged EXEC mode.

This example shows how to enable AAA, use RADIUS authentication and enable device tracking:

```
Switch(config) configure terminal
Switch(config)# aaa new-model
Switch(config)# aaa authentication login default group radius
Switch(config)# aaa authorization auth-proxy default group radius
Switch(config)# radius-server host 1.1.1.2 key key1
Switch(config)# radius-server attribute 8 include-in-access-req
Switch(config)# radius-server vsa send authentication
Switch(config)# ip device tracking
Switch(config) end
```

Beginning in privileged EXEC mode, follow these steps to configure a port to use web authentication:

	Command	Purpose
Step 1	configure terminal	Enter global configuration mode.
Step 2	ip admission name rule proxy http	Define a web authentication rule. Note The same rule cannot be used for both web authentication and NAC Layer 2 IP validation. For more information, see the Network Admission Control Software Configuration Guide on Cisco.com.
Step 3	interface interface-id	Specify the port to be configured, and enter interface configuration mode.
Step 4	switchport mode access	Set the port to access mode.
Step 5	ip access-group access-list in	Specify the default access control list to be applied to network traffic before web authentication.
Step 6	ip admission rule	Apply an IP admission rule to the interface.
Step 7	end	Return to privileged EXEC mode.
Step 8	show running-config interface interface-id	Verify your configuration.
Step 9	copy running-config startup-config	(Optional) Save your entries in the configuration file.

This example shows how to configure only web authentication on a switch port:

```
Switch# configure terminal
Switch(config)# ip admission name rule1 proxy http
Switch(config)# interface gigabit1/0/1
Switch(config-if)# switchport mode access
Switch(config-if)# ip access-group policy1 in
Switch(config-if)# ip admission rule1
Switch(config-if)# end
```

Beginning in privileged EXEC mode, follow these steps to configure a switch port for IEEE 802.1x authentication with web authentication as a fallback method:

	Command	Purpose
Step 1	configure terminal	Enter global configuration mode.
Step 2	ip admission name rule proxy http	Define a web authentication rule.
Step 3	fallback profile fallback-profile	Define a fallback profile to allow an IEEE 802.1x port to authenticate a client by using web authentication.
Step 4	ip access-group policy in	Specify the default access control list to apply to network traffic before web authentication.
Step 5	ip admission rule	Associate an IP admission rule with the profile, and specify that a client connecting by web authentication uses this rule.
Step 6	end	Return to privileged EXEC mode.
Step 7	interface interface-id	Specify the port to be configured, and enter interface configuration mode.
Step 8	switchport mode access	Set the port to access mode.

	Command	Purpose
Step 9	dot1x port-control auto	Enable IEEE 802.1x authentication on the interface.
Step 10	dot1x fallback <i>fallback-profile</i>	Configure the port to authenticate a client by using web authentication when no IEEE 802.1x supplicant is detected on the port. Any change to the fallback-profile global configuration takes effect the next time IEEE 802.1x fallback is invoked on the interface. Note Web authorization cannot be used as a fallback method for IEEE 802.1x if the port is configured for multidomain authentication.
Step 11	exit	Return to privileged EXEC mode.
Step 12	show dot1x interface <i>interface-id</i>	Verify your configuration.
Step 13	copy running-config startup-config	(Optional) Save your entries in the configuration file.

This example shows how to configure IEEE 802.1x authentication with web authentication as a fallback method.

```
Switch(config) configure terminal
Switch(config)# ip admission name rule1 proxy http
Switch(config)# fallback profile fallback1
Switch(config-fallback-profile)# ip access-group default-policy in
Switch(config-fallback-profile)# ip admission rule1
Switch(config-fallback-profile)# exit
Switch(config)# interface gigabit1/0/1
Switch(config-if)# switchport mode access
Switch(config-if)# dot1x port-control auto
Switch(config-if)# dot1x fallback fallback1
Switch(config-if)# end
```

For more information about the **dot1x fallback** command, see the command reference for this release. For more information about the **ip admission name** and **ip access-group** commands, see the [Network Admission Control Software Configuration Guide](#) on Cisco.com.

Disabling IEEE 802.1x Authentication on the Port

You can disable IEEE 802.1x authentication on the port by using the **no dot1x pae** interface configuration command.

Beginning in privileged EXEC mode, follow these steps to disable IEEE 802.1x authentication on the port. This procedure is optional.

	Command	Purpose
Step 1	configure terminal	Enter global configuration mode.
Step 2	interface <i>interface-id</i>	Specify the port to be configured, and enter interface configuration mode.
Step 3	no dot1x pae	Disable IEEE 802.1x authentication on the port.
Step 4	end	Return to privileged EXEC mode.
Step 5	show dot1x interface <i>interface-id</i>	Verify your entries.
Step 6	copy running-config startup-config	(Optional) Save your entries in the configuration file.

To configure the port as an IEEE 802.1x port access entity (PAE) authenticator, which enables IEEE 802.1x on the port but does not allow clients connected to the port to be authorized, use the **dot1x pae authenticator** interface configuration command.

This example shows how to disable IEEE 802.1x authentication on the port:

```
Switch(config)# interface gigabitethernet0/1
Switch(config-if)# no dot1x pae authenticator
```

Resetting the IEEE 802.1x Authentication Configuration to the Default Values

Beginning in privileged EXEC mode, follow these steps to reset the IEEE 802.1x authentication configuration to the default values. This procedure is optional.

	Command	Purpose
Step 1	configure terminal	Enter global configuration mode.
Step 2	interface <i>interface-id</i>	Enter interface configuration mode, and specify the port to be configured.
Step 3	dot1x default	Reset the IEEE 802.1x parameters to the default values.
Step 4	end	Return to privileged EXEC mode.
Step 5	show dot1x interface <i>interface-id</i>	Verify your entries.
Step 6	copy running-config startup-config	(Optional) Save your entries in the configuration file.

Displaying IEEE 802.1x Statistics and Status

To display IEEE 802.1x statistics for all ports, use the **show dot1x all statistics** privileged EXEC command. To display IEEE 802.1x statistics for a specific port, use the **show dot1x statistics interface** *interface-id* privileged EXEC command.

To display the IEEE 802.1x administrative and operational status for the switch, use the **show dot1x all [details | statistics | summary]** privileged EXEC command. To display the IEEE 802.1x administrative and operational status for a specific port, use the **show dot1x interface** *interface-id* privileged EXEC command.

For detailed information about the fields in these displays, see the command reference for this release.



CHAPTER 10

Configuring Interface Characteristics

This chapter defines the types of interfaces on the Catalyst 2960 switch and describes how to configure them.

The chapter consists of these sections:

- [Understanding Interface Types, page 10-1](#)
- [Using Interface Configuration Mode, page 10-4](#)
- [Configuring Ethernet Interfaces, page 10-9](#)
- [Configuring the System MTU, page 10-16](#)
- [Monitoring and Maintaining the Interfaces, page 10-18](#)



Note

For complete syntax and usage information for the commands used in this chapter, see the switch command reference for this release and the *Cisco IOS Interface Command Reference, Release 12.2* from the Cisco.com page under **Documentation > Cisco IOS Software > 12.2 Mainline > Command References**.

Understanding Interface Types

This section describes the different types of interfaces supported by the switch with references to chapters that contain more detailed information about configuring these interface types. The rest of the chapter describes configuration procedures for physical interface characteristics.

These sections describe the interface types:

- [Port-Based VLANs, page 10-2](#)
- [Switch Ports, page 10-2](#)
- [EtherChannel Port Groups, page 10-3](#)
- [Dual-Purpose Uplink Ports, page 10-4](#)
- [Connecting Interfaces, page 10-4](#)

Port-Based VLANs

A VLAN is a switched network that is logically segmented by function, team, or application, without regard to the physical location of the users. For more information about VLANs, see [Chapter 12, “Configuring VLANs.”](#) Packets received on a port are forwarded only to ports that belong to the same VLAN as the receiving port. Network devices in different VLANs cannot communicate with one another without a Layer 3 device to route traffic between the VLANs.

VLAN partitions provide hard firewalls for traffic in the VLAN, and each VLAN has its own MAC address table. A VLAN comes into existence when a local port is configured to be associated with the VLAN, when the VLAN Trunking Protocol (VTP) learns of its existence from a neighbor on a trunk, or when a user creates a VLAN.

To configure normal-range VLANs (VLAN IDs 1 to 1005), use the `vlan vlan-id` global configuration command to enter config-vlan mode or the `vlan database` privileged EXEC command to enter VLAN database configuration mode. The VLAN configurations for VLAN IDs 1 to 1005 are saved in the VLAN database. To configure extended-range VLANs (VLAN IDs 1006 to 4094), you must use config-vlan mode with VTP mode set to transparent. Extended-range VLANs are not added to the VLAN database. When VTP mode is transparent, the VTP and VLAN configuration is saved in the switch running configuration, and you can save it in the switch startup configuration file by entering the `copy running-config startup-config` privileged EXEC command.

Add ports to a VLAN by using the `switchport` interface configuration commands:

- Identify the interface.
- For a trunk port, set trunk characteristics, and if desired, define the VLANs to which it can belong.
- For an access port, set and define the VLAN to which it belongs.

Switch Ports

Switch ports are Layer 2-only interfaces associated with a physical port. Switch ports belong to one or more VLANs. A switch port can be an access port or a trunk port. You can configure a port as an access port or trunk port or let the Dynamic Trunking Protocol (DTP) operate on a per-port basis to set the switchport mode by negotiating with the port on the other end of the link. Switch ports are used for managing the physical interface and associated Layer 2 protocols.

Configure switch ports by using the `switchport` interface configuration commands.

For detailed information about configuring access port and trunk port characteristics, see [Chapter 12, “Configuring VLANs.”](#)

Access Ports

An access port belongs to and carries the traffic of only one VLAN (unless it is configured as a voice VLAN port). Traffic is received and sent in native formats with no VLAN tagging. Traffic arriving on an access port is assumed to belong to the VLAN assigned to the port. If an access port receives a tagged packet (IEEE 802.1Q tagged), the packet is dropped, and the source address is not learned.

Two types of access ports are supported:

- Static access ports are manually assigned to a VLAN (or through a RADIUS server for use with IEEE 802.1x. For more information, see the [“Using IEEE 802.1x Authentication with VLAN Assignment”](#) section on page 9-9.)
- VLAN membership of dynamic access ports is learned through incoming packets. By default, a dynamic access port is not a member of any VLAN, and forwarding to and from the port is enabled only when the VLAN membership of the port is discovered. Dynamic access ports on the switch are assigned to a VLAN by a VLAN Membership Policy Server (VMPS). The VMPS can be a Catalyst 6500 series switch; the Catalyst 2960 switch cannot be a VMPS server.

You can also configure an access port with an attached Cisco IP Phone to use one VLAN for voice traffic and another VLAN for data traffic from a device attached to the phone. For more information about voice VLAN ports, see [Chapter 14, “Configuring Voice VLAN.”](#)

Trunk Ports

A trunk port carries the traffic of multiple VLANs and by default is a member of all VLANs in the VLAN database. Only IEEE 802.1Q trunk ports are supported.

An IEEE 802.1Q trunk port supports simultaneous tagged and untagged traffic. An IEEE 802.1Q trunk port is assigned a default port VLAN ID (PVID), and all untagged traffic travels on the port default PVID. All untagged traffic and tagged traffic with a NULL VLAN ID are assumed to belong to the port default PVID. A packet with a VLAN ID equal to the outgoing port default PVID is sent untagged. All other traffic is sent with a VLAN tag.

Although by default, a trunk port is a member of every VLAN known to the VTP, you can limit VLAN membership by configuring an allowed list of VLANs for each trunk port. The list of allowed VLANs does not affect any other port but the associated trunk port. By default, all possible VLANs (VLAN ID 1 to 4094) are in the allowed list. A trunk port can become a member of a VLAN only if VTP knows of the VLAN and if the VLAN is in the enabled state. If VTP learns of a new, enabled VLAN and the VLAN is in the allowed list for a trunk port, the trunk port automatically becomes a member of that VLAN and traffic is forwarded to and from the trunk port for that VLAN. If VTP learns of a new, enabled VLAN that is not in the allowed list for a trunk port, the port does not become a member of the VLAN, and no traffic for the VLAN is forwarded to or from the port.

For more information about trunk ports, see [Chapter 12, “Configuring VLANs.”](#)

EtherChannel Port Groups

EtherChannel port groups treat multiple switch ports as one switch port. These port groups act as a single logical port for high-bandwidth connections between switches or between switches and servers. An EtherChannel balances the traffic load across the links in the channel. If a link within the EtherChannel fails, traffic previously carried over the failed link changes to the remaining links. You can group multiple trunk ports into one logical trunk port or multiple access ports into one logical access port. Most protocols operate over either single ports or aggregated switch ports and do not recognize the physical ports within the port group. Exceptions are the DTP, the Cisco Discovery Protocol (CDP), and the Port Aggregation Protocol (PAgP), which operate only on physical ports.

When you configure an EtherChannel, you create a port-channel logical interface and assign an interface to the EtherChannel. Use the **channel-group** interface configuration command to dynamically create the port-channel logical interface. This command binds the physical and logical ports together. For more information, see [Chapter 31, “Configuring EtherChannels and Link-State Tracking.”](#)

Dual-Purpose Uplink Ports

Some Catalyst 2960 switches support dual-purpose uplink ports. Each uplink port is considered as a single interface with dual front ends—an RJ-45 connector and an small form-factor pluggable (SFP) module connector. The dual front ends are not redundant interfaces, and the switch activates only one connector of the pair.

By default, the switch dynamically selects the interface type that first links up. However, you can use the **media-type** interface configuration command to manually select the RJ-45 connector or the SFP module connector. For information about configuring speed and duplex settings for a dual-purpose uplink, see the “[Setting the Interface Speed and Duplex Parameters](#)” section on page 10-13.

Each uplink port has two LEDs: one shows the status of the RJ-45 port, and one shows the status of the SFP module port. The port LED is on for whichever connector is active. For more information about the LEDs, see the hardware installation guide.

Connecting Interfaces

Devices within a single VLAN can communicate directly through any switch. Ports in different VLANs cannot exchange data without going through a routing device. In the configuration shown in [Figure 10-1](#), when Host A in VLAN 20 sends data to Host B in VLAN 30, the data must go from Host A to the switch, to the router, back to the switch, and then to Host B.

Figure 10-1 Connecting VLANs with Layer 2 Switches

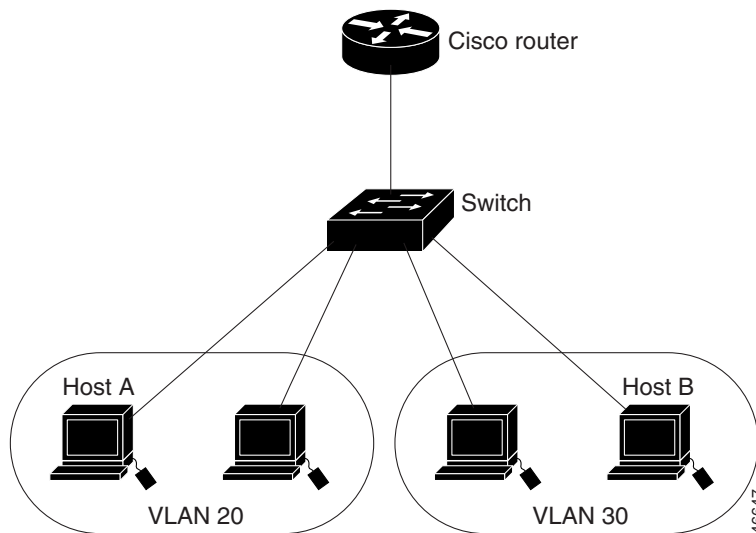

Using Interface Configuration Mode

The switch supports these interface types:

- Physical ports—switch ports
- VLANs—switch virtual interfaces
- Port channels—EtherChannel interfaces

You can also configure a range of interfaces (see the “[Configuring a Range of Interfaces](#)” section on page 10-6).

To configure a physical interface (port), specify the interface type, module number, and switch port number, and enter interface configuration mode.

- **Type**—Fast Ethernet (fastethernet or fa) for 10/100 Mb/s Ethernet, Gigabit Ethernet (gigabitethernet or gi) for 10/100/1000 Mb/s Ethernet ports, or small form-factor pluggable (SFP) module Gigabit Ethernet interfaces.
- **Module number**—The module or slot number on the switch (always 0 on the Catalyst 2960 switch).
- **Port number**—The interface number on the switch. The port numbers always begin at 1, starting with the far left port when facing the front of the switch, for example, fastethernet0/1 or gigabitethernet0/1. If there is more than one interface type (for example, 10/100 ports and SFP module ports, the port numbers restart with the second interface type: gigabitethernet0/1. For a switch with 10/100/1000 ports and SFP module ports, SFP module ports are numbered consecutively following the 10/100/1000 ports.

You can identify physical interfaces by physically checking the interface location on the switch. You can also use the **show** privileged EXEC commands to display information about a specific interface or all the interfaces on the switch. The remainder of this chapter primarily provides physical interface configuration procedures.

Procedures for Configuring Interfaces

These general instructions apply to all interface configuration processes.

Step 1 Enter the **configure terminal** command at the privileged EXEC prompt:

```
Switch# configure terminal  
Enter configuration commands, one per line. End with CNTL/Z.  
Switch(config)#
```

Step 2 Enter the **interface** global configuration command. Identify the interface type and the number of the connector. In this example, Gigabit Ethernet port 1 is selected:

```
Switch(config)# interface gigabitethernet0/1  
Switch(config-if)#
```



Note You do not need to add a space between the interface type and interface number. For example, in the preceding line, you can specify either **gigabitethernet 0/1**, **gigabitethernet0/1**, **gi 0/1**, or **gi0/1**.

Step 3 Follow each **interface** command with the interface configuration commands that the interface requires. The commands that you enter define the protocols and applications that will run on the interface. The commands are collected and applied to the interface when you enter another interface command or enter **end** to return to privileged EXEC mode.

You can also configure a range of interfaces by using the **interface range** or **interface range macro** global configuration commands. Interfaces configured in a range must be the same type and must be configured with the same feature options.

- Step 4** After you configure an interface, verify its status by using the **show** privileged EXEC commands listed in the “[Monitoring and Maintaining the Interfaces](#)” section on page 10-18.

Enter the **show interfaces** privileged EXEC command to see a list of all interfaces on or configured for the switch. A report is provided for each interface that the device supports or for the specified interface.

Configuring a Range of Interfaces

You can use the **interface range** global configuration command to configure multiple interfaces with the same configuration parameters. When you enter the interface-range configuration mode, all command parameters that you enter are attributed to all interfaces within that range until you exit this mode.

Beginning in privileged EXEC mode, follow these steps to configure a range of interfaces with the same parameters:

	Command	Purpose
Step 1	configure terminal	Enter global configuration mode.
Step 2	interface range { <i>port-range</i> macro <i>macro_name</i> }	Specify the range of interfaces (VLANs or physical ports) to be configured, and enter interface-range configuration mode. <ul style="list-style-type: none"> You can use the interface range command to configure up to five port ranges or a previously defined macro. The macro variable is explained in the “Configuring and Using Interface Range Macros” section on page 10-7. In a comma-separated <i>port-range</i>, you must enter the interface type for each entry and enter spaces before and after the comma. In a hyphen-separated <i>port-range</i>, you do not need to re-enter the interface type, but you must enter a space before the hyphen.
Step 3		Use the normal configuration commands to apply the configuration parameters to all interfaces in the range. Each command is executed as it is entered.
Step 4	end	Return to privileged EXEC mode.
Step 5	show interfaces [<i>interface-id</i>]	Verify the configuration of the interfaces in the range.
Step 6	copy running-config startup-config	(Optional) Save your entries in the configuration file.

When using the **interface range** global configuration command, note these guidelines:

- Valid entries for *port-range*:
 - vlan** *vlan-ID*, where the VLAN ID is 1 to 4094



Note Although the command-line interface shows options to set multiple VLANs, these options are not supported.

- fastethernet** module/{*first port*} - {*last port*}, where the module is always 0

- **gigabitethernet** module/{*first port*} - {*last port*}, where the module is always 0
- **port-channel** *port-channel-number* - *port-channel-number*, where the *port-channel-number* is 1 to 6



Note When you use the **interface range** command with port channels, the first and last port-channel number must be active port channels.

- You must add a space between the first interface number and the hyphen when using the **interface range** command. For example, the command **interface range gigabitethernet0/1 - 4** is a valid range; the command **interface range gigabitethernet0/1-4** is not a valid range.
- The **interface range** command only works with VLAN interfaces that have been configured with the **interface vlan** command. The **show running-config** privileged EXEC command displays the configured VLAN interfaces. VLAN interfaces not displayed by the **show running-config** command cannot be used with the **interface range** command.
- All interfaces defined in a range must be the same type (all Fast Ethernet ports, all Gigabit Ethernet ports, all EtherChannel ports, or all VLANs), but you can enter multiple ranges in a command.

This example shows how to use the **interface range** global configuration command to set the speed on ports 1 to 4 to 100 Mb/s:

```
Switch# configure terminal
Switch(config)# interface range gigabitethernet0/1 - 4
Switch(config-if-range)# speed 100
```

This example shows how to use a comma to add different interface type strings to the range to enable Fast Ethernet ports 1 to 3 and Gigabit Ethernet ports 1 and 2 to receive flow-control pause frames:

```
Switch# configure terminal
Switch(config)# interface range fastethernet0/1 - 3 , gigabitethernet0/1 - 2
Switch(config-if-range)# flowcontrol receive on
```

If you enter multiple configuration commands while you are in interface-range mode, each command is executed as it is entered. The commands are not batched and executed after you exit interface-range mode. If you exit interface-range configuration mode while the commands are being executed, some commands might not be executed on all interfaces in the range. Wait until the command prompt reappears before exiting interface-range configuration mode.

Configuring and Using Interface Range Macros

You can create an interface range macro to automatically select a range of interfaces for configuration. Before you can use the **macro** keyword in the **interface range macro** global configuration command string, you must use the **define interface-range** global configuration command to define the macro.

Beginning in privileged EXEC mode, follow these steps to define an interface range macro:

	Command	Purpose
Step 1	configure terminal	Enter global configuration mode.
Step 2	define interface-range <i>macro_name</i> <i>interface-range</i>	Define the interface-range macro, and save it in NVRAM. <ul style="list-style-type: none"> The <i>macro_name</i> is a 32-character maximum character string. A macro can contain up to five comma-separated interface ranges. Each <i>interface-range</i> must consist of the same port type.
Step 3	interface range macro <i>macro_name</i>	Select the interface range to be configured using the values saved in the interface-range macro called <i>macro_name</i> . You can now use the normal configuration commands to apply the configuration to all interfaces in the defined macro.
Step 4	end	Return to privileged EXEC mode.
Step 5	show running-config include define	Show the defined interface range macro configuration.
Step 6	copy running-config startup-config	(Optional) Save your entries in the configuration file.

Use the **no define interface-range** *macro_name* global configuration command to delete a macro.

When using the **define interface-range** global configuration command, note these guidelines:

- Valid entries for *interface-range*:
 - vlan** *vlan-ID*, where the VLAN ID is 1 to 4094



Note Although the command-line interface shows options to set multiple VLANs, these options are not supported.

- fastethernet** module/{*first port*} - {*last port*}, where the module is always 0
- gigabitethernet** module/{*first port*} - {*last port*}, where the module is always 0
- port-channel** *port-channel-number* - *port-channel-number*, where the *port-channel-number* is 1 to 6.



Note When you use the interface ranges with port channels, the first and last port-channel number must be active port channels.

- You must add a space between the first interface number and the hyphen when entering an *interface-range*. For example, **gigabitethernet0/1 - 4** is a valid range; **gigabitethernet0/1-4** is not a valid range.
- The VLAN interfaces must have been configured with the **interface vlan** command. The **show running-config** privileged EXEC command displays the configured VLAN interfaces. VLAN interfaces not displayed by the **show running-config** command cannot be used as *interface-ranges*.
- All interfaces defined as in a range must be the same type (all Fast Ethernet ports, all Gigabit Ethernet ports, all EtherChannel ports, or all VLANs), but you can combine multiple interface types in a macro.

This example shows how to define an interface-range named *enet_list* to include ports 1 and 2 and to verify the macro configuration:

```
Switch# configure terminal
Switch(config)# define interface-range enet_list gigabitethernet0/1 - 2
Switch(config)# end
Switch# show running-config | include define
define interface-range enet_list GigabitEthernet0/1 - 2
```

This example shows how to create a multiple-interface macro named *macro1*:

```
Switch# configure terminal
Switch(config)# define interface-range macro1 fastethernet0/1 - 2, gigabitethernet0/1 - 2
Switch(config)# end
```

This example shows how to enter interface-range configuration mode for the interface-range macro *enet_list*:

```
Switch# configure terminal
Switch(config)# interface range macro enet_list
Switch(config-if-range)#
```

This example shows how to delete the interface-range macro *enet_list* and to verify that it was deleted.

```
Switch# configure terminal
Switch(config)# no define interface-range enet_list
Switch(config)# end
Switch# show run | include define
Switch#
```

Configuring Ethernet Interfaces

These sections contain this configuration information:

- [Default Ethernet Interface Configuration, page 10-9](#)
- [Setting the Type of a Dual-Purpose Uplink Port, page 10-10](#)
- [Configuring Interface Speed and Duplex Mode, page 10-12](#)
- [Configuring IEEE 802.3x Flow Control, page 10-14](#)
- [Configuring Auto-MDIX on an Interface, page 10-15](#)
- [Adding a Description for an Interface, page 10-16](#)

Default Ethernet Interface Configuration

Table 10-1 shows the Ethernet interface default configuration. For more details on the VLAN parameters listed in the table, see [Chapter 12, “Configuring VLANs.”](#) For details on controlling traffic to the port, see [Chapter 19, “Configuring Port-Based Traffic Control.”](#)

Table 10-1 Default Layer 2 Ethernet Interface Configuration

Feature	Default Setting
Allowed VLAN range	VLANs 1 to 4094.
Default VLAN (for access ports)	VLAN 1.

Table 10-1 Default Layer 2 Ethernet Interface Configuration (continued)

Feature	Default Setting
Native VLAN (for IEEE 802.1Q trunks)	VLAN 1.
VLAN trunking	Switchport mode dynamic auto (supports DTP).
Port enable state	All ports are enabled.
Port description	None defined.
Speed	Autonegotiate.
Duplex mode	Autonegotiate.
Flow control	Flow control is set to receive: off . It is always off for sent packets.
EtherChannel (PAgP)	Disabled on all Ethernet ports. See Chapter 31, “Configuring EtherChannels and Link-State Tracking.”
Port blocking (unknown multicast and unknown unicast traffic)	Disabled (not blocked). See the “Configuring Port Blocking” section on page 19-7.
Broadcast, multicast, and unicast storm control	Disabled. See the “Default Storm Control Configuration” section on page 19-3.
Protected port	Disabled. See the “Configuring Protected Ports” section on page 19-5.
Port security	Disabled. See the “Default Port Security Configuration” section on page 19-10.
Port Fast	Disabled. See the “Default Optional Spanning-Tree Configuration” section on page 17-9.
Auto-MDIX	Enabled. Note The switch might not support a pre-standard powered device—such as Cisco IP phones and access points that do not fully support IEEE 802.3af—if that powered device is connected to the switch through a crossover cable. This is regardless of whether auto-MIDX is enabled on the switch port.
Keepalive messages	Disabled on SFP module ports; enabled on all other ports.

Setting the Type of a Dual-Purpose Uplink Port

Some Catalyst 2960 switches support dual-purpose uplink ports. For more information, see the [“Dual-Purpose Uplink Ports” section on page 10-4.](#)

Beginning in privileged EXEC mode, follow these steps to select which dual-purpose uplink to activate so that you can set the speed and duplex. This procedure is optional.

	Command	Purpose
Step 1	configure terminal	Enter global configuration mode.
Step 2	interface interface-id	Specify the dual-purpose uplink port to be configured, and enter interface configuration mode.

	Command	Purpose
Step 3	<code>media-type { auto-select rj45 sfp }</code>	<p>Select the interface and type of a dual-purpose uplink port. The keywords have these meanings:</p> <ul style="list-style-type: none"> • auto-select—The switch dynamically selects the type. When link up is achieved, the switch disables the other type until the active link goes down. When the active link goes down, the switch enables both types until one of them links up. In auto-select mode, the switch configures both types with autonegotiation of speed and duplex (the default). Depending on the type of installed SFP module, the switch might not be able to dynamically select it. For more information, see the information that follows this procedure. • rj45—The switch disables the SFP module interface. If you connect a cable to this port, it cannot attain a link even if the RJ-45 side is down or is not connected. In this mode, the dual-purpose port behaves like a 10/100/1000BASE-TX interface. You can configure the speed and duplex settings consistent with this interface type. • sfp—The switch disables the RJ-45 interface. If you connect a cable to this port, it cannot attain a link even if the SFP module side is down or if the SFP module is not present. Based on the type of installed SFP module, you can configure the speed and duplex settings consistent with this interface type. <p>For information about setting the speed and duplex, see the “Speed and Duplex Configuration Guidelines” section on page 10-12.</p>
Step 4	<code>end</code>	Return to privileged EXEC mode.
Step 5	<code>show interfaces interface-id transceiver properties</code>	Verify your setting.
Step 6	<code>copy running-config startup-config</code>	(Optional) Save your entries in the configuration file.

To return to the default setting, use the **no media-type** interface configuration command.

When you change the interface type, the speed and duplex configurations are removed. The switch configures both types to autonegotiate speed and duplex (the default). If you configure **auto-select**, you cannot configure the **speed** and **duplex** interface configuration commands.

When the switch powers on or when you enable a dual-purpose uplink port through the **shutdown** and the **no shutdown** interface configuration commands, the switch gives preference to the SFP module interface. In all other situations, the switch selects the active link based on which type first links up.

The Catalyst 2960 switch operates with 100BASE-*x* (where *-x* is -BX, -FX-FE, -LX) SFP modules as follows:

- When the 100BASE-*x* SFP module is inserted into the module slot and there is no link on the RJ-45 side, the switch disables the RJ-45 interface and selects the SFP module interface. This is the behavior even if there is no cable connected and if there is no link on the SFP module side.
- When the 100BASE-*x* SFP module is inserted and there is a link on the RJ-45 side, the switch continues with that link. If the link goes down, the switch disables the RJ-45 side and selects the SFP module interface.
- When the 100BASE-*x* SFP module is removed, the switch again dynamically selects the type (**auto-select**) and re-enables the RJ-45 side.

The switch does not have this behavior with 100BASE-FX-GE SFP modules.

Configuring Interface Speed and Duplex Mode

Ethernet interfaces on the switch operate at 10, 100, or 1000 Mb/s and in either full- or half-duplex mode. In full-duplex mode, two stations can send and receive traffic at the same time. Normally, 10-Mb/s ports operate in half-duplex mode, which means that stations can either receive or send traffic.

Switch models include combinations of Fast Ethernet (10/100-Mb/s) ports, Gigabit Ethernet (10/100/1000-Mb/s) ports, and small form-factor pluggable (SFP) module slots supporting SFP modules.

These sections describe how to configure the interface speed and duplex mode:

- [Speed and Duplex Configuration Guidelines, page 10-12](#)
- [Setting the Interface Speed and Duplex Parameters, page 10-13](#)

Speed and Duplex Configuration Guidelines

When configuring an interface speed and duplex mode, note these guidelines:

- Fast Ethernet (10/100-Mb/s) ports support all speed and duplex options.
- Gigabit Ethernet (10/100/1000-Mb/s) ports support all speed options and all duplex options (auto, half, and full). However, Gigabit Ethernet ports operating at 1000 Mb/s do not support half-duplex mode.
- For SFP module ports, the speed and duplex CLI options change depending on the SFP module type:
 - The 1000BASE-*x* (where *x* is -BX, -CWDM, -LX, -SX, and -ZX) SFP module ports support the **nonegotiate** keyword in the **speed** interface configuration command. Duplex options are not supported.
 - The 1000BASE-T SFP module ports support the same speed and duplex options as the 10/100/1000-Mb/s ports.
 - The 100BASE-*x* (where *x* is -BX, -CWDM, -LX, -SX, and -ZX) SFP module ports support only 100 Mb/s. These modules support full- and half- duplex options but do not support autonegotiation.

For information about which SFP modules are supported on your switch, see the product release notes.

- If both ends of the line support autonegotiation, we highly recommend the default setting of **auto** negotiation.
- If one interface supports autonegotiation and the other end does not, configure duplex and speed on both interfaces; do not use the **auto** setting on the supported side.
- When STP is enabled and a port is reconfigured, the switch can take up to 30 seconds to check for loops. The port LED is amber while STP reconfigures.



Caution

Changing the interface speed and duplex mode configuration might shut down and re-enable the interface during the reconfiguration.

Setting the Interface Speed and Duplex Parameters

Beginning in privileged EXEC mode, follow these steps to set the speed and duplex mode for a physical interface:

	Command	Purpose
Step 1	<code>configure terminal</code>	Enter global configuration mode.
Step 2	<code>interface interface-id</code>	Specify the physical interface to be configured, and enter interface configuration mode.
Step 3	<code>speed { 10 100 1000 auto [10 100 1000] nonegotiate }</code>	<p>Enter the appropriate speed parameter for the interface:</p> <ul style="list-style-type: none"> Enter 10, 100, or 1000 to set a specific speed for the interface. The 1000 keyword is available only for 10/100/1000 Mb/s ports. Enter auto to enable the interface to autonegotiate speed with the connected device. If you use the 10, 100, or the 1000 keywords with the auto keyword, the port autonegotiates only at the specified speeds. The nonegotiate keyword is available only for SFP module ports. SFP module ports operate only at 1000 Mb/s but can be configured to not negotiate if connected to a device that does not support autonegotiation. <p>For more information about speed settings, see the “Speed and Duplex Configuration Guidelines” section on page 10-12.</p>
Step 4	<code>duplex { auto full half }</code>	<p>Enter the duplex parameter for the interface.</p> <p>Enable half-duplex mode (for interfaces operating only at 10 or 100 Mb/s). You cannot configure half-duplex mode for interfaces operating at 1000 Mb/s.</p> <p>For more information about duplex settings, see the “Speed and Duplex Configuration Guidelines” section on page 10-12.</p>
Step 5	<code>end</code>	Return to privileged EXEC mode.
Step 6	<code>show interfaces interface-id</code>	Display the interface speed and duplex mode configuration.
Step 7	<code>copy running-config startup-config</code>	(Optional) Save your entries in the configuration file.

Use the **no speed** and **no duplex** interface configuration commands to return the interface to the default speed and duplex settings (autonegotiate). To return all interface settings to the defaults, use the **default interface interface-id** interface configuration command.

This example shows how to set the interface speed to 10 Mb/s and the duplex mode to half on a 10/100 Mb/s port:

```
Switch# configure terminal
Switch(config)# interface fasttetherenet0/3
Switch(config-if)# speed 10
Switch(config-if)# duplex half
```

This example shows how to set the interface speed to 100 Mb/s on a 10/100/1000 Mb/s port:

```
Switch# configure terminal
Switch(config)# interface gigabitetherenet0/2
Switch(config-if)# speed 100
```

**Note**

For interfaces gi0/1 to gi0/16, speed and duplex settings do not apply, as they are only internal server-facing interfaces. For interfaces 17 to 20, speed and duplex do not apply when they are operating in SFP module mode. For interfaces gi0/23 and gi0/24, speed and duplex do not apply when configured for media-type internal. For more information, see the [“Access Ports” section on page 10-2](#).

Configuring IEEE 802.3x Flow Control

Flow control enables connected Ethernet ports to control traffic rates during congestion by allowing congested nodes to pause link operation at the other end. If one port experiences congestion and cannot receive any more traffic, it notifies the other port by sending a pause frame to stop sending until the condition clears. Upon receipt of a pause frame, the sending device stops sending any data packets, which prevents any loss of data packets during the congestion period.

**Note**

Catalyst 2960 ports can receive, but not send, pause frames.

You use the **flowcontrol** interface configuration command to set the interface’s ability to **receive** pause frames to **on**, **off**, or **desired**. The default state is **off**.

When set to **desired**, an interface can operate with an attached device that is required to send flow-control packets or with an attached device that is not required to but can send flow-control packets.

These rules apply to flow control settings on the device:

- **receive on** (or **desired**): The port cannot send pause frames but can operate with an attached device that is required to or can send pause frames; the port can receive pause frames.
- **receive off**: Flow control does not operate in either direction. In case of congestion, no indication is given to the link partner, and no pause frames are sent or received by either device.

**Note**

For details on the command settings and the resulting flow control resolution on local and remote ports, see the **flowcontrol** interface configuration command in the command reference for this release.

Beginning in privileged EXEC mode, follow these steps to configure flow control on an interface:

	Command	Purpose
Step 1	configure terminal	Enter global configuration mode
Step 2	interface <i>interface-id</i>	Specify the physical interface to be configured, and enter interface configuration mode.
Step 3	flowcontrol { receive } { on off desired }	Configure the flow control mode for the port.
Step 4	end	Return to privileged EXEC mode.
Step 5	show interfaces <i>interface-id</i>	Verify the interface flow control settings.
Step 6	copy running-config startup-config	(Optional) Save your entries in the configuration file.

To disable flow control, use the **flowcontrol receive off** interface configuration command.

This example shows how to turn on flow control on a port:

```
Switch# configure terminal
Switch(config)# interface gigabitethernet0/1
Switch(config-if)# flowcontrol receive on
Switch(config-if)# end
```

Configuring Auto-MDIX on an Interface

When automatic medium-dependent interface crossover (auto-MDIX) is enabled on an interface, the interface automatically detects the required cable connection type (straight through or crossover) and configures the connection appropriately. When connecting switches without the auto-MDIX feature, you must use straight-through cables to connect to devices such as servers, workstations, or routers and crossover cables to connect to other switches or repeaters. With auto-MDIX enabled, you can use either type of cable to connect to other devices, and the interface automatically corrects for any incorrect cabling. For more information about cabling requirements, see the hardware installation guide.

Auto-MDIX is enabled by default. When you enable auto-MDIX, you must also set the interface speed and duplex to **auto** so that the feature operates correctly. Auto-MDIX is supported on all 10/100 and 10/100/1000-Mb/s interfaces. It is not supported on 1000BASE-SX or -LX SFP module interfaces.

Table 10-2 shows the link states that result from auto-MDIX settings and correct and incorrect cabling.

Table 10-2 Link Conditions and Auto-MDIX Settings

Local Side Auto-MDIX	Remote Side Auto-MDIX	With Correct Cabling	With Incorrect Cabling
On	On	Link up	Link up
On	Off	Link up	Link up
Off	On	Link up	Link up
Off	Off	Link up	Link down

Beginning in privileged EXEC mode, follow these steps to configure auto-MDIX on an interface:

	Command	Purpose
Step 1	configure terminal	Enter global configuration mode
Step 2	interface <i>interface-id</i>	Specify the physical interface to be configured, and enter interface configuration mode.
Step 3	speed auto	Configure the interface to autonegotiate speed with the connected device.
Step 4	duplex auto	Configure the interface to autonegotiate duplex mode with the connected device.
Step 5	mdix auto	Enable auto-MDIX on the interface.
Step 6	end	Return to privileged EXEC mode.
Step 7	show controllers ethernet-controller <i>interface-id</i> phy	Verify the operational state of the auto-MDIX feature on the interface.
Step 8	copy running-config startup-config	(Optional) Save your entries in the configuration file.

To disable auto-MDIX, use the **no mdix auto** interface configuration command.

This example shows how to enable auto-MDIX on a port:

```
Switch# configure terminal
Switch(config)# interface gigabitethernet0/1
Switch(config-if)# speed auto
Switch(config-if)# duplex auto
Switch(config-if)# mdix auto
Switch(config-if)# end
```

Adding a Description for an Interface

You can add a description about an interface to help you remember its function. The description appears in the output of these privileged EXEC commands: **show configuration**, **show running-config**, and **show interfaces**.

Beginning in privileged EXEC mode, follow these steps to add a description for an interface:

	Command	Purpose
Step 1	configure terminal	Enter global configuration mode.
Step 2	interface <i>interface-id</i>	Specify the interface for which you are adding a description, and enter interface configuration mode.
Step 3	description <i>string</i>	Add a description (up to 240 characters) for an interface.
Step 4	end	Return to privileged EXEC mode.
Step 5	show interfaces <i>interface-id</i> description or show running-config	Verify your entry.
Step 6	copy running-config startup-config	(Optional) Save your entries in the configuration file.

Use the **no description** interface configuration command to delete the description.

This example shows how to add a description on a port and how to verify the description:

```
Switch# config terminal
Enter configuration commands, one per line. End with CNTL/Z.
Switch(config)# interface gigabitethernet0/2
Switch(config-if)# description Connects to Marketing
Switch(config-if)# end
Switch# show interfaces gigabitethernet0/2 description
Interface Status      Protocol Description
Gi0/2    admin down    down    Connects to Marketing
```

Configuring the System MTU

The default maximum transmission unit (MTU) size for frames received and transmitted on all interfaces on the switch is 1500 bytes. You can increase the MTU size for all interfaces operating at 10 or 100 Mb/s by using the **system mtu** global configuration command. You can increase the MTU size to support jumbo frames on all Gigabit Ethernet interfaces by using the **system mtu jumbo** global configuration command.

Gigabit Ethernet ports are not affected by the **system mtu** command; 10/100 ports are not affected by the **system jumbo mtu** command. If you do not configure the **system mtu jumbo** command, the setting of the **system mtu** command applies to all Gigabit Ethernet interfaces.

You cannot set the MTU size for an individual interface; you set it for all 10/100 or all Gigabit Ethernet interfaces on the switch. When you change the system or jumbo MTU size, you must reset the switch before the new configuration takes effect.

Frames sizes that can be received by the switch CPU are limited to 1998 bytes, no matter what value was entered with the **system mtu** or **system mtu jumbo** commands. Although frames that are forwarded are typically not received by the CPU, in some cases packets are sent to the CPU, such as traffic sent to control traffic, SNMP, or Telnet.

**Note**

If Gigabit Ethernet interfaces are configured to accept frames greater than the 10/100 interfaces, jumbo frames received on a Gigabit Ethernet interface and sent on a 10/100 interface are dropped.

Beginning in privileged EXEC mode, follow these steps to change MTU size for all 10/100 or Gigabit Ethernet interfaces:

	Command	Purpose
Step 1	configure terminal	Enter global configuration mode.
Step 2	system mtu bytes	(Optional) Change the MTU size for all interfaces on the switch that are operating at 10 or 100 Mb/s. The range is 1500 to 1998 bytes; the default is 1500 bytes.
Step 3	system mtu jumbo bytes	(Optional) Change the MTU size for all Gigabit Ethernet interfaces on the switch. The range is 1500 to 9000 bytes; the default is 1500 bytes.
Step 4	end	Return to privileged EXEC mode.
Step 5	copy running-config startup-config	Save your entries in the configuration file.
Step 6	reload	Reload the operating system.

If you enter a value that is outside the allowed range for the specific type of interface, the value is not accepted.

Once the switch reloads, you can verify your settings by entering the **show system mtu** privileged EXEC command.

This example shows how to set the maximum packet size for a Gigabit Ethernet port to 1800 bytes:

```
Switch(config)# system jumbo mtu 1800
Switch(config)# exit
Switch# reload
```

This example shows the response when you try to set Gigabit Ethernet interfaces to an out-of-range number:

```
Switch(config)# system mtu jumbo 25000
                        ^
% Invalid input detected at '^' marker.
```

Monitoring and Maintaining the Interfaces

These sections contain interface monitoring and maintenance information:

- [Monitoring Interface Status, page 10-18](#)
- [Clearing and Resetting Interfaces and Counters, page 10-19](#)
- [Shutting Down and Restarting the Interface, page 10-19](#)

Monitoring Interface Status

Commands entered at the privileged EXEC prompt display information about the interface, including the versions of the software and the hardware, the configuration, and statistics about the interfaces. [Table 10-3](#) lists some of these interface monitoring commands. (You can display the full list of **show** commands by using the **show ?** command at the privileged EXEC prompt.) These commands are fully described in the *Cisco IOS Interface Command Reference, Release 12.2* from the Cisco.com page under **Documentation > Cisco IOS Software > 12.2 Mainline > Command References**.

Table 10-3 Show Commands for Interfaces

Command	Purpose
show interfaces [<i>interface-id</i>]	Display the status and configuration of all interfaces or a specific interface.
show interfaces <i>interface-id</i> status [err-disabled]	Display interface status or a list of interfaces in an error-disabled state.
show interfaces [<i>interface-id</i>] switchport	Display administrative and operational status of switching ports.
show interfaces [<i>interface-id</i>] description	Display the description configured on an interface or all interfaces and the interface status.
show ip interface [<i>interface-id</i>]	Display the usability status of all interfaces configured for IP routing or the specified interface.
show interface [<i>interface-id</i>] stats	Display the input and output packets by the switching path for the interface.
show interfaces transceiver properties	(Optional) Display speed and duplex settings on the interface.
show interfaces [<i>interface-id</i>] [{ transceiver properties detail }] [<i>module number</i>]	Display physical and operational status about an SFP module.
show running-config interface [<i>interface-id</i>]	Display the running configuration in RAM for the interface.
show version	Display the hardware configuration, software version, the names and sources of configuration files, and the boot images.
show controllers ethernet-controller <i>interface-id</i> phy	Display the operational state of the auto-MDIX feature on the interface.

Clearing and Resetting Interfaces and Counters

Table 10-4 lists the privileged EXEC mode **clear** commands that you can use to clear counters and reset interfaces.

Table 10-4 Clear Commands for Interfaces

Command	Purpose
clear counters [<i>interface-id</i>]	Clear interface counters.
clear interface <i>interface-id</i>	Reset the hardware logic on an interface.
clear line [<i>number</i> console 0 <i>vtty number</i>]	Reset the hardware logic on an asynchronous serial line.

To clear the interface counters shown by the **show interfaces** privileged EXEC command, use the **clear counters** privileged EXEC command. The **clear counters** command clears all current interface counters from the interface unless you specify optional arguments that clear only a specific interface type from a specific interface number.



Note

The **clear counters** privileged EXEC command does not clear counters retrieved by using Simple Network Management Protocol (SNMP), but only those seen with the **show interface** privileged EXEC command.

Shutting Down and Restarting the Interface

Shutting down an interface disables all functions on the specified interface and marks the interface as unavailable on all monitoring command displays. This information is communicated to other network servers through all dynamic routing protocols. The interface is not mentioned in any routing updates.

Beginning in privileged EXEC mode, follow these steps to shut down an interface:

	Command	Purpose
Step 1	configure terminal	Enter global configuration mode.
Step 2	interface { <i>vlan vlan-id</i> } {{ fastethernet gigabitethernet } <i>interface-id</i> } { port-channel <i>port-channel-number</i> }	Select the interface to be configured.
Step 3	shutdown	Shut down an interface.
Step 4	end	Return to privileged EXEC mode.
Step 5	show running-config	Verify your entry.

Use the **no shutdown** interface configuration command to restart the interface.

To verify that an interface is disabled, enter the **show interfaces** privileged EXEC command. A disabled interface is shown as *administratively down* in the display.



CHAPTER 11

Configuring Smartports Macros

This chapter describes how to configure and apply Smartports macros on the Catalyst 2960 switch.



Note

For complete syntax and usage information for the commands used in this chapter, see the command reference for this release.

This chapter consists of these sections:

- [Understanding Smartports Macros, page 11-1](#)
- [Configuring Smartports Macros, page 11-2](#)
- [Displaying Smartports Macros, page 11-8](#)

Understanding Smartports Macros

Smartports macros provide a convenient way to save and share common configurations. You can use Smartports macros to enable features and settings based on the location of a switch in the network and for mass configuration deployments across the network.

Each Smartports macro is a set of command-line interface (CLI) commands that you define. Smartports macros do not contain new CLI commands; they are simply a group of existing CLI commands.

When you apply a Smartports macro on an interface, the CLI commands within the macro are configured on the interface. When the macro is applied to an interface, the existing interface configurations are not lost. The new commands are added to the interface and are saved in the running configuration file.

There are Cisco-default Smartports macros embedded in the switch software (see [Table 11-1](#)). You can display these macros and the commands they contain by using the **show parser macro** user EXEC command.

Table 11-1 Cisco-Default Smartports Macros

Macro Name ¹	Description
cisco-global	Use this global configuration macro to enable rapid PVST+, loop guard, and dynamic port error recovery for link state failures.
cisco-desktop	Use this interface configuration macro for increased network security and reliability when connecting a desktop device, such as a PC, to a switch port.

Table 11-1 Cisco-Default Smartports Macros (continued)

Macro Name ¹	Description
cisco-phone	Use this interface configuration macro when connecting a desktop device such as a PC with a Cisco IP Phone to a switch port. This macro is an extension of the cisco-desktop macro and provides the same security and resiliency features, but with the addition of dedicated voice VLANs to ensure proper treatment of delay-sensitive voice traffic.
cisco-switch	Use this interface configuration macro when connecting an access switch and a distribution switch or between access switches connected using small form-factor pluggable (SFP) modules.
cisco-router	Use this interface configuration macro when connecting the switch and a WAN router.
cisco-wireless	Use this interface configuration macro when connecting the switch and a wireless access point.

1. Cisco-default Smartports macros vary depending on the software version running on your switch.

Cisco also provides a collection of pretested, Cisco-recommended baseline configuration templates for Catalyst switches. The online reference guide templates provide the CLI commands that you can use to create Smartports macros based on the usage of the port. You can use the configuration templates to create Smartports macros to build and deploy Cisco-recommended network designs and configurations. For more information about Cisco-recommended configuration templates, see this Smartports website:

<http://www.cisco.com/go/smartports>

Configuring Smartports Macros

You can create a new Smartports macro or use an existing macro as a template to create a new macro that is specific to your application. After you create the macro, you can apply it globally to a switch or to a switch interface or range of interfaces.

These sections contain this configuration information:

- [Default Smartports Macro Configuration, page 11-2](#)
- [Smartports Macro Configuration Guidelines, page 11-2](#)
- [Creating Smartports Macros, page 11-4](#)
- [Applying Smartports Macros, page 11-5](#)
- [Applying Cisco-Default Smartports Macros, page 11-6](#)

Default Smartports Macro Configuration

There are no Smartports macros enabled.

Smartports Macro Configuration Guidelines

Follow these guidelines when configuring macros on your switch:

- When creating a macro, do not use the **exit** or **end** commands or change the command mode by using **interface interface-id**. This could cause commands that follow **exit**, **end**, or **interface interface-id** to execute in a different command mode.
- When creating a macro, all CLI commands should be in the same configuration mode.

- When creating a macro that requires the assignment of unique values, use the **parameter value** keywords to designate values specific to the interface. Keyword matching is case sensitive. All matching occurrences of the keyword are replaced with the corresponding value. Any full match of a keyword, even if it is part of a larger string, is considered a match and is replaced by the corresponding value.
- Macro names are case sensitive. For example, the commands **macro name Sample-Macro** and **macro name sample-macro** will result in two separate macros.
- Some macros might contain keywords that require a parameter value. You can use the **macro global apply macro-name ?** global configuration command or the **macro apply macro-name ?** interface configuration command to display a list of any required values in the macro. If you apply a macro without entering the keyword values, the commands are invalid and are not applied.
- When a macro is applied globally to a switch or to a switch interface, all existing configuration on the interface is retained. This is helpful when applying an incremental configuration.
- If you modify a macro definition by adding or deleting commands, the changes are not reflected on the interface where the original macro was applied. You need to reapply the updated macro on the interface to apply the new or changed commands.
- You can use the **macro global trace macro-name** global configuration command or the **macro trace macro-name** interface configuration command to apply and debug a macro to find any syntax or configuration errors. If a command fails because of a syntax error or a configuration error, the macro continues to apply the remaining commands.
- Some CLI commands are specific to certain interface types. If a macro is applied to an interface that does not accept the configuration, the macro will fail the syntax check or the configuration check, and the switch will return an error message.
- Applying a macro to an interface range is the same as applying a macro to a single interface. When you use an interface range, the macro is applied sequentially to each interface within the range. If a macro command fails on one interface, it is still applied to the remaining interfaces.
- When you apply a macro to a switch or a switch interface, the macro name is automatically added to the switch or interface. You can display the applied commands and macro names by using the **show running-config** user EXEC command.

There are Cisco-default Smartports macros embedded in the switch software (see [Table 11-1](#)). You can display these macros and the commands they contain by using the **show parser macro** user EXEC command.

Follow these guidelines when you apply a Cisco-default Smartports macro on an interface:

- Display all macros on the switch by using the **show parser macro** user EXEC command. Display the contents of a specific macro by using the **show parser macro macro-name** user EXEC command.
- Keywords that begin with **\$** mean that a unique parameter value is required. Append the Cisco-default macro with the required values by using the **parameter value** keywords.

The Cisco-default macros use the **\$** character to help identify required keywords. There is no restriction on using the **\$** character to define keywords when you create a macro.

Creating Smartports Macros

Beginning in privileged EXEC mode, follow these steps to create a Smartports macro:

	Command	Purpose
Step 1	<code>configure terminal</code>	Enter global configuration mode.
Step 2	<code>macro name <i>macro-name</i></code>	<p>Create a macro definition, and enter a macro name. A macro definition can contain up to 3000 characters.</p> <p>Enter the macro commands with one command per line. Use the @ character to end the macro. Use the # character at the beginning of a line to enter comment text within the macro.</p> <p>(Optional) You can define keywords within a macro by using a help string to specify the keywords. Enter # macro keywords <i>word</i> to define the keywords that are available for use with the macro. Separated by a space, you can enter up to three help string keywords in a macro.</p> <p>Macro names are case sensitive. For example, the commands macro name Sample-Macro and macro name sample-macro will result in two separate macros.</p> <p>We recommend that you do not use the exit or end commands or change the command mode by using interface <i>interface-id</i> in a macro. This could cause any commands following exit, end, or interface <i>interface-id</i> to execute in a different command mode. For best results, all commands in a macro should be in the same configuration mode.</p>
Step 3	<code>end</code>	Return to privileged EXEC mode.
Step 4	<code>show parser macro name <i>macro-name</i></code>	Verify that the macro was created.

The **no** form of the **macro name** global configuration command only deletes the macro definition. It does not affect the configuration of those interfaces on which the macro is already applied.

This example shows how to create a macro that defines the switchport access VLAN and the number of secure MAC addresses and also includes two help string keywords by using # **macro keywords**:

```
Switch(config)# macro name test
switchport access vlan $VLANID
switchport port-security maximum $MAX
#macro keywords $VLANID $MAX
@
```

Applying Smartports Macros

Beginning in privileged EXEC mode, follow these steps to apply a Smartports macro:

	Command	Purpose
Step 1	configure terminal	Enter global configuration mode.
Step 2	macro global { apply trace } <i>macro-name</i> [parameter { <i>value</i> }] [parameter { <i>value</i> }] [parameter { <i>value</i> }]	<p>Apply each individual command defined in the macro to the switch by entering macro global apply <i>macro-name</i>. Specify macro global trace <i>macro-name</i> to apply and debug a macro to find any syntax or configuration errors.</p> <p>(Optional) Specify unique parameter values that are specific to the switch. You can enter up to three keyword-value pairs. Parameter keyword matching is case sensitive. All matching occurrences of the keyword are replaced with the corresponding value.</p> <p>Some macros might contain keywords that require a parameter value. You can use the macro global apply <i>macro-name</i> ? command to display a list of any required values in the macro. If you apply a macro without entering the keyword values, the commands are invalid and are not applied.</p>
Step 3	macro global description <i>text</i>	(Optional) Enter a description about the macro that is applied to the switch.
Step 4	interface <i>interface-id</i>	(Optional) Enter interface configuration mode, and specify the interface on which to apply the macro.
Step 5	default interface <i>interface-id</i>	(Optional) Clear all configuration from the specified interface.
Step 6	macro { apply trace } <i>macro-name</i> [parameter { <i>value</i> }] [parameter { <i>value</i> }] [parameter { <i>value</i> }]	<p>Apply each individual command defined in the macro to the interface by entering macro apply <i>macro-name</i>. Specify macro trace <i>macro-name</i> to apply and debug a macro to find any syntax or configuration errors.</p> <p>(Optional) Specify unique parameter values that are specific to the interface. You can enter up to three keyword-value pairs. Parameter keyword matching is case sensitive. All matching occurrences of the keyword are replaced with the corresponding value.</p> <p>Some macros might contain keywords that require a parameter value. You can use the macro apply <i>macro-name</i> ? command to display a list of any required values in the macro. If you apply a macro without entering the keyword values, the commands are invalid and are not applied.</p>
Step 7	macro description <i>text</i>	(Optional) Enter a description about the macro that is applied to the interface.
Step 8	end	Return to privileged EXEC mode.
Step 9	show parser macro description [interface <i>interface-id</i>]	Verify that the macro is applied to the interface.
Step 10	copy running-config startup-config	(Optional) Save your entries in the configuration file.

You can delete a global macro-applied configuration on a switch only by entering the **no** version of each command that is in the macro. You can delete a macro-applied configuration on an interface by entering the **default interface** *interface-id* interface configuration command.

This example shows how to apply the user-created macro called **snmp**, to set the hostname address to **test-server**, and to set the IP precedence value to **7**:

```
Switch(config)# macro global apply snmp ADDRESS test-server VALUE 7
```

This example shows how to debug the user-created macro called **snmp** by using the **macro global trace** global configuration command to find any syntax or configuration errors in the macro when it is applied to the switch.

```
Switch(config)# macro global trace snmp VALUE 7
Applying command...'snmp-server enable traps port-security'
Applying command...'snmp-server enable traps linkup'
Applying command...'snmp-server enable traps linkdown'
Applying command...'snmp-server host'
%Error Unknown error.
Applying command...'snmp-server ip precedence 7'
```

This example shows how to apply the user-created macro called **desktop-config** and to verify the configuration.

```
Switch(config)# interface gigabitethernet0/2
Switch(config-if)# macro apply desktop-config
Switch(config-if)# end
Switch# show parser macro description
Interface      Macro Description
-----
Gi0/2         desktop-config
-----
```

This example shows how to apply the user-created macro called **desktop-config** and to replace all occurrences of VLAN 1 with VLAN 25:

```
Switch(config-if)# macro apply desktop-config vlan 25
```

Applying Cisco-Default Smartports Macros

Beginning in privileged EXEC mode, follow these steps to apply a Smartports macro:

	Command	Purpose
Step 1	show parser macro	Display the Cisco-default Smartports macros embedded in the switch software.
Step 2	show parser macro <i>macro-name</i>	Display the specific macro that you want to apply.
Step 3	configure terminal	Enter global configuration mode.
Step 4	macro global { apply trace } <i>macro-name</i> [parameter { <i>value</i> }] [parameter { <i>value</i> }] [parameter { <i>value</i> }]	Append the Cisco-default macro with the required values by using the parameter value keywords and apply the macro to the switch. Keywords that begin with \$ mean that a unique parameter value is required. You can use the macro global apply macro-name ? command to display a list of any required values in the macro. If you apply a macro without entering the keyword values, the commands are invalid and are not applied.
Step 5	interface <i>interface-id</i>	(Optional) Enter interface configuration mode, and specify the interface on which to apply the macro.
Step 6	default interface <i>interface-id</i>	(Optional) Clear all configuration from the specified interface.

	Command	Purpose
Step 7	macro { apply trace } <i>macro-name</i> [parameter { <i>value</i> }] [parameter { <i>value</i> }] [parameter { <i>value</i> }]	Append the Cisco-default macro with the required values by using the parameter <i>value</i> keywords, and apply the macro to the interface. Keywords that begin with \$ mean that a unique parameter value is required. You can use the macro apply macro-name ? command to display a list of any required values in the macro. If you apply a macro without entering the keyword values, the commands are invalid and are not applied.
Step 8	end	Return to privileged EXEC mode.
Step 9	show running-config interface <i>interface-id</i>	Verify that the macro is applied to an interface.
Step 10	copy running-config startup-config	(Optional) Save your entries in the configuration file.

You can delete a global macro-applied configuration on a switch only by entering the **no** version of each command that is in the macro. You can delete a macro-applied configuration on an interface by entering the **default interface interface-id** interface configuration command.

This example shows how to display the **cisco-desktop** macro, how to apply the macro, and to set the access VLAN ID to 25 on an interface:

```
Switch# show parser macro cisco-desktop
-----
Macro name : cisco-desktop
Macro type : default

# Basic interface - Enable data VLAN only
# Recommended value for access vlan (AVID) should not be 1
switchport access vlan $AVID
switchport mode access

# Enable port security limiting port to a single
# MAC address -- that of desktop
switchport port-security
switchport port-security maximum 1

# Ensure port-security age is greater than one minute
# and use inactivity timer
switchport port-security violation restrict
switchport port-security aging time 2
switchport port-security aging type inactivity

# Configure port as an edge network port
spanning-tree portfast
spanning-tree bpduguard enable
-----
Switch#
Switch# configure terminal
Switch(config)# gigabitethernet0/4
Switch(config-if)# macro apply cisco-desktop $AVID 25
```

Displaying Smartports Macros

To display the Smartports macros, use one or more of the privileged EXEC commands in [Table 11-2](#).

Table 11-2 **Commands for Displaying Smartports Macros**

Command	Purpose
<code>show parser macro</code>	Displays all configured macros.
<code>show parser macro name <i>macro-name</i></code>	Displays a specific macro.
<code>show parser macro brief</code>	Displays the configured macro names.
<code>show parser macro description [interface <i>interface-id</i>]</code>	Displays the macro description for all interfaces or for a specified interface.



CHAPTER 12

Configuring VLANs

This chapter describes how to configure normal-range VLANs (VLAN IDs 1 to 1005) and extended-range VLANs (VLAN IDs 1006 to 4094) on the Catalyst 2960 switch. It includes information about VLAN membership modes, VLAN configuration modes, VLAN trunks, and dynamic VLAN assignment from a VLAN Membership Policy Server (VMPS).

**Note**

For complete syntax and usage information for the commands used in this chapter, see the command reference for this release.

The chapter consists of these sections:

- [Understanding VLANs, page 12-1](#)
- [Configuring Normal-Range VLANs, page 12-4](#)
- [Configuring Extended-Range VLANs, page 12-11](#)
- [Displaying VLANs, page 12-13](#)
- [Configuring VLAN Trunks, page 12-14](#)
- [Configuring VMPS, page 12-23](#)

Understanding VLANs

A VLAN is a switched network that is logically segmented by function, project team, or application, without regard to the physical locations of the users. VLANs have the same attributes as physical LANs, but you can group end stations even if they are not physically located on the same LAN segment. Any switch port can belong to a VLAN, and unicast, broadcast, and multicast packets are forwarded and flooded only to end stations in the VLAN. Each VLAN is considered a logical network, and packets destined for stations that do not belong to the VLAN must be forwarded through a router or a switch supporting fallback bridging, as shown in [Figure 12-1](#). Because a VLAN is considered a separate logical network, it contains its own bridge Management Information Base (MIB) information and can support its own implementation of spanning tree. See [Chapter 15, “Configuring STP.”](#)

**Note**

Before you create VLANs, you must decide whether to use VLAN Trunking Protocol (VTP) to maintain global VLAN configuration for your network. For more information on VTP, see [Chapter 13, “Configuring VTP.”](#)

Figure 12-1 shows an example of VLANs segmented into logically defined networks.

Figure 12-1 VLANs as Logically Defined Networks

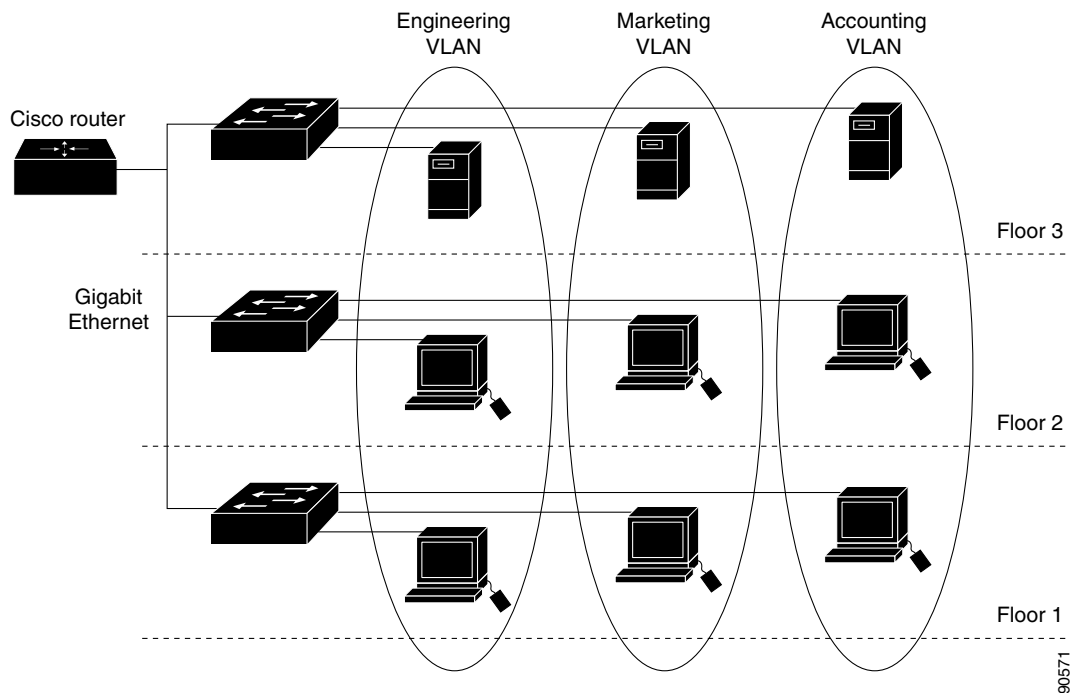

VLANs are often associated with IP subnetworks. For example, all the end stations in a particular IP subnet belong to the same VLAN. Interface VLAN membership on the switch is assigned manually on an interface-by-interface basis. When you assign switch interfaces to VLANs by using this method, it is known as interface-based, or static, VLAN membership.

Traffic between VLANs must be routed or fallback bridged.

Supported VLANs

The switch supports VLANs in VTP client, server, and transparent modes. VLANs are identified by a number from 1 to 4094. VLAN IDs 1002 through 1005 are reserved for Token Ring and FDDI VLANs. VTP only learns normal-range VLANs, with VLAN IDs 1 to 1005; VLAN IDs greater than 1005 are extended-range VLANs and are not stored in the VLAN database. The switch must be in VTP transparent mode when you create VLAN IDs from 1006 to 4094.

Although the switch supports a total of 255 (normal range and extended range) VLANs, the number of configured features affects the use of the switch hardware.

The switch supports per-VLAN spanning-tree plus (PVST+) or rapid PVST+ with a maximum of 128 spanning-tree instances. One spanning-tree instance is allowed per VLAN. See the [“Normal-Range VLAN Configuration Guidelines”](#) section on page 12-5 for more information about the number of spanning-tree instances and the number of VLANs. The switch supports only IEEE 802.1Q trunking methods for sending VLAN traffic over Ethernet ports.

VLAN Port Membership Modes

You configure a port to belong to a VLAN by assigning a membership mode that specifies the kind of traffic the port carries and the number of VLANs to which it can belong. [Table 12-1](#) lists the membership modes and membership and VTP characteristics.

Table 12-1 Port Membership Modes and Characteristics

Membership Mode	VLAN Membership Characteristics	VTP Characteristics
Static-access	<p>A static-access port can belong to one VLAN and is manually assigned to that VLAN.</p> <p>For more information, see the “Assigning Static-Access Ports to a VLAN” section on page 12-10.</p>	<p>VTP is not required. If you do not want VTP to globally propagate information, set the VTP mode to transparent. To participate in VTP, there must be at least one trunk port on the switch connected to a trunk port of a second switch.</p>
Trunk (IEEE 802.1Q)	<p>A trunk port is a member of all VLANs by default, including extended-range VLANs, but membership can be limited by configuring the allowed-VLAN list. You can also modify the pruning-eligible list to block flooded traffic to VLANs on trunk ports that are included in the list.</p> <p>For information about configuring trunk ports, see the “Configuring an Ethernet Interface as a Trunk Port” section on page 12-16.</p>	<p>VTP is recommended but not required. VTP maintains VLAN configuration consistency by managing the addition, deletion, and renaming of VLANs on a network-wide basis. VTP exchanges VLAN configuration messages with other switches over trunk links.</p>
Dynamic access	<p>A dynamic-access port can belong to one VLAN (VLAN ID 1 to 4094) and is dynamically assigned by a VMPS. The VMPS can be a Catalyst 5000 or Catalyst 6500 series switch, for example, but never a Catalyst 2960 switch. The Catalyst 2960 switch is a VMPS client.</p> <p>You can have dynamic-access ports and trunk ports on the same switch, but you must connect the dynamic-access port to an end station or hub and not to another switch.</p> <p>For configuration information, see the “Configuring Dynamic-Access Ports on VMPS Clients” section on page 12-26.</p>	<p>VTP is required.</p> <p>Configure the VMPS and the client with the same VTP domain name.</p> <p>To participate in VTP, at least one trunk port on the switch must be connected to a trunk port of a second switch.</p>
Voice VLAN	<p>A voice VLAN port is an access port attached to a Cisco IP Phone, configured to use one VLAN for voice traffic and another VLAN for data traffic from a device attached to the phone.</p> <p>For more information about voice VLAN ports, see Chapter 14, “Configuring Voice VLAN.”</p>	<p>VTP is not required; it has no affect on a voice VLAN.</p>

For more detailed definitions of access and trunk modes and their functions, see [Table 12-4](#) on page 12-15.

When a port belongs to a VLAN, the switch learns and manages the addresses associated with the port on a per-VLAN basis. For more information, see the [“Managing the MAC Address Table”](#) section on page 6-19.

Configuring Normal-Range VLANs

Normal-range VLANs are VLANs with VLAN IDs 1 to 1005. If the switch is in VTP server or VTP transparent mode, you can add, modify or remove configurations for VLANs 2 to 1001 in the VLAN database. (VLAN IDs 1 and 1002 to 1005 are automatically created and cannot be removed.)



Note

When the switch is in VTP transparent mode, you can also create extended-range VLANs (VLANs with IDs from 1006 to 4094), but these VLANs are not saved in the VLAN database. See the [“Configuring Extended-Range VLANs”](#) section on page 12-11.

Configurations for VLAN IDs 1 to 1005 are written to the file *vlan.dat* (VLAN database), and you can display them by entering the **show vlan** privileged EXEC command. The *vlan.dat* file is stored in flash memory.



Caution

You can cause inconsistency in the VLAN database if you attempt to manually delete the *vlan.dat* file. If you want to modify the VLAN configuration, use the commands described in these sections and in the command reference for this release. To change the VTP configuration, see [Chapter 13, “Configuring VTP.”](#)

You use the interface configuration mode to define the port membership mode and to add and remove ports from VLANs. The results of these commands are written to the running-configuration file, and you can display the file by entering the **show running-config** privileged EXEC command.

You can set these parameters when you create a new normal-range VLAN or modify an existing VLAN in the VLAN database:

- VLAN ID
- VLAN name
- VLAN type (Ethernet, Fiber Distributed Data Interface [FDDI], FDDI network entity title [NET], TrBRF, or TrCRF, Token Ring, Token Ring-Net)
- VLAN state (active or suspended)
- Maximum transmission unit (MTU) for the VLAN
- Security Association Identifier (SAID)
- Bridge identification number for TrBRF VLANs
- Ring number for FDDI and TrCRF VLANs
- Parent VLAN number for TrCRF VLANs
- Spanning Tree Protocol (STP) type for TrCRF VLANs
- VLAN number to use when translating from one VLAN type to another



Note

This section does not provide configuration details for most of these parameters. For complete information on the commands and parameters that control VLAN configuration, see the command reference for this release.

These sections contain normal-range VLAN configuration information:

- [Token Ring VLANs, page 12-5](#)
- [Normal-Range VLAN Configuration Guidelines, page 12-5](#)
- [VLAN Configuration Mode Options, page 12-6](#)
- [Saving VLAN Configuration, page 12-6](#)
- [Default Ethernet VLAN Configuration, page 12-7](#)
- [Creating or Modifying an Ethernet VLAN, page 12-8](#)
- [Deleting a VLAN, page 12-9](#)
- [Assigning Static-Access Ports to a VLAN, page 12-10](#)

Token Ring VLANs

Although the switch does not support Token Ring connections, a remote device such as a Catalyst 5000 series switch with Token Ring connections could be managed from one of the supported switches. Switches running VTP Version 2 advertise information about these Token Ring VLANs:

- Token Ring TrBRF VLANs
- Token Ring TrCRF VLANs

For more information on configuring Token Ring VLANs, see the *Catalyst 5000 Series Software Configuration Guide*.

Normal-Range VLAN Configuration Guidelines

Follow these guidelines when creating and modifying normal-range VLANs in your network:

- The switch supports 255 VLANs in VTP client, server, and transparent modes.
- Normal-range VLANs are identified with a number between 1 and 1001. VLAN numbers 1002 through 1005 are reserved for Token Ring and FDDI VLANs.
- VLAN configuration for VLANs 1 to 1005 are always saved in the VLAN database. If the VTP mode is transparent, VTP and VLAN configuration are also saved in the switch running configuration file.
- The switch also supports VLAN IDs 1006 through 4094 in VTP transparent mode (VTP disabled). These are extended-range VLANs and configuration options are limited. Extended-range VLANs are not saved in the VLAN database. See the [“Configuring Extended-Range VLANs” section on page 12-11](#).
- Before you can create a VLAN, the switch must be in VTP server mode or VTP transparent mode. If the switch is a VTP server, you must define a VTP domain or VTP will not function.
- The switch does not support Token Ring or FDDI media. The switch does not forward FDDI, FDDI-Net, TrCRF, or TrBRF traffic, but it does propagate the VLAN configuration through VTP.
- The switch supports 128 spanning-tree instances. If a switch has more active VLANs than supported spanning-tree instances, spanning tree can be enabled on 128 VLANs and is disabled on the remaining VLANs. If you have already used all available spanning-tree instances on a switch, adding another VLAN anywhere in the VTP domain creates a VLAN on that switch that is not running spanning-tree. If you have the default allowed list on the trunk ports of that switch (which is to allow all VLANs), the new VLAN is carried on all trunk ports. Depending on the topology of the network, this could create a loop in the new VLAN that would not be broken, particularly if there

are several adjacent switches that all have run out of spanning-tree instances. You can prevent this possibility by setting allowed lists on the trunk ports of switches that have used up their allocation of spanning-tree instances.

If the number of VLANs on the switch exceeds the number of supported spanning-tree instances, we recommend that you configure the IEEE 802.1s Multiple STP (MSTP) on your switch to map multiple VLANs to a single spanning-tree instance. For more information about MSTP, see [Chapter 16, “Configuring MSTP.”](#)

VLAN Configuration Mode Options

You can configure normal-range VLANs (with VLAN IDs 1 to 1005) by using these two configuration modes:

- [VLAN Configuration in config-vlan Mode, page 12-6](#)

You access config-vlan mode by entering the **vlan** *vlan-id* global configuration command.

- [VLAN Configuration in VLAN Database Configuration Mode, page 12-6](#)

You access VLAN database configuration mode by entering the **vlan database** privileged EXEC command.

VLAN Configuration in config-vlan Mode

To access config-vlan mode, enter the **vlan** global configuration command with a VLAN ID. Enter a new VLAN ID to create a VLAN, or enter an existing VLAN ID to modify that VLAN. You can use the default VLAN configuration ([Table 12-2](#)) or enter multiple commands to configure the VLAN. For more information about commands available in this mode, see the **vlan** global configuration command description in the command reference for this release. When you have finished the configuration, you must exit config-vlan mode for the configuration to take effect. To display the VLAN configuration, enter the **show vlan** privileged EXEC command.

You must use this config-vlan mode when creating extended-range VLANs (VLAN IDs greater than 1005). See the [“Configuring Extended-Range VLANs”](#) section on page 12-11.

VLAN Configuration in VLAN Database Configuration Mode

To access VLAN database configuration mode, enter the **vlan database** privileged EXEC command. Then enter the **vlan** command with a new VLAN ID to create a VLAN, or enter an existing VLAN ID to modify the VLAN. You can use the default VLAN configuration ([Table 12-2](#)) or enter multiple commands to configure the VLAN. For more information about keywords available in this mode, see the **vlan** VLAN database configuration command description in the command reference for this release. When you have finished the configuration, you must enter **apply** or **exit** for the configuration to take effect. When you enter the **exit** command, it applies all commands and updates the VLAN database. VTP messages are sent to other switches in the VTP domain, and the privileged EXEC mode prompt appears.

Saving VLAN Configuration

The configurations of VLAN IDs 1 to 1005 are always saved in the VLAN database (vlan.dat file). If the VTP mode is transparent, they are also saved in the switch running configuration file. You can enter the **copy running-config startup-config** privileged EXEC command to save the configuration in the startup configuration file. To display the VLAN configuration, enter the **show vlan** privileged EXEC command.

When you save VLAN and VTP information (including extended-range VLAN configuration information) in the startup configuration file and reboot the switch, the switch configuration is selected as follows:

- If the VTP mode is transparent in the startup configuration, and the VLAN database and the VTP domain name from the VLAN database matches that in the startup configuration file, the VLAN database is ignored (cleared), and the VTP and VLAN configurations in the startup configuration file are used. The VLAN database revision number remains unchanged in the VLAN database.
- If the VTP mode or domain name in the startup configuration does not match the VLAN database, the domain name and VTP mode and configuration for the first 1005 VLANs use the VLAN database information.
- If VTP mode is server, the domain name and VLAN configuration for the first 1005 VLANs use the VLAN database information

Caution

If the VLAN database configuration is used at startup and the startup configuration file contains extended-range VLAN configuration, this information is lost when the system boots up.

Default Ethernet VLAN Configuration

Table 12-2 shows the default configuration for Ethernet VLANs.

Note

The switch supports Ethernet interfaces exclusively. Because FDDI and Token Ring VLANs are not locally supported, you only configure FDDI and Token Ring media-specific characteristics for VTP global advertisements to other switches.

Table 12-2 Ethernet VLAN Defaults and Ranges

Parameter	Default	Range
VLAN ID	1	1 to 4094. Note Extended-range VLANs (VLAN IDs 1006 to 4094) are not saved in the VLAN database.
VLAN name	<i>VLANxxxx</i> , where <i>xxxx</i> represents four numeric digits (including leading zeros) equal to the VLAN ID number	No range
IEEE 802.10 SAID	100001 (100000 plus the VLAN ID)	1 to 4294967294
MTU size	1500	1500 to 18190
Translational bridge 1	0	0 to 1005
Translational bridge 2	0	0 to 1005
VLAN state	active	active, suspend
Remote SPAN	disabled	enabled, disabled

Creating or Modifying an Ethernet VLAN

Each Ethernet VLAN in the VLAN database has a unique, 4-digit ID that can be a number from 1 to 1001. VLAN IDs 1002 to 1005 are reserved for Token Ring and FDDI VLANs. To create a normal-range VLAN to be added to the VLAN database, assign a number and name to the VLAN.



Note

When the switch is in VTP transparent mode, you can assign VLAN IDs greater than 1006, but they are not added to the VLAN database. See the “[Configuring Extended-Range VLANs](#)” section on page 12-11.

For the list of default parameters that are assigned when you add a VLAN, see the “[Configuring Normal-Range VLANs](#)” section on page 12-4.

Beginning in privileged EXEC mode, follow these steps to use config-vlan mode to create or modify an Ethernet VLAN:

	Command	Purpose
Step 1	configure terminal	Enter global configuration mode.
Step 2	vlan <i>vlan-id</i>	Enter a VLAN ID, and enter config-vlan mode. Enter a new VLAN ID to create a VLAN, or enter an existing VLAN ID to modify that VLAN. Note The available VLAN ID range for this command is 1 to 4094. For information about adding VLAN IDs greater than 1005 (extended-range VLANs), see the “ Configuring Extended-Range VLANs ” section on page 12-11.
Step 3	name <i>vlan-name</i>	(Optional) Enter a name for the VLAN. If no name is entered for the VLAN, the default is to append the <i>vlan-id</i> with leading zeros to the word VLAN. For example, VLAN0004 is a default VLAN name for VLAN 4.
Step 4	mtu <i>mtu-size</i>	(Optional) Change the MTU size (or other VLAN characteristic).
Step 5	remote-span	(Optional) Configure the VLAN as the RSPAN VLAN for a remote SPAN session. For more information on remote SPAN, see Chapter 23 , “ Configuring SPAN and RSPAN .”
Step 6	end	Return to privileged EXEC mode.
Step 7	show vlan { name <i>vlan-name</i> id <i>vlan-id</i> }	Verify your entries.
Step 8	copy running-config startup config	(Optional) If the switch is in VTP transparent mode, the VLAN configuration is saved in the running configuration file as well as in the VLAN database. This saves the configuration in the switch startup configuration file.

To return the VLAN name to the default settings, use the **no name**, **no mtu**, or **no remote-span** config-vlan commands.

This example shows how to use config-vlan mode to create Ethernet VLAN 20, name it *test20*, and add it to the VLAN database:

```
Switch# configure terminal
Switch(config)# vlan 20
Switch(config-vlan)# name test20
Switch(config-vlan)# end
```

You can also create or modify Ethernet VLANs by using the VLAN database configuration mode.

**Note**

VLAN database configuration mode does not support RSPAN VLAN configuration or extended-range VLANs.

Beginning in privileged EXEC mode, follow these steps to use VLAN database configuration mode to create or modify an Ethernet VLAN:

	Command	Purpose
Step 1	vlan database	Enter VLAN database configuration mode.
Step 2	vlan <i>vlan-id</i> name <i>vlan-name</i>	Add an Ethernet VLAN by assigning a number to it. The range is 1 to 1001. You can create or modify a range of consecutive VLANs by entering vlan <i>first-vlan-id</i> end <i>last-vlan-id</i> . Note When entering a VLAN ID in VLAN database configuration mode, do not enter leading zeros. If no name is entered for the VLAN, the default is to append the <i>vlan-id</i> with leading zeros to the word VLAN. For example, VLAN0004 is a default VLAN name for VLAN 4.
Step 3	vlan <i>vlan-id</i> mtu <i>mtu-size</i>	(Optional) To modify a VLAN, identify the VLAN and change a characteristic, such as the MTU size.
Step 4	exit	Update the VLAN database, propagate it throughout the administrative domain, and return to privileged EXEC mode.
Step 5	show vlan {name <i>vlan-name</i> id <i>vlan-id</i>}	Verify your entries.
Step 6	copy running-config startup config	(Optional) If the switch is in VTP transparent mode, the VLAN configuration is saved in the running configuration file as well as in the VLAN database. This saves the configuration in the switch startup configuration file.

To return the VLAN name to the default settings, use the **no vlan *vlan-id* name** or **no vlan *vlan-id* mtu** VLAN database configuration command.

This example shows how to use VLAN configuration mode to create Ethernet VLAN 20, name it *test20*, and add it to the VLAN database:

```
Switch# vlan database
Switch(vlan)# vlan 20 name test20
Switch(vlan)# exit
APPLY completed.
Exiting....
```

Deleting a VLAN

When you delete a VLAN from a switch that is in VTP server mode, the VLAN is removed from the VLAN database for all switches in the VTP domain. When you delete a VLAN from a switch that is in VTP transparent mode, the VLAN is deleted only on that specific switch.

You cannot delete the default VLANs for the different media types: Ethernet VLAN 1 and FDDI or Token Ring VLANs 1002 to 1005.

**Caution**

When you delete a VLAN, any ports assigned to that VLAN become inactive. They remain associated with the VLAN (and thus inactive) until you assign them to a new VLAN.

Beginning in privileged EXEC mode, follow these steps to delete a VLAN on the switch:

	Command	Purpose
Step 1	configure terminal	Enter global configuration mode.
Step 2	no vlan <i>vlan-id</i>	Remove the VLAN by entering the VLAN ID.
Step 3	end	Return to privileged EXEC mode.
Step 4	show vlan brief	Verify the VLAN removal.
Step 5	copy running-config startup config	(Optional) If the switch is in VTP transparent mode, the VLAN configuration is saved in the running configuration file as well as in the VLAN database. This saves the configuration in the switch startup configuration file.

To delete a VLAN by using VLAN database configuration mode, use the **vlan database** privileged EXEC command to enter VLAN database configuration mode and the **no vlan** *vlan-id* VLAN database configuration command.

Assigning Static-Access Ports to a VLAN

You can assign a static-access port to a VLAN without having VTP globally propagate VLAN configuration information by disabling VTP (VTP transparent mode).

If you are assigning a port on a cluster member switch to a VLAN, first use the **rcommand** privileged EXEC command to log in to the cluster member switch.

**Note**

If you assign an interface to a VLAN that does not exist, the new VLAN is created. (See the [“Creating or Modifying an Ethernet VLAN”](#) section on page 12-8.)

Beginning in privileged EXEC mode, follow these steps to assign a port to a VLAN in the VLAN database:

	Command	Purpose
Step 1	configure terminal	Enter global configuration mode
Step 2	interface <i>interface-id</i>	Enter the interface to be added to the VLAN.
Step 3	switchport mode access	Define the VLAN membership mode for the port (Layer 2 access port).
Step 4	switchport access vlan <i>vlan-id</i>	Assign the port to a VLAN. Valid VLAN IDs are 1 to 4094.
Step 5	end	Return to privileged EXEC mode.
Step 6	show running-config interface <i>interface-id</i>	Verify the VLAN membership mode of the interface.

	Command	Purpose
Step 7	<code>show interfaces interface-id switchport</code>	Verify your entries in the <i>Administrative Mode</i> and the <i>Access Mode VLAN</i> fields of the display.
Step 8	<code>copy running-config startup-config</code>	(Optional) Save your entries in the configuration file.

To return an interface to its default configuration, use the **default interface** *interface-id* interface configuration command.

This example shows how to configure a port as an access port in VLAN 2:

```
Switch# configure terminal
Enter configuration commands, one per line. End with CNTL/Z.
Switch(config)# interface gigabitethernet0/1
Switch(config-if)# switchport mode access
Switch(config-if)# switchport access vlan 2
Switch(config-if)# end
```

Configuring Extended-Range VLANs

When the switch is in VTP transparent mode (VTP disabled), you can create extended-range VLANs (in the range 1006 to 4094). Extended-range VLANs enable service providers to extend their infrastructure to a greater number of customers. The extended-range VLAN IDs are allowed for any switchport commands that allow VLAN IDs. You always use config-vlan mode (accessed by entering the **vlan** *vlan-id* global configuration command) to configure extended-range VLANs. The extended range is not supported in VLAN database configuration mode (accessed by entering the **vlan database** privileged EXEC command).

Extended-range VLAN configurations are not stored in the VLAN database, but because VTP mode is transparent, they are stored in the switch running configuration file, and you can save the configuration in the startup configuration file by using the **copy running-config startup-config** privileged EXEC command.



Note

Although the switch supports 4094 VLAN IDs, see the “Supported VLANs” section on page 12-2 for the actual number of VLANs supported.

These sections contain extended-range VLAN configuration information:

- [Default VLAN Configuration, page 12-11](#)
- [Extended-Range VLAN Configuration Guidelines, page 12-12](#)
- [Creating an Extended-Range VLAN, page 12-12](#)

Default VLAN Configuration

See [Table 12-2 on page 12-7](#) for the default configuration for Ethernet VLANs. You can change only the MTU size and the remote SPAN configuration state on extended-range VLANs; all other characteristics must remain at the default state.

Extended-Range VLAN Configuration Guidelines

Follow these guidelines when creating extended-range VLANs:

- To add an extended-range VLAN, you must use the **vlan** *vlan-id* global configuration command and access config-vlan mode. You cannot add extended-range VLANs in VLAN database configuration mode (accessed by entering the **vlan database** privileged EXEC command).
- VLAN IDs in the extended range are not saved in the VLAN database and are not recognized by VTP.
- You cannot include extended-range VLANs in the pruning eligible range.
- The switch must be in VTP transparent mode when you create extended-range VLANs. If VTP mode is server or client, an error message is generated, and the extended-range VLAN is rejected.
- You can set the VTP mode to transparent in global configuration mode or in VLAN database configuration mode. See the “[Disabling VTP \(VTP Transparent Mode\)](#)” section on page 13-12. You should save this configuration to the startup configuration so that the switch boots up in VTP transparent mode. Otherwise, you lose the extended-range VLAN configuration if the switch resets.
- STP is enabled by default on extended-range VLANs, but you can disable it by using the **no spanning-tree vlan** *vlan-id* global configuration command. When the maximum number of spanning-tree instances are on the switch, spanning tree is disabled on any newly created VLANs. If the number of VLANs on the switch exceeds the maximum number of spanning-tree instances, we recommend that you configure the IEEE 802.1s Multiple STP (MSTP) on your switch to map multiple VLANs to a single spanning-tree instance. For more information about MSTP, see [Chapter 16, “Configuring MSTP.”](#)
- Although the switch supports a total of 255 (normal-range and extended-range) VLANs, the number of configured features affects the use of the switch hardware. If you try to create an extended-range VLAN and there are not enough hardware resources available, an error message is generated, and the extended-range VLAN is rejected.

Creating an Extended-Range VLAN

You create an extended-range VLAN in global configuration mode by entering the **vlan** global configuration command with a VLAN ID from 1006 to 4094. This command accesses the config-vlan mode. The extended-range VLAN has the default Ethernet VLAN characteristics (see [Table 12-2](#)) and the MTU size, and RSPAN configuration are the only parameters you can change. See the description of the **vlan** global configuration command in the command reference for the default settings of all parameters. If you enter an extended-range VLAN ID when the switch is not in VTP transparent mode, an error message is generated when you exit from config-vlan mode, and the extended-range VLAN is not created.

Extended-range VLANs are not saved in the VLAN database; they are saved in the switch running configuration file. You can save the extended-range VLAN configuration in the switch startup configuration file by using the **copy running-config startup-config** privileged EXEC command.

Beginning in privileged EXEC mode, follow these steps to create an extended-range VLAN:

	Command	Purpose
Step 1	configure terminal	Enter global configuration mode.
Step 2	vtp mode transparent	Configure the switch for VTP transparent mode, disabling VTP.

	Command	Purpose
Step 3	<code>vlan <i>vlan-id</i></code>	Enter an extended-range VLAN ID and enter config-vlan mode. The range is 1006 to 4094.
Step 4	<code>mtu <i>mtu-size</i></code>	(Optional) Modify the VLAN by changing the MTU size. Note Although all VLAN commands appear in the CLI help in config-vlan mode, only the <code>mtu <i>mtu-size</i></code> , and <code>remote-span</code> commands are supported for extended-range VLANs.
Step 5	<code>remote-span</code>	(Optional) Configure the VLAN as the RSPAN VLAN. See the “Configuring a VLAN as an RSPAN VLAN” section on page 23-16.
Step 6	<code>end</code>	Return to privileged EXEC mode.
Step 7	<code>show vlan id <i>vlan-id</i></code>	Verify that the VLAN has been created.
Step 8	<code>copy running-config startup config</code>	Save your entries in the switch startup configuration file. To save extended-range VLAN configurations, you need to save the VTP transparent mode configuration and the extended-range VLAN configuration in the switch startup configuration file. Otherwise, if the switch resets, it will default to VTP server mode, and the extended-range VLAN IDs will not be saved.

To delete an extended-range VLAN, use the `no vlan vlan-id` global configuration command.

The procedure for assigning static-access ports to an extended-range VLAN is the same as for normal-range VLANs. See the [“Assigning Static-Access Ports to a VLAN”](#) section on page 12-10.

This example shows how to create a new extended-range VLAN with all default characteristics, enter config-vlan mode, and save the new VLAN in the switch startup configuration file:

```
Switch(config)# vtp mode transparent
Switch(config)# vlan 2000
Switch(config-vlan)# end
Switch# copy running-config startup config
```

Displaying VLANs

Use the `show vlan` privileged EXEC command to display a list of all VLANs on the switch, including extended-range VLANs. The display includes VLAN status, ports, and configuration information. To view normal-range VLANs in the VLAN database (1 to 1005), use the `show VLAN database` configuration command (accessed by entering the `vlan database` privileged EXEC command).

[Table 12-3](#) lists the commands for monitoring VLANs.

Table 12-3 VLAN Monitoring Commands

Command	Command Mode	Purpose
<code>show</code>	VLAN database configuration	Display status of VLANs in the VLAN database.
<code>show current [<i>vlan-id</i>]</code>	VLAN database configuration	Display status of all or the specified VLAN in the VLAN database.

Table 12-3 VLAN Monitoring Commands (continued)

Command	Command Mode	Purpose
<code>show interfaces [vlan <i>vlan-id</i>]</code>	Privileged EXEC	Display characteristics for all interfaces or for the specified VLAN configured on the switch.
<code>show vlan [id <i>vlan-id</i>]</code>	Privileged EXEC	Display parameters for all VLANs or the specified VLAN on the switch.

For more details about the show command options and explanations of output fields, see the command reference for this release.

Configuring VLAN Trunks

These sections contain this conceptual information:

- [Trunking Overview, page 12-14](#)
- [Default Layer 2 Ethernet Interface VLAN Configuration, page 12-16](#)
- [Configuring an Ethernet Interface as a Trunk Port, page 12-16](#)
- [Configuring Trunk Ports for Load Sharing, page 12-20](#)

Trunking Overview

A trunk is a point-to-point link between one or more Ethernet switch interfaces and another networking device such as a router or a switch. Ethernet trunks carry the traffic of multiple VLANs over a single link, and you can extend the VLANs across an entire network. The Catalyst 2960 switch supports IEEE 802.1Q encapsulation.

You can configure a trunk on a single Ethernet interface or on an EtherChannel bundle. For more information about EtherChannel, see [Chapter 31, “Configuring EtherChannels and Link-State Tracking.”](#)

Ethernet trunk interfaces support different trunking modes (see [Table 12-4](#)). You can set an interface as trunking or nontrunking or to negotiate trunking with the neighboring interface. To autonegotiate trunking, the interfaces must be in the same VTP domain.

Trunk negotiation is managed by the Dynamic Trunking Protocol (DTP), which is a Point-to-Point Protocol. However, some internetworking devices might forward DTP frames improperly, which could cause misconfigurations.

To avoid this, you should configure interfaces connected to devices that do not support DTP to not forward DTP frames, that is, to turn off DTP.

- If you do not intend to trunk across those links, use the **switchport mode access** interface configuration command to disable trunking.
- To enable trunking to a device that does not support DTP, use the **switchport mode trunk** and **switchport nonegotiate** interface configuration commands to cause the interface to become a trunk but to not generate DTP frames.

Table 12-4 Layer 2 Interface Modes

Mode	Function
switchport mode access	Puts the interface (access port) into permanent nontrunking mode and negotiates to convert the link into a nontrunk link. The interface becomes a nontrunk interface regardless of whether or not the neighboring interface is a trunk interface.
switchport mode dynamic auto	Makes the interface able to convert the link to a trunk link. The interface becomes a trunk interface if the neighboring interface is set to <i>trunk</i> or <i>desirable</i> mode. The default switchport mode for all Ethernet interfaces is dynamic auto .
switchport mode dynamic desirable	Makes the interface actively attempt to convert the link to a trunk link. The interface becomes a trunk interface if the neighboring interface is set to <i>trunk</i> , <i>desirable</i> , or <i>auto</i> mode.
switchport mode trunk	Puts the interface into permanent trunking mode and negotiates to convert the neighboring link into a trunk link. The interface becomes a trunk interface even if the neighboring interface is not a trunk interface.
switchport nonegotiate	Prevents the interface from generating DTP frames. You can use this command only when the interface switchport mode is access or trunk . You must manually configure the neighboring interface as a trunk interface to establish a trunk link.

IEEE 802.1Q Configuration Considerations

The IEEE 802.1Q trunks impose these limitations on the trunking strategy for a network:

- In a network of Cisco switches connected through IEEE 802.1Q trunks, the switches maintain one spanning-tree instance for each VLAN allowed on the trunks. Non-Cisco devices might support one spanning-tree instance for all VLANs.

When you connect a Cisco switch to a non-Cisco device through an IEEE 802.1Q trunk, the Cisco switch combines the spanning-tree instance of the VLAN of the trunk with the spanning-tree instance of the non-Cisco IEEE 802.1Q switch. However, spanning-tree information for each VLAN is maintained by Cisco switches separated by a cloud of non-Cisco IEEE 802.1Q switches. The non-Cisco IEEE 802.1Q cloud separating the Cisco switches is treated as a single trunk link between the switches.

- Make sure the native VLAN for an IEEE 802.1Q trunk is the same on both ends of the trunk link. If the native VLAN on one end of the trunk is different from the native VLAN on the other end, spanning-tree loops might result.
- Disabling spanning tree on the native VLAN of an IEEE 802.1Q trunk without disabling spanning tree on every VLAN in the network can potentially cause spanning-tree loops. We recommend that you leave spanning tree enabled on the native VLAN of an IEEE 802.1Q trunk or disable spanning tree on every VLAN in the network. Make sure your network is loop-free before you disable spanning tree.

Default Layer 2 Ethernet Interface VLAN Configuration

Table 12-5 shows the default Layer 2 Ethernet interface VLAN configuration.

Table 12-5 *Default Layer 2 Ethernet Interface VLAN Configuration*

Feature	Default Setting
Interface mode	switchport mode dynamic auto
Allowed VLAN range	VLANs 1 to 4094
VLAN range eligible for pruning	VLANs 2 to 1001
Default VLAN (for access ports)	VLAN 1
Native VLAN (for IEEE 802.1Q trunks)	VLAN 1

Configuring an Ethernet Interface as a Trunk Port

Because trunk ports send and receive VTP advertisements, to use VTP you must ensure that at least one trunk port is configured on the switch and that this trunk port is connected to the trunk port of a second switch. Otherwise, the switch cannot receive any VTP advertisements.

These sections contain this configuration information:

- [Interaction with Other Features, page 12-16](#)
- [Defining the Allowed VLANs on a Trunk, page 12-18](#)
- [Changing the Pruning-Eligible List, page 12-19](#)
- [Configuring the Native VLAN for Untagged Traffic, page 12-19](#)

Interaction with Other Features

Trunking interacts with other features in these ways:

- A trunk port cannot be a secure port.
- Trunk ports can be grouped into EtherChannel port groups, but all trunks in the group must have the same configuration. When a group is first created, all ports follow the parameters set for the first port to be added to the group. If you change the configuration of one of these parameters, the switch propagates the setting you entered to all ports in the group:
 - allowed-VLAN list.
 - STP port priority for each VLAN.
 - STP Port Fast setting.
 - trunk status: if one port in a port group ceases to be a trunk, all ports cease to be trunks.
- We recommend that you configure no more than 24 trunk ports in PVST mode and no more than 40 trunk ports in MST mode.

- If you try to enable IEEE 802.1x on a trunk port, an error message appears, and IEEE 802.1x is not enabled. If you try to change the mode of an IEEE 802.1x-enabled port to trunk, the port mode is not changed.
- A port in dynamic mode can negotiate with its neighbor to become a trunk port. If you try to enable IEEE 802.1x on a dynamic port, an error message appears, and IEEE 802.1x is not enabled. If you try to change the mode of an IEEE 802.1x-enabled port to dynamic, the port mode is not changed.

Configuring a Trunk Port

Beginning in privileged EXEC mode, follow these steps to configure a port as a trunk port:

	Command	Purpose
Step 1	configure terminal	Enter global configuration mode.
Step 2	interface <i>interface-id</i>	Specify the port to be configured for trunking, and enter interface configuration mode.
Step 3	switchport mode { dynamic { auto desirable } trunk }	Configure the interface as a Layer 2 trunk (required only if the interface is a Layer 2 access port or to specify the trunking mode). <ul style="list-style-type: none"> • dynamic auto—Set the interface to a trunk link if the neighboring interface is set to trunk or desirable mode. This is the default. • dynamic desirable—Set the interface to a trunk link if the neighboring interface is set to trunk, desirable, or auto mode. • trunk—Set the interface in permanent trunking mode and negotiate to convert the link to a trunk link even if the neighboring interface is not a trunk interface.
Step 4	switchport access vlan <i>vlan-id</i>	(Optional) Specify the default VLAN, which is used if the interface stops trunking.
Step 5	switchport trunk native vlan <i>vlan-id</i>	Specify the native VLAN for IEEE 802.1Q trunks.
Step 6	end	Return to privileged EXEC mode.
Step 7	show interfaces <i>interface-id</i> switchport	Display the switchport configuration of the interface in the <i>Administrative Mode</i> and the <i>Administrative Trunking Encapsulation</i> fields of the display.
Step 8	show interfaces <i>interface-id</i> trunk	Display the trunk configuration of the interface.
Step 9	copy running-config startup-config	(Optional) Save your entries in the configuration file.

To return an interface to its default configuration, use the **default interface** *interface-id* interface configuration command. To reset all trunking characteristics of a trunking interface to the defaults, use the **no switchport trunk** interface configuration command. To disable trunking, use the **switchport mode access** interface configuration command to configure the port as a static-access port.

This example shows how to configure a port as an IEEE 802.1Q trunk. The example assumes that the neighbor interface is configured to support IEEE 802.1Q trunking.

```
Switch# configure terminal
Enter configuration commands, one per line. End with CNTL/Z.
Switch(config)# interface gigabitethernet0/2
Switch(config-if)# switchport mode dynamic desirable
Switch(config-if)# end
```

Defining the Allowed VLANs on a Trunk

By default, a trunk port sends traffic to and receives traffic from all VLANs. All VLAN IDs, 1 to 4094, are allowed on each trunk. However, you can remove VLANs from the allowed list, preventing traffic from those VLANs from passing over the trunk. To restrict the traffic a trunk carries, use the **switchport trunk allowed vlan remove *vlan-list*** interface configuration command to remove specific VLANs from the allowed list.



Note

VLAN 1 is the default VLAN on all trunk ports in all Cisco switches, and it has previously been a requirement that VLAN 1 always be enabled on every trunk link. You can use the VLAN 1 minimization feature to disable VLAN 1 on any individual VLAN trunk link so that no user traffic (including spanning-tree advertisements) is sent or received on VLAN 1.

To reduce the risk of spanning-tree loops or storms, you can disable VLAN 1 on any individual VLAN trunk port by removing VLAN 1 from the allowed list. When you remove VLAN 1 from a trunk port, the interface continues to send and receive management traffic, for example, Cisco Discovery Protocol (CDP), Port Aggregation Protocol (PAgP), Link Aggregation Control Protocol (LACP), DTP, and VTP in VLAN 1.

If a trunk port with VLAN 1 disabled is converted to a nontrunk port, it is added to the access VLAN. If the access VLAN is set to 1, the port will be added to VLAN 1, regardless of the **switchport trunk allowed** setting. The same is true for any VLAN that has been disabled on the port.

A trunk port can become a member of a VLAN if the VLAN is enabled, if VTP knows of the VLAN, and if the VLAN is in the allowed list for the port. When VTP detects a newly enabled VLAN and the VLAN is in the allowed list for a trunk port, the trunk port automatically becomes a member of the enabled VLAN. When VTP detects a new VLAN and the VLAN is not in the allowed list for a trunk port, the trunk port does not become a member of the new VLAN.

Beginning in privileged EXEC mode, follow these steps to modify the allowed list of a trunk:

	Command	Purpose
Step 1	configure terminal	Enter global configuration mode.
Step 2	interface <i>interface-id</i>	Specify the port to be configured, and enter interface configuration mode.
Step 3	switchport mode trunk	Configure the interface as a VLAN trunk port.
Step 4	switchport trunk allowed vlan {add all except remove} <i>vlan-list</i>	<p>(Optional) Configure the list of VLANs allowed on the trunk.</p> <p>For explanations about using the add, all, except, and remove keywords, see the command reference for this release.</p> <p>The <i>vlan-list</i> parameter is either a single VLAN number from 1 to 4094 or a range of VLANs described by two VLAN numbers, the lower one first, separated by a hyphen. Do not enter any spaces between comma-separated VLAN parameters or in hyphen-specified ranges.</p> <p>All VLANs are allowed by default.</p>
Step 5	end	Return to privileged EXEC mode.
Step 6	show interfaces <i>interface-id</i> switchport	Verify your entries in the <i>Trunking VLANs Enabled</i> field of the display.
Step 7	copy running-config startup-config	(Optional) Save your entries in the configuration file.

To return to the default allowed VLAN list of all VLANs, use the **no switchport trunk allowed vlan** interface configuration command.

This example shows how to remove VLAN 2 from the allowed VLAN list on a port:

```
Switch(config)# interface gigabitethernet0/1
Switch(config-if)# switchport trunk allowed vlan remove 2
Switch(config-if)# end
```

Changing the Pruning-Eligible List

The pruning-eligible list applies only to trunk ports. Each trunk port has its own eligibility list. VTP pruning must be enabled for this procedure to take effect. The [“Enabling VTP Pruning” section on page 13-14](#) describes how to enable VTP pruning.

Beginning in privileged EXEC mode, follow these steps to remove VLANs from the pruning-eligible list on a trunk port:

	Command	Purpose
Step 1	configure terminal	Enter global configuration mode.
Step 2	interface <i>interface-id</i>	Select the trunk port for which VLANs should be pruned, and enter interface configuration mode.
Step 3	switchport trunk pruning vlan { add except none remove } <i>vlan-list</i> [<i>vlan</i> [, <i>vlan</i> [,]]	Configure the list of VLANs allowed to be pruned from the trunk. (See the “VTP Pruning” section on page 13-4). For explanations about using the add , except , none , and remove keywords, see the command reference for this release. Separate nonconsecutive VLAN IDs with a comma and no spaces; use a hyphen to designate a range of IDs. Valid IDs are 2 to 1001. Extended-range VLANs (VLAN IDs 1006 to 4094) cannot be pruned. VLANs that are pruning-ineligible receive flooded traffic. The default list of VLANs allowed to be pruned contains VLANs 2 to 1001.
Step 4	end	Return to privileged EXEC mode.
Step 5	show interfaces <i>interface-id</i> switchport	Verify your entries in the <i>Pruning VLANs Enabled</i> field of the display.
Step 6	copy running-config startup-config	(Optional) Save your entries in the configuration file.

To return to the default pruning-eligible list of all VLANs, use the **no switchport trunk pruning vlan** interface configuration command.

Configuring the Native VLAN for Untagged Traffic

A trunk port configured with IEEE 802.1Q tagging can receive both tagged and untagged traffic. By default, the switch forwards untagged traffic in the native VLAN configured for the port. The native VLAN is VLAN 1 by default.



Note

The native VLAN can be assigned any VLAN ID.

For information about IEEE 802.1Q configuration issues, see the [“IEEE 802.1Q Configuration Considerations” section on page 12-15](#).

Beginning in privileged EXEC mode, follow these steps to configure the native VLAN on an IEEE 802.1Q trunk:

	Command	Purpose
Step 1	configure terminal	Enter global configuration mode.
Step 2	interface <i>interface-id</i>	Define the interface that is configured as the IEEE 802.1Q trunk, and enter interface configuration mode.
Step 3	switchport trunk native vlan <i>vlan-id</i>	Configure the VLAN that is sending and receiving untagged traffic on the trunk port. For <i>vlan-id</i> , the range is 1 to 4094.
Step 4	end	Return to privileged EXEC mode.
Step 5	show interfaces <i>interface-id</i> switchport	Verify your entries in the <i>Trunking Native Mode VLAN</i> field.
Step 6	copy running-config startup-config	(Optional) Save your entries in the configuration file.

To return to the default native VLAN, VLAN 1, use the **no switchport trunk native vlan** interface configuration command.

If a packet has a VLAN ID that is the same as the outgoing port native VLAN ID, the packet is sent untagged; otherwise, the switch sends the packet with a tag.

Configuring Trunk Ports for Load Sharing

Load sharing divides the bandwidth supplied by parallel trunks connecting switches. To avoid loops, STP normally blocks all but one parallel link between switches. Using load sharing, you divide the traffic between the links according to which VLAN the traffic belongs.

You configure load sharing on trunk ports by using STP port priorities or STP path costs. For load sharing using STP port priorities, both load-sharing links must be connected to the same switch. For load sharing using STP path costs, each load-sharing link can be connected to the same switch or to two different switches. For more information about STP, see [Chapter 15, “Configuring STP.”](#)

Load Sharing Using STP Port Priorities

When two ports on the same switch form a loop, the switch uses the STP port priority to decide which port is enabled and which port is in a blocking state. You can set the priorities on a parallel trunk port so that the port carries all the traffic for a given VLAN. The trunk port with the higher priority (lower values) for a VLAN is forwarding traffic for that VLAN. The trunk port with the lower priority (higher values) for the same VLAN remains in a blocking state for that VLAN. One trunk port sends or receives all traffic for the VLAN.

[Figure 12-2](#) shows two trunks connecting supported switches. In this example, the switches are configured as follows:

- VLANs 8 through 10 are assigned a port priority of 16 on Trunk 1.
- VLANs 3 through 6 retain the default port priority of 128 on Trunk 1.

- VLANs 3 through 6 are assigned a port priority of 16 on Trunk 2.
- VLANs 8 through 10 retain the default port priority of 128 on Trunk 2.

In this way, Trunk 1 carries traffic for VLANs 8 through 10, and Trunk 2 carries traffic for VLANs 3 through 6. If the active trunk fails, the trunk with the lower priority takes over and carries the traffic for all of the VLANs. No duplication of traffic occurs over any trunk port.

Figure 12-2 Load Sharing by Using STP Port Priorities

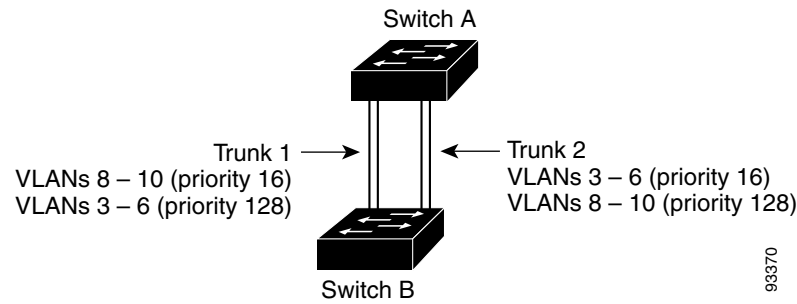

Beginning in privileged EXEC mode, follow these steps to configure the network shown in [Figure 12-2](#).

	Command	Purpose
Step 1	<code>configure terminal</code>	Enter global configuration mode on Switch A.
Step 2	<code>vtp domain domain-name</code>	Configure a VTP administrative domain. The domain name can be 1 to 32 characters.
Step 3	<code>vtp mode server</code>	Configure Switch A as the VTP server.
Step 4	<code>end</code>	Return to privileged EXEC mode.
Step 5	<code>show vtp status</code>	Verify the VTP configuration on both Switch A and Switch B. In the display, check the <i>VTP Operating Mode</i> and the <i>VTP Domain Name</i> fields.
Step 6	<code>show vlan</code>	Verify that the VLANs exist in the database on Switch A.
Step 7	<code>configure terminal</code>	Enter global configuration mode.
Step 8	<code>interface gigabitethernet 0/1</code>	Define the interface to be configured as a trunk, and enter interface configuration mode.
Step 9	<code>switchport mode trunk</code>	Configure the port as a trunk port.
Step 10	<code>end</code>	Return to privileged EXEC mode.
Step 11	<code>show interfaces gigabitethernet 0/1 switchport</code>	Verify the VLAN configuration.
Step 12		Repeat Steps 7 through 10 on Switch A for a second port in the switch.
Step 13		Repeat Steps 7 through 10 on Switch B to configure the trunk ports that connect to the trunk ports configured on Switch A.
Step 14	<code>show vlan</code>	When the trunk links come up, VTP passes the VTP and VLAN information to Switch B. Verify that Switch B has learned the VLAN configuration.
Step 15	<code>configure terminal</code>	Enter global configuration mode on Switch A.

	Command	Purpose
Step 16	<code>interface gigabitethernet 0/1</code>	Define the interface to set the STP port priority, and enter interface configuration mode.
Step 17	<code>spanning-tree vlan 8-10 port-priority 16</code>	Assign the port priority of 16 for VLANs 8 through 10.
Step 18	<code>exit</code>	Return to global configuration mode.
Step 19	<code>interface gigabitethernet0/2</code>	Define the interface to set the STP port priority, and enter interface configuration mode.
Step 20	<code>spanning-tree vlan 3-6 port-priority 16</code>	Assign the port priority of 16 for VLANs 3 through 6.
Step 21	<code>end</code>	Return to privileged EXEC mode.
Step 22	<code>show running-config</code>	Verify your entries.
Step 23	<code>copy running-config startup-config</code>	(Optional) Save your entries in the configuration file.

Load Sharing Using STP Path Cost

You can configure parallel trunks to share VLAN traffic by setting different path costs on a trunk and associating the path costs with different sets of VLANs, blocking different ports for different VLANs. The VLANs keep the traffic separate and maintain redundancy in the event of a lost link.

In [Figure 12-3](#), Trunk ports 1 and 2 are configured as 100BASE-T ports. These VLAN path costs are assigned:

- VLANs 2 through 4 are assigned a path cost of 30 on Trunk port 1.
- VLANs 8 through 10 retain the default 100BASE-T path cost on Trunk port 1 of 19.
- VLANs 8 through 10 are assigned a path cost of 30 on Trunk port 2.
- VLANs 2 through 4 retain the default 100BASE-T path cost on Trunk port 2 of 19.

Figure 12-3 Load-Sharing Trunks with Traffic Distributed by Path Cost

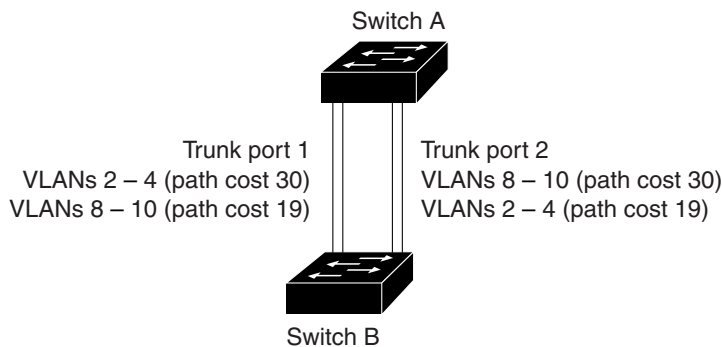

Beginning in privileged EXEC mode, follow these steps to configure the network shown in [Figure 12-3](#):

	Command	Purpose
Step 1	<code>configure terminal</code>	Enter global configuration mode on Switch A.
Step 2	<code>interface gigabitethernet0/1</code>	Define the interface to be configured as a trunk, and enter interface configuration mode.
Step 3	<code>switchport mode trunk</code>	Configure the port as a trunk port.

	Command	Purpose
Step 4	<code>exit</code>	Return to global configuration mode.
Step 5		Repeat Steps 2 through 4 on a second interface in Switch A.
Step 6	<code>end</code>	Return to privileged EXEC mode.
Step 7	<code>show running-config</code>	Verify your entries. In the display, make sure that the interfaces are configured as trunk ports.
Step 8	<code>show vlan</code>	When the trunk links come up, Switch A receives the VTP information from the other switches. Verify that Switch A has learned the VLAN configuration.
Step 9	<code>configure terminal</code>	Enter global configuration mode.
Step 10	<code>interface gigabitethernet0/1</code>	Define the interface on which to set the STP cost, and enter interface configuration mode.
Step 11	<code>spanning-tree vlan 2-4 cost 30</code>	Set the spanning-tree path cost to 30 for VLANs 2 through 4.
Step 12	<code>end</code>	Return to global configuration mode.
Step 13		Repeat Steps 9 through 12 on the other configured trunk interface on Switch A, and set the spanning-tree path cost to 30 for VLANs 8, 9, and 10.
Step 14	<code>exit</code>	Return to privileged EXEC mode.
Step 15	<code>show running-config</code>	Verify your entries. In the display, verify that the path costs are set correctly for both trunk interfaces.
Step 16	<code>copy running-config startup-config</code>	(Optional) Save your entries in the configuration file.

Configuring VMPS

The VLAN Query Protocol (VQP) is used to support dynamic-access ports, which are not permanently assigned to a VLAN, but give VLAN assignments based on the MAC source addresses seen on the port. Each time an unknown MAC address is seen, the switch sends a VQP query to a remote VMPS; the query includes the newly seen MAC address and the port on which it was seen. The VMPS responds with a VLAN assignment for the port. The switch cannot be a VMPS server but can act as a client to the VMPS and communicate with it through VQP.

These sections contain this information:

- [“Understanding VMPS” section on page 12-24](#)
- [“Default VMPS Client Configuration” section on page 12-25](#)
- [“VMPS Configuration Guidelines” section on page 12-25](#)
- [“Configuring the VMPS Client” section on page 12-25](#)
- [“Monitoring the VMPS” section on page 12-28](#)
- [“Troubleshooting Dynamic-Access Port VLAN Membership” section on page 12-29](#)
- [“VMPS Configuration Example” section on page 12-29](#)

Understanding VMPS

Each time the client switch receives the MAC address of a new host, it sends a VQP query to the VMPS. When the VMPS receives this query, it searches its database for a MAC-address-to-VLAN mapping. The server response is based on this mapping and whether or not the server is in open or secure mode. In secure mode, the server shuts down the port when an illegal host is detected. In open mode, the server simply denies the host access to the port.

If the port is currently *unassigned* (that is, it does not yet have a VLAN assignment), the VMPS provides one of these responses:

- If the host is allowed on the port, the VMPS sends the client a *vlan-assignment* response containing the assigned VLAN name and allowing access to the host.
- If the host is not allowed on the port and the VMPS is in open mode, the VMPS sends an *access-denied* response.
- If the VLAN is not allowed on the port and the VMPS is in secure mode, the VMPS sends a *port-shutdown* response.

If the port already has a VLAN assignment, the VMPS provides one of these responses:

- If the VLAN in the database matches the current VLAN on the port, the VMPS sends an *success* response, allowing access to the host.
- If the VLAN in the database does not match the current VLAN on the port and active hosts exist on the port, the VMPS sends an *access-denied* or a *port-shutdown* response, depending on the secure mode of the VMPS.

If the switch receives an *access-denied* response from the VMPS, it continues to block traffic to and from the host MAC address. The switch continues to monitor the packets directed to the port and sends a query to the VMPS when it identifies a new host address. If the switch receives a *port-shutdown* response from the VMPS, it disables the port. The port must be manually re-enabled by using Network Assistant, the CLI, or SNMP.

Dynamic-Access Port VLAN Membership

A dynamic-access port can belong to only one VLAN with an ID from 1 to 4094. When the link comes up, the switch does not forward traffic to or from this port until the VMPS provides the VLAN assignment. The VMPS receives the source MAC address from the first packet of a new host connected to the dynamic-access port and attempts to match the MAC address to a VLAN in the VMPS database.

If there is a match, the VMPS sends the VLAN number for that port. If the client switch was not previously configured, it uses the domain name from the first VTP packet it receives on its trunk port from the VMPS. If the client switch was previously configured, it includes its domain name in the query packet to the VMPS to obtain its VLAN number. The VMPS verifies that the domain name in the packet matches its own domain name before accepting the request and responds to the client with the assigned VLAN number for the client. If there is no match, the VMPS either denies the request or shuts down the port (depending on the VMPS secure mode setting).

Multiple hosts (MAC addresses) can be active on a dynamic-access port if they are all in the same VLAN; however, the VMPS shuts down a dynamic-access port if more than 20 hosts are active on the port.

If the link goes down on a dynamic-access port, the port returns to an isolated state and does not belong to a VLAN. Any hosts that come online through the port are checked again through the VQP with the VMPS before the port is assigned to a VLAN.

Dynamic-access ports can be used for direct host connections, or they can connect to a network. A maximum of 20 MAC addresses are allowed per port on the switch. A dynamic-access port can belong to only one VLAN at a time, but the VLAN can change over time, depending on the MAC addresses seen.

Default VMPS Client Configuration

Table 12-6 shows the default VMPS and dynamic-access port configuration on client switches.

Table 12-6 Default VMPS Client and Dynamic-Access Port Configuration

Feature	Default Setting
VMPS domain server	None
VMPS reconfirm interval	60 minutes
VMPS server retry count	3
Dynamic-access ports	None configured

VMPS Configuration Guidelines

These guidelines and restrictions apply to dynamic-access port VLAN membership:

- You should configure the VMPS before you configure ports as dynamic-access ports.
- When you configure a port as a dynamic-access port, the spanning-tree Port Fast feature is automatically enabled for that port. The Port Fast mode accelerates the process of bringing the port into the forwarding state.
- IEEE 802.1x ports cannot be configured as dynamic-access ports. If you try to enable IEEE 802.1x on a dynamic-access (VQP) port, an error message appears, and IEEE 802.1x is not enabled. If you try to change an IEEE 802.1x-enabled port to dynamic VLAN assignment, an error message appears, and the VLAN configuration is not changed.
- Trunk ports cannot be dynamic-access ports, but you can enter the **switchport access vlan dynamic** interface configuration command for a trunk port. In this case, the switch retains the setting and applies it if the port is later configured as an access port.

You must turn off trunking on the port before the dynamic-access setting takes effect.

- Dynamic-access ports cannot be monitor ports.
- Secure ports cannot be dynamic-access ports. You must disable port security on a port before it becomes dynamic.
- Dynamic-access ports cannot be members of an EtherChannel group.
- Port channels cannot be configured as dynamic-access ports.
- The VTP management domain of the VMPS client and the VMPS server must be the same.
- The VLAN configured on the VMPS server should not be a voice VLAN.

Configuring the VMPS Client

You configure dynamic VLANs by using the VMPS (server). The switch can be a VMPS client; it cannot be a VMPS server.

Entering the IP Address of the VMPS

You must first enter the IP address of the server to configure the switch as a client.

Note

If the VMPS is being defined for a cluster of switches, enter the address on the command switch.

Beginning in privileged EXEC mode, follow these steps to enter the IP address of the VMPS:

	Command	Purpose
Step 1	<code>configure terminal</code>	Enter global configuration mode.
Step 2	<code>vmps server ipaddress primary</code>	Enter the IP address of the switch acting as the primary VMPS server.
Step 3	<code>vmps server ipaddress</code>	(Optional) Enter the IP address of the switch acting as a secondary VMPS server. You can enter up to three secondary server addresses.
Step 4	<code>end</code>	Return to privileged EXEC mode.
Step 5	<code>show vmps</code>	Verify your entries in the <i>VMPS Domain Server</i> field of the display.
Step 6	<code>copy running-config startup-config</code>	(Optional) Save your entries in the configuration file.

Note

You must have IP connectivity to the VMPS for dynamic-access ports to work. You can test for IP connectivity by pinging the IP address of the VMPS and verifying that you get a response.

Configuring Dynamic-Access Ports on VMPS Clients

If you are configuring a port on a cluster member switch as a dynamic-access port, first use the **rcommand** privileged EXEC command to log in to the cluster member switch.

Caution

Dynamic-access port VLAN membership is for end stations or hubs connected to end stations. Connecting dynamic-access ports to other switches can cause a loss of connectivity.

Beginning in privileged EXEC mode, follow these steps to configure a dynamic-access port on a VMPS client switch:

	Command	Purpose
Step 1	<code>configure terminal</code>	Enter global configuration mode.
Step 2	<code>interface interface-id</code>	Specify the switch port that is connected to the end station, and enter interface configuration mode.
Step 3	<code>switchport mode access</code>	Set the port to access mode.
Step 4	<code>switchport access vlan dynamic</code>	Configure the port as eligible for dynamic VLAN membership. The dynamic-access port must be connected to an end station.
Step 5	<code>end</code>	Return to privileged EXEC mode.

	Command	Purpose
Step 6	show interfaces <i>interface-id</i> switchport	Verify your entries in the <i>Operational Mode</i> field of the display.
Step 7	copy running-config startup-config	(Optional) Save your entries in the configuration file.

To return an interface to its default configuration, use the **default interface** *interface-id* interface configuration command. To return an interface to its default switchport mode (dynamic auto), use the **no switchport mode** interface configuration command. To reset the access mode to the default VLAN for the switch, use the **no switchport access vlan** interface configuration command.

Reconfirming VLAN Memberships

Beginning in privileged EXEC mode, follow these steps to confirm the dynamic-access port VLAN membership assignments that the switch has received from the VMPS:

	Command	Purpose
Step 1	vmpls reconfirm	Reconfirm dynamic-access port VLAN membership.
Step 2	show vmpls	Verify the dynamic VLAN reconfirmation status.

Changing the Reconfirmation Interval

VMPS clients periodically reconfirm the VLAN membership information received from the VMPS. You can set the number of minutes after which reconfirmation occurs.

If you are configuring a member switch in a cluster, this parameter must be equal to or greater than the reconfirmation setting on the command switch. You must also first use the **rcommand** privileged EXEC command to log in to the member switch.

Beginning in privileged EXEC mode, follow these steps to change the reconfirmation interval:

	Command	Purpose
Step 1	configure terminal	Enter global configuration mode.
Step 2	vmpls reconfirm <i>minutes</i>	Enter the number of minutes between reconfirmations of the dynamic VLAN membership. The range is 1 to 120. The default is 60 minutes.
Step 3	end	Return to privileged EXEC mode.
Step 4	show vmpls	Verify the dynamic VLAN reconfirmation status in the <i>Reconfirm Interval</i> field of the display.
Step 5	copy running-config startup-config	(Optional) Save your entries in the configuration file.

To return the switch to its default setting, use the **no vmpls reconfirm** global configuration command.

Changing the Retry Count

Beginning in privileged EXEC mode, follow these steps to change the number of times that the switch attempts to contact the VMPS before querying the next server:

	Command	Purpose
Step 1	configure terminal	Enter global configuration mode.
Step 2	vmpls retry count	Change the retry count. The retry range is 1 to 10; the default is 3.
Step 3	end	Return to privileged EXEC mode.
Step 4	show vmpls	Verify your entry in the <i>Server Retry Count</i> field of the display.
Step 5	copy running-config startup-config	(Optional) Save your entries in the configuration file.

To return the switch to its default setting, use the **no vmpls retry** global configuration command.

Monitoring the VMPS

You can display information about the VMPS by using the **show vmpls** privileged EXEC command. The switch displays this information about the VMPS:

- **VMPS VQP Version**—the version of VQP used to communicate with the VMPS. The switch queries the VMPS that is using VQP Version 1.
- **Reconfirm Interval**—the number of minutes the switch waits before reconfirming the VLAN-to-MAC-address assignments.
- **Server Retry Count**—the number of times VQP resends a query to the VMPS. If no response is received after this many tries, the switch starts to query the secondary VMPS.
- **VMPS domain server**—the IP address of the configured VLAN membership policy servers. The switch sends queries to the one marked *current*. The one marked *primary* is the primary server.
- **VMPS Action**—the result of the most recent reconfirmation attempt. A reconfirmation attempt can occur automatically when the reconfirmation interval expires, or you can force it by entering the **vmpls reconfirm** privileged EXEC command or its Network Assistant or SNMP equivalent.

This is an example of output for the **show vmps** privileged EXEC command:

```
Switch# show vmps
VQP Client Status:
-----
VMPS VQP Version: 1
Reconfirm Interval: 60 min
Server Retry Count: 3
VMPS domain server: 172.20.128.86 (primary, current)
                   172.20.128.87

Reconfirmation status
-----
VMPS Action:          other
```

Troubleshooting Dynamic-Access Port VLAN Membership

The VMPS shuts down a dynamic-access port under these conditions:

- The VMPS is in secure mode, and it does not allow the host to connect to the port. The VMPS shuts down the port to prevent the host from connecting to the network.
- More than 20 active hosts reside on a dynamic-access port.

To re-enable a disabled dynamic-access port, enter the **shutdown** interface configuration command followed by the **no shutdown** interface configuration command.

VMPS Configuration Example

Figure 12-4 shows a network with a VMPS server switch and VMPS client switches with dynamic-access ports. In this example, these assumptions apply:

- The VMPS server and the VMPS client are separate switches.
- The Catalyst 6500 series Switch A is the primary VMPS server.
- The Catalyst 6500 series Switch C and Switch J are secondary VMPS servers.
- End stations are connected to the clients, Switch B and Switch I.
- The database configuration file is stored on the TFTP server with the IP address 172.20.22.7.

Figure 12-4 Dynamic Port VLAN Membership Configuration

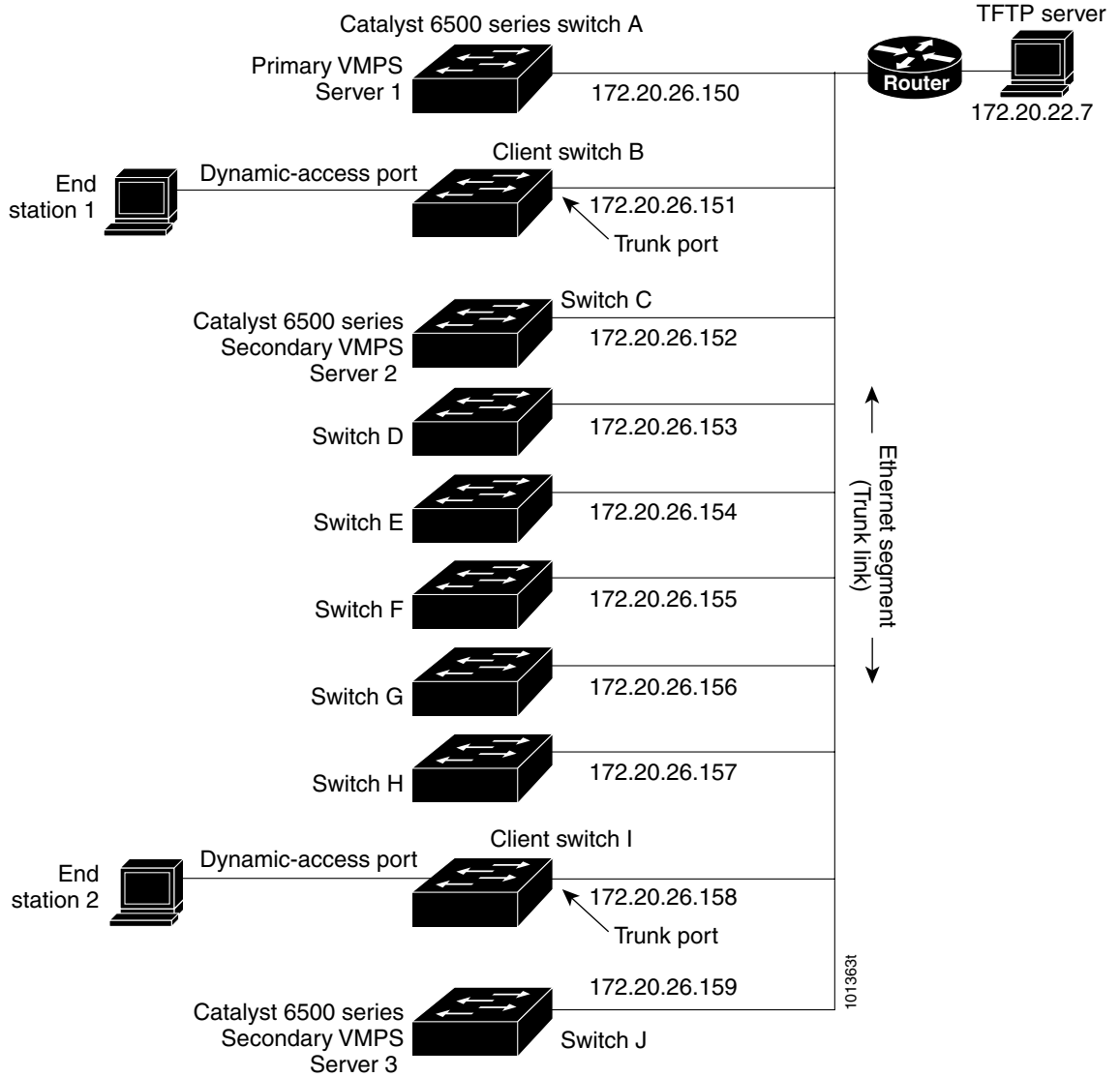

101363T



CHAPTER 13

Configuring VTP

This chapter describes how to use the VLAN Trunking Protocol (VTP) and the VLAN database for managing VLANs with the Catalyst 2960 switch.



Note

For complete syntax and usage information for the commands used in this chapter, see the command reference for this release.

The chapter consists of these sections:

- [Understanding VTP, page 13-1](#)
- [Configuring VTP, page 13-6](#)
- [Monitoring VTP, page 13-16](#)

Understanding VTP

VTP is a Layer 2 messaging protocol that maintains VLAN configuration consistency by managing the addition, deletion, and renaming of VLANs on a network-wide basis. VTP minimizes misconfigurations and configuration inconsistencies that can cause several problems, such as duplicate VLAN names, incorrect VLAN-type specifications, and security violations.

Before you create VLANs, you must decide whether to use VTP in your network. Using VTP, you can make configuration changes centrally on one or more switches and have those changes automatically communicated to all the other switches in the network. Without VTP, you cannot send information about VLANs to other switches.

VTP is designed to work in an environment where updates are made on a single switch and are sent through VTP to other switches in the domain. It does not work well in a situation where multiple updates to the VLAN database occur simultaneously on switches in the same domain, which would result in an inconsistency in the VLAN database.

The switch supports 255 VLANs, but the number of configured features affects the usage of the switch hardware. If the switch is notified by VTP of a new VLAN and the switch is already using the maximum available hardware resources, it sends a message that there are not enough hardware resources available and shuts down the VLAN. The output of the **show vlan** user EXEC command shows the VLAN in a suspended state.

VTP only learns about normal-range VLANs (VLAN IDs 1 to 1005). Extended-range VLANs (VLAN IDs greater than 1005) are not supported by VTP or stored in the VTP VLAN database.

These sections contain this conceptual information:

- [The VTP Domain, page 13-2](#)
- [VTP Modes, page 13-3](#)
- [VTP Advertisements, page 13-3](#)
- [VTP Version 2, page 13-4](#)
- [VTP Pruning, page 13-4](#)

The VTP Domain

A VTP domain (also called a VLAN management domain) consists of one switch or several interconnected switches under the same administrative responsibility sharing the same VTP domain name. A switch can be in only one VTP domain. You make global VLAN configuration changes for the domain.

By default, the switch is in the VTP no-management-domain state until it receives an advertisement for a domain over a trunk link (a link that carries the traffic of multiple VLANs) or until you configure a domain name. Until the management domain name is specified or learned, you cannot create or modify VLANs on a VTP server, and VLAN information is not propagated over the network.

If the switch receives a VTP advertisement over a trunk link, it inherits the management domain name and the VTP configuration revision number. The switch then ignores advertisements with a different domain name or an earlier configuration revision number.



Caution

Before adding a VTP client switch to a VTP domain, always verify that its VTP configuration revision number is *lower* than the configuration revision number of the other switches in the VTP domain. Switches in a VTP domain always use the VLAN configuration of the switch with the highest VTP configuration revision number. If you add a switch that has a revision number higher than the revision number in the VTP domain, it can erase all VLAN information from the VTP server and VTP domain. See the [“Adding a VTP Client Switch to a VTP Domain”](#) section on page 13-14 for the procedure for verifying and resetting the VTP configuration revision number.

When you make a change to the VLAN configuration on a VTP server, the change is propagated to all switches in the VTP domain. VTP advertisements are sent over all IEEE trunk connections, including IEEE 802.1Q. VTP dynamically maps VLANs with unique names and internal index associates across multiple LAN types. Mapping eliminates excessive device administration required from network administrators.

If you configure a switch for VTP transparent mode, you can create and modify VLANs, but the changes are not sent to other switches in the domain, and they affect only the individual switch. However, configuration changes made when the switch is in this mode are saved in the switch running configuration and can be saved to the switch startup configuration file.

For domain name and password configuration guidelines, see the [“VTP Configuration Guidelines”](#) section on page 13-8.

VTP Modes

You can configure a supported switch to be in one of the VTP modes listed in [Table 13-1](#).

Table 13-1 VTP Modes

VTP Mode	Description
VTP server	<p>In VTP server mode, you can create, modify, and delete VLANs, and specify other configuration parameters (such as the VTP version) for the entire VTP domain. VTP servers advertise their VLAN configurations to other switches in the same VTP domain and synchronize their VLAN configurations with other switches based on advertisements received over trunk links.</p> <p>In VTP server mode, VLAN configurations are saved in NVRAM. VTP server is the default mode.</p>
VTP client	<p>A VTP client behaves like a VTP server and transmits and receives VTP updates on its trunks, but you cannot create, change, or delete VLANs on a VTP client. VLANs are configured on another switch in the domain that is in server mode.</p> <p>In VTP client mode, VLAN configurations are not saved in NVRAM.</p>
VTP transparent	<p>VTP transparent switches do not participate in VTP. A VTP transparent switch does not advertise its VLAN configuration and does not synchronize its VLAN configuration based on received advertisements. However, in VTP Version 2, transparent switches do forward VTP advertisements that they receive from other switches through their trunk interfaces. You can create, modify, and delete VLANs on a switch in VTP transparent mode.</p> <p>The switch must be in VTP transparent mode when you create extended-range VLANs. See the “Configuring Extended-Range VLANs” section on page 12-11.</p> <p>When the switch is in VTP transparent mode, the VTP and VLAN configurations are saved in NVRAM, but they are not advertised to other switches. In this mode, VTP mode and domain name are saved in the switch running configuration, and you can save this information in the switch startup configuration file by using the copy running-config startup-config privileged EXEC command.</p>

VTP Advertisements

Each switch in the VTP domain sends periodic global configuration advertisements from each trunk port to a reserved multicast address. Neighboring switches receive these advertisements and update their VTP and VLAN configurations as necessary.



Note

Because trunk ports send and receive VTP advertisements, you must ensure that at least one trunk port is configured on the switch and that this trunk port is connected to the trunk port of another switch. Otherwise, the switch cannot receive any VTP advertisements. For more information on trunk ports, see the [“Configuring VLAN Trunks”](#) section on page 12-14.

VTP advertisements distribute this global domain information:

- VTP domain name
- VTP configuration revision number
- Update identity and update timestamp

- MD5 digest VLAN configuration, including maximum transmission unit (MTU) size for each VLAN.
- Frame format

VTP advertisements distribute this VLAN information for each configured VLAN:

- VLAN IDs (IEEE 802.1Q)
- VLAN name
- VLAN type
- VLAN state
- Additional VLAN configuration information specific to the VLAN type

VTP Version 2

If you use VTP in your network, you must decide whether to use Version 1 or Version 2. By default, VTP operates in Version 1.

VTP Version 2 supports these features that are not supported in Version 1:

- Token Ring support—VTP Version 2 supports Token Ring Bridge Relay Function (TrBRF) and Token Ring Concentrator Relay Function (TrCRF) VLANs. For more information about Token Ring VLANs, see the [“Configuring Normal-Range VLANs” section on page 12-4](#).
- Unrecognized Type-Length-Value (TLV) support—A VTP server or client propagates configuration changes to its other trunks, even for TLVs it is not able to parse. The unrecognized TLV is saved in NVRAM when the switch is operating in VTP server mode.
- Version-Dependent Transparent Mode—In VTP Version 1, a VTP transparent switch inspects VTP messages for the domain name and version and forwards a message only if the version and domain name match. Because VTP Version 2 supports only one domain, it forwards VTP messages in transparent mode without inspecting the version and domain name.
- Consistency Checks—In VTP Version 2, VLAN consistency checks (such as VLAN names and values) are performed only when you enter new information through the CLI or SNMP. Consistency checks are not performed when new information is obtained from a VTP message or when information is read from NVRAM. If the MD5 digest on a received VTP message is correct, its information is accepted.

VTP Pruning

VTP pruning increases network available bandwidth by restricting flooded traffic to those trunk links that the traffic must use to reach the destination devices. Without VTP pruning, a switch floods broadcast, multicast, and unknown unicast traffic across all trunk links within a VTP domain even though receiving switches might discard them. VTP pruning is disabled by default.

VTP pruning blocks unneeded flooded traffic to VLANs on trunk ports that are included in the pruning-eligible list. Only VLANs included in the pruning-eligible list can be pruned. By default, VLANs 2 through 1001 are pruning-eligible switch trunk ports. If the VLANs are configured as pruning-ineligible, the flooding continues. VTP pruning is supported with VTP Version 1 and Version 2.

Figure 13-1 shows a switched network without VTP pruning enabled. Port 1 on Switch A and Port 2 on Switch D are assigned to the Red VLAN. If a broadcast is sent from the host connected to Switch A, Switch A floods the broadcast and every switch in the network receives it, even though Switches C, E, and F have no ports in the Red VLAN.

Figure 13-1 Flooding Traffic without VTP Pruning

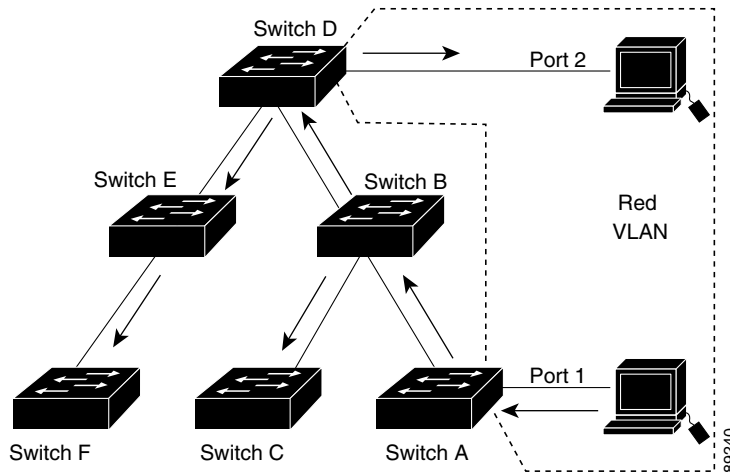
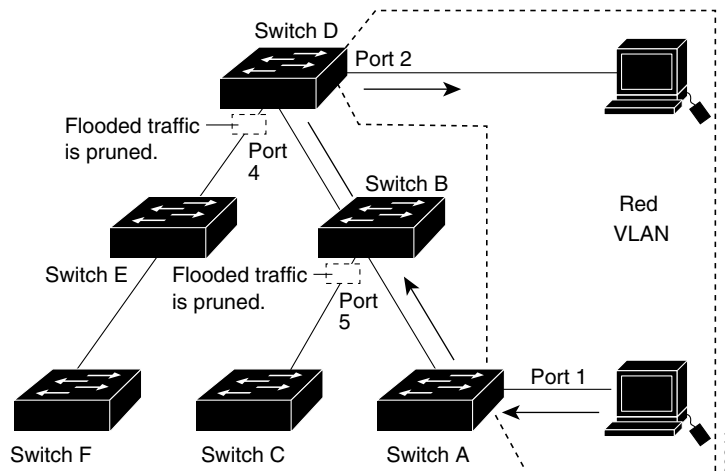

Figure 13-2 shows a switched network with VTP pruning enabled. The broadcast traffic from Switch A is not forwarded to Switches C, E, and F because traffic for the Red VLAN has been pruned on the links shown (Port 5 on Switch B and Port 4 on Switch D).

Figure 13-2 Optimized Flooded Traffic with VTP Pruning



Enabling VTP pruning on a VTP server enables pruning for the entire management domain. Making VLANs pruning-eligible or pruning-ineligible affects pruning eligibility for those VLANs on that trunk only (not on all switches in the VTP domain).

See the “[Enabling VTP Pruning](#)” section on page 13-14. VTP pruning takes effect several seconds after you enable it. VTP pruning does not prune traffic from VLANs that are pruning-ineligible. VLAN 1 and VLANs 1002 to 1005 are always pruning-ineligible; traffic from these VLANs cannot be pruned. Extended-range VLANs (VLAN IDs higher than 1005) are also pruning-ineligible.

VTP pruning is not designed to function in VTP transparent mode. If one or more switches in the network are in VTP transparent mode, you should do one of these:

- Turn off VTP pruning in the entire network.
- Turn off VTP pruning by making all VLANs on the trunk of the switch upstream to the VTP transparent switch pruning ineligible.

To configure VTP pruning on an interface, use the **switchport trunk pruning vlan** interface configuration command (see the “[Changing the Pruning-Eligible List](#)” section on page 12-19). VTP pruning operates when an interface is trunking. You can set VLAN pruning-eligibility, whether or not VTP pruning is enabled for the VTP domain, whether or not any given VLAN exists, and whether or not the interface is currently trunking.

Configuring VTP

These sections contain this configuration information:

- [Default VTP Configuration](#), page 13-6
- [VTP Configuration Options](#), page 13-7
- [VTP Configuration Guidelines](#), page 13-8
- [Configuring a VTP Server](#), page 13-9
- [Configuring a VTP Client](#), page 13-11
- [Disabling VTP \(VTP Transparent Mode\)](#), page 13-12
- [Enabling VTP Version 2](#), page 13-13
- [Enabling VTP Pruning](#), page 13-14
- [Adding a VTP Client Switch to a VTP Domain](#), page 13-14

Default VTP Configuration

[Table 13-2](#) shows the default VTP configuration.

Table 13-2 *Default VTP Configuration*

Feature	Default Setting
VTP domain name	Null.
VTP mode	Server.
VTP version	Version 1 (Version 2 is disabled).
VTP password	None.
VTP pruning	Disabled.

VTP Configuration Options

You can configure VTP by using these configuration modes.

- [VTP Configuration in Global Configuration Mode, page 13-7](#)
- [VTP Configuration in VLAN Database Configuration Mode, page 13-7](#)

You access VLAN database configuration mode by entering the **vlan database** privileged EXEC command.

For detailed information about **vtp** commands, see the command reference for this release.

VTP Configuration in Global Configuration Mode

You can use the **vtp** global configuration command to set the VTP password, the version, the VTP file name, the interface providing updated VTP information, the domain name, and the mode, and to disable or enable pruning. For more information about available keywords, see the command descriptions in the command reference for this release. The VTP information is saved in the VTP VLAN database. When VTP mode is transparent, the VTP domain name and mode are also saved in the switch running configuration file, and you can save it in the switch startup configuration file by entering the **copy running-config startup-config** privileged EXEC command. You must use this command if you want to save VTP mode as transparent, even if the switch resets.

When you save VTP information in the switch startup configuration file and reboot the switch, the switch configuration is selected as follows:

- If the VTP mode is transparent in the startup configuration and the VLAN database and the VTP domain name from the VLAN database matches that in the startup configuration file, the VLAN database is ignored (cleared), and the VTP and VLAN configurations in the startup configuration file are used. The VLAN database revision number remains unchanged in the VLAN database.
- If the VTP mode or domain name in the startup configuration do not match the VLAN database, the domain name and VTP mode and configuration for the first 255 VLANs use the VLAN database information.

VTP Configuration in VLAN Database Configuration Mode

You can configure all VTP parameters in VLAN database configuration mode, which you access by entering the **vlan database** privileged EXEC command. For more information about available keywords, see the **vtp** VLAN database configuration command description in the command reference for this release. When you enter the **exit** command in VLAN database configuration mode, it applies all the commands that you entered and updates the VLAN database. VTP messages are sent to other switches in the VTP domain, and the privileged EXEC mode prompt appears.

If VTP mode is transparent, the domain name and the mode (transparent) are saved in the switch running configuration, and you can save this information in the switch startup configuration file by entering the **copy running-config startup-config** privileged EXEC command.

VTP Configuration Guidelines

These sections describe guidelines you should follow when implementing VTP in your network.

Domain Names

When configuring VTP for the first time, you must always assign a domain name. You must configure all switches in the VTP domain with the same domain name. Switches in VTP transparent mode do not exchange VTP messages with other switches, and you do not need to configure a VTP domain name for them.

**Note**

If NVRAM and DRAM storage is sufficient, all switches in a VTP domain should be in VTP server mode.

**Caution**

Do not configure a VTP domain if all switches are operating in VTP client mode. If you configure the domain, it is impossible to make changes to the VLAN configuration of that domain. Make sure that you configure at least one switch in the VTP domain for VTP server mode.

Passwords

You can configure a password for the VTP domain, but it is not required. If you do configure a domain password, all domain switches must share the same password and you must configure the password on each switch in the management domain. Switches without a password or with the wrong password reject VTP advertisements.

If you configure a VTP password for a domain, a switch that is booted without a VTP configuration does not accept VTP advertisements until you configure it with the correct password. After the configuration, the switch accepts the next VTP advertisement that uses the same password and domain name in the advertisement.

If you are adding a new switch to an existing network with VTP capability, the new switch learns the domain name only after the applicable password has been configured on it.

**Caution**

When you configure a VTP domain password, the management domain does not function properly if you do not assign a management domain password to each switch in the domain.

VTP Version

Follow these guidelines when deciding which VTP version to implement:

- All switches in a VTP domain must run the same VTP version.
- A VTP Version 2-capable switch can operate in the same VTP domain as a switch running VTP Version 1 if Version 2 is disabled on the Version 2-capable switch (Version 2 is disabled by default).

- Do not enable VTP Version 2 on a switch unless all of the switches in the same VTP domain are Version-2-capable. When you enable Version 2 on a switch, all of the Version-2-capable switches in the domain enable Version 2. If there is a Version 1-only switch, it does not exchange VTP information with switches that have Version 2 enabled.
- If there are TrBRF and TrCRF Token Ring networks in your environment, you must enable VTP Version 2 for Token Ring VLAN switching to function properly. To run Token Ring and Token Ring-Net, disable VTP Version 2.

Configuration Requirements

When you configure VTP, you must configure a trunk port so that the switch can send and receive VTP advertisements to and from other switches in the domain.

For more information, see the [“Configuring VLAN Trunks”](#) section on page 12-14.

If you are configuring VTP on a cluster member switch to a VLAN, use the **rcommand** privileged EXEC command to log in to the member switch. For more information about the command, see the command reference for this release.

If you are configuring extended-range VLANs on the switch, the switch must be in VTP transparent mode.

Configuring a VTP Server

When a switch is in VTP server mode, you can change the VLAN configuration and have it propagated throughout the network.



Note

If extended-range VLANs are configured on the switch, you cannot change VTP mode to server. You receive an error message, and the configuration is not allowed.

Beginning in privileged EXEC mode, follow these steps to configure the switch as a VTP server:

	Command	Purpose
Step 1	configure terminal	Enter global configuration mode.
Step 2	vtp mode server	Configure the switch for VTP server mode (the default).
Step 3	vtp domain <i>domain-name</i>	Configure the VTP administrative-domain name. The name can be 1 to 32 characters. All switches operating in VTP server or client mode under the same administrative responsibility must be configured with the same domain name.
Step 4	vtp password <i>password</i>	(Optional) Set the password for the VTP domain. The password can be 8 to 64 characters. If you configure a VTP password, the VTP domain does not function properly if you do not assign the same password to each switch in the domain.
Step 5	end	Return to privileged EXEC mode.
Step 6	show vtp status	Verify your entries in the <i>VTP Operating Mode</i> and the <i>VTP Domain Name</i> fields of the display.

When you configure a domain name, it cannot be removed; you can only reassign a switch to a different domain.

To return the switch to a no-password state, use the **no vtp password** global configuration command.

This example shows how to use global configuration mode to configure the switch as a VTP server with the domain name *eng_group* and the password *mypassword*:

```
Switch# config terminal
Switch(config)# vtp mode server
Switch(config)# vtp domain eng_group
Switch(config)# vtp password mypassword
Switch(config)# end
```

You can also use VLAN database configuration mode to configure VTP parameters.

Beginning in privileged EXEC mode, follow these steps to use VLAN database configuration mode to configure the switch as a VTP server:

	Command	Purpose
Step 1	vlan database	Enter VLAN database configuration mode.
Step 2	vtp server	Configure the switch for VTP server mode (the default).
Step 3	vtp domain <i>domain-name</i>	Configure a VTP administrative-domain name. The name can be 1 to 32 characters. All switches operating in VTP server or client mode under the same administrative responsibility must be configured with the same domain name.
Step 4	vtp password <i>password</i>	(Optional) Set a password for the VTP domain. The password can be 8 to 64 characters. If you configure a VTP password, the VTP domain does not function properly if you do not assign the same password to each switch in the domain.
Step 5	exit	Update the VLAN database, propagate it throughout the administrative domain, and return to privileged EXEC mode.
Step 6	show vtp status	Verify your entries in the <i>VTP Operating Mode</i> and the <i>VTP Domain Name</i> fields of the display.

When you configure a domain name, it cannot be removed; you can only reassign a switch to a different domain.

To return the switch to a no-password state, use the **no vtp password** VLAN database configuration command.

This example shows how to use VLAN database configuration mode to configure the switch as a VTP server with the domain name *eng_group* and the password *mypassword*:

```
Switch# vlan database
Switch(vlan)# vtp server
Switch(vlan)# vtp domain eng_group
Switch(vlan)# vtp password mypassword
Switch(vlan)# exit
APPLY completed.
Exiting...
Switch#
```

Configuring a VTP Client

When a switch is in VTP client mode, you cannot change its VLAN configuration. The client switch receives VTP updates from a VTP server in the VTP domain and then modifies its configuration accordingly.

Follow these guidelines:

- If extended-range VLANs are configured on the switch, you cannot change VTP mode to client. You receive an error message, and the configuration is not allowed.
- If you configure the switch for VTP client mode, the switch does not create the VLAN database file (vlan.dat). If the switch is then powered off, it resets the VTP configuration to the default. To keep the VTP configuration with VTP client mode after the switch restarts, you must first configure the VTP domain name before the VTP mode.



Caution

If all switches are operating in VTP client mode, do not configure a VTP domain name. If you do, it is impossible to make changes to the VLAN configuration of that domain. Therefore, make sure you configure at least one switch as a VTP server.

Beginning in privileged EXEC mode, follow these steps to configure the switch as a VTP client:

	Command	Purpose
Step 1	configure terminal	Enter global configuration mode.
Step 2	vtp mode client	Configure the switch for VTP client mode. The default setting is VTP server.
Step 3	vtp domain <i>domain-name</i>	(Optional) Enter the VTP administrative-domain name. The name can be 1 to 32 characters. This should be the same domain name as the VTP server. All switches operating in VTP server or client mode under the same administrative responsibility must be configured with the same domain name.
Step 4	vtp password <i>password</i>	(Optional) Enter the password for the VTP domain.
Step 5	end	Return to privileged EXEC mode.
Step 6	show vtp status	Verify your entries in the <i>VTP Operating Mode</i> and the <i>VTP Domain Name</i> fields of the display.

Use the **no vtp mode** global configuration command to return the switch to VTP server mode. To return the switch to a no-password state, use the **no vtp password** privileged EXEC command. When you configure a domain name, it cannot be removed; you can only reassign a switch to a different domain.



Note

You can also configure a VTP client by using the **vlan database** privileged EXEC command to enter VLAN database configuration mode and entering the **vtp client** command, similar to the second procedure under “[Configuring a VTP Server](#)” section on page 13-9. Use the **no vtp client** VLAN database configuration command to return the switch to VTP server mode or the **no vtp password** VLAN database configuration command to return the switch to a no-password state. When you configure a domain name, it cannot be removed; you can only reassign a switch to a different domain.

Disabling VTP (VTP Transparent Mode)

When you configure the switch for VTP transparent mode, VTP is disabled on the switch. The switch does not send VTP updates and does not act on VTP updates received from other switches. However, a VTP transparent switch running VTP Version 2 does forward received VTP advertisements on its trunk links.



Note

Before you create extended-range VLANs (VLAN IDs 1006 to 4094), you must set VTP mode to transparent by using the **vtp mode transparent** global configuration command. Save this configuration to the startup configuration so that the switch boots up in VTP transparent mode. Otherwise, you lose the extended-range VLAN configuration if the switch resets and boots up in VTP server mode (the default).

Beginning in privileged EXEC mode, follow these steps to configure VTP transparent mode and save the VTP configuration in the switch startup configuration file:

	Command	Purpose
Step 1	configure terminal	Enter global configuration mode.
Step 2	vtp mode transparent	Configure the switch for VTP transparent mode (disable VTP).
Step 3	end	Return to privileged EXEC mode.
Step 4	show vtp status	Verify your entries in the <i>VTP Operating Mode</i> and the <i>VTP Domain Name</i> fields of the display.
Step 5	copy running-config startup-config	(Optional) Save the configuration in the startup configuration file. Note Only VTP mode and domain name are saved in the switch running configuration and can be copied to the startup configuration file.

To return the switch to VTP server mode, use the **no vtp mode** global configuration command.



Note

If extended-range VLANs are configured on the switch, you cannot change the VTP mode to server. You receive an error message, and the configuration is not allowed.



Note

You can also configure VTP transparent mode by using the **vlan database** privileged EXEC command to enter VLAN database configuration mode and by entering the **vtp transparent** command, similar to the second procedure under the “[Configuring a VTP Server](#)” section on page 13-9. Use the **no vtp transparent** VLAN database configuration command to return the switch to VTP server mode. If extended-range VLANs are configured on the switch, you cannot change VTP mode to server. You receive an error message, and the configuration is not allowed.

Enabling VTP Version 2

VTP Version 2 is disabled by default on VTP Version 2-capable switches. When you enable VTP Version 2 on a switch, every VTP Version 2-capable switch in the VTP domain enables Version 2. You can only configure the version when the switches are in VTP server or transparent mode.



Caution

VTP Version 1 and VTP Version 2 are not interoperable on switches in the same VTP domain. Every switch in the VTP domain must use the same VTP version. Do not enable VTP Version 2 unless every switch in the VTP domain supports Version 2.



Note

In TrCRF and TrBRF Token ring environments, you must enable VTP Version 2 for Token Ring VLAN switching to function properly. For Token Ring and Token Ring-Net media, VTP Version 2 must be disabled.

For more information on VTP version configuration guidelines, see the “[VTP Version](#)” section on page 13-8.

Beginning in privileged EXEC mode, follow these steps to enable VTP Version 2:

	Command	Purpose
Step 1	configure terminal	Enter global configuration mode.
Step 2	vtp version 2	Enable VTP Version 2 on the switch. VTP Version 2 is disabled by default on VTP Version 2-capable switches.
Step 3	end	Return to privileged EXEC mode.
Step 4	show vtp status	In the <i>VTP V2 Mode</i> field of the display, verify that VTP Version 2 is enabled.

To disable VTP Version 2, use the **no vtp version** global configuration command.



Note

You can also enable VTP Version 2 by using the **vlan database** privileged EXEC command to enter VLAN database configuration mode and by entering the **vtp v2-mode** VLAN database configuration command. To disable VTP Version 2, use the **no vtp v2-mode** VLAN database configuration command.

Enabling VTP Pruning

Pruning increases available bandwidth by restricting flooded traffic to those trunk links that the traffic must use to access the destination devices. You can only enable VTP pruning on a switch in VTP server mode.

Beginning in privileged EXEC mode, follow these steps to enable VTP pruning in the VTP domain:

	Command	Purpose
Step 1	<code>configure terminal</code>	Enter global configuration mode.
Step 2	<code>vtp pruning</code>	Enable pruning in the VTP administrative domain. By default, pruning is disabled. You need to enable pruning on only one switch in VTP server mode.
Step 3	<code>end</code>	Return to privileged EXEC mode.
Step 4	<code>show vtp status</code>	Verify your entries in the <i>VTP Pruning Mode</i> field of the display.

To disable VTP pruning, use the **no vtp pruning** global configuration command.



Note

You can also enable VTP pruning by using the **vlan database** privileged EXEC command to enter VLAN database configuration mode and entering the **vtp pruning** VLAN database configuration command. To disable VTP pruning, use the **no vtp pruning** VLAN database configuration command. You can also enable VTP Version 2 by using the **vtp pruning** privileged EXEC command.

Pruning is supported with VTP Version 1 and Version 2. If you enable pruning on the VTP server, it is enabled for the entire VTP domain.

Only VLANs included in the pruning-eligible list can be pruned. By default, VLANs 2 through 1001 are pruning-eligible on trunk ports. Reserved VLANs and extended-range VLANs cannot be pruned. To change the pruning-eligible VLANs, see the [“Changing the Pruning-Eligible List”](#) section on page 12-19.

Adding a VTP Client Switch to a VTP Domain

Before adding a VTP client to a VTP domain, always verify that its VTP configuration revision number is *lower* than the configuration revision number of the other switches in the VTP domain. Switches in a VTP domain always use the VLAN configuration of the switch with the highest VTP configuration revision number. If you add a switch that has a revision number higher than the revision number in the VTP domain, it can erase all VLAN information from the VTP server and VTP domain.

Beginning in privileged EXEC mode, follow these steps to verify and reset the VTP configuration revision number on a switch *before* adding it to a VTP domain:

	Command	Purpose
Step 1	show vtp status	Check the VTP configuration revision number. If the number is 0, add the switch to the VTP domain. If the number is greater than 0, follow these steps: <ol style="list-style-type: none"> a. Write down the domain name. b. Write down the configuration revision number. c. Continue with the next steps to reset the switch configuration revision number.
Step 2	configure terminal	Enter global configuration mode.
Step 3	vtp domain <i>domain-name</i>	Change the domain name from the original one displayed in Step 1 to a new name.
Step 4	end	The VLAN information on the switch is updated and the configuration revision number is reset to 0. You return to privileged EXEC mode.
Step 5	show vtp status	Verify that the configuration revision number has been reset to 0.
Step 6	configure terminal	Enter global configuration mode.
Step 7	vtp domain <i>domain-name</i>	Enter the original domain name on the switch.
Step 8	end	The VLAN information on the switch is updated, and you return to privileged EXEC mode.
Step 9	show vtp status	(Optional) Verify that the domain name is the same as in Step 1 and that the configuration revision number is 0.

You can also change the VTP domain name by entering the **vlan database** privileged EXEC command to enter VLAN database configuration mode and by entering the **vtp domain** *domain-name* command. In this mode, you must enter the **exit** command to update VLAN information and return to privileged EXEC mode.

After resetting the configuration revision number, add the switch to the VTP domain.



Note

You can use the **vtp mode transparent** global configuration command or the **vtp transparent** VLAN database configuration command to disable VTP on the switch, and then change its VLAN information without affecting the other switches in the VTP domain.

Monitoring VTP

You monitor VTP by displaying VTP configuration information: the domain name, the current VTP revision, and the number of VLANs. You can also display statistics about the advertisements sent and received by the switch.

Table 13-3 shows the privileged EXEC commands for monitoring VTP activity.

Table 13-3 VTP Monitoring Commands

Command	Purpose
<code>show vtp status</code>	Display the VTP switch configuration information.
<code>show vtp counters</code>	Display counters about VTP messages that have been sent and received.



CHAPTER 14

Configuring Voice VLAN

This chapter describes how to configure the voice VLAN feature on the Catalyst 2960 switch. Voice VLAN is referred to as an *auxiliary VLAN* in some Catalyst 6500 family switch documentation.



Note

For complete syntax and usage information for the commands used in this chapter, see the command reference for this release.

This chapter consists of these sections:

- [Understanding Voice VLAN, page 14-1](#)
- [Configuring Voice VLAN, page 14-3](#)
- [Displaying Voice VLAN, page 14-6](#)

Understanding Voice VLAN

The voice VLAN feature enables access ports to carry IP voice traffic from an IP phone. When the switch is connected to a Cisco 7960 IP Phone, the phone sends voice traffic with Layer 3 IP precedence and Layer 2 class of service (CoS) values, which are both set to 5 by default. Because the sound quality of an IP phone call can deteriorate if the data is unevenly sent, the switch supports quality of service (QoS) based on IEEE 802.1p CoS. QoS uses classification and scheduling to send network traffic from the switch in a predictable manner. For more information on QoS, see [Chapter 28, “Configuring QoS.”](#)

The Cisco 7960 IP Phone is a configurable device, and you can configure it to forward traffic with an IEEE 802.1p priority. You can configure the switch to trust or override the traffic priority assigned by a Cisco IP Phone.

The Cisco IP Phone contains an integrated three-port 10/100 switch as shown in [Figure 14-1](#). The ports provide dedicated connections to these devices:

- Port 1 connects to the switch or other voice-over-IP (VoIP) device.
- Port 2 is an internal 10/100 interface that carries the IP Phone traffic.
- Port 3 (access port) connects to a PC or other device.

Figure 14-1 shows one way to connect a Cisco 7960 IP Phone.

Figure 14-1 Cisco 7960 IP Phone Connected to a Switch

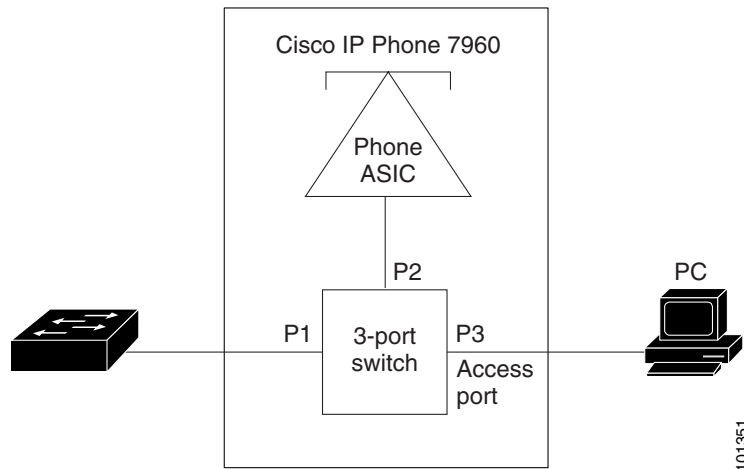

Cisco IP Phone Voice Traffic

You can configure an access port with an attached Cisco IP Phone to use one VLAN for voice traffic and another VLAN for data traffic from a device attached to the phone. You can configure access ports on the switch to send Cisco Discovery Protocol (CDP) packets that instruct an attached phone to send voice traffic to the switch in any of these ways:

- In the voice VLAN tagged with a Layer 2 CoS priority value
- In the access VLAN tagged with a Layer 2 CoS priority value
- In the access VLAN, untagged (no Layer 2 CoS priority value)



Note

In all configurations, the voice traffic carries a Layer 3 IP precedence value (the default is 5 for voice traffic and 3 for voice control traffic).

Cisco IP Phone Data Traffic

The switch can also process tagged data traffic (traffic in IEEE 802.1Q or IEEE 802.1p frame types) from the device attached to the access port on the Cisco IP Phone (see Figure 14-1). You can configure Layer 2 access ports on the switch to send CDP packets that instruct the attached phone to configure the phone access port in one of these modes:

- In trusted mode, all traffic received through the access port on the Cisco IP Phone passes through the phone unchanged.
- In untrusted mode, all traffic in IEEE 802.1Q or IEEE 802.1p frames received through the access port on the Cisco IP Phone receive a configured Layer 2 CoS value. The default Layer 2 CoS value is 0. Untrusted mode is the default.

**Note**

Untagged traffic from the device attached to the Cisco IP Phone passes through the phone unchanged, regardless of the trust state of the access port on the phone.

Configuring Voice VLAN

These sections contain this configuration information:

- [Default Voice VLAN Configuration, page 14-3](#)
- [Voice VLAN Configuration Guidelines, page 14-3](#)
- [Configuring a Port Connected to a Cisco 7960 IP Phone, page 14-4](#)

Default Voice VLAN Configuration

The voice VLAN feature is disabled by default.

When the voice VLAN feature is enabled, all untagged traffic is sent according to the default CoS priority of the port.

The CoS value is not trusted for IEEE 802.1p or IEEE 802.1Q tagged traffic.

Voice VLAN Configuration Guidelines

These are the voice VLAN configuration guidelines:

- You should configure voice VLAN on switch access ports; voice VLAN is not supported on trunk ports.

**Note**

Voice VLAN is only supported on access ports and not on trunk ports, even though the configuration is allowed.

- The voice VLAN should be present and active on the switch for the IP phone to correctly communicate on the voice VLAN. Use the **show vlan** privileged EXEC command to see if the VLAN is present (listed in the display). If the VLAN is not listed, see [Chapter 12, “Configuring VLANs,”](#) for information on how to create the voice VLAN.
- Before you enable voice VLAN, we recommend that you enable QoS on the switch by entering the **mls qos** global configuration command and configure the port trust state to trust by entering the **mls qos trust cos** interface configuration command. If you use the auto-QoS feature, these settings are automatically configured. For more information, see [Chapter 28, “Configuring QoS.”](#)
- You must enable CDP on the switch port connected to the Cisco IP Phone to send the configuration to the phone. (CDP is globally enabled by default on all switch interfaces.)
- The Port Fast feature is automatically enabled when voice VLAN is configured. When you disable voice VLAN, the Port Fast feature is not automatically disabled.
- If the Cisco IP Phone and a device attached to the phone are in the same VLAN, they must be in the same IP subnet. These conditions indicate that they are in the same VLAN:
 - They both use IEEE 802.1p or untagged frames.

- The Cisco IP Phone uses IEEE 802.1p frames, and the device uses untagged frames.
- The Cisco IP Phone uses untagged frames, and the device uses IEEE 802.1p frames.
- The Cisco IP Phone uses IEEE 802.1Q frames, and the voice VLAN is the same as the access VLAN.
- The Cisco IP Phone and a device attached to the phone cannot communicate if they are in the same VLAN and subnet but use different frame types because traffic in the same subnet is not routed (routing would eliminate the frame type difference).
- You cannot configure static secure MAC addresses in the voice VLAN.
- Voice VLAN ports can also be these port types:
 - Dynamic access port. See the [“Configuring Dynamic-Access Ports on VMPS Clients” section on page 12-26](#) for more information.
 - IEEE 802.1x authenticated port. See the [“Configuring IEEE 802.1x Authentication” section on page 9-22](#) for more information.



Note If you enable IEEE 802.1x on an access port on which a voice VLAN is configured and to which a Cisco IP Phone is connected, the phone loses connectivity to the switch for up to 30 seconds.

- Protected port. See the [“Configuring Protected Ports” section on page 19-5](#) for more information.
- A source or destination port for a SPAN or RSPAN session.
- Secure port. See the [“Configuring Port Security” section on page 19-8](#) for more information.



Note When you enable port security on an interface that is also configured with a voice VLAN, you must set the maximum allowed secure addresses on the port to two plus the maximum number of secure addresses allowed on the access VLAN. When the port is connected to a Cisco IP Phone, the phone requires up to two MAC addresses. The phone address is learned on the voice VLAN and might also be learned on the access VLAN. Connecting a PC to the phone requires additional MAC addresses.

Configuring a Port Connected to a Cisco 7960 IP Phone

Because a Cisco 7960 IP Phone also supports a connection to a PC or other device, a port connecting the switch to a Cisco IP Phone can carry mixed traffic. You can configure a port to decide how the Cisco IP Phone carries voice traffic and data traffic.

These sections contain this configuration information:

- [Configuring Cisco IP Phone Voice Traffic, page 14-4](#)
- [Configuring the Priority of Incoming Data Frames, page 14-6](#)

Configuring Cisco IP Phone Voice Traffic

You can configure a port connected to the Cisco IP Phone to send CDP packets to the phone to configure the way in which the phone sends voice traffic. The phone can carry voice traffic in IEEE 802.1Q frames for a specified voice VLAN with a Layer 2 CoS value. It can use IEEE 802.1p priority tagging to give

voice traffic a higher priority and forward all voice traffic through the native (access) VLAN. The Cisco IP Phone can also send untagged voice traffic or use its own configuration to send voice traffic in the access VLAN. In all configurations, the voice traffic carries a Layer 3 IP precedence value (the default is 5).

Beginning in privileged EXEC mode, follow these steps to configure voice traffic on a port:

	Command	Purpose
Step 1	configure terminal	Enter global configuration mode.
Step 2	interface <i>interface-id</i>	Specify the interface connected to the phone, and enter interface configuration mode.
Step 3	mls qos trust cos	Configure the interface to classify incoming traffic packets by using the packet CoS value. For untagged packets, the port default CoS value is used. Note Before configuring the port trust state, you must first globally enable QoS by using the mls qos global configuration command.
Step 4	switchport voice vlan { <i>vlan-id</i> dot1p none untagged }	Configure how the Cisco IP Phone carries voice traffic: <ul style="list-style-type: none"> • vlan-id—Configure the phone to forward all voice traffic through the specified VLAN. By default, the Cisco IP Phone forwards the voice traffic with an IEEE 802.1Q priority of 5. Valid VLAN IDs are 1 to 4094. • dot1p—Configure the phone to use IEEE 802.1p priority tagging for voice traffic and to use the default native VLAN (VLAN 0) to carry all traffic. By default, the Cisco IP Phone forwards the voice traffic with an IEEE 802.1p priority of 5. • none—Allow the phone to use its own configuration to send untagged voice traffic. • untagged—Configure the phone to send untagged voice traffic.
Step 5	end	Return to privileged EXEC mode.
Step 6	show interfaces <i>interface-id</i> switchport or show running-config interface <i>interface-id</i>	Verify your voice VLAN entries. Verify your QoS and voice VLAN entries.
Step 7	copy running-config startup-config	(Optional) Save your entries in the configuration file.

This example shows how to configure a port connected to a Cisco IP Phone to use the CoS value to classify incoming traffic, to use IEEE 802.1p priority tagging for voice traffic, and to use the default native VLAN (VLAN 0) to carry all traffic:

```
Switch# configure terminal
Enter configuration commands, one per line. End with CNTL/Z.
Switch(config)# interface gigabitethernet0/1
Switch(config-if)# mls qos trust cos
Switch(config-if)# switchport voice vlan dot1p
Switch(config-if)# end
```

To return the port to its default setting, use the **no switchport voice vlan** interface configuration command.

Configuring the Priority of Incoming Data Frames

You can connect a PC or other data device to a Cisco IP Phone port. To process tagged data traffic (in IEEE 802.1Q or IEEE 802.1p frames), you can configure the switch to send CDP packets to instruct the phone how to send data packets from the device attached to the access port on the Cisco IP Phone. The PC can generate packets with an assigned CoS value. You can configure the phone to not change (trust) or to override (not trust) the priority of frames arriving on the phone port from connected devices.

Beginning in privileged EXEC mode, follow these steps to set the priority of data traffic received from the nonvoice port on the Cisco IP Phone:

	Command	Purpose
Step 1	configure terminal	Enter global configuration mode.
Step 2	interface <i>interface-id</i>	Specify the interface connected to the Cisco IP Phone, and enter interface configuration mode.
Step 3	switchport priority extend { <i>cos value</i> trust }	Set the priority of data traffic received from the Cisco IP Phone access port: <ul style="list-style-type: none"> cos value—Configure the phone to override the priority received from the PC or the attached device with the specified CoS value. The value is a number from 0 to 7, with 7 as the highest priority. The default priority is cos 0. trust—Configure the phone access port to trust the priority received from the PC or the attached device.
Step 4	end	Return to privileged EXEC mode.
Step 5	show interfaces <i>interface-id</i> switchport	Verify your entries.
Step 6	copy running-config startup-config	(Optional) Save your entries in the configuration file.

This example shows how to configure a port connected to a Cisco IP Phone to not change the priority of frames received from the PC or the attached device:

```
Switch# configure terminal
Enter configuration commands, one per line. End with CNTL/Z.
Switch(config)# interface gigabitethernet0/1
Switch(config-if)# switchport priority extend trust
Switch(config-if)# end
```

To return the port to its default setting, use the **no switchport priority extend** interface configuration command.

Displaying Voice VLAN

To display voice VLAN configuration for an interface, use the **show interfaces interface-id switchport** privileged EXEC command.



CHAPTER 15

Configuring STP

This chapter describes how to configure the Spanning Tree Protocol (STP) on port-based VLANs on the Catalyst 2960 switch. The switch can use either the per-VLAN spanning-tree plus (PVST+) protocol based on the IEEE 802.1D standard and Cisco proprietary extensions, or the rapid per-VLAN spanning-tree plus (rapid-PVST+) protocol based on the IEEE 802.1w standard.

For information about the Multiple Spanning Tree Protocol (MSTP) and how to map multiple VLANs to the same spanning-tree instance, see [Chapter 16, “Configuring MSTP.”](#) For information about other spanning-tree features such as Port Fast, UplinkFast, root guard, and so forth, see [Chapter 17, “Configuring Optional Spanning-Tree Features.”](#)



Note

For complete syntax and usage information for the commands used in this chapter, see the command reference for this release.

This chapter consists of these sections:

- [Understanding Spanning-Tree Features, page 15-1](#)
- [Configuring Spanning-Tree Features, page 15-10](#)
- [Displaying the Spanning-Tree Status, page 15-22](#)

Understanding Spanning-Tree Features

These sections contain this conceptual information:

- [STP Overview, page 15-2](#)
- [Spanning-Tree Topology and BPDUs, page 15-3](#)
- [Bridge ID, Switch Priority, and Extended System ID, page 15-4](#)
- [Spanning-Tree Interface States, page 15-4](#)
- [How a Switch or Port Becomes the Root Switch or Root Port, page 15-7](#)
- [Spanning Tree and Redundant Connectivity, page 15-8](#)
- [Spanning-Tree Address Management, page 15-8](#)
- [Accelerated Aging to Retain Connectivity, page 15-8](#)
- [Spanning-Tree Modes and Protocols, page 15-9](#)
- [Supported Spanning-Tree Instances, page 15-9](#)

- [Spanning-Tree Interoperability and Backward Compatibility](#), page 15-10
- [STP and IEEE 802.1Q Trunks](#), page 15-10

For configuration information, see the “[Configuring Spanning-Tree Features](#)” section on page 15-10.

For information about optional spanning-tree features, see [Chapter 17, “Configuring Optional Spanning-Tree Features.”](#)

STP Overview

STP is a Layer 2 link management protocol that provides path redundancy while preventing loops in the network. For a Layer 2 Ethernet network to function properly, only one active path can exist between any two stations. Multiple active paths among end stations cause loops in the network. If a loop exists in the network, end stations might receive duplicate messages. Switches might also learn end-station MAC addresses on multiple Layer 2 interfaces. These conditions result in an unstable network. Spanning-tree operation is transparent to end stations, which cannot detect whether they are connected to a single LAN segment or a switched LAN of multiple segments.

The STP uses a spanning-tree algorithm to select one switch of a redundantly connected network as the root of the spanning tree. The algorithm calculates the best loop-free path through a switched Layer 2 network by assigning a role to each port based on the role of the port in the active topology:

- **Root**—A forwarding port elected for the spanning-tree topology
- **Designated**—A forwarding port elected for every switched LAN segment
- **Alternate**—A blocked port providing an alternate path to the root bridge in the spanning tree
- **Backup**—A blocked port in a loopback configuration

The switch that has *all* of its ports as the designated role or as the backup role is the root switch. The switch that has at least *one* of its ports in the designated role is called the designated switch.

Spanning tree forces redundant data paths into a standby (blocked) state. If a network segment in the spanning tree fails and a redundant path exists, the spanning-tree algorithm recalculates the spanning-tree topology and activates the standby path. Switches send and receive spanning-tree frames, called bridge protocol data units (BPDUs), at regular intervals. The switches do not forward these frames but use them to construct a loop-free path. BPDUs contain information about the sending switch and its ports, including switch and MAC addresses, switch priority, port priority, and path cost. Spanning tree uses this information to elect the root switch and root port for the switched network and the root port and designated port for each switched segment.

When two ports on a switch are part of a loop, the spanning-tree port priority and path cost settings control which port is put in the forwarding state and which is put in the blocking state. The spanning-tree port priority value represents the location of a port in the network topology and how well it is located to pass traffic. The path cost value represents the media speed.



Note

The default is for the switch to send keepalive messages (to ensure the connection is up) only on interfaces that do not have small form-factor pluggable (SFP) modules. You can use the **[no] keepalive** interface configuration command to change the default for an interface.

Spanning-Tree Topology and BPDUs

The stable, active spanning-tree topology of a switched network is controlled by these elements:

- The unique bridge ID (switch priority and MAC address) associated with each VLAN on each switch.
- The spanning-tree path cost to the root switch.
- The port identifier (port priority and MAC address) associated with each Layer 2 interface.

When the switches in a network are powered up, each functions as the root switch. Each switch sends a configuration BPDU through all of its ports. The BPDUs communicate and compute the spanning-tree topology. Each configuration BPDU contains this information:

- The unique bridge ID of the switch that the sending switch identifies as the root switch
- The spanning-tree path cost to the root
- The bridge ID of the sending switch
- Message age
- The identifier of the sending interface
- Values for the hello, forward delay, and max-age protocol timers

When a switch receives a configuration BPDU that contains *superior* information (lower bridge ID, lower path cost, and so forth), it stores the information for that port. If this BPDU is received on the root port of the switch, the switch also forwards it with an updated message to all attached LANs for which it is the designated switch.

If a switch receives a configuration BPDU that contains *inferior* information to that currently stored for that port, it discards the BPDU. If the switch is a designated switch for the LAN from which the inferior BPDU was received, it sends that LAN a BPDU containing the up-to-date information stored for that port. In this way, inferior information is discarded, and superior information is propagated on the network.

A BPDU exchange results in these actions:

- One switch in the network is elected as the root switch (the logical center of the spanning-tree topology in a switched network).
For each VLAN, the switch with the highest switch priority (the lowest numerical priority value) is elected as the root switch. If all switches are configured with the default priority (32768), the switch with the lowest MAC address in the VLAN becomes the root switch. The switch priority value occupies the most significant bits of the bridge ID, as shown in [Table 15-1 on page 15-4](#).
- A root port is selected for each switch (except the root switch). This port provides the best path (lowest cost) when the switch forwards packets to the root switch.
- The shortest distance to the root switch is calculated for each switch based on the path cost.
- A designated switch for each LAN segment is selected. The designated switch incurs the lowest path cost when forwarding packets from that LAN to the root switch. The port through which the designated switch is attached to the LAN is called the designated port.

All paths that are not needed to reach the root switch from anywhere in the switched network are placed in the spanning-tree blocking mode.

Bridge ID, Switch Priority, and Extended System ID

The IEEE 802.1D standard requires that each switch has a unique bridge identifier (bridge ID), which controls the selection of the root switch. Because each VLAN is considered as a different *logical bridge* with PVST+ and rapid PVST+, the same switch must have a different bridge IDs for each configured VLAN. Each VLAN on the switch has a unique 8-byte bridge ID. The 2 most-significant bytes are used for the switch priority, and the remaining 6 bytes are derived from the switch MAC address.

The switch supports the IEEE 802.1t spanning-tree extensions, and some of the bits previously used for the switch priority are now used as the VLAN identifier. The result is that fewer MAC addresses are reserved for the switch, and a larger range of VLAN IDs can be supported, all while maintaining the uniqueness of the bridge ID. As shown in [Table 15-1](#), the 2 bytes previously used for the switch priority are reallocated into a 4-bit priority value and a 12-bit extended system ID value equal to the VLAN ID.

Table 15-1 Switch Priority Value and Extended System ID

Switch Priority Value				Extended System ID (Set Equal to the VLAN ID)											
Bit 16	Bit 15	Bit 14	Bit 13	Bit 12	Bit 11	Bit 10	Bit 9	Bit 8	Bit 7	Bit 6	Bit 5	Bit 4	Bit 3	Bit 2	Bit 1
32768	16384	8192	4096	2048	1024	512	256	128	64	32	16	8	4	2	1

Spanning tree uses the extended system ID, the switch priority, and the allocated spanning-tree MAC address to make the bridge ID unique for each VLAN.

Support for the extended system ID affects how you manually configure the root switch, the secondary root switch, and the switch priority of a VLAN. For example, when you change the switch priority value, you change the probability that the switch will be elected as the root switch. Configuring a higher value decreases the probability; a lower value increases the probability. For more information, see the [“Configuring the Root Switch”](#) section on page 15-14, the [“Configuring a Secondary Root Switch”](#) section on page 15-16, and the [“Configuring the Switch Priority of a VLAN”](#) section on page 15-19.

Spanning-Tree Interface States

Propagation delays can occur when protocol information passes through a switched LAN. As a result, topology changes can take place at different times and at different places in a switched network. When an interface transitions directly from nonparticipation in the spanning-tree topology to the forwarding state, it can create temporary data loops. Interfaces must wait for new topology information to propagate through the switched LAN before starting to forward frames. They must allow the frame lifetime to expire for forwarded frames that have used the old topology.

Each Layer 2 interface on a switch using spanning tree exists in one of these states:

- **Blocking**—The interface does not participate in frame forwarding.
- **Listening**—The first transitional state after the blocking state when the spanning tree decides that the interface should participate in frame forwarding.
- **Learning**—The interface prepares to participate in frame forwarding.
- **Forwarding**—The interface forwards frames.
- **Disabled**—The interface is not participating in spanning tree because of a shutdown port, no link on the port, or no spanning-tree instance running on the port.

An interface moves through these states:

- From initialization to blocking
- From blocking to listening or to disabled
- From listening to learning or to disabled
- From learning to forwarding or to disabled
- From forwarding to disabled

Figure 15-1 illustrates how an interface moves through the states.

Figure 15-1 Spanning-Tree Interface States

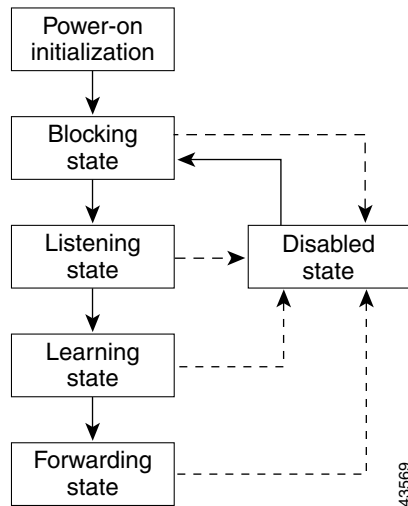

When you power up the switch, spanning tree is enabled by default, and every interface in the switch, VLAN, or network goes through the blocking state and the transitory states of listening and learning. Spanning tree stabilizes each interface at the forwarding or blocking state.

When the spanning-tree algorithm places a Layer 2 interface in the forwarding state, this process occurs:

1. The interface is in the listening state while spanning tree waits for protocol information to move the interface to the blocking state.
2. While spanning tree waits the forward-delay timer to expire, it moves the interface to the learning state and resets the forward-delay timer.
3. In the learning state, the interface continues to block frame forwarding as the switch learns end-station location information for the forwarding database.
4. When the forward-delay timer expires, spanning tree moves the interface to the forwarding state, where both learning and frame forwarding are enabled.

Blocking State

A Layer 2 interface in the blocking state does not participate in frame forwarding. After initialization, a BPDU is sent to each switch interface. A switch initially functions as the root until it exchanges BPDUs with other switches. This exchange establishes which switch in the network is the root or root switch. If there is only one switch in the network, no exchange occurs, the forward-delay timer expires, and the interface moves to the listening state. An interface always enters the blocking state after switch initialization.

An interface in the blocking state performs these functions:

- Discards frames received on the interface
- Discards frames switched from another interface for forwarding
- Does not learn addresses
- Receives BPDUs

Listening State

The listening state is the first state a Layer 2 interface enters after the blocking state. The interface enters this state when the spanning tree decides that the interface should participate in frame forwarding.

An interface in the listening state performs these functions:

- Discards frames received on the interface
- Discards frames switched from another interface for forwarding
- Does not learn addresses
- Receives BPDUs

Learning State

A Layer 2 interface in the learning state prepares to participate in frame forwarding. The interface enters the learning state from the listening state.

An interface in the learning state performs these functions:

- Discards frames received on the interface
- Discards frames switched from another interface for forwarding
- Learns addresses
- Receives BPDUs

Forwarding State

A Layer 2 interface in the forwarding state forwards frames. The interface enters the forwarding state from the learning state.

An interface in the forwarding state performs these functions:

- Receives and forwards frames received on the interface
- Forwards frames switched from another interface
- Learns addresses
- Receives BPDUs

Disabled State

A Layer 2 interface in the disabled state does not participate in frame forwarding or in the spanning tree. An interface in the disabled state is nonoperational.

A disabled interface performs these functions:

- Discards frames received on the interface
- Discards frames switched from another interface for forwarding
- Does not learn addresses
- Does not receive BPDUs

How a Switch or Port Becomes the Root Switch or Root Port

If all switches in a network are enabled with default spanning-tree settings, the switch with the lowest MAC address becomes the root switch. In [Figure 15-2](#), Switch A is elected as the root switch because the switch priority of all the switches is set to the default (32768) and Switch A has the lowest MAC address. However, because of traffic patterns, number of forwarding interfaces, or link types, Switch A might not be the ideal root switch. By increasing the priority (lowering the numerical value) of the ideal switch so that it becomes the root switch, you force a spanning-tree recalculation to form a new topology with the ideal switch as the root.

Figure 15-2 Spanning-Tree Topology

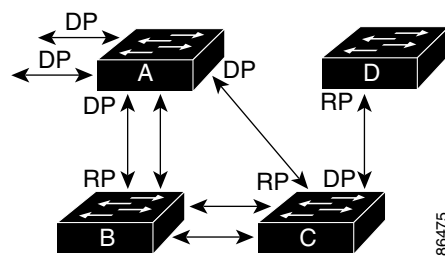

RP = Root Port
DP = Designated Port

When the spanning-tree topology is calculated based on default parameters, the path between source and destination end stations in a switched network might not be ideal. For instance, connecting higher-speed links to an interface that has a higher number than the root port can cause a root-port change. The goal is to make the fastest link the root port.

For example, assume that one port on Switch B is a Gigabit Ethernet link and that another port on Switch B (a 10/100 link) is the root port. Network traffic might be more efficient over the Gigabit Ethernet link. By changing the spanning-tree port priority on the Gigabit Ethernet port to a higher priority (lower numerical value) than the root port, the Gigabit Ethernet port becomes the new root port.

Spanning Tree and Redundant Connectivity

You can create a redundant backbone with spanning tree by connecting two switch interfaces to another device or to two different devices, as shown in [Figure 15-3](#). Spanning tree automatically disables one interface but enables it if the other one fails. If one link is high-speed and the other is low-speed, the low-speed link is always disabled. If the speeds are the same, the port priority and port ID are added together, and spanning tree disables the link with the lowest value.

Figure 15-3 Spanning Tree and Redundant Connectivity

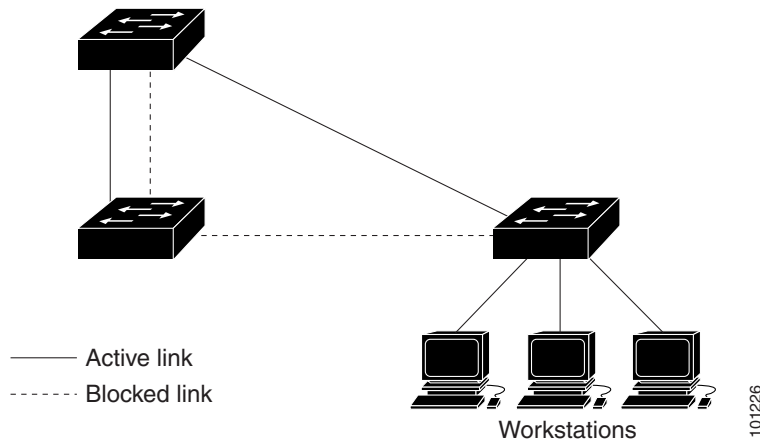

You can also create redundant links between switches by using EtherChannel groups. For more information, see [Chapter 31, “Configuring EtherChannels and Link-State Tracking.”](#)

Spanning-Tree Address Management

IEEE 802.1D specifies 17 multicast addresses, ranging from 0x00180C2000000 to 0x0180C2000010, to be used by different bridge protocols. These addresses are static addresses that cannot be removed.

Regardless of the spanning-tree state, each switch receives but does not forward packets destined for addresses between 0x0180C2000000 and 0x0180C200000F.

If spanning tree is enabled, the CPU on the switch receives packets destined for 0x0180C2000000 and 0x0180C2000010. If spanning tree is disabled, the switch forwards those packets as unknown multicast addresses.

Accelerated Aging to Retain Connectivity

The default for aging dynamic addresses is 5 minutes, the default setting of the **mac address-table aging-time** global configuration command. However, a spanning-tree reconfiguration can cause many station locations to change. Because these stations could be unreachable for 5 minutes or more during a reconfiguration, the address-aging time is accelerated so that station addresses can be dropped from the address table and then relearned. The accelerated aging is the same as the forward-delay parameter value (**spanning-tree vlan *vlan-id* forward-time seconds** global configuration command) when the spanning tree reconfigures.

Because each VLAN is a separate spanning-tree instance, the switch accelerates aging on a per-VLAN basis. A spanning-tree reconfiguration on one VLAN can cause the dynamic addresses learned on that VLAN to be subject to accelerated aging. Dynamic addresses on other VLANs can be unaffected and remain subject to the aging interval entered for the switch.

Spanning-Tree Modes and Protocols

The switch supports these spanning-tree modes and protocols:

- **PVST+**—This spanning-tree mode is based on the IEEE 802.1D standard and Cisco proprietary extensions. It is the default spanning-tree mode used on all Ethernet port-based VLANs. The PVST+ runs on each VLAN on the switch up to the maximum supported, ensuring that each has a loop-free path through the network.

The PVST+ provides Layer 2 load balancing for the VLAN on which it runs. You can create different logical topologies by using the VLANs on your network to ensure that all of your links are used but that no one link is oversubscribed. Each instance of PVST+ on a VLAN has a single root switch. This root switch propagates the spanning-tree information associated with that VLAN to all other switches in the network. Because each switch has the same information about the network, this process ensures that the network topology is maintained.

- **Rapid PVST+**—This spanning-tree mode is the same as PVST+ except that it uses a rapid convergence based on the IEEE 802.1w standard. To provide rapid convergence, the rapid PVST+ immediately deletes dynamically learned MAC address entries on a per-port basis upon receiving a topology change. By contrast, PVST+ uses a short aging time for dynamically learned MAC address entries.

The rapid PVST+ uses the same configuration as PVST+ (except where noted), and the switch needs only minimal extra configuration. The benefit of rapid PVST+ is that you can migrate a large PVST+ install base to rapid PVST+ without having to learn the complexities of the MSTP configuration and without having to re provision your network. In rapid-PVST+ mode, each VLAN runs its own spanning-tree instance up to the maximum supported.

- **MSTP**—This spanning-tree mode is based on the IEEE 802.1s standard. You can map multiple VLANs to the same spanning-tree instance, which reduces the number of spanning-tree instances required to support a large number of VLANs. The MSTP runs on top of the RSTP (based on IEEE 802.1w), which provides for rapid convergence of the spanning tree by eliminating the forward delay and by quickly transitioning root ports and designated ports to the forwarding state. You cannot run MSTP without RSTP.

The most common initial deployment of MSTP is in the backbone and distribution layers of a Layer 2 switched network. For more information, see [Chapter 16, “Configuring MSTP.”](#)

For information about the number of supported spanning-tree instances, see the next section.

Supported Spanning-Tree Instances

In PVST+ or rapid-PVST+ mode, the switch supports up to 128 spanning-tree instances.

In MSTP mode, the switch supports up to 65 MST instances. The number of VLANs that can be mapped to a particular MST instance is unlimited.

For information about how spanning tree interoperates with the VLAN Trunking Protocol (VTP), see the [“Spanning-Tree Configuration Guidelines”](#) section on page 15-12.

Spanning-Tree Interoperability and Backward Compatibility

Table 15-2 lists the interoperability and compatibility among the supported spanning-tree modes in a network.

Table 15-2 PVST+, MSTP, and Rapid-PVST+ Interoperability

	PVST+	MSTP	Rapid PVST+
PVST+	Yes	Yes (with restrictions)	Yes (reverts to PVST+)
MSTP	Yes (with restrictions)	Yes	Yes (reverts to PVST+)
Rapid PVST+	Yes (reverts to PVST+)	Yes (reverts to PVST+)	Yes

In a mixed MSTP and PVST+ network, the common spanning-tree (CST) root must be inside the MST backbone, and a PVST+ switch cannot connect to multiple MST regions.

When a network contains switches running rapid PVST+ and switches running PVST+, we recommend that the rapid-PVST+ switches and PVST+ switches be configured for different spanning-tree instances. In the rapid-PVST+ spanning-tree instances, the root switch must be a rapid-PVST+ switch. In the PVST+ instances, the root switch must be a PVST+ switch. The PVST+ switches should be at the edge of the network.

STP and IEEE 802.1Q Trunks

The IEEE 802.1Q standard for VLAN trunks imposes some limitations on the spanning-tree strategy for a network. The standard requires only one spanning-tree instance for *all* VLANs allowed on the trunks. However, in a network of Cisco switches connected through IEEE 802.1Q trunks, the switches maintain one spanning-tree instance for *each* VLAN allowed on the trunks.

When you connect a Cisco switch to a non-Cisco device through an IEEE 802.1Q trunk, the Cisco switch uses PVST+ to provide spanning-tree interoperability. If rapid PVST+ is enabled, the switch uses it instead of PVST+. The switch combines the spanning-tree instance of the IEEE 802.1Q VLAN of the trunk with the spanning-tree instance of the non-Cisco IEEE 802.1Q switch.

However, all PVST+ or rapid-PVST+ information is maintained by Cisco switches separated by a cloud of non-Cisco IEEE 802.1Q switches. The non-Cisco IEEE 802.1Q cloud separating the Cisco switches is treated as a single trunk link between the switches.

PVST+ is automatically enabled on IEEE 802.1Q trunks, and no user configuration is required. The external spanning-tree behavior on access ports and Inter-Switch Link (ISL) trunk ports is not affected by PVST+.

For more information on IEEE 802.1Q trunks, see [Chapter 12, “Configuring VLANs.”](#)

Configuring Spanning-Tree Features

These sections contain this configuration information:

- [Default Spanning-Tree Configuration, page 15-11](#)
- [Spanning-Tree Configuration Guidelines, page 15-12](#)
- [Changing the Spanning-Tree Mode., page 15-13 \(required\)](#)

- [Disabling Spanning Tree, page 15-14](#) (optional)
- [Configuring the Root Switch, page 15-14](#) (optional)
- [Configuring a Secondary Root Switch, page 15-16](#) (optional)
- [Configuring Port Priority, page 15-16](#) (optional)
- [Configuring Path Cost, page 15-18](#) (optional)
- [Configuring the Switch Priority of a VLAN, page 15-19](#) (optional)
- [Configuring Spanning-Tree Timers, page 15-20](#) (optional)

Default Spanning-Tree Configuration

Table 15-3 shows the default spanning-tree configuration.

Table 15-3 *Default Spanning-Tree Configuration*

Feature	Default Setting
Enable state	Enabled on VLAN 1. For more information, see the “Supported Spanning-Tree Instances” section on page 15-9.
Spanning-tree mode	PVST+. (Rapid PVST+ and MSTP are disabled.)
Switch priority	32768.
Spanning-tree port priority (configurable on a per-interface basis)	128.
Spanning-tree port cost (configurable on a per-interface basis)	1000 Mb/s: 4. 100 Mb/s: 19. 10 Mb/s: 100.
Spanning-tree VLAN port priority (configurable on a per-VLAN basis)	128.
Spanning-tree VLAN port cost (configurable on a per-VLAN basis)	1000 Mb/s: 4. 100 Mb/s: 19. 10 Mb/s: 100.
Spanning-tree timers	Hello time: 2 seconds. Forward-delay time: 15 seconds. Maximum-aging time: 20 seconds. Transmit hold count: 6 BPDUs

Spanning-Tree Configuration Guidelines

If more VLANs are defined in the VTP than there are spanning-tree instances, you can enable PVST+ or rapid PVST+ on only 128 VLANs on the switch. The remaining VLANs operate with spanning tree disabled. However, you can map multiple VLANs to the same spanning-tree instances by using MSTP. For more information, see [Chapter 16, “Configuring MSTP.”](#)

If 128 instances of spanning tree are already in use, you can disable spanning tree on one of the VLANs and then enable it on the VLAN where you want it to run. Use the **no spanning-tree vlan *vlan-id*** global configuration command to disable spanning tree on a specific VLAN, and use the **spanning-tree vlan *vlan-id*** global configuration command to enable spanning tree on the desired VLAN.



Caution

Switches that are not running spanning tree still forward BPDUs that they receive so that the other switches on the VLAN that have a running spanning-tree instance can break loops. Therefore, spanning tree must be running on enough switches to break all the loops in the network; for example, at least one switch on each loop in the VLAN must be running spanning tree. It is not absolutely necessary to run spanning tree on all switches in the VLAN. However, if you are running spanning tree only on a minimal set of switches, an incautious change to the network that introduces another loop into the VLAN can result in a broadcast storm.



Note

If you have already used all available spanning-tree instances on your switch, adding another VLAN anywhere in the VTP domain creates a VLAN that is not running spanning tree on that switch. If you have the default allowed list on the trunk ports of that switch, the new VLAN is carried on all trunk ports. Depending on the topology of the network, this could create a loop in the new VLAN that will not be broken, particularly if there are several adjacent switches that have all run out of spanning-tree instances. You can prevent this possibility by setting up allowed lists on the trunk ports of switches that have used up their allocation of spanning-tree instances. Setting up allowed lists is not necessary in many cases and can make it more labor-intensive to add another VLAN to the network.

Spanning-tree commands control the configuration of VLAN spanning-tree instances. You create a spanning-tree instance when you assign an interface to a VLAN. The spanning-tree instance is removed when the last interface is moved to another VLAN. You can configure switch and port parameters before a spanning-tree instance is created; these parameters are applied when the spanning-tree instance is created.

The switch supports PVST+, rapid PVST+, and MSTP, but only one version can be active at any time. (For example, all VLANs run PVST+, all VLANs run rapid PVST+, or all VLANs run MSTP.) For information about the different spanning-tree modes and how they interoperate, see the [“Spanning-Tree Interoperability and Backward Compatibility”](#) section on page 15-10.

For configuration guidelines about UplinkFast and BackboneFast, see the [“Optional Spanning-Tree Configuration Guidelines”](#) section on page 17-10.



Caution

Loop guard works only on point-to-point links. We recommend that each end of the link has a directly connected device that is running STP.

Changing the Spanning-Tree Mode.

The switch supports three spanning-tree modes: PVST+, rapid PVST+, or MSTP. By default, the switch runs the PVST+ protocol.

Beginning in privileged EXEC mode, follow these steps to change the spanning-tree mode. If you want to enable a mode that is different from the default mode, this procedure is required.

	Command	Purpose
Step 1	configure terminal	Enter global configuration mode.
Step 2	spanning-tree mode {pvst mst rapid-pvst}	Configure a spanning-tree mode. <ul style="list-style-type: none"> • Select pvst to enable PVST+ (the default setting). • Select mst to enable MSTP (and RSTP). For more configuration steps, see Chapter 16, “Configuring MSTP.” • Select rapid-pvst to enable rapid PVST+.
Step 3	interface interface-id	(Recommended for rapid-PVST+ mode only) Specify an interface to configure, and enter interface configuration mode. Valid interfaces include physical ports, VLANs, and port channels. The VLAN ID range is 1 to 4094. The port-channel range is 1 to 6.
Step 4	spanning-tree link-type point-to-point	(Recommended for rapid-PVST+ mode only) Specify that the link type for this port is point-to-point. If you connect this port (local port) to a remote port through a point-to-point link and the local port becomes a designated port, the switch negotiates with the remote port and rapidly changes the local port to the forwarding state.
Step 5	end	Return to privileged EXEC mode.
Step 6	clear spanning-tree detected-protocols	(Recommended for rapid-PVST+ mode only) If any port on the switch is connected to a port on a legacy IEEE 802.1D switch, restart the protocol migration process on the entire switch. This step is optional if the designated switch detects that this switch is running rapid PVST+.
Step 7	show spanning-tree summary and show spanning-tree interface interface-id	Verify your entries.
Step 8	copy running-config startup-config	(Optional) Save your entries in the configuration file.

To return to the default setting, use the **no spanning-tree mode** global configuration command. To return the port to its default setting, use the **no spanning-tree link-type** interface configuration command.

Disabling Spanning Tree

Spanning tree is enabled by default on VLAN 1 and on all newly created VLANs up to the spanning-tree limit specified in the “[Supported Spanning-Tree Instances](#)” section on page 15-9. Disable spanning tree only if you are sure there are no loops in the network topology.



Caution

When spanning tree is disabled and loops are present in the topology, excessive traffic and indefinite packet duplication can drastically reduce network performance.

Beginning in privileged EXEC mode, follow these steps to disable spanning-tree on a per-VLAN basis. This procedure is optional.

	Command	Purpose
Step 1	configure terminal	Enter global configuration mode.
Step 2	no spanning-tree vlan <i>vlan-id</i>	For <i>vlan-id</i> , the range is 1 to 4094.
Step 3	end	Return to privileged EXEC mode.
Step 4	show spanning-tree vlan <i>vlan-id</i>	Verify your entries.
Step 5	copy running-config startup-config	(Optional) Save your entries in the configuration file.

To re-enable spanning-tree, use the **spanning-tree vlan** *vlan-id* global configuration command.

Configuring the Root Switch

The switch maintains a separate spanning-tree instance for each active VLAN configured on it. A bridge ID, consisting of the switch priority and the switch MAC address, is associated with each instance. For each VLAN, the switch with the lowest bridge ID becomes the root switch for that VLAN.

To configure a switch to become the root for the specified VLAN, use the **spanning-tree vlan** *vlan-id* **root** global configuration command to modify the switch priority from the default value (32768) to a significantly lower value. When you enter this command, the software checks the switch priority of the root switches for each VLAN. Because of the extended system ID support, the switch sets its own priority for the specified VLAN to 24576 if this value will cause this switch to become the root for the specified VLAN.

If any root switch for the specified VLAN has a switch priority lower than 24576, the switch sets its own priority for the specified VLAN to 4096 less than the lowest switch priority. (4096 is the value of the least-significant bit of a 4-bit switch priority value as shown in [Table 15-1 on page 15-4](#).)



Note

The **spanning-tree vlan** *vlan-id* **root** global configuration command fails if the value necessary to be the root switch is less than 1.



Note

If your network consists of switches that both do and do not support the extended system ID, it is unlikely that the switch with the extended system ID support will become the root switch. The extended system ID increases the switch priority value every time the VLAN number is greater than the priority of the connected switches running older software.

**Note**

The root switch for each spanning-tree instance should be a backbone or distribution switch. Do not configure an access switch as the spanning-tree primary root.

Use the **diameter** keyword to specify the Layer 2 network diameter (that is, the maximum number of switch hops between any two end stations in the Layer 2 network). When you specify the network diameter, the switch automatically sets an optimal hello time, forward-delay time, and maximum-age time for a network of that diameter, which can significantly reduce the convergence time. You can use the **hello** keyword to override the automatically calculated hello time.

**Note**

After configuring the switch as the root switch, we recommend that you avoid manually configuring the hello time, forward-delay time, and maximum-age time through the **spanning-tree vlan *vlan-id* hello-time**, **spanning-tree vlan *vlan-id* forward-time**, and the **spanning-tree vlan *vlan-id* max-age** global configuration commands.

Beginning in privileged EXEC mode, follow these steps to configure a switch to become the root for the specified VLAN. This procedure is optional.

	Command	Purpose
Step 1	configure terminal	Enter global configuration mode.
Step 2	spanning-tree vlan <i>vlan-id</i> root primary [diameter <i>net-diameter</i> [hello-time <i>seconds</i>]]	Configure a switch to become the root for the specified VLAN. <ul style="list-style-type: none"> For <i>vlan-id</i>, you can specify a single VLAN identified by VLAN ID number, a range of VLANs separated by a hyphen, or a series of VLANs separated by a comma. The range is 1 to 4094. (Optional) For diameter <i>net-diameter</i>, specify the maximum number of switches between any two end stations. The range is 2 to 7. (Optional) For hello-time <i>seconds</i>, specify the interval in seconds between the generation of configuration messages by the root switch. The range is 1 to 10; the default is 2.
Step 3	end	Return to privileged EXEC mode.
Step 4	show spanning-tree detail	Verify your entries.
Step 5	copy running-config startup-config	(Optional) Save your entries in the configuration file.

To return to the default setting, use the **no spanning-tree vlan *vlan-id* root** global configuration command.

Configuring a Secondary Root Switch

When you configure a switch as the secondary root, the switch priority is modified from the default value (32768) to 28672. The switch is then likely to become the root switch for the specified VLAN if the primary root switch fails. This is assuming that the other network switches use the default switch priority of 32768 and therefore are unlikely to become the root switch.

You can execute this command on more than one switch to configure multiple backup root switches. Use the same network diameter and hello-time values that you used when you configured the primary root switch with the **spanning-tree vlan *vlan-id* root primary** global configuration command.

Beginning in privileged EXEC mode, follow these steps to configure a switch to become the secondary root for the specified VLAN. This procedure is optional.

	Command	Purpose
Step 1	configure terminal	Enter global configuration mode.
Step 2	spanning-tree vlan <i>vlan-id</i> root secondary [diameter <i>net-diameter</i> [hello-time <i>seconds</i>]]	Configure a switch to become the secondary root for the specified VLAN. <ul style="list-style-type: none"> For <i>vlan-id</i>, you can specify a single VLAN identified by VLAN ID number, a range of VLANs separated by a hyphen, or a series of VLANs separated by a comma. The range is 1 to 4094. (Optional) For diameter <i>net-diameter</i>, specify the maximum number of switches between any two end stations. The range is 2 to 7. (Optional) For hello-time <i>seconds</i>, specify the interval in seconds between the generation of configuration messages by the root switch. The range is 1 to 10; the default is 2. Use the same network diameter and hello-time values that you used when configuring the primary root switch. See the “Configuring the Root Switch” section on page 15-14 .
Step 3	end	Return to privileged EXEC mode.
Step 4	show spanning-tree detail	Verify your entries.
Step 5	copy running-config startup-config	(Optional) Save your entries in the configuration file.

To return to the default setting, use the **no spanning-tree vlan *vlan-id* root** global configuration command.

Configuring Port Priority

If a loop occurs, spanning tree uses the port priority when selecting an interface to put into the forwarding state. You can assign higher priority values (lower numerical values) to interfaces that you want selected first and lower priority values (higher numerical values) that you want selected last. If all interfaces have the same priority value, spanning tree puts the interface with the lowest interface number in the forwarding state and blocks the other interfaces.

Beginning in privileged EXEC mode, follow these steps to configure the port priority of an interface. This procedure is optional.

	Command	Purpose
Step 1	configure terminal	Enter global configuration mode.
Step 2	interface <i>interface-id</i>	Specify an interface to configure, and enter interface configuration mode. Valid interfaces include physical ports and port-channel logical interfaces (port-channel <i>port-channel-number</i>).
Step 3	spanning-tree port-priority <i>priority</i>	Configure the port priority for an interface. For <i>priority</i> , the range is 0 to 240, in increments of 16; the default is 128. Valid values are 0, 16, 32, 48, 64, 80, 96, 112, 128, 144, 160, 176, 192, 208, 224, and 240. All other values are rejected. The lower the number, the higher the priority.
Step 4	spanning-tree vlan <i>vlan-id</i> port-priority <i>priority</i>	Configure the port priority for a VLAN. <ul style="list-style-type: none"> For <i>vlan-id</i>, you can specify a single VLAN identified by VLAN ID number, a range of VLANs separated by a hyphen, or a series of VLANs separated by a comma. The range is 1 to 4094. For <i>priority</i>, the range is 0 to 240, in increments of 16; the default is 128. Valid values are 0, 16, 32, 48, 64, 80, 96, 112, 128, 144, 160, 176, 192, 208, 224, and 240. All other values are rejected. The lower the number, the higher the priority.
Step 5	end	Return to privileged EXEC mode.
Step 6	show spanning-tree interface <i>interface-id</i> or show spanning-tree vlan <i>vlan-id</i>	Verify your entries.
Step 7	copy running-config startup-config	(Optional) Save your entries in the configuration file.

**Note**

The **show spanning-tree interface** *interface-id* privileged EXEC command displays information only if the port is in a link-up operative state. Otherwise, you can use the **show running-config interface** privileged EXEC command to confirm the configuration.

To return to the default setting, use the **no spanning-tree [vlan *vlan-id*] port-priority** interface configuration command. For information on how to configure load sharing on trunk ports by using spanning-tree port priorities, see the [“Configuring Trunk Ports for Load Sharing”](#) section on page 12-20.

Configuring Path Cost

The spanning-tree path cost default value is derived from the media speed of an interface. If a loop occurs, spanning tree uses cost when selecting an interface to put in the forwarding state. You can assign lower cost values to interfaces that you want selected first and higher cost values that you want selected last. If all interfaces have the same cost value, spanning tree puts the interface with the lowest interface number in the forwarding state and blocks the other interfaces.

Beginning in privileged EXEC mode, follow these steps to configure the cost of an interface. This procedure is optional.

	Command	Purpose
Step 1	configure terminal	Enter global configuration mode.
Step 2	interface <i>interface-id</i>	Specify an interface to configure, and enter interface configuration mode. Valid interfaces include physical ports and port-channel logical interfaces (port-channel <i>port-channel-number</i>).
Step 3	spanning-tree cost <i>cost</i>	Configure the cost for an interface. If a loop occurs, spanning tree uses the path cost when selecting an interface to place into the forwarding state. A lower path cost represents higher-speed transmission. For <i>cost</i> , the range is 1 to 200000000; the default value is derived from the media speed of the interface.
Step 4	spanning-tree vlan <i>vlan-id</i> cost <i>cost</i>	Configure the cost for a VLAN. If a loop occurs, spanning tree uses the path cost when selecting an interface to place into the forwarding state. A lower path cost represents higher-speed transmission. <ul style="list-style-type: none"> For <i>vlan-id</i>, you can specify a single VLAN identified by VLAN ID number, a range of VLANs separated by a hyphen, or a series of VLANs separated by a comma. The range is 1 to 4094. For <i>cost</i>, the range is 1 to 200000000; the default value is derived from the media speed of the interface.
Step 5	end	Return to privileged EXEC mode.
Step 6	show spanning-tree interface <i>interface-id</i> or show spanning-tree vlan <i>vlan-id</i>	Verify your entries.
Step 7	copy running-config startup-config	(Optional) Save your entries in the configuration file.



Note

The **show spanning-tree interface** *interface-id* privileged EXEC command displays information only for ports that are in a link-up operative state. Otherwise, you can use the **show running-config** privileged EXEC command to confirm the configuration.

To return to the default setting, use the **no spanning-tree [vlan *vlan-id*] cost** interface configuration command. For information on how to configure load sharing on trunk ports by using spanning-tree path costs, see the “[Configuring Trunk Ports for Load Sharing](#)” section on page 12-20.

Configuring the Switch Priority of a VLAN

You can configure the switch priority and make it more likely that the switch will be chosen as the root switch.



Note

Exercise care when using this command. For most situations, we recommend that you use the **spanning-tree vlan *vlan-id* root primary** and the **spanning-tree vlan *vlan-id* root secondary** global configuration commands to modify the switch priority.

Beginning in privileged EXEC mode, follow these steps to configure the switch priority of a VLAN. This procedure is optional.

	Command	Purpose
Step 1	configure terminal	Enter global configuration mode.
Step 2	spanning-tree vlan <i>vlan-id</i> priority <i>priority</i>	Configure the switch priority of a VLAN. <ul style="list-style-type: none"> For <i>vlan-id</i>, you can specify a single VLAN identified by VLAN ID number, a range of VLANs separated by a hyphen, or a series of VLANs separated by a comma. The range is 1 to 4094. For <i>priority</i>, the range is 0 to 61440 in increments of 4096; the default is 32768. The lower the number, the more likely the switch will be chosen as the root switch. Valid priority values are 4096, 8192, 12288, 16384, 20480, 24576, 28672, 32768, 36864, 40960, 45056, 49152, 53248, 57344, and 61440. All other values are rejected.
Step 3	end	Return to privileged EXEC mode.
Step 4	show spanning-tree vlan <i>vlan-id</i>	Verify your entries.
Step 5	copy running-config startup-config	(Optional) Save your entries in the configuration file.

To return to the default setting, use the **no spanning-tree vlan *vlan-id* priority** global configuration command.

Configuring Spanning-Tree Timers

Table 15-4 describes the timers that affect the entire spanning-tree performance.

Table 15-4 Spanning-Tree Timers

Variable	Description
Hello timer	Controls how often the switch broadcasts hello messages to other switches.
Forward-delay timer	Controls how long each of the listening and learning states last before the interface begins forwarding.
Maximum-age timer	Controls the amount of time the switch stores protocol information received on an interface.
Transmit hold count	Controls the number of BPDUs that can be sent before pausing for 1 second.

The sections that follow provide the configuration steps.

Configuring the Hello Time

You can configure the interval between the generation of configuration messages by the root switch by changing the hello time.



Note

Exercise care when using this command. For most situations, we recommend that you use the **spanning-tree vlan *vlan-id* root primary** and the **spanning-tree vlan *vlan-id* root secondary** global configuration commands to modify the hello time.

Beginning in privileged EXEC mode, follow these steps to configure the hello time of a VLAN. This procedure is optional.

	Command	Purpose
Step 1	configure terminal	Enter global configuration mode.
Step 2	spanning-tree vlan <i>vlan-id</i> hello-time <i>seconds</i>	Configure the hello time of a VLAN. The hello time is the interval between the generation of configuration messages by the root switch. These messages mean that the switch is alive. <ul style="list-style-type: none"> For <i>vlan-id</i>, you can specify a single VLAN identified by VLAN ID number, a range of VLANs separated by a hyphen, or a series of VLANs separated by a comma. The range is 1 to 4094. For <i>seconds</i>, the range is 1 to 10; the default is 2.
Step 3	end	Return to privileged EXEC mode.
Step 4	show spanning-tree vlan <i>vlan-id</i>	Verify your entries.
Step 5	copy running-config startup-config	(Optional) Save your entries in the configuration file.

To return to the default setting, use the **no spanning-tree vlan *vlan-id* hello-time** global configuration command.

Configuring the Forwarding-Delay Time for a VLAN

Beginning in privileged EXEC mode, follow these steps to configure the forwarding-delay time for a VLAN. This procedure is optional.

	Command	Purpose
Step 1	configure terminal	Enter global configuration mode.
Step 2	spanning-tree vlan <i>vlan-id</i> forward-time <i>seconds</i>	Configure the forward time of a VLAN. The forward delay is the number of seconds an interface waits before changing from its spanning-tree learning and listening states to the forwarding state. <ul style="list-style-type: none"> For <i>vlan-id</i>, you can specify a single VLAN identified by VLAN ID number, a range of VLANs separated by a hyphen, or a series of VLANs separated by a comma. The range is 1 to 4094. For <i>seconds</i>, the range is 4 to 30; the default is 15.
Step 3	end	Return to privileged EXEC mode.
Step 4	show spanning-tree vlan <i>vlan-id</i>	Verify your entries.
Step 5	copy running-config startup-config	(Optional) Save your entries in the configuration file.

To return to the default setting, use the **no spanning-tree vlan *vlan-id* forward-time** global configuration command.

Configuring the Maximum-Aging Time for a VLAN

Beginning in privileged EXEC mode, follow these steps to configure the maximum-aging time for a VLAN. This procedure is optional.

	Command	Purpose
Step 1	configure terminal	Enter global configuration mode.
Step 2	spanning-tree vlan <i>vlan-id</i> max-age <i>seconds</i>	Configure the maximum-aging time of a VLAN. The maximum-aging time is the number of seconds a switch waits without receiving spanning-tree configuration messages before attempting a reconfiguration. <ul style="list-style-type: none"> For <i>vlan-id</i>, you can specify a single VLAN identified by VLAN ID number, a range of VLANs separated by a hyphen, or a series of VLANs separated by a comma. The range is 1 to 4094. For <i>seconds</i>, the range is 6 to 40; the default is 20.
Step 3	end	Return to privileged EXEC mode.
Step 4	show spanning-tree vlan <i>vlan-id</i>	Verify your entries.
Step 5	copy running-config startup-config	(Optional) Save your entries in the configuration file.

To return to the default setting, use the **no spanning-tree vlan *vlan-id* max-age** global configuration command.

Configuring the Transmit Hold-Count

You can configure the BPDU burst size by changing the transmit hold count value.



Note

Changing this parameter to a higher value can have a significant impact on CPU utilization, especially in Rapid-PVST mode. Lowering this value can slow down convergence in certain scenarios. We recommend that you maintain the default setting.

Beginning in privileged EXEC mode, follow these steps to configure the transmit hold-count. This procedure is optional.

	Command	Purpose
Step 1	configure terminal	Enter global configuration mode.
Step 2	spanning-tree transmit hold-count <i>value</i>	Configure the number of BPDUs that can be sent before pausing for 1 second. For <i>value</i> , the range is 1 to 20; the default is 6.
Step 3	end	Return to privileged EXEC mode.
Step 4	show spanning-tree detail	Verify your entries.
Step 5	copy running-config startup-config	(Optional) Save your entries in the configuration file.

To return to the default setting, use the **no spanning-tree transmit hold-count** *value* global configuration command.

Displaying the Spanning-Tree Status

To display the spanning-tree status, use one or more of the privileged EXEC commands in [Table 15-5](#):

Table 15-5 **Commands for Displaying Spanning-Tree Status**

Command	Purpose
show spanning-tree active	Displays spanning-tree information on active interfaces only.
show spanning-tree detail	Displays a detailed summary of interface information.
show spanning-tree interface <i>interface-id</i>	Displays spanning-tree information for the specified interface.
show spanning-tree summary [totals]	Displays a summary of interface states or displays the total lines of the STP state section.

You can clear spanning-tree counters by using the **clear spanning-tree** [**interface** *interface-id*] privileged EXEC command.

For information about other keywords for the **show spanning-tree** privileged EXEC command, see the command reference for this release.



CHAPTER 16

Configuring MSTP

This chapter describes how to configure the Cisco implementation of the IEEE 802.1s Multiple STP (MSTP) on the Catalyst 2960 switch.



Note

The multiple spanning-tree (MST) implementation in Cisco IOS Release 12.2(25)SED is based on the IEEE 802.1s standard. The MST implementations in earlier Cisco IOS releases are prestandard.

The MSTP enables multiple VLANs to be mapped to the same spanning-tree instance, reducing the number of spanning-tree instances needed to support a large number of VLANs. The MSTP provides for multiple forwarding paths for data traffic and enables load balancing. It improves the fault tolerance of the network because a failure in one instance (forwarding path) does not affect other instances (forwarding paths). The most common initial deployment of MSTP is in the backbone and distribution layers of a Layer 2 switched network. This deployment provides the highly available network required in a service-provider environment.

When the switch is in the MST mode, the Rapid Spanning Tree Protocol (RSTP), which is based on IEEE 802.1w, is automatically enabled. The RSTP provides rapid convergence of the spanning tree through explicit handshaking that eliminates the IEEE 802.1D forwarding delay and quickly transitions root ports and designated ports to the forwarding state.

Both MSTP and RSTP improve the spanning-tree operation and maintain backward compatibility with equipment that is based on the (original) IEEE 802.1D spanning tree, with existing Cisco-proprietary Multiple Instance STP (MISTP), and with existing Cisco per-VLAN spanning-tree plus (PVST+) and rapid per-VLAN spanning-tree plus (rapid PVST+). For information about PVST+ and rapid PVST+, see [Chapter 15, “Configuring STP.”](#) For information about other spanning-tree features such as Port Fast, UplinkFast, root guard, and so forth, see [Chapter 17, “Configuring Optional Spanning-Tree Features.”](#)



Note

For complete syntax and usage information for the commands used in this chapter, see the command reference for this release.

This chapter consists of these sections:

- [Understanding MSTP, page 16-2](#)
- [Understanding RSTP, page 16-8](#)
- [Configuring MSTP Features, page 16-14](#)
- [Displaying the MST Configuration and Status, page 16-26](#)

Understanding MSTP

MSTP, which uses RSTP for rapid convergence, enables VLANs to be grouped into a spanning-tree instance, with each instance having a spanning-tree topology independent of other spanning-tree instances. This architecture provides multiple forwarding paths for data traffic, enables load balancing, and reduces the number of spanning-tree instances required to support a large number of VLANs.

These sections describe how the MSTP works:

- [Multiple Spanning-Tree Regions, page 16-2](#)
- [IST, CIST, and CST, page 16-3](#)
- [Hop Count, page 16-5](#)
- [Boundary Ports, page 16-6](#)
- [IEEE 802.1s Implementation, page 16-6](#)
- [Interoperability with IEEE 802.1D STP, page 16-8](#)

For configuration information, see the “Configuring MSTP Features” section on page 16-14.

Multiple Spanning-Tree Regions

For switches to participate in multiple spanning-tree (MST) instances, you must consistently configure the switches with the same MST configuration information. A collection of interconnected switches that have the same MST configuration comprises an MST region as shown in [Figure 16-1 on page 16-4](#).

The MST configuration controls to which MST region each switch belongs. The configuration includes the name of the region, the revision number, and the MST VLAN-to-instance assignment map. You configure the switch for a region by using the **spanning-tree mst configuration** global configuration command, after which the switch enters the MST configuration mode. From this mode, you can map VLANs to an MST instance by using the **instance** MST configuration command, specify the region name by using the **name** MST configuration command, and set the revision number by using the **revision** MST configuration command.

A region can have one or multiple members with the same MST configuration. Each member must be capable of processing RSTP bridge protocol data units (BPDUs). There is no limit to the number of MST regions in a network, but each region can support up to 65 spanning-tree instances. Instances can be identified by any number in the range from 0 to 4094. You can assign a VLAN to only one spanning-tree instance at a time.

IST, CIST, and CST

Unlike PVST+ and rapid PVST+ in which all the spanning-tree instances are independent, the MSTP establishes and maintains two types of spanning trees:

- An internal spanning tree (IST), which is the spanning tree that runs in an MST region.

Within each MST region, the MSTP maintains multiple spanning-tree instances. Instance 0 is a special instance for a region, known as the internal spanning tree (IST). All other MST instances are numbered from 1 to 4094.

The IST is the only spanning-tree instance that sends and receives BPDUs. All of the other spanning-tree instance information is contained in M-records, which are encapsulated within MSTP BPDUs. Because the MSTP BPDU carries information for all instances, the number of BPDUs that need to be processed to support multiple spanning-tree instances is significantly reduced.

All MST instances within the same region share the same protocol timers, but each MST instance has its own topology parameters, such as root switch ID, root path cost, and so forth. By default, all VLANs are assigned to the IST.

An MST instance is local to the region; for example, MST instance 1 in region A is independent of MST instance 1 in region B, even if regions A and B are interconnected.

- A common and internal spanning tree (CIST), which is a collection of the ISTs in each MST region, and the common spanning tree (CST) that interconnects the MST regions and single spanning trees.

The spanning tree computed in a region appears as a subtree in the CST that encompasses the entire switched domain. The CIST is formed by the spanning-tree algorithm running among switches that support the IEEE 802.1w, IEEE 802.1s, and IEEE 802.1D standards. The CIST inside an MST region is the same as the CST outside a region.

For more information, see the “Operations Within an MST Region” section on page 16-3 and the “Operations Between MST Regions” section on page 16-4.

**Note**

The implementation of the IEEE 802.1s standard, changes some of the terminology associated with MST implementations. For a summary of these changes, see [Table 15-1 on page 15-4](#).

Operations Within an MST Region

The IST connects all the MSTP switches in a region. When the IST converges, the root of the IST becomes the CIST regional root (called the *IST master* before the implementation of the IEEE 802.1s standard) as shown in [Figure 16-1 on page 16-4](#). It is the switch within the region with the lowest switch ID and path cost to the CIST root. The CIST regional root is also the CIST root if there is only one region in the network. If the CIST root is outside the region, one of the MSTP switches at the boundary of the region is selected as the CIST regional root.

When an MSTP switch initializes, it sends BPDUs claiming itself as the root of the CIST and the CIST regional root, with both of the path costs to the CIST root and to the CIST regional root set to zero. The switch also initializes all of its MST instances and claims to be the root for all of them. If the switch receives superior MST root information (lower switch ID, lower path cost, and so forth) than currently stored for the port, it relinquishes its claim as the CIST regional root.

During initialization, a region might have many subregions, each with its own CIST regional root. As switches receive superior IST information, they leave their old subregions and join the new subregion that contains the true CIST regional root. Thus all subregions shrink, except for the one that contains the true CIST regional root.

For correct operation, all switches in the MST region must agree on the same CIST regional root. Therefore, any two switches in the region only synchronize their port roles for an MST instance if they converge to a common CIST regional root.

Operations Between MST Regions

If there are multiple regions or legacy IEEE 802.1D switches within the network, MSTP establishes and maintains the CST, which includes all MST regions and all legacy STP switches in the network. The MST instances combine with the IST at the boundary of the region to become the CST.

The IST connects all the MSTP switches in the region and appears as a subtree in the CIST that encompasses the entire switched domain. The root of the subtree is the CIST regional root. The MST region appears as a virtual switch to adjacent STP switches and MST regions.

Figure 16-1 shows a network with three MST regions and a legacy IEEE 802.1D switch (D). The CIST regional root for region 1 (A) is also the CIST root. The CIST regional root for region 2 (B) and the CIST regional root for region 3 (C) are the roots for their respective subtrees within the CIST. The RSTP runs in all regions.

Figure 16-1 MST Regions, CIST Masters, and CIST Root

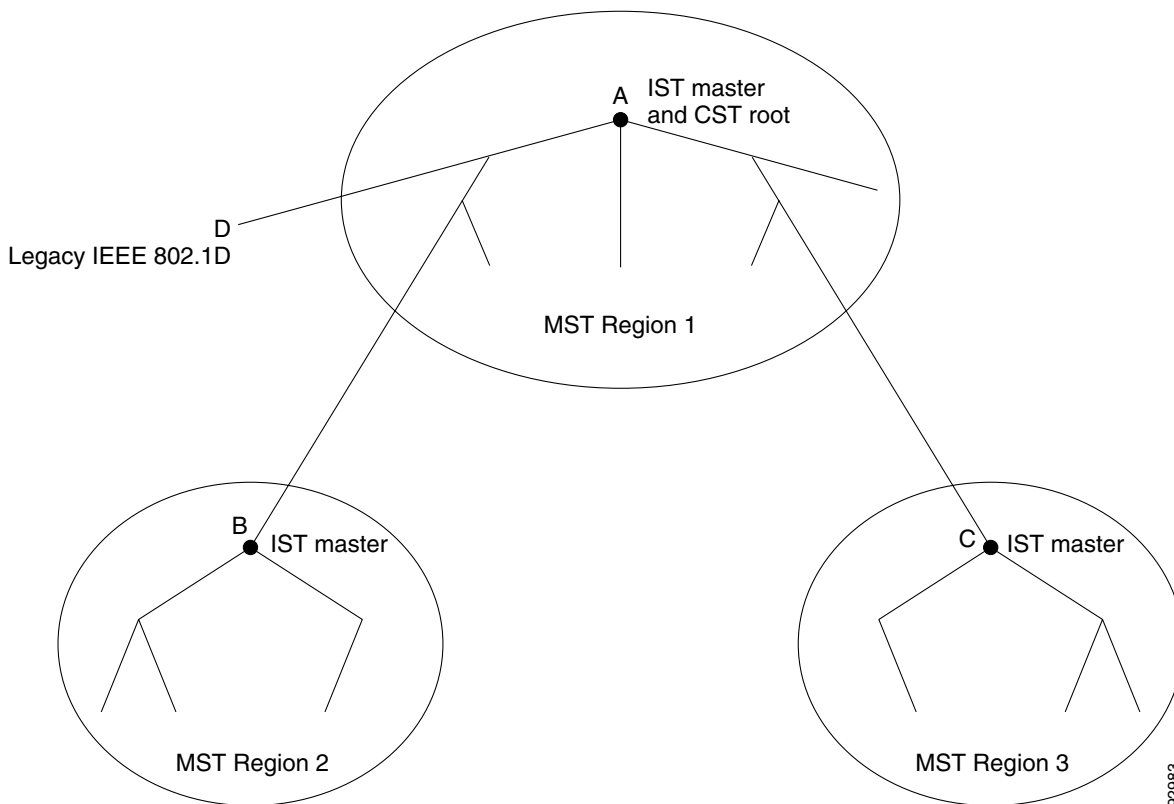

Only the CST instance sends and receives BPDUs, and MST instances add their spanning-tree information into the BPDUs to interact with neighboring switches and compute the final spanning-tree topology. Because of this, the spanning-tree parameters related to BPDU transmission (for example,

hello time, forward time, max-age, and max-hops) are configured only on the CST instance but affect all MST instances. Parameters related to the spanning-tree topology (for example, switch priority, port VLAN cost, and port VLAN priority) can be configured on both the CST instance and the MST instance.

MSTP switches use Version 3 RSTP BPDUs or IEEE 802.1D STP BPDUs to communicate with legacy IEEE 802.1D switches. MSTP switches use MSTP BPDUs to communicate with MSTP switches.

IEEE 802.1s Terminology

Some MST naming conventions used in Cisco's prestandard implementation have been changed to identify some *internal* or *regional* parameters. These parameters are significant only within an MST region, as opposed to external parameters that are relevant to the whole network. Because the CIST is the only spanning-tree instance that spans the whole network, only the CIST parameters require the external rather than the internal or regional qualifiers.

- The CIST root is the root switch for the unique instance that spans the whole network, the CIST.
- The CIST external root path cost is the cost to the CIST root. This cost is left unchanged within an MST region. Remember that an MST region looks like a single switch for the CIST. The CIST external root path cost is the root path cost calculated between these virtual switches and switches that do not belong to any region.
- The CIST regional root was called the IST master in the prestandard implementation. If the CIST root is in the region, the CIST regional root is the CIST root. Otherwise, the CIST regional root is the closest switch to the CIST root in the region. The CIST regional root acts as a root switch for the IST.
- The CIST internal root path cost is the cost to the CIST regional root in a region. This cost is only relevant to the IST, instance 0.

Table 16-1 on page 16-5 compares the IEEE standard and the Cisco prestandard terminology.

Table 16-1 Prestandard and Standard Terminology

IEEE Standard	Cisco Prestandard	Cisco Standard
CIST regional root	IST master	CIST regional root
CIST internal root path cost	IST master path cost	CIST internal path cost
CIST external root path cost	Root path cost	Root path cost
MSTI regional root	Instance root	Instance root
MSTI internal root path cost	Root path cost	Root path cost

Hop Count

The IST and MST instances do not use the message-age and maximum-age information in the configuration BPDU to compute the spanning-tree topology. Instead, they use the path cost to the root and a hop-count mechanism similar to the IP time-to-live (TTL) mechanism.

By using the **spanning-tree mst max-hops** global configuration command, you can configure the maximum hops inside the region and apply it to the IST and all MST instances in that region. The hop count achieves the same result as the message-age information (triggers a reconfiguration). The root switch of the instance always sends a BPDU (or M-record) with a cost of 0 and the hop count set to the

maximum value. When a switch receives this BPDU, it decrements the received remaining hop count by one and propagates this value as the remaining hop count in the BPDUs it generates. When the count reaches zero, the switch discards the BPDU and ages the information held for the port.

The message-age and maximum-age information in the RSTP portion of the BPDU remain the same throughout the region, and the same values are propagated by the region designated ports at the boundary.

Boundary Ports

In the Cisco prestandard implementation, a boundary port connects an MST region to a single spanning-tree region running RSTP, to a single spanning-tree region running PVST+ or rapid PVST+, or to another MST region with a different MST configuration. A boundary port also connects to a LAN, the designated switch of which is either a single spanning-tree switch or a switch with a different MST configuration.

There is no definition of a boundary port in the IEEE 802.1s standard. The IEEE 802.1Q-2002 standard identifies two kinds of messages that a port can receive: internal (coming from the same region) and external. When a message is external, it is received only by the CIST. If the CIST role is root or alternate, or if the external BPDU is a topology change, it could have an impact on the MST instances. When a message is internal, the CIST part is received by the CIST, and each MST instance receives its respective M-record. The Cisco prestandard implementation treats a port that receives an external message as a boundary port. This means a port cannot receive a mix of internal and external messages.

An MST region includes both switches and LANs. A segment belongs to the region of its designated port. Therefore, a port in a different region than the designated port for a segment is a boundary port. This definition allows two ports internal to a region to share a segment with a port belonging to a different region, creating the possibility of receiving both internal and external messages on a port.

The primary change from the Cisco prestandard implementation is that a designated port is not defined as boundary, unless it is running in an STP-compatible mode.

**Note**

If there is a legacy STP switch on the segment, messages are always considered external.

The other change from the prestandard implementation is that the CIST regional root switch ID field is now inserted where an RSTP or legacy IEEE 802.1Q switch has the sender switch ID. The whole region performs like a single virtual switch by sending a consistent sender switch ID to neighboring switches. In this example, switch C would receive a BPDU with the same consistent sender switch ID of root, whether or not A or B is designated for the segment.

IEEE 802.1s Implementation

The Cisco implementation of the IEEE MST standard includes features required to meet the standard, as well as some of the desirable prestandard functionality that is not yet incorporated into the published standard.

Port Role Naming Change

The boundary role is no longer in the final MST standard, but this boundary concept is maintained in Cisco's implementation. However, an MST instance port at a boundary of the region might not follow the state of the corresponding CIST port. Two cases exist now:

- The boundary port is the root port of the CIST regional root—When the CIST instance port is proposed and is in sync, it can send back an agreement and move to the forwarding state only after all the corresponding MSTI ports are in sync (and thus forwarding). The MSTI ports now have a special *master* role.
- The boundary port is not the root port of the CIST regional root—The MSTI ports follow the state and role of the CIST port. The standard provides less information, and it might be difficult to understand why an MSTI port can be alternately blocking when it receives no BPDUs (MRecords). In this case, although the boundary role no longer exists, the **show** commands identify a port as boundary in the *type* column of the output.

Interoperation Between Legacy and Standard Switches

Because automatic detection of prestandard switches can fail, you can use an interface configuration command to identify prestandard ports. A region cannot be formed between a standard and a prestandard switch, but they can interoperate by using the CIST. Only the capability of load balancing over different instances is lost in that particular case. The CLI displays different flags depending on the port configuration when a port receives prestandard BPDUs. A syslog message also appears the first time a switch receives a prestandard BPDU on a port that has not been configured for prestandard BPDU transmission.

Figure 16-2 illustrates this scenario. Assume that A is a standard switch and B a prestandard switch, both configured to be in the same region. A is the root switch for the CIST, and thus B has a root port (BX) on segment X and an alternate port (BY) on segment Y. If segment Y flaps, and the port on BY becomes the alternate before sending out a single prestandard BPDU, AY cannot detect that a prestandard switch is connected to Y and continues to send standard BPDUs. The port BY is thus fixed in a boundary, and no load balancing is possible between A and B. The same problem exists on segment X, but B might transmit topology changes.

Figure 16-2 Standard and Prestandard Switch Interoperation

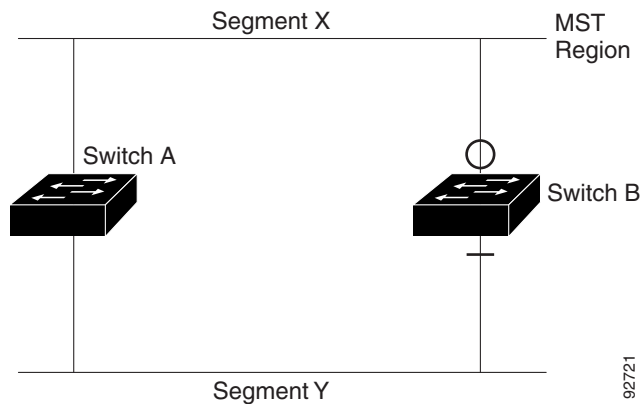

Note

We recommend that you minimize the interaction between standard and prestandard MST implementations.

Detecting Unidirectional Link Failure

This feature is not yet present in the IEEE MST standard, but it is included in this Cisco IOS release. The software checks the consistency of the port role and state in the received BPDUs to detect unidirectional link failures that could cause bridging loops.

When a designated port detects a conflict, it keeps its role, but reverts to discarding state because disrupting connectivity in case of inconsistency is preferable to opening a bridging loop.

Figure 16-3 illustrates a unidirectional link failure that typically creates a bridging loop. Switch A is the root switch, and its BPDUs are lost on the link leading to switch B. RSTP and MST BPDUs include the role and state of the sending port. With this information, switch A can detect that switch B does not react to the superior BPDUs it sends and that switch B is the designated, not root switch. As a result, switch A blocks (or keeps blocking) its port, thus preventing the bridging loop.

Figure 16-3 Detecting Unidirectional Link Failure

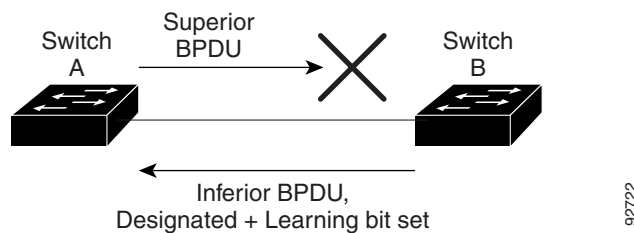

Interoperability with IEEE 802.1D STP

A switch running MSTP supports a built-in protocol migration mechanism that enables it to interoperate with legacy IEEE 802.1D switches. If this switch receives a legacy IEEE 802.1D configuration BPDU (a BPDU with the protocol version set to 0), it sends only IEEE 802.1D BPDUs on that port. An MSTP switch also can detect that a port is at the boundary of a region when it receives a legacy BPDU, an MSTP BPDU (Version 3) associated with a different region, or an RSTP BPDU (Version 2).

However, the switch does not automatically revert to the MSTP mode if it no longer receives IEEE 802.1D BPDUs because it cannot detect whether the legacy switch has been removed from the link unless the legacy switch is the designated switch. A switch might also continue to assign a boundary role to a port when the switch to which this switch is connected has joined the region. To restart the protocol migration process (force the renegotiation with neighboring switches), use the **clear spanning-tree detected-protocols** privileged EXEC command.

If all the legacy switches on the link are RSTP switches, they can process MSTP BPDUs as if they are RSTP BPDUs. Therefore, MSTP switches send either a Version 0 configuration and TCN BPDUs or Version 3 MSTP BPDUs on a boundary port. A boundary port connects to a LAN, the designated switch of which is either a single spanning-tree switch or a switch with a different MST configuration.

Understanding RSTP

The RSTP takes advantage of point-to-point wiring and provides rapid convergence of the spanning tree. Reconfiguration of the spanning tree can occur in less than 1 second (in contrast to 50 seconds with the default settings in the IEEE 802.1D spanning tree).

These sections describe how the RSTP works:

- [Port Roles and the Active Topology, page 16-9](#)
- [Rapid Convergence, page 16-10](#)
- [Synchronization of Port Roles, page 16-11](#)
- [Bridge Protocol Data Unit Format and Processing, page 16-12](#)

For configuration information, see the “[Configuring MSTP Features](#)” section on page 16-14.

Port Roles and the Active Topology

The RSTP provides rapid convergence of the spanning tree by assigning port roles and by learning the active topology. The RSTP builds upon the IEEE 802.1D STP to select the switch with the highest switch priority (lowest numerical priority value) as the root switch as described in the “[Spanning-Tree Topology and BPDUs](#)” section on page 15-3. Then the RSTP assigns one of these port roles to individual ports:

- **Root port**—Provides the best path (lowest cost) when the switch forwards packets to the root switch.
- **Designated port**—Connects to the designated switch, which incurs the lowest path cost when forwarding packets from that LAN to the root switch. The port through which the designated switch is attached to the LAN is called the designated port.
- **Alternate port**—Offers an alternate path toward the root switch to that provided by the current root port.
- **Backup port**—Acts as a backup for the path provided by a designated port toward the leaves of the spanning tree. A backup port can exist only when two ports are connected in a loopback by a point-to-point link or when a switch has two or more connections to a shared LAN segment.
- **Disabled port**—Has no role within the operation of the spanning tree.

A port with the root or a designated port role is included in the active topology. A port with the alternate or backup port role is excluded from the active topology.

In a stable topology with consistent port roles throughout the network, the RSTP ensures that every root port and designated port immediately transition to the forwarding state while all alternate and backup ports are always in the discarding state (equivalent to blocking in IEEE 802.1D). The port state controls the operation of the forwarding and learning processes. [Table 16-2](#) provides a comparison of IEEE 802.1D and RSTP port states.

Table 16-2 Port State Comparison

Operational Status	STP Port State (IEEE 802.1D)	RSTP Port State	Is Port Included in the Active Topology?
Enabled	Blocking	Discarding	No
Enabled	Listening	Discarding	No
Enabled	Learning	Learning	Yes
Enabled	Forwarding	Forwarding	Yes
Disabled	Disabled	Discarding	No

To be consistent with Cisco STP implementations, this guide defines the port state as *blocking* instead of *discarding*. Designated ports start in the listening state.

Rapid Convergence

The RSTP provides for rapid recovery of connectivity following the failure of a switch, a switch port, or a LAN. It provides rapid convergence for edge ports, new root ports, and ports connected through point-to-point links as follows:

- **Edge ports**—If you configure a port as an edge port on an RSTP switch by using the **spanning-tree portfast** interface configuration command, the edge port immediately transitions to the forwarding state. An edge port is the same as a Port Fast-enabled port, and you should enable it only on ports that connect to a single end station.
- **Root ports**—If the RSTP selects a new root port, it blocks the old root port and immediately transitions the new root port to the forwarding state.
- **Point-to-point links**—If you connect a port to another port through a point-to-point link and the local port becomes a designated port, it negotiates a rapid transition with the other port by using the proposal-agreement handshake to ensure a loop-free topology.

As shown in [Figure 16-4](#), Switch A is connected to Switch B through a point-to-point link, and all of the ports are in the blocking state. Assume that the priority of Switch A is a smaller numerical value than the priority of Switch B. Switch A sends a proposal message (a configuration BPDU with the proposal flag set) to Switch B, proposing itself as the designated switch.

After receiving the proposal message, Switch B selects as its new root port the port from which the proposal message was received, forces all nonedge ports to the blocking state, and sends an agreement message (a BPDU with the agreement flag set) through its new root port.

After receiving Switch B's agreement message, Switch A also immediately transitions its designated port to the forwarding state. No loops in the network are formed because Switch B blocked all of its nonedge ports and because there is a point-to-point link between Switches A and B.

When Switch C is connected to Switch B, a similar set of handshaking messages are exchanged. Switch C selects the port connected to Switch B as its root port, and both ends immediately transition to the forwarding state. With each iteration of this handshaking process, one more switch joins the active topology. As the network converges, this proposal-agreement handshaking progresses from the root toward the leaves of the spanning tree.

The switch learns the link type from the port duplex mode: a full-duplex port is considered to have a point-to-point connection; a half-duplex port is considered to have a shared connection. You can override the default setting that is controlled by the duplex setting by using the **spanning-tree link-type** interface configuration command.

Figure 16-4 Proposal and Agreement Handshaking for Rapid Convergence

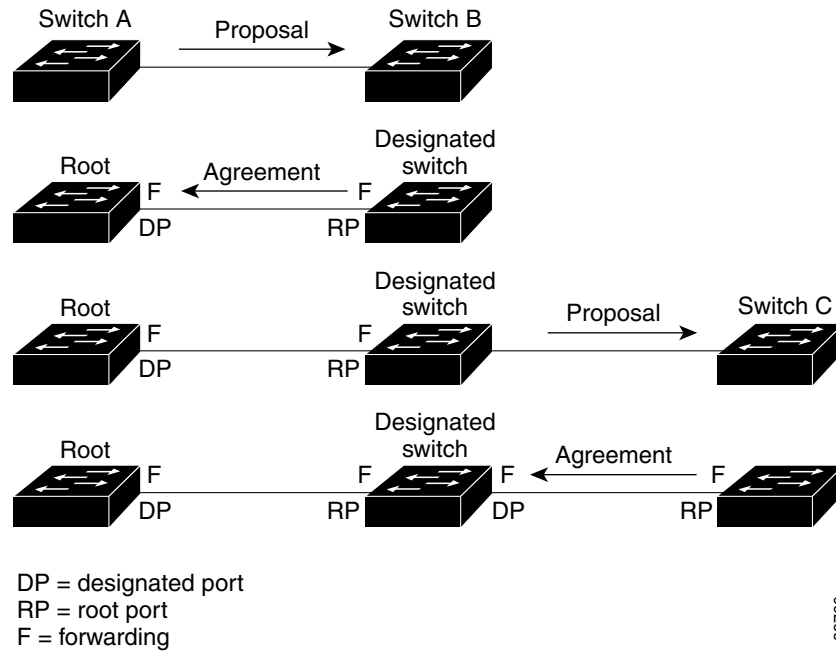

Synchronization of Port Roles

When the switch receives a proposal message on one of its ports and that port is selected as the new root port, the RSTP forces all other ports to synchronize with the new root information.

The switch is synchronized with superior root information received on the root port if all other ports are synchronized. An individual port on the switch is synchronized if

- That port is in the blocking state.
- It is an edge port (a port configured to be at the edge of the network).

If a designated port is in the forwarding state and is not configured as an edge port, it transitions to the blocking state when the RSTP forces it to synchronize with new root information. In general, when the RSTP forces a port to synchronize with root information and the port does not satisfy any of the above conditions, its port state is set to blocking.

After ensuring that all of the ports are synchronized, the switch sends an agreement message to the designated switch corresponding to its root port. When the switches connected by a point-to-point link are in agreement about their port roles, the RSTP immediately transitions the port states to forwarding. The sequence of events is shown in Figure 16-5.

Figure 16-5 Sequence of Events During Rapid Convergence

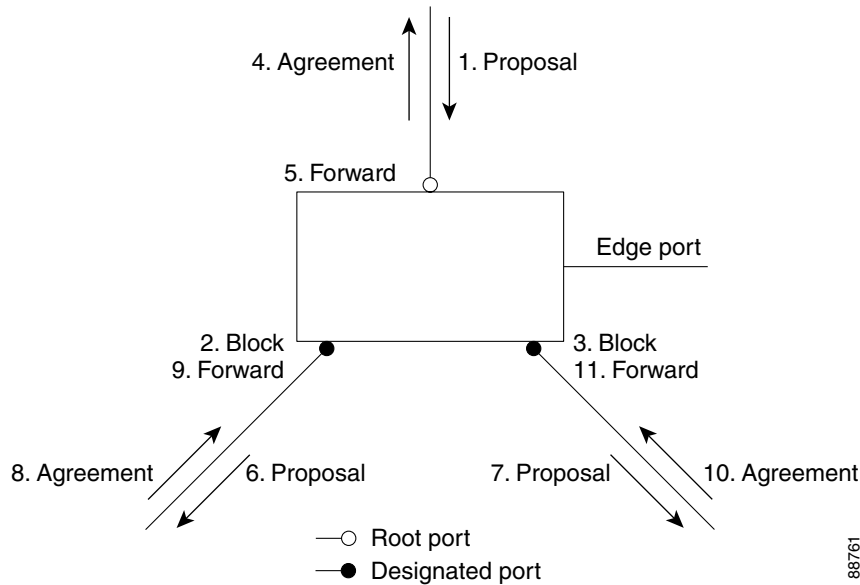

Bridge Protocol Data Unit Format and Processing

The RSTP BPDU format is the same as the IEEE 802.1D BPDU format except that the protocol version is set to 2. A new 1-byte Version 1 Length field is set to zero, which means that no version 1 protocol information is present. Table 16-3 shows the RSTP flag fields.

Table 16-3 RSTP BPDU Flags

Bit	Function
0	Topology change (TC)
1	Proposal
2–3:	Port role:
00	Unknown
01	Alternate port
10	Root port
11	Designated port
4	Learning
5	Forwarding
6	Agreement
7	Topology change acknowledgement (TCA)

The sending switch sets the proposal flag in the RSTP BPDU to propose itself as the designated switch on that LAN. The port role in the proposal message is always set to the designated port.

The sending switch sets the agreement flag in the RSTP BPDU to accept the previous proposal. The port role in the agreement message is always set to the root port.

The RSTP does not have a separate topology change notification (TCN) BPDU. It uses the topology change (TC) flag to show the topology changes. However, for interoperability with IEEE 802.1D switches, the RSTP switch processes and generates TCN BPDUs.

The learning and forwarding flags are set according to the state of the sending port.

Processing Superior BPDU Information

If a port receives superior root information (lower switch ID, lower path cost, and so forth) than currently stored for the port, the RSTP triggers a reconfiguration. If the port is proposed and is selected as the new root port, RSTP forces all the other ports to synchronize.

If the BPDU received is an RSTP BPDU with the proposal flag set, the switch sends an agreement message after all of the other ports are synchronized. If the BPDU is an IEEE 802.1D BPDU, the switch does not set the proposal flag and starts the forward-delay timer for the port. The new root port requires twice the forward-delay time to transition to the forwarding state.

If the superior information received on the port causes the port to become a backup or alternate port, RSTP sets the port to the blocking state but does not send the agreement message. The designated port continues sending BPDUs with the proposal flag set until the forward-delay timer expires, at which time the port transitions to the forwarding state.

Processing Inferior BPDU Information

If a designated port receives an inferior BPDU (higher switch ID, higher path cost, and so forth than currently stored for the port) with a designated port role, it immediately replies with its own information.

Topology Changes

This section describes the differences between the RSTP and the IEEE 802.1D in handling spanning-tree topology changes.

- **Detection**—Unlike IEEE 802.1D in which *any* transition between the blocking and the forwarding state causes a topology change, *only* transitions from the blocking to the forwarding state cause a topology change with RSTP (only an increase in connectivity is considered a topology change). State changes on an edge port do not cause a topology change. When an RSTP switch detects a topology change, it deletes the learned information on all of its nonedge ports except on those from which it received the TC notification.
- **Notification**—Unlike IEEE 802.1D, which uses TCN BPDUs, the RSTP does not use them. However, for IEEE 802.1D interoperability, an RSTP switch processes and generates TCN BPDUs.
- **Acknowledgement**—When an RSTP switch receives a TCN message on a designated port from an IEEE 802.1D switch, it replies with an IEEE 802.1D configuration BPDU with the TCA bit set. However, if the TC-while timer (the same as the topology-change timer in IEEE 802.1D) is active on a root port connected to an IEEE 802.1D switch and a configuration BPDU with the TCA bit set is received, the TC-while timer is reset.

This behavior is only required to support IEEE 802.1D switches. The RSTP BPDUs never have the TCA bit set.

- Propagation—When an RSTP switch receives a TC message from another switch through a designated or root port, it propagates the change to all of its nonedge, designated ports and to the root port (excluding the port on which it is received). The switch starts the TC-while timer for all such ports and flushes the information learned on them.
- Protocol migration—For backward compatibility with IEEE 802.1D switches, RSTP selectively sends IEEE 802.1D configuration BPDUs and TCN BPDUs on a per-port basis.

When a port is initialized, the migrate-delay timer is started (specifies the minimum time during which RSTP BPDUs are sent), and RSTP BPDUs are sent. While this timer is active, the switch processes all BPDUs received on that port and ignores the protocol type.

If the switch receives an IEEE 802.1D BPDU after the port migration-delay timer has expired, it assumes that it is connected to an IEEE 802.1D switch and starts using only IEEE 802.1D BPDUs. However, if the RSTP switch is using IEEE 802.1D BPDUs on a port and receives an RSTP BPDU after the timer has expired, it restarts the timer and starts using RSTP BPDUs on that port.

Configuring MSTP Features

These sections contain this configuration information:

- [Default MSTP Configuration, page 16-14](#)
- [MSTP Configuration Guidelines, page 16-15](#)
- [Specifying the MST Region Configuration and Enabling MSTP, page 16-16](#) (required)
- [Configuring the Root Switch, page 16-17](#) (optional)
- [Configuring a Secondary Root Switch, page 16-18](#) (optional)
- [Configuring Port Priority, page 16-19](#) (optional)
- [Configuring Path Cost, page 16-20](#) (optional)
- [Configuring the Switch Priority, page 16-21](#) (optional)
- [Configuring the Hello Time, page 16-22](#) (optional)
- [Configuring the Forwarding-Delay Time, page 16-23](#) (optional)
- [Configuring the Maximum-Aging Time, page 16-23](#) (optional)
- [Configuring the Maximum-Hop Count, page 16-24](#) (optional)
- [Specifying the Link Type to Ensure Rapid Transitions, page 16-24](#) (optional)
- [Designating the Neighbor Type, page 16-25](#) (optional)
- [Restarting the Protocol Migration Process, page 16-25](#) (optional)

Default MSTP Configuration

Table 16-4 shows the default MSTP configuration.

Table 16-4 *Default MSTP Configuration*

Feature	Default Setting
Spanning-tree mode	PVST+ (Rapid PVST+ and MSTP are disabled).
Switch priority (configurable on a per-CIST port basis)	32768.

Table 16-4 Default MSTP Configuration (continued)

Feature	Default Setting
Spanning-tree port priority (configurable on a per-CIST port basis)	128.
Spanning-tree port cost (configurable on a per-CIST port basis)	1000 Mbps: 4. 100 Mbps: 19. 10 Mbps: 100.
Hello time	2 seconds.
Forward-delay time	15 seconds.
Maximum-aging time	20 seconds.
Maximum hop count	20 hops.

For information about the supported number of spanning-tree instances, see the [“Supported Spanning-Tree Instances”](#) section on page 15-9.

MSTP Configuration Guidelines

These are the configuration guidelines for MSTP:

- When you enable MST by using the **spanning-tree mode mst** global configuration command, RSTP is automatically enabled.
- For two or more switches to be in the same MST region, they must have the same VLAN-to-instance map, the same configuration revision number, and the same name.
- The switch supports up to 65 MST instances. The number of VLANs that can be mapped to a particular MST instance is unlimited.
- PVST+, rapid PVST+, and MSTP are supported, but only one version can be active at any time. (For example, all VLANs run PVST+, all VLANs run rapid PVST+, or all VLANs run MSTP.) For more information, see the [“Spanning-Tree Interoperability and Backward Compatibility”](#) section on page 15-10. For information on the recommended trunk port configuration, see the [“Interaction with Other Features”](#) section on page 12-16.
- VTP propagation of the MST configuration is not supported. However, you can manually configure the MST configuration (region name, revision number, and VLAN-to-instance mapping) on each switch within the MST region by using the command-line interface (CLI) or through the SNMP support.
- For load balancing across redundant paths in the network to work, all VLAN-to-instance mapping assignments must match; otherwise, all traffic flows on a single link.
- All MST boundary ports must be forwarding for load balancing between a PVST+ and an MST cloud or between a rapid-PVST+ and an MST cloud. For this to occur, the IST master of the MST cloud should also be the root of the CST. If the MST cloud consists of multiple MST regions, one of the MST regions must contain the CST root, and all of the other MST regions must have a better path to the root contained within the MST cloud than a path through the PVST+ or rapid-PVST+ cloud. You might have to manually configure the switches in the clouds.

- Partitioning the network into a large number of regions is not recommended. However, if this situation is unavoidable, we recommend that you partition the switched LAN into smaller LANs interconnected by routers or non-Layer 2 devices.
- For configuration guidelines about UplinkFast and BackboneFast, see the “[Optional Spanning-Tree Configuration Guidelines](#)” section on page 17-10.

Specifying the MST Region Configuration and Enabling MSTP

For two or more switches to be in the same MST region, they must have the same VLAN-to-instance mapping, the same configuration revision number, and the same name.

A region can have one member or multiple members with the same MST configuration; each member must be capable of processing RSTP BPDUs. There is no limit to the number of MST regions in a network, but each region can only support up to 65 spanning-tree instances. You can assign a VLAN to only one spanning-tree instance at a time.

Beginning in privileged EXEC mode, follow these steps to specify the MST region configuration and enable MSTP. This procedure is required.

	Command	Purpose
Step 1	configure terminal	Enter global configuration mode.
Step 2	spanning-tree mst configuration	Enter MST configuration mode.
Step 3	instance <i>instance-id</i> vlan <i>vlan-range</i>	Map VLANs to an MST instance. <ul style="list-style-type: none"> • For <i>instance-id</i>, the range is 0 to 4094. • For vlan <i>vlan-range</i>, the range is 1 to 4094. <p>When you map VLANs to an MST instance, the mapping is incremental, and the VLANs specified in the command are added to or removed from the VLANs that were previously mapped.</p> <p>To specify a VLAN range, use a hyphen; for example, instance 1 vlan 1-63 maps VLANs 1 through 63 to MST instance 1.</p> <p>To specify a VLAN series, use a comma; for example, instance 1 vlan 10, 20, 30 maps VLANs 10, 20, and 30 to MST instance 1.</p>
Step 4	name <i>name</i>	Specify the configuration name. The <i>name</i> string has a maximum length of 32 characters and is case sensitive.
Step 5	revision <i>version</i>	Specify the configuration revision number. The range is 0 to 65535.
Step 6	show pending	Verify your configuration by displaying the pending configuration.
Step 7	exit	Apply all changes, and return to global configuration mode.
Step 8	spanning-tree mode mst	Enable MSTP. RSTP is also enabled. <div style="border: 1px solid black; padding: 5px; margin-top: 10px;">  <p>Caution Changing spanning-tree modes can disrupt traffic because all spanning-tree instances are stopped for the previous mode and restarted in the new mode.</p> </div> <p>You cannot run both MSTP and PVST+ or both MSTP and rapid PVST+ at the same time.</p>

	Command	Purpose
Step 9	end	Return to privileged EXEC mode.
Step 10	show running-config	Verify your entries.
Step 11	copy running-config startup-config	(Optional) Save your entries in the configuration file.

To return to the default MST region configuration, use the **no spanning-tree mst configuration** global configuration command. To return to the default VLAN-to-instance map, use the **no instance instance-id [vlan vlan-range]** MST configuration command. To return to the default name, use the **no name** MST configuration command. To return to the default revision number, use the **no revision** MST configuration command. To re-enable PVST+, use the **no spanning-tree mode** or the **spanning-tree mode pvst** global configuration command.

This example shows how to enter MST configuration mode, map VLANs 10 to 20 to MST instance 1, name the region *region1*, set the configuration revision to 1, display the pending configuration, apply the changes, and return to global configuration mode:

```
Switch(config)# spanning-tree mst configuration
Switch(config-mst)# instance 1 vlan 10-20
Switch(config-mst)# name region1
Switch(config-mst)# revision 1
Switch(config-mst)# show pending
Pending MST configuration
Name      [region1]
Revision  1
Instance  Vlans Mapped
-----
0         1-9,21-4094
1         10-20
-----

Switch(config-mst)# exit
Switch(config)#
```

Configuring the Root Switch

The switch maintains a spanning-tree instance for the group of VLANs mapped to it. A switch ID, consisting of the switch priority and the switch MAC address, is associated with each instance. For a group of VLANs, the switch with the lowest switch ID becomes the root switch.

To configure a switch to become the root, use the **spanning-tree mst instance-id root** global configuration command to modify the switch priority from the default value (32768) to a significantly lower value so that the switch becomes the root switch for the specified spanning-tree instance. When you enter this command, the switch checks the switch priorities of the root switches. Because of the extended system ID support, the switch sets its own priority for the specified instance to 24576 if this value will cause this switch to become the root for the specified spanning-tree instance.

If any root switch for the specified instance has a switch priority lower than 24576, the switch sets its own priority to 4096 less than the lowest switch priority. (4096 is the value of the least-significant bit of a 4-bit switch priority value as shown in [Table 15-1 on page 15-4](#).)

If your network consists of switches that both do and do not support the extended system ID, it is unlikely that the switch with the extended system ID support will become the root switch. The extended system ID increases the switch priority value every time the VLAN number is greater than the priority of the connected switches running older software.

The root switch for each spanning-tree instance should be a backbone or distribution switch. Do not configure an access switch as the spanning-tree primary root.

Use the **diameter** keyword, which is available only for MST instance 0, to specify the Layer 2 network diameter (that is, the maximum number of switch hops between any two end stations in the Layer 2 network). When you specify the network diameter, the switch automatically sets an optimal hello time, forward-delay time, and maximum-age time for a network of that diameter, which can significantly reduce the convergence time. You can use the **hello** keyword to override the automatically calculated hello time.

**Note**

After configuring the switch as the root switch, we recommend that you avoid manually configuring the hello time, forward-delay time, and maximum-age time through the **spanning-tree mst hello-time**, **spanning-tree mst forward-time**, and the **spanning-tree mst max-age** global configuration commands.

Beginning in privileged EXEC mode, follow these steps to configure a switch as the root switch. This procedure is optional.

	Command	Purpose
Step 1	configure terminal	Enter global configuration mode.
Step 2	spanning-tree mst <i>instance-id</i> root primary [<i>diameter net-diameter</i> [<i>hello-time seconds</i>]]	Configure a switch as the root switch. <ul style="list-style-type: none"> For <i>instance-id</i>, you can specify a single instance, a range of instances separated by a hyphen, or a series of instances separated by a comma. The range is 0 to 4094. (Optional) For diameter <i>net-diameter</i>, specify the maximum number of switches between any two end stations. The range is 2 to 7. This keyword is available only for MST instance 0. (Optional) For hello-time <i>seconds</i>, specify the interval in seconds between the generation of configuration messages by the root switch. The range is 1 to 10 seconds; the default is 2 seconds.
Step 3	end	Return to privileged EXEC mode.
Step 4	show spanning-tree mst <i>instance-id</i>	Verify your entries.
Step 5	copy running-config startup-config	(Optional) Save your entries in the configuration file.

To return the switch to its default setting, use the **no spanning-tree mst *instance-id* root** global configuration command.

Configuring a Secondary Root Switch

When you configure a switch with the extended system ID support as the secondary root, the switch priority is modified from the default value (32768) to 28672. The switch is then likely to become the root switch for the specified instance if the primary root switch fails. This is assuming that the other network switches use the default switch priority of 32768 and therefore are unlikely to become the root switch.

You can execute this command on more than one switch to configure multiple backup root switches. Use the same network diameter and hello-time values that you used when you configured the primary root switch with the **spanning-tree mst *instance-id* root primary** global configuration command.

Beginning in privileged EXEC mode, follow these steps to configure a switch as the secondary root switch. This procedure is optional.

	Command	Purpose
Step 1	configure terminal	Enter global configuration mode.
Step 2	spanning-tree mst <i>instance-id</i> root secondary [diameter <i>net-diameter</i> [hello-time <i>seconds</i>]]	Configure a switch as the secondary root switch. <ul style="list-style-type: none"> • For <i>instance-id</i>, you can specify a single instance, a range of instances separated by a hyphen, or a series of instances separated by a comma. The range is 0 to 4094. • (Optional) For diameter <i>net-diameter</i>, specify the maximum number of switches between any two end stations. The range is 2 to 7. This keyword is available only for MST instance 0. • (Optional) For hello-time <i>seconds</i>, specify the interval in seconds between the generation of configuration messages by the root switch. The range is 1 to 10 seconds; the default is 2 seconds. Use the same network diameter and hello-time values that you used when configuring the primary root switch. See the “Configuring the Root Switch” section on page 16-17.
Step 3	end	Return to privileged EXEC mode.
Step 4	show spanning-tree mst <i>instance-id</i>	Verify your entries.
Step 5	copy running-config startup-config	(Optional) Save your entries in the configuration file.

To return the switch to its default setting, use the **no spanning-tree mst *instance-id* root** global configuration command.

Configuring Port Priority

If a loop occurs, the MSTP uses the port priority when selecting an interface to put into the forwarding state. You can assign higher priority values (lower numerical values) to interfaces that you want selected first and lower priority values (higher numerical values) that you want selected last. If all interfaces have the same priority value, the MSTP puts the interface with the lowest interface number in the forwarding state and blocks the other interfaces.

Beginning in privileged EXEC mode, follow these steps to configure the MSTP port priority of an interface. This procedure is optional.

	Command	Purpose
Step 1	configure terminal	Enter global configuration mode.
Step 2	interface <i>interface-id</i>	Specify an interface to configure, and enter interface configuration mode. Valid interfaces include physical ports and port-channel logical interfaces. The port-channel range is 1 to 6.
Step 3	spanning-tree mst <i>instance-id</i> port-priority <i>priority</i>	Configure the port priority. <ul style="list-style-type: none"> For <i>instance-id</i>, you can specify a single instance, a range of instances separated by a hyphen, or a series of instances separated by a comma. The range is 0 to 4094. For <i>priority</i>, the range is 0 to 240 in increments of 16. The default is 128. The lower the number, the higher the priority. <p>The priority values are 0, 16, 32, 48, 64, 80, 96, 112, 128, 144, 160, 176, 192, 208, 224, and 240. All other values are rejected.</p>
Step 4	end	Return to privileged EXEC mode.
Step 5	show spanning-tree mst interface <i>interface-id</i> or show spanning-tree mst <i>instance-id</i>	Verify your entries.
Step 6	copy running-config startup-config	(Optional) Save your entries in the configuration file.

**Note**

The **show spanning-tree mst interface** *interface-id* privileged EXEC command displays information only if the port is in a link-up operative state. Otherwise, you can use the **show running-config interface** privileged EXEC command to confirm the configuration.

To return the interface to its default setting, use the **no spanning-tree mst** *instance-id* **port-priority** interface configuration command.

Configuring Path Cost

The MSTP path cost default value is derived from the media speed of an interface. If a loop occurs, the MSTP uses cost when selecting an interface to put in the forwarding state. You can assign lower cost values to interfaces that you want selected first and higher cost values that you want selected last. If all interfaces have the same cost value, the MSTP puts the interface with the lowest interface number in the forwarding state and blocks the other interfaces.

Beginning in privileged EXEC mode, follow these steps to configure the MSTP cost of an interface. This procedure is optional.

	Command	Purpose
Step 1	configure terminal	Enter global configuration mode.
Step 2	interface <i>interface-id</i>	Specify an interface to configure, and enter interface configuration mode. Valid interfaces include physical ports and port-channel logical interfaces. The port-channel range is 1 to 6.
Step 3	spanning-tree mst <i>instance-id</i> cost <i>cost</i>	Configure the cost. If a loop occurs, the MSTP uses the path cost when selecting an interface to place into the forwarding state. A lower path cost represents higher-speed transmission. <ul style="list-style-type: none"> For <i>instance-id</i>, you can specify a single instance, a range of instances separated by a hyphen, or a series of instances separated by a comma. The range is 0 to 4094. For <i>cost</i>, the range is 1 to 200000000; the default value is derived from the media speed of the interface.
Step 4	end	Return to privileged EXEC mode.
Step 5	show spanning-tree mst interface <i>interface-id</i> or show spanning-tree mst <i>instance-id</i>	Verify your entries.
Step 6	copy running-config startup-config	(Optional) Save your entries in the configuration file.

**Note**

The **show spanning-tree mst interface** *interface-id* privileged EXEC command displays information only for ports that are in a link-up operative state. Otherwise, you can use the **show running-config** privileged EXEC command to confirm the configuration.

To return the interface to its default setting, use the **no spanning-tree mst** *instance-id* **cost** interface configuration command.

Configuring the Switch Priority

You can configure the switch priority and make it more likely that the switch will be chosen as the root switch.

**Note**

Exercise care when using this command. For most situations, we recommend that you use the **spanning-tree mst** *instance-id* **root primary** and the **spanning-tree mst** *instance-id* **root secondary** global configuration commands to modify the switch priority.

Beginning in privileged EXEC mode, follow these steps to configure the switch priority. This procedure is optional.

	Command	Purpose
Step 1	configure terminal	Enter global configuration mode.
Step 2	spanning-tree mst <i>instance-id</i> priority <i>priority</i>	Configure the switch priority. <ul style="list-style-type: none"> For <i>instance-id</i>, you can specify a single instance, a range of instances separated by a hyphen, or a series of instances separated by a comma. The range is 0 to 4094. For <i>priority</i>, the range is 0 to 61440 in increments of 4096; the default is 32768. The lower the number, the more likely the switch will be chosen as the root switch. Priority values are 0, 4096, 8192, 12288, 16384, 20480, 24576, 28672, 32768, 36864, 40960, 45056, 49152, 53248, 57344, and 61440. All other values are rejected.
Step 3	end	Return to privileged EXEC mode.
Step 4	show spanning-tree mst <i>instance-id</i>	Verify your entries.
Step 5	copy running-config startup-config	(Optional) Save your entries in the configuration file.

To return the switch to its default setting, use the **no spanning-tree mst *instance-id* priority** global configuration command.

Configuring the Hello Time

You can configure the interval between the generation of configuration messages by the root switch by changing the hello time.

Beginning in privileged EXEC mode, follow these steps to configure the hello time for all MST instances. This procedure is optional.

	Command	Purpose
Step 1	configure terminal	Enter global configuration mode.
Step 2	spanning-tree mst hello-time <i>seconds</i>	Configure the hello time for all MST instances. The hello time is the interval between the generation of configuration messages by the root switch. These messages mean that the switch is alive. For <i>seconds</i> , the range is 1 to 10; the default is 2.
Step 3	end	Return to privileged EXEC mode.
Step 4	show spanning-tree mst	Verify your entries.
Step 5	copy running-config startup-config	(Optional) Save your entries in the configuration file.

To return the switch to its default setting, use the **no spanning-tree mst hello-time** global configuration command.

Configuring the Forwarding-Delay Time

Beginning in privileged EXEC mode, follow these steps to configure the forwarding-delay time for all MST instances. This procedure is optional.

	Command	Purpose
Step 1	configure terminal	Enter global configuration mode.
Step 2	spanning-tree mst forward-time <i>seconds</i>	Configure the forward time for all MST instances. The forward delay is the number of seconds a port waits before changing from its spanning-tree learning and listening states to the forwarding state. For <i>seconds</i> , the range is 4 to 30; the default is 15.
Step 3	end	Return to privileged EXEC mode.
Step 4	show spanning-tree mst	Verify your entries.
Step 5	copy running-config startup-config	(Optional) Save your entries in the configuration file.

To return the switch to its default setting, use the **no spanning-tree mst forward-time** global configuration command.

Configuring the Maximum-Aging Time

Beginning in privileged EXEC mode, follow these steps to configure the maximum-aging time for all MST instances. This procedure is optional.

	Command	Purpose
Step 1	configure terminal	Enter global configuration mode.
Step 2	spanning-tree mst max-age <i>seconds</i>	Configure the maximum-aging time for all MST instances. The maximum-aging time is the number of seconds a switch waits without receiving spanning-tree configuration messages before attempting a reconfiguration. For <i>seconds</i> , the range is 6 to 40; the default is 20.
Step 3	end	Return to privileged EXEC mode.
Step 4	show spanning-tree mst	Verify your entries.
Step 5	copy running-config startup-config	(Optional) Save your entries in the configuration file.

To return the switch to its default setting, use the **no spanning-tree mst max-age** global configuration command.

Configuring the Maximum-Hop Count

Beginning in privileged EXEC mode, follow these steps to configure the maximum-hop count for all MST instances. This procedure is optional.

	Command	Purpose
Step 1	configure terminal	Enter global configuration mode.
Step 2	spanning-tree mst max-hops <i>hop-count</i>	Specify the number of hops in a region before the BPDU is discarded, and the information held for a port is aged. For <i>hop-count</i> , the range is 1 to 255; the default is 20.
Step 3	end	Return to privileged EXEC mode.
Step 4	show spanning-tree mst	Verify your entries.
Step 5	copy running-config startup-config	(Optional) Save your entries in the configuration file.

To return the switch to its default setting, use the **no spanning-tree mst max-hops** global configuration command.

Specifying the Link Type to Ensure Rapid Transitions

If you connect a port to another port through a point-to-point link and the local port becomes a designated port, the RSTP negotiates a rapid transition with the other port by using the proposal-agreement handshake to ensure a loop-free topology as described in the [“Rapid Convergence” section on page 16-10](#).

By default, the link type is controlled from the duplex mode of the interface: a full-duplex port is considered to have a point-to-point connection; a half-duplex port is considered to have a shared connection. If you have a half-duplex link physically connected point-to-point to a single port on a remote switch running MSTP, you can override the default setting of the link type and enable rapid transitions to the forwarding state.

Beginning in privileged EXEC mode, follow these steps to override the default link-type setting. This procedure is optional.

	Command	Purpose
Step 1	configure terminal	Enter global configuration mode.
Step 2	interface <i>interface-id</i>	Specify an interface to configure, and enter interface configuration mode. Valid interfaces include physical ports, VLANs, and port-channel logical interfaces. The VLAN ID range is 1 to 4094. The port-channel range is 1 to 6.
Step 3	spanning-tree link-type point-to-point	Specify that the link type of a port is point-to-point.
Step 4	end	Return to privileged EXEC mode.
Step 5	show spanning-tree mst interface <i>interface-id</i>	Verify your entries.
Step 6	copy running-config startup-config	(Optional) Save your entries in the configuration file.

To return the port to its default setting, use the **no spanning-tree link-type** interface configuration command.

Designating the Neighbor Type

A topology could contain both prestandard and IEEE 802.1s standard compliant devices. By default, ports can automatically detect prestandard devices, but they can still receive both standard and prestandard BPDUs. When there is a mismatch between a device and its neighbor, only the CIST runs on the interface.

You can choose to set a port to send only prestandard BPDUs. The prestandard flag appears in all the show commands, even if the port is in STP compatibility mode.

Beginning in privileged EXEC mode, follow these steps to override the default link-type setting. This procedure is optional.

	Command	Purpose
Step 1	configure terminal	Enter global configuration mode.
Step 2	interface <i>interface-id</i>	Specify an interface to configure, and enter interface configuration mode. Valid interfaces include physical ports.
Step 3	spanning-tree mst pre-standard	Specify that the port can send only prestandard BPDUs.
Step 4	end	Return to privileged EXEC mode.
Step 5	show spanning-tree mst interface <i>interface-id</i>	Verify your entries.
Step 6	copy running-config startup-config	(Optional) Save your entries in the configuration file.

To return the port to its default setting, use the **no spanning-tree mst prestandard** interface configuration command.

Restarting the Protocol Migration Process

A switch running MSTP supports a built-in protocol migration mechanism that enables it to interoperate with legacy IEEE 802.1D switches. If this switch receives a legacy IEEE 802.1D configuration BPDU (a BPDU with the protocol version set to 0), it sends only IEEE 802.1D BPDUs on that port. An MSTP switch also can detect that a port is at the boundary of a region when it receives a legacy BPDU, an MST BPDU (Version 3) associated with a different region, or an RST BPDU (Version 2).

However, the switch does not automatically revert to the MSTP mode if it no longer receives IEEE 802.1D BPDUs because it cannot detect whether the legacy switch has been removed from the link unless the legacy switch is the designated switch. A switch also might continue to assign a boundary role to a port when the switch to which it is connected has joined the region.

To restart the protocol migration process (force the renegotiation with neighboring switches) on the switch, use the **clear spanning-tree detected-protocols** privileged EXEC command.

To restart the protocol migration process on a specific interface, use the **clear spanning-tree detected-protocols interface** *interface-id* privileged EXEC command.

Displaying the MST Configuration and Status

To display the spanning-tree status, use one or more of the privileged EXEC commands in [Table 16-5](#):

Table 16-5 **Commands for Displaying MST Status**

Command	Purpose
<code>show spanning-tree mst configuration</code>	Displays the MST region configuration.
<code>show spanning-tree mst configuration digest</code>	Displays the MD5 digest included in the current MSTCI.
<code>show spanning-tree mst <i>instance-id</i></code>	Displays MST information for the specified instance.
<code>show spanning-tree mst interface <i>interface-id</i></code>	Displays MST information for the specified interface.

For information about other keywords for the **show spanning-tree** privileged EXEC command, see the command reference for this release.



CHAPTER 17

Configuring Optional Spanning-Tree Features

This chapter describes how to configure optional spanning-tree features on the Catalyst 2960 switch. You can configure all of these features when your switch is running the per-VLAN spanning-tree plus (PVST+). You can configure only the noted features when your switch is running the Multiple Spanning Tree Protocol (MSTP) or the rapid per-VLAN spanning-tree plus (rapid-PVST+) protocol.

For information on configuring the PVST+ and rapid PVST+, see [Chapter 15, “Configuring STP.”](#) For information about the Multiple Spanning Tree Protocol (MSTP) and how to map multiple VLANs to the same spanning-tree instance, see [Chapter 16, “Configuring MSTP.”](#)



Note

For complete syntax and usage information for the commands used in this chapter, see the command reference for this release.

This chapter consists of these sections:

- [Understanding Optional Spanning-Tree Features, page 17-1](#)
- [Configuring Optional Spanning-Tree Features, page 17-9](#)
- [Displaying the Spanning-Tree Status, page 17-16](#)

Understanding Optional Spanning-Tree Features

These sections contain this conceptual information:

- [Understanding Port Fast, page 17-2](#)
- [Understanding BPDU Guard, page 17-2](#)
- [Understanding BPDU Filtering, page 17-3](#)
- [Understanding UplinkFast, page 17-3](#)
- [Understanding BackboneFast, page 17-5](#)
- [Understanding EtherChannel Guard, page 17-7](#)
- [Understanding Root Guard, page 17-8](#)
- [Understanding Loop Guard, page 17-9](#)

Understanding Port Fast

Port Fast immediately brings an interface configured as an access or trunk port to the forwarding state from a blocking state, bypassing the listening and learning states. You can use Port Fast on interfaces connected to a single workstation or server, as shown in Figure 17-1, to allow those devices to immediately connect to the network, rather than waiting for the spanning tree to converge.

Interfaces connected to a single workstation or server should not receive bridge protocol data units (BPDUs). An interface with Port Fast enabled goes through the normal cycle of spanning-tree status changes when the switch is restarted.



Note

Because the purpose of Port Fast is to minimize the time interfaces must wait for spanning-tree to converge, it is effective only when used on interfaces connected to end stations. If you enable Port Fast on an interface connecting to another switch, you risk creating a spanning-tree loop.

You can enable this feature by using the **spanning-tree portfast** interface configuration or the **spanning-tree portfast default** global configuration command.

Figure 17-1 Port Fast-Enabled Interfaces

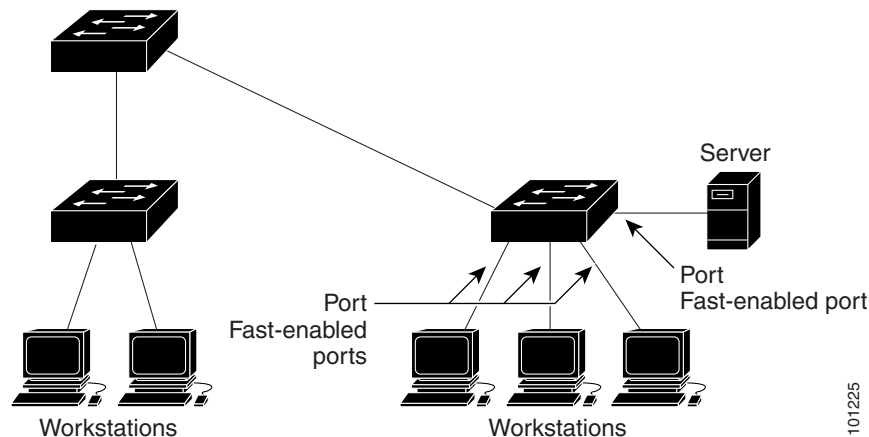

101225

Understanding BPDU Guard

The BPDU guard feature can be globally enabled on the switch or can be enabled per port, but the feature operates with some differences.

At the global level, you enable BPDU guard on Port Fast-enabled ports by using the **spanning-tree portfast bpduguard default** global configuration command. Spanning tree shuts down ports that are in a Port Fast-operational state if any BPDU is received on them. In a valid configuration, Port Fast-enabled ports do not receive BPDUs. Receiving a BPDU on a Port Fast-enabled port means an invalid configuration, such as the connection of an unauthorized device, and the BPDU guard feature puts the port in the error-disabled state. When this happens, the switch shuts down the entire port on which the violation occurred.

To prevent the port from shutting down, you can use the **errdisable detect cause bpduguard shutdown vlan** global configuration command to shut down just the offending VLAN on the port where the violation occurred.

At the interface level, you enable BPDU guard on any port by using the **spanning-tree bpduguard enable** interface configuration command without also enabling the Port Fast feature. When the port receives a BPDU, it is put in the error-disabled state.

The BPDU guard feature provides a secure response to invalid configurations because you must manually put the interface back in service. Use the BPDU guard feature in a service-provider network to prevent an access port from participating in the spanning tree.

Understanding BPDU Filtering

The BPDU filtering feature can be globally enabled on the switch or can be enabled per interface, but the feature operates with some differences.

At the global level, you can enable BPDU filtering on Port Fast-enabled interfaces by using the **spanning-tree portfast bpdupfilter default** global configuration command. This command prevents interfaces that are in a Port Fast-operational state from sending or receiving BPDUs. The interfaces still send a few BPDUs at link-up before the switch begins to filter outbound BPDUs. You should globally enable BPDU filtering on a switch so that hosts connected to these interfaces do not receive BPDUs. If a BPDU is received on a Port Fast-enabled interface, the interface loses its Port Fast-operational status, and BPDU filtering is disabled.

At the interface level, you can enable BPDU filtering on any interface by using the **spanning-tree bpdupfilter enable** interface configuration command without also enabling the Port Fast feature. This command prevents the interface from sending or receiving BPDUs.



Caution

Enabling BPDU filtering on an interface is the same as disabling spanning tree on it and can result in spanning-tree loops.

You can enable the BPDU filtering feature for the entire switch or for an interface.

Understanding UplinkFast

Switches in hierarchical networks can be grouped into backbone switches, distribution switches, and access switches. [Figure 17-2](#) shows a complex network where distribution switches and access switches each have at least one redundant link that spanning tree blocks to prevent loops.

Figure 17-2 Switches in a Hierarchical Network

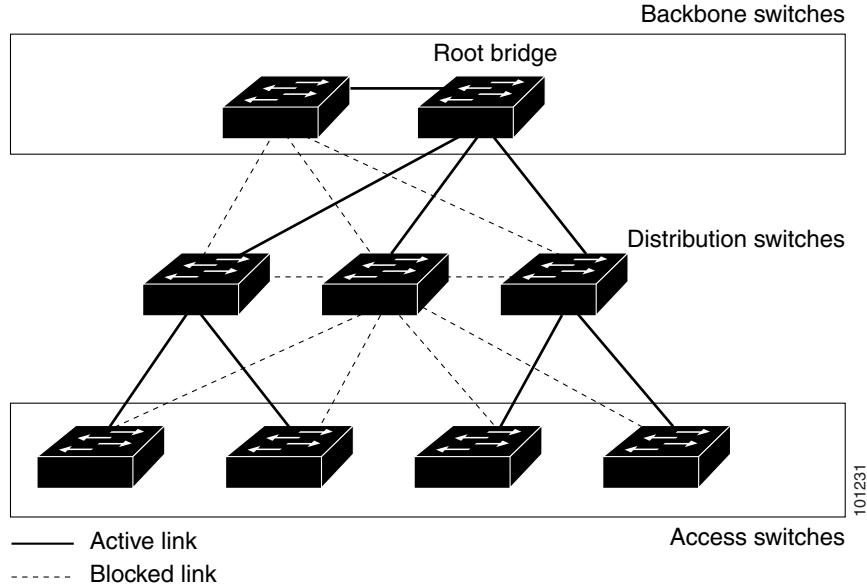

If a switch loses connectivity, it begins using the alternate paths as soon as the spanning tree selects a new root port. By enabling UplinkFast with the **spanning-tree uplinkfast** global configuration command, you can accelerate the choice of a new root port when a link or switch fails or when the spanning tree reconfigures itself. The root port transitions to the forwarding state immediately without going through the listening and learning states, as it would with the normal spanning-tree procedures.

When the spanning tree reconfigures the new root port, other interfaces flood the network with multicast packets, one for each address that was learned on the interface. You can limit these bursts of multicast traffic by reducing the max-update-rate parameter (the default for this parameter is 150 packets per second). However, if you enter zero, station-learning frames are not generated, so the spanning-tree topology converges more slowly after a loss of connectivity.

**Note**

UplinkFast is most useful in wiring-closet switches at the access or edge of the network. It is not appropriate for backbone devices. This feature might not be useful for other types of applications.

UplinkFast provides fast convergence after a direct link failure and achieves load balancing between redundant Layer 2 links using uplink groups. An uplink group is a set of Layer 2 interfaces (per VLAN), only one of which is forwarding at any given time. Specifically, an uplink group consists of the root port (which is forwarding) and a set of blocked ports, except for self-looping ports. The uplink group provides an alternate path in case the currently forwarding link fails.

Figure 17-3 shows an example topology with no link failures. Switch A, the root switch, is connected directly to Switch B over link L1 and to Switch C over link L2. The Layer 2 interface on Switch C that is connected directly to Switch B is in a blocking state.

Figure 17-3 UplinkFast Example Before Direct Link Failure

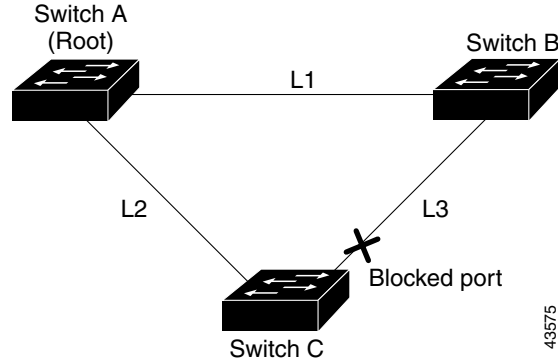

If Switch C detects a link failure on the currently active link L2 on the root port (a *direct* link failure), UplinkFast unblocks the blocked interface on Switch C and transitions it to the forwarding state without going through the listening and learning states, as shown in Figure 17-4. This change takes approximately 1 to 5 seconds.

Figure 17-4 UplinkFast Example After Direct Link Failure

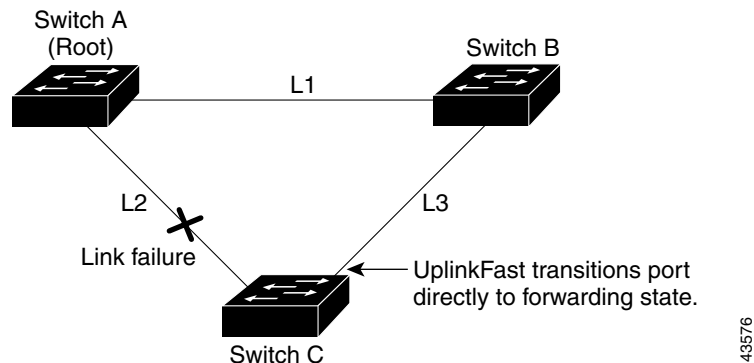

Understanding BackboneFast

BackboneFast detects indirect failures in the core of the backbone. BackboneFast is a complementary technology to the UplinkFast feature, which responds to failures on links directly connected to access switches. BackboneFast optimizes the maximum-age timer, which controls the amount of time the switch stores protocol information received on an interface. When a switch receives an inferior BPDU from the designated port of another switch, the BPDU is a signal that the other switch might have lost its path to the root, and BackboneFast tries to find an alternate path to the root.

BackboneFast, which is enabled by using the **spanning-tree backbonefast** global configuration command, starts when a root port or blocked interface on a switch receives inferior BPDUs from its designated switch. An inferior BPDU identifies a switch that declares itself as both the root bridge and the designated switch. When a switch receives an inferior BPDU, it means that a link to which the switch is not directly connected (an *indirect* link) has failed (that is, the designated switch has lost its connection to the root switch). Under spanning-tree rules, the switch ignores inferior BPDUs for the configured maximum aging time specified by the **spanning-tree vlan *vlan-id* max-age** global configuration command.

The switch tries to find if it has an alternate path to the root switch. If the inferior BPDU arrives on a blocked interface, the root port and other blocked interfaces on the switch become alternate paths to the root switch. (Self-looped ports are not considered alternate paths to the root switch.) If the inferior BPDU arrives on the root port, all blocked interfaces become alternate paths to the root switch. If the inferior BPDU arrives on the root port and there are no blocked interfaces, the switch assumes that it has lost connectivity to the root switch, causes the maximum aging time on the root port to expire, and becomes the root switch according to normal spanning-tree rules.

If the switch has alternate paths to the root switch, it uses these alternate paths to send a root link query (RLQ) request. The switch sends the RLQ request on all alternate paths and waits for an RLQ reply from other switches in the network.

If the switch discovers that it still has an alternate path to the root, it expires the maximum aging time on the interface that received the inferior BPDU. If all the alternate paths to the root switch indicate that the switch has lost connectivity to the root switch, the switch expires the maximum aging time on the interface that received the RLQ reply. If one or more alternate paths can still connect to the root switch, the switch makes all interfaces on which it received an inferior BPDU its designated ports and moves them from the blocking state (if they were in the blocking state), through the listening and learning states, and into the forwarding state.

Figure 17-5 shows an example topology with no link failures. Switch A, the root switch, connects directly to Switch B over link L1 and to Switch C over link L2. The Layer 2 interface on Switch C that connects directly to Switch B is in the blocking state.

Figure 17-5 BackboneFast Example Before Indirect Link Failure

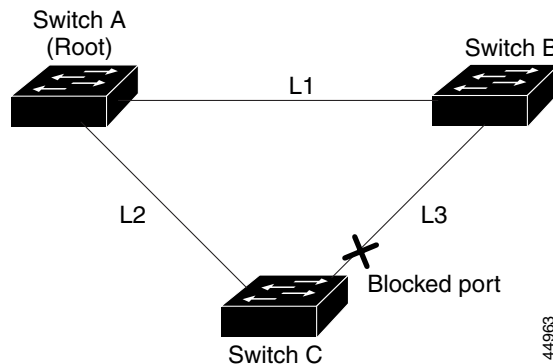

If link L1 fails as shown in Figure 17-6, Switch C cannot detect this failure because it is not connected directly to link L1. However, because Switch B is directly connected to the root switch over L1, it detects the failure, elects itself the root, and begins sending BPDUs to Switch C, identifying itself as the root. When Switch C receives the inferior BPDUs from Switch B, Switch C assumes that an indirect failure has occurred. At that point, BackboneFast allows the blocked interface on Switch C to move immediately to the listening state without waiting for the maximum aging time for the interface to expire. BackboneFast then transitions the Layer 2 interface on Switch C to the forwarding state, providing a path from Switch B to Switch A. The root-switch election takes approximately 30 seconds, twice the Forward Delay time if the default Forward Delay time of 15 seconds is set. Figure 17-6 shows how BackboneFast reconfigures the topology to account for the failure of link L1.

Figure 17-6 BackboneFast Example After Indirect Link Failure

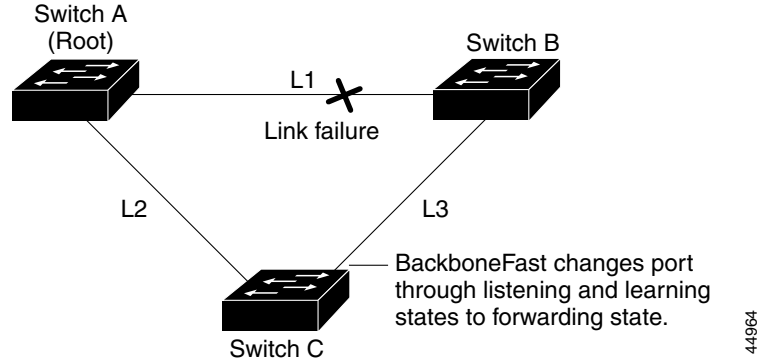

If a new switch is introduced into a shared-medium topology as shown in Figure 17-7, BackboneFast is not activated because the inferior BPDUs did not come from the recognized designated switch (Switch B). The new switch begins sending inferior BPDUs that indicate it is the root switch. However, the other switches ignore these inferior BPDUs, and the new switch learns that Switch B is the designated switch to Switch A, the root switch.

Figure 17-7 Adding a Switch in a Shared-Medium Topology

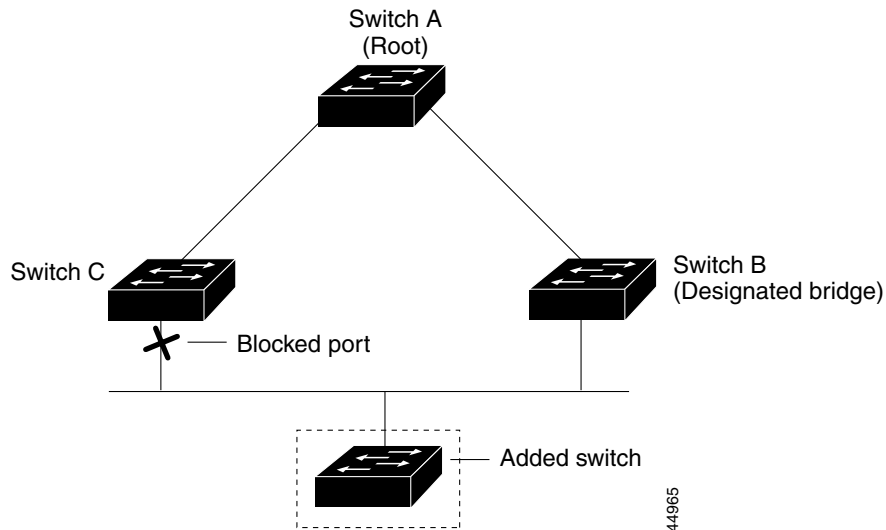

Understanding EtherChannel Guard

You can use EtherChannel guard to detect an EtherChannel misconfiguration between the switch and a connected device. A misconfiguration can occur if the switch interfaces are configured in an EtherChannel, but the interfaces on the other device are not. A misconfiguration can also occur if the channel parameters are not the same at both ends of the EtherChannel. For EtherChannel configuration guidelines, see the “[EtherChannel Configuration Guidelines](#)” section on page 31-9.

If the switch detects a misconfiguration on the other device, EtherChannel guard places the switch interfaces in the error-disabled state, and displays an error message.

You can enable this feature by using the `spanning-tree etherchannel guard misconfig` global configuration command.

Understanding Root Guard

The Layer 2 network of a service provider (SP) can include many connections to switches that are not owned by the SP. In such a topology, the spanning tree can reconfigure itself and select a *customer switch* as the root switch, as shown in Figure 17-8. You can avoid this situation by enabling root guard on SP switch interfaces that connect to switches in your customer's network. If spanning-tree calculations cause an interface in the customer network to be selected as the root port, root guard then places the interface in the root-inconsistent (blocked) state to prevent the customer's switch from becoming the root switch or being in the path to the root.

If a switch outside the SP network becomes the root switch, the interface is blocked (root-inconsistent state), and spanning tree selects a new root switch. The customer's switch does not become the root switch and is not in the path to the root.

If the switch is operating in multiple spanning-tree (MST) mode, root guard forces the interface to be a designated port. If a boundary port is blocked in an internal spanning-tree (IST) instance because of root guard, the interface also is blocked in all MST instances. A boundary port is an interface that connects to a LAN, the designated switch of which is either an IEEE 802.1D switch or a switch with a different MST region configuration.

Root guard enabled on an interface applies to all the VLANs to which the interface belongs. VLANs can be grouped and mapped to an MST instance.

You can enable this feature by using the **spanning-tree guard root** interface configuration command.



Caution

Misuse of the root-guard feature can cause a loss of connectivity.

Figure 17-8 Root Guard in a Service-Provider Network

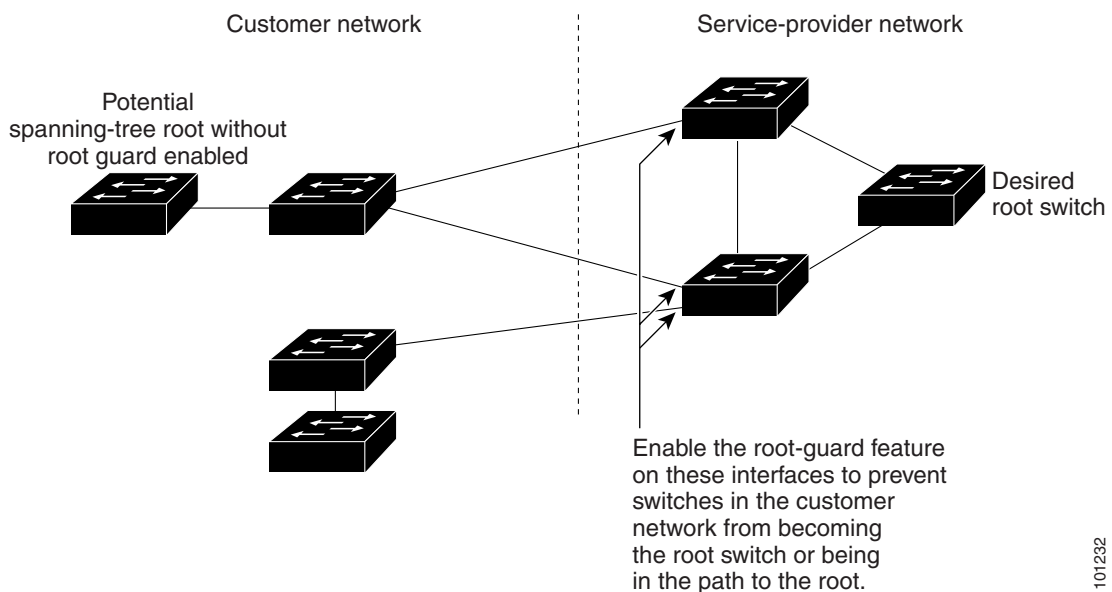

Understanding Loop Guard

You can use loop guard to prevent alternate or root ports from becoming designated ports because of a failure that leads to a unidirectional link. This feature is most effective when it is enabled on the entire switched network. Loop guard prevents alternate and root ports from becoming designated ports, and spanning tree does not send BPDUs on root or alternate ports.

You can enable this feature by using the **spanning-tree loopguard default** global configuration command.

When the switch is operating in PVST+ or rapid-PVST+ mode, loop guard prevents alternate and root ports from becoming designated ports, and spanning tree does not send BPDUs on root or alternate ports.

When the switch is operating in MST mode, BPDUs are not sent on nonboundary ports only if the interface is blocked by loop guard in all MST instances. On a boundary port, loop guard blocks the interface in all MST instances.

Configuring Optional Spanning-Tree Features

These sections contain this configuration information:

- [Default Optional Spanning-Tree Configuration, page 17-9](#)
- [Optional Spanning-Tree Configuration Guidelines, page 17-10](#)
- [Enabling Port Fast, page 17-10](#) (optional)
- [Enabling BPDU Guard, page 17-11](#) (optional)
- [Enabling BPDU Filtering, page 17-12](#) (optional)
- [Enabling UplinkFast for Use with Redundant Links, page 17-13](#) (optional)
- [Enabling BackboneFast, page 17-13](#) (optional)
- [Enabling EtherChannel Guard, page 17-14](#) (optional)
- [Enabling Root Guard, page 17-15](#) (optional)
- [Enabling Loop Guard, page 17-15](#) (optional)

Default Optional Spanning-Tree Configuration

[Table 17-1](#) shows the default optional spanning-tree configuration.

Table 17-1 *Default Optional Spanning-Tree Configuration*

Feature	Default Setting
Port Fast, BPDU filtering, BPDU guard	Globally disabled (unless they are individually configured per interface).
UplinkFast	Globally disabled.
BackboneFast	Globally disabled.
EtherChannel guard	Globally enabled.
Root guard	Disabled on all interfaces.
Loop guard	Disabled on all interfaces.

Optional Spanning-Tree Configuration Guidelines

You can configure PortFast, BPDU guard, BPDU filtering, EtherChannel guard, root guard, or loop guard if your switch is running PVST+, rapid PVST+, or MSTP.

You can configure the UplinkFast or the BackboneFast feature for rapid PVST+ or for the MSTP, but the feature remains disabled (inactive) until you change the spanning-tree mode to PVST+.

Enabling Port Fast

An interface with the Port Fast feature enabled is moved directly to the spanning-tree forwarding state without waiting for the standard forward-time delay.



Caution

Use Port Fast *only* when connecting a single end station to an access or trunk port. Enabling this feature on an interface connected to a switch or hub could prevent spanning tree from detecting and disabling loops in your network, which could cause broadcast storms and address-learning problems.

If you enable the voice VLAN feature, the Port Fast feature is automatically enabled. When you disable voice VLAN, the Port Fast feature is not automatically disabled. For more information, see [Chapter 14, “Configuring Voice VLAN.”](#)

You can enable this feature if your switch is running PVST+, rapid PVST+, or MSTP.

Beginning in privileged EXEC mode, follow these steps to enable Port Fast. This procedure is optional.

	Command	Purpose
Step 1	<code>configure terminal</code>	Enter global configuration mode.
Step 2	<code>interface interface-id</code>	Specify an interface to configure, and enter interface configuration mode.
Step 3	<code>spanning-tree portfast [trunk]</code>	<p>Enable Port Fast on an access port connected to a single workstation or server. By specifying the trunk keyword, you can enable Port Fast on a trunk port.</p> <p>Note To enable Port Fast on trunk ports, you must use the spanning-tree portfast trunk interface configuration command. The spanning-tree portfast command will not work on trunk ports.</p> <p> Caution Make sure that there are no loops in the network between the trunk port and the workstation or server before you enable Port Fast on a trunk port.</p> <p>By default, Port Fast is disabled on all interfaces.</p>
Step 4	<code>end</code>	Return to privileged EXEC mode.
Step 5	<code>show spanning-tree interface interface-id portfast</code>	Verify your entries.
Step 6	<code>copy running-config startup-config</code>	(Optional) Save your entries in the configuration file.

**Note**

You can use the **spanning-tree portfast default** global configuration command to globally enable the Port Fast feature on all nontrunking ports.

To disable the Port Fast feature, use the **spanning-tree portfast disable** interface configuration command.

Enabling BPDU Guard

When you globally enable BPDU guard on ports that are Port Fast-enabled (the ports are in a Port Fast-operational state), spanning tree shuts down Port Fast-enabled ports that receive BPDUs.

In a valid configuration, Port Fast-enabled ports do not receive BPDUs. Receiving a BPDU on a Port Fast-enabled port means an invalid configuration, such as the connection of an unauthorized device, and the BPDU guard feature puts the port in the error-disabled state. When this happens, the switch shuts down the entire port on which the violation occurred.

To prevent the port from shutting down, you can use the **errdisable detect cause bpduguard shutdown vlan** global configuration command to shut down just the offending VLAN on the port where the violation occurred.

The BPDU guard feature provides a secure response to invalid configurations because you must manually put the port back in service. Use the BPDU guard feature in a service-provider network to prevent an access port from participating in the spanning tree.

**Caution**

Configure Port Fast only on ports that connect to end stations; otherwise, an accidental topology loop could cause a data packet loop and disrupt switch and network operation.

You also can use the **spanning-tree bpduguard enable** interface configuration command to enable BPDU guard on any port without also enabling the Port Fast feature. When the port receives a BPDU, it is put in the error-disabled state.

You can enable the BPDU guard feature if your switch is running PVST+, rapid PVST+, or MSTP.

Beginning in privileged EXEC mode, follow these steps to globally enable the BPDU guard feature. This procedure is optional.

	Command	Purpose
Step 1	configure terminal	Enter global configuration mode.
Step 2	spanning-tree portfast bpduguard default	Globally enable BPDU guard. By default, BPDU guard is disabled.
Step 3	interface <i>interface-id</i>	Specify the interface connected to an end station, and enter interface configuration mode.
Step 4	spanning-tree portfast	Enable the Port Fast feature.
Step 5	end	Return to privileged EXEC mode.
Step 6	show running-config	Verify your entries.
Step 7	copy running-config startup-config	(Optional) Save your entries in the configuration file.

To disable BPDU guard, use the **no spanning-tree portfast bpduguard default** global configuration command.

You can override the setting of the **no spanning-tree portfast bpduguard default** global configuration command by using the **spanning-tree bpduguard enable** interface configuration command.

Enabling BPDU Filtering

When you globally enable BPDU filtering on Port Fast-enabled interfaces, it prevents interfaces that are in a Port Fast-operational state from sending or receiving BPDUs. The interfaces still send a few BPDUs at link-up before the switch begins to filter outbound BPDUs. You should globally enable BPDU filtering on a switch so that hosts connected to these interfaces do not receive BPDUs. If a BPDU is received on a Port Fast-enabled interface, the interface loses its Port Fast-operational status, and BPDU filtering is disabled.



Caution

Configure Port Fast only on interfaces that connect to end stations; otherwise, an accidental topology loop could cause a data packet loop and disrupt switch and network operation.

You can also use the **spanning-tree bpdudfilter enable** interface configuration command to enable BPDU filtering on any interface without also enabling the Port Fast feature. This command prevents the interface from sending or receiving BPDUs.



Caution

Enabling BPDU filtering on an interface is the same as disabling spanning tree on it and can result in spanning-tree loops.

You can enable the BPDU filtering feature if your switch is running PVST+, rapid PVST+, or MSTP.

Beginning in privileged EXEC mode, follow these steps to globally enable the BPDU filtering feature. This procedure is optional.

	Command	Purpose
Step 1	configure terminal	Enter global configuration mode.
Step 2	spanning-tree portfast bpdudfilter default	Globally enable BPDU filtering. By default, BPDU filtering is disabled.
Step 3	interface <i>interface-id</i>	Specify the interface connected to an end station, and enter interface configuration mode.
Step 4	spanning-tree portfast	Enable the Port Fast feature.
Step 5	end	Return to privileged EXEC mode.
Step 6	show running-config	Verify your entries.
Step 7	copy running-config startup-config	(Optional) Save your entries in the configuration file.

To disable BPDU filtering, use the **no spanning-tree portfast bpdudfilter default** global configuration command.

You can override the setting of the **no spanning-tree portfast bpdudfilter default** global configuration command by using the **spanning-tree bpdudfilter enable** interface configuration command.

Enabling UplinkFast for Use with Redundant Links

UplinkFast cannot be enabled on VLANs that have been configured with a switch priority. To enable UplinkFast on a VLAN with switch priority configured, first restore the switch priority on the VLAN to the default value by using the **no spanning-tree vlan *vlan-id* priority** global configuration command.



Note

When you enable UplinkFast, it affects all VLANs on the switch. You cannot configure UplinkFast on an individual VLAN.

You can configure the UplinkFast feature for rapid PVST+ or for the MSTP, but the feature remains disabled (inactive) until you change the spanning-tree mode to PVST+.

Beginning in privileged EXEC mode, follow these steps to enable UplinkFast. This procedure is optional.

	Command	Purpose
Step 1	configure terminal	Enter global configuration mode.
Step 2	spanning-tree uplinkfast [max-update-rate <i>pkts-per-second</i>]	Enable UplinkFast. (Optional) For <i>pkts-per-second</i> , the range is 0 to 32000 packets per second; the default is 150. If you set the rate to 0, station-learning frames are not generated, and the spanning-tree topology converges more slowly after a loss of connectivity.
Step 3	end	Return to privileged EXEC mode.
Step 4	show spanning-tree summary	Verify your entries.
Step 5	copy running-config startup-config	(Optional) Save your entries in the configuration file.

When UplinkFast is enabled, the switch priority of all VLANs is set to 49152. If you change the path cost to a value less than 3000 and you enable UplinkFast or UplinkFast is already enabled, the path cost of all interfaces and VLAN trunks is increased by 3000 (if you change the path cost to 3000 or above, the path cost is not altered). The changes to the switch priority and the path cost reduce the chance that a switch will become the root switch.

When UplinkFast is disabled, the switch priorities of all VLANs and path costs of all interfaces are set to default values if you did not modify them from their defaults.

To return the update packet rate to the default setting, use the **no spanning-tree uplinkfast max-update-rate** global configuration command. To disable UplinkFast, use the **no spanning-tree uplinkfast** command.

Enabling BackboneFast

You can enable BackboneFast to detect indirect link failures and to start the spanning-tree reconfiguration sooner.



Note

If you use BackboneFast, you must enable it on all switches in the network. BackboneFast is not supported on Token Ring VLANs. This feature is supported for use with third-party switches.

You can configure the BackboneFast feature for rapid PVST+ or for the MSTP, but the feature remains disabled (inactive) until you change the spanning-tree mode to PVST+.

Beginning in privileged EXEC mode, follow these steps to enable BackboneFast. This procedure is optional.

	Command	Purpose
Step 1	configure terminal	Enter global configuration mode.
Step 2	spanning-tree backbonefast	Enable BackboneFast.
Step 3	end	Return to privileged EXEC mode.
Step 4	show spanning-tree summary	Verify your entries.
Step 5	copy running-config startup-config	(Optional) Save your entries in the configuration file.

To disable the BackboneFast feature, use the **no spanning-tree backbonefast** global configuration command.

Enabling EtherChannel Guard

You can enable EtherChannel guard to detect an EtherChannel misconfiguration if your switch is running PVST+, rapid PVST+, or MSTP.

Beginning in privileged EXEC mode, follow these steps to enable EtherChannel guard. This procedure is optional.

	Command	Purpose
Step 1	configure terminal	Enter global configuration mode.
Step 2	spanning-tree etherchannel guard misconfig	Enable EtherChannel guard.
Step 3	end	Return to privileged EXEC mode.
Step 4	show spanning-tree summary	Verify your entries.
Step 5	copy running-config startup-config	(Optional) Save your entries in the configuration file.

To disable the EtherChannel guard feature, use the **no spanning-tree etherchannel guard misconfig** global configuration command.

You can use the **show interfaces status err-disabled** privileged EXEC command to show which switch ports are disabled because of an EtherChannel misconfiguration. On the remote device, you can enter the **show etherchannel summary** privileged EXEC command to verify the EtherChannel configuration.

After the configuration is corrected, enter the **shutdown** and **no shutdown** interface configuration commands on the port-channel interfaces that were misconfigured.

Enabling Root Guard

Root guard enabled on an interface applies to all the VLANs to which the interface belongs. Do not enable the root guard on interfaces to be used by the UplinkFast feature. With UplinkFast, the backup interfaces (in the blocked state) replace the root port in the case of a failure. However, if root guard is also enabled, all the backup interfaces used by the UplinkFast feature are placed in the root-inconsistent state (blocked) and are prevented from reaching the forwarding state.

Note

You cannot enable both root guard and loop guard at the same time.

You can enable this feature if your switch is running PVST+, rapid PVST+, or MSTP.

Beginning in privileged EXEC mode, follow these steps to enable root guard on an interface. This procedure is optional.

	Command	Purpose
Step 1	configure terminal	Enter global configuration mode.
Step 2	interface <i>interface-id</i>	Specify an interface to configure, and enter interface configuration mode.
Step 3	spanning-tree guard root	Enable root guard on the interface. By default, root guard is disabled on all interfaces.
Step 4	end	Return to privileged EXEC mode.
Step 5	show running-config	Verify your entries.
Step 6	copy running-config startup-config	(Optional) Save your entries in the configuration file.

To disable root guard, use the **no spanning-tree guard** interface configuration command.

Enabling Loop Guard

You can use loop guard to prevent alternate or root ports from becoming designated ports because of a failure that leads to a unidirectional link. This feature is most effective when it is configured on the entire switched network. Loop guard operates only on interfaces that are considered point-to-point by the spanning tree.

Note

You cannot enable both loop guard and root guard at the same time.

You can enable this feature if your switch is running PVST+, rapid PVST+, or MSTP.

Beginning in privileged EXEC mode, follow these steps to enable loop guard. This procedure is optional.

	Command	Purpose
Step 1	show spanning-tree active or show spanning-tree mst	Verify which interfaces are alternate or root ports.
Step 2	configure terminal	Enter global configuration mode.

	Command	Purpose
Step 3	spanning-tree loopguard default	Enable loop guard. By default, loop guard is disabled.
Step 4	end	Return to privileged EXEC mode.
Step 5	show running-config	Verify your entries.
Step 6	copy running-config startup-config	(Optional) Save your entries in the configuration file.

To globally disable loop guard, use the **no spanning-tree loopguard default** global configuration command. You can override the setting of the **no spanning-tree loopguard default** global configuration command by using the **spanning-tree guard loop** interface configuration command.

Displaying the Spanning-Tree Status

To display the spanning-tree status, use one or more of the privileged EXEC commands in [Table 17-2](#):

Table 17-2 Commands for Displaying the Spanning-Tree Status

Command	Purpose
show spanning-tree active	Displays spanning-tree information on active interfaces only.
show spanning-tree detail	Displays a detailed summary of interface information.
show spanning-tree interface <i>interface-id</i>	Displays spanning-tree information for the specified interface.
show spanning-tree mst interface <i>interface-id</i>	Displays MST information for the specified interface.
show spanning-tree summary [totals]	Displays a summary of interface states or displays the total lines of the spanning-tree state section.

You can clear spanning-tree counters by using the **clear spanning-tree [interface interface-id]** privileged EXEC command.

For information about other keywords for the **show spanning-tree** privileged EXEC command, see the command reference for this release.



CHAPTER 18

Configuring IGMP Snooping and MVR

This chapter describes how to configure Internet Group Management Protocol (IGMP) snooping on the Catalyst 2960 switch, including an application of local IGMP snooping, Multicast VLAN Registration (MVR). It also includes procedures for controlling multicast group membership by using IGMP filtering and procedures for configuring the IGMP throttling action.



Note

For complete syntax and usage information for the commands used in this chapter, see the switch command reference for this release and the “IP Multicast Routing Commands” section in the *Cisco IOS IP Command Reference, Volume 3 of 3: Multicast, Release 12.2* from the Cisco.com page under **Documentation > Cisco IOS Software > 12.2 Mainline > Command References**.

This chapter consists of these sections:

- [Understanding IGMP Snooping, page 18-1](#)
- [Configuring IGMP Snooping, page 18-6](#)
- [Displaying IGMP Snooping Information, page 18-15](#)
- [Understanding Multicast VLAN Registration, page 18-17](#)
- [Configuring MVR, page 18-19](#)
- [Displaying MVR Information, page 18-23](#)
- [Configuring IGMP Filtering and Throttling, page 18-23](#)
- [Displaying IGMP Filtering and Throttling Configuration, page 18-28](#)



Note

You can either manage IP multicast group addresses through features such as IGMP snooping and MVR, or you can use static IP addresses.

Understanding IGMP Snooping

Layer 2 switches can use IGMP snooping to constrain the flooding of multicast traffic by dynamically configuring Layer 2 interfaces so that multicast traffic is forwarded to only those interfaces associated with IP multicast devices. As the name implies, IGMP snooping requires the LAN switch to snoop on the IGMP transmissions between the host and the router and to keep track of multicast groups and member ports. When the switch receives an IGMP report from a host for a particular multicast group,

the switch adds the host port number to the forwarding table entry; when it receives an IGMP Leave Group message from a host, it removes the host port from the table entry. It also periodically deletes entries if it does not receive IGMP membership reports from the multicast clients.

**Note**

For more information on IP multicast and IGMP, see RFC 1112 and RFC 2236.

The multicast router sends out periodic general queries to all VLANs. All hosts interested in this multicast traffic send join requests and are added to the forwarding table entry. The switch creates one entry per VLAN in the IGMP snooping IP multicast forwarding table for each group from which it receives an IGMP join request.

The switch supports IP multicast group-based bridging, rather than MAC-addressed based groups. With multicast MAC address-based groups, if an IP address being configured translates (aliases) to a previously configured MAC address or to any reserved multicast MAC addresses (in the range 224.0.0.xxx), the command fails. Because the switch uses IP multicast groups, there are no address aliasing issues.

The IP multicast groups learned through IGMP snooping are dynamic. However, you can statically configure multicast groups by using the **ip igmp snooping vlan *vlan-id* static *ip_address* interface *interface-id*** global configuration command. If you specify group membership for a multicast group address statically, your setting supersedes any automatic manipulation by IGMP snooping. Multicast group membership lists can consist of both user-defined and IGMP snooping-learned settings.

You can configure an IGMP snooping querier to support IGMP snooping in subnets without multicast interfaces because the multicast traffic does not need to be routed. For more information about the IGMP snooping querier, see the “[Configuring the IGMP Snooping Querier](#)” section on page 18-14.

If a port spanning-tree, a port group, or a VLAN ID change occurs, the IGMP snooping-learned multicast groups from this port on the VLAN are deleted.

These sections describe IGMP snooping characteristics:

- [IGMP Versions, page 18-2](#)
- [Joining a Multicast Group, page 18-3](#)
- [Leaving a Multicast Group, page 18-5](#)
- [Immediate Leave, page 18-5](#)
- [IGMP Configurable-Leave Timer, page 18-5](#)
- [IGMP Report Suppression, page 18-6](#)

IGMP Versions

The switch supports IGMP Version 1, IGMP Version 2, and IGMP Version 3. These versions are interoperable on the switch. For example, if IGMP snooping is enabled on an IGMPv2 switch and the switch receives an IGMPv3 report from a host, the switch can forward the IGMPv3 report to the multicast router.

**Note**

The switch supports IGMPv3 snooping based only on the destination multicast MAC address. It does not support snooping based on the source MAC address or on proxy reports.

An IGMPv3 switch supports Basic IGMPv3 Snooping Support (BISS), which includes support for the snooping features on IGMPv1 and IGMPv2 switches and for IGMPv3 membership report messages. BISS constrains the flooding of multicast traffic when your network includes IGMPv3 hosts. It constrains traffic to approximately the same set of ports as the IGMP snooping feature on IGMPv2 or IGMPv1 hosts.

**Note**

IGMPv3 join and leave messages are not supported on switches running IGMP filtering or MVR.

An IGMPv3 switch can receive messages from and forward messages to a device running the Source Specific Multicast (SSM) feature. For more information about source-specific multicast with IGMPv3 and IGMP, see the following URL:

http://www.cisco.com/en/US/products/sw/iosswrel/ps1834/products_feature_guide09186a008008048a.html

Joining a Multicast Group

When a host connected to the switch wants to join an IP multicast group and it is an IGMP Version 2 client, it sends an unsolicited IGMP join message, specifying the IP multicast group to join. Alternatively, when the switch receives a general query from the router, it forwards the query to all ports in the VLAN. IGMP Version 1 or Version 2 hosts wanting to join the multicast group respond by sending a join message to the switch. The switch CPU creates a multicast forwarding-table entry for the group if it is not already present. The CPU also adds the interface where the join message was received to the forwarding-table entry. The host associated with that interface receives multicast traffic for that multicast group. See [Figure 18-1](#).

Figure 18-1 Initial IGMP Join Message

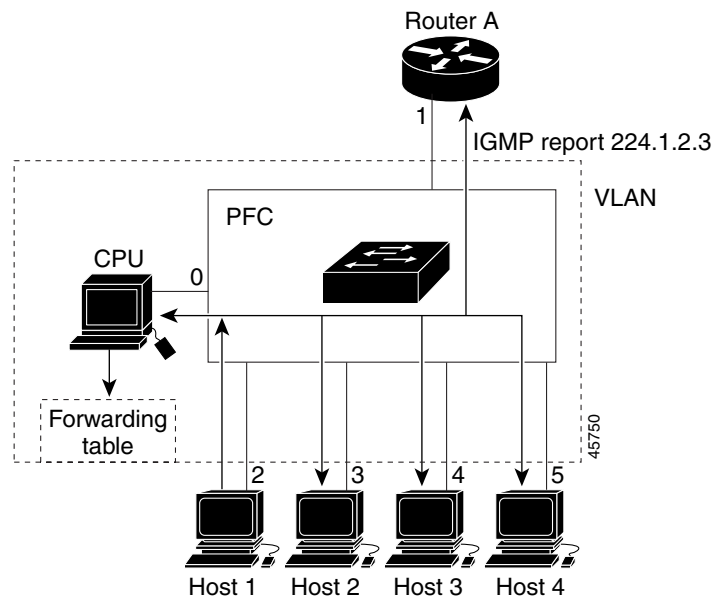

Router A sends a general query to the switch, which forwards the query to ports 2 through 5, which are all members of the same VLAN. Host 1 wants to join multicast group 224.1.2.3 and multicasts an IGMP membership report (IGMP join message) to the group. The switch CPU uses the information in the IGMP report to set up a forwarding-table entry, as shown in [Table 18-1](#), that includes the port numbers connected to Host 1 and the router.

Table 18-1 IGMP Snooping Forwarding Table

Destination Address	Type of Packet	Ports
224.1.2.3	IGMP	1, 2

The switch hardware can distinguish IGMP information packets from other packets for the multicast group. The information in the table tells the switching engine to send frames addressed to the 224.1.2.3 multicast IP address that are not IGMP packets to the router and to the host that has joined the group.

If another host (for example, Host 4) sends an unsolicited IGMP join message for the same group ([Figure 18-2](#)), the CPU receives that message and adds the port number of Host 4 to the forwarding table as shown in [Table 18-2](#). Note that because the forwarding table directs IGMP messages only to the CPU, the message is not flooded to other ports on the switch. Any known multicast traffic is forwarded to the group and not to the CPU.

Figure 18-2 Second Host Joining a Multicast Group

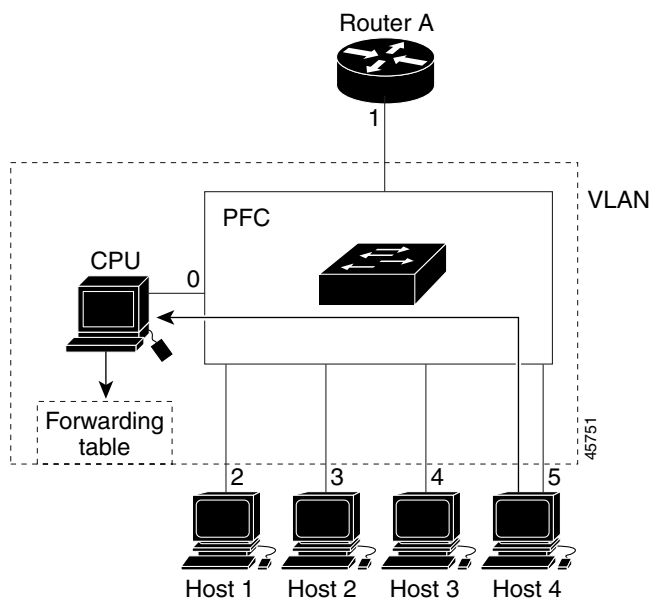

Table 18-2 Updated IGMP Snooping Forwarding Table

Destination Address	Type of Packet	Ports
224.1.2.3	IGMP	1, 2, 5

Leaving a Multicast Group

The router sends periodic multicast general queries, and the switch forwards these queries through all ports in the VLAN. Interested hosts respond to the queries. If at least one host in the VLAN wishes to receive multicast traffic, the router continues forwarding the multicast traffic to the VLAN. The switch forwards multicast group traffic only to those hosts listed in the forwarding table for that IP multicast group maintained by IGMP snooping.

When hosts want to leave a multicast group, they can silently leave, or they can send a leave message. When the switch receives a leave message from a host, it sends a group-specific query to learn if any other devices connected to that interface are interested in traffic for the specific multicast group. The switch then updates the forwarding table for that MAC group so that only those hosts interested in receiving multicast traffic for the group are listed in the forwarding table. If the router receives no reports from a VLAN, it removes the group for the VLAN from its IGMP cache.

Immediate Leave

Immediate Leave is only supported on IGMP Version 2 hosts.

The switch uses IGMP snooping Immediate Leave to remove from the forwarding table an interface that sends a leave message without the switch sending group-specific queries to the interface. The VLAN interface is pruned from the multicast tree for the multicast group specified in the original leave message. Immediate Leave ensures optimal bandwidth management for all hosts on a switched network, even when multiple multicast groups are simultaneously in use.

**Note**

You should only use the Immediate Leave feature on VLANs where a single host is connected to each port. If Immediate Leave is enabled in VLANs where more than one host is connected to a port, some hosts might inadvertently be dropped.

For configuration steps, see the [“Enabling IGMP Immediate Leave”](#) section on page 18-10.

IGMP Configurable-Leave Timer

You can configure the time that the switch waits after sending a group-specific query to determine if hosts are still interested in a specific multicast group. The IGMP leave response time can be configured from 100 to 5000 milliseconds. The timer can be set either globally or on a per-VLAN basis. The VLAN configuration of the leave time overrides the global configuration.

For configuration steps, see the [“Configuring the IGMP Leave Timer”](#) section on page 18-11.

IGMP Report Suppression



Note

IGMP report suppression is supported only when the multicast query has IGMPv1 and IGMPv2 reports. This feature is not supported when the query includes IGMPv3 reports.

The switch uses IGMP report suppression to forward only one IGMP report per multicast router query to multicast devices. When IGMP router suppression is enabled (the default), the switch sends the first IGMP report from all hosts for a group to all the multicast routers. The switch does not send the remaining IGMP reports for the group to the multicast routers. This feature prevents duplicate reports from being sent to the multicast devices.

If the multicast router query includes requests only for IGMPv1 and IGMPv2 reports, the switch forwards only the first IGMPv1 or IGMPv2 report from all hosts for a group to all the multicast routers.

If the multicast router query also includes requests for IGMPv3 reports, the switch forwards all IGMPv1, IGMPv2, and IGMPv3 reports for a group to the multicast devices.

If you disable IGMP report suppression, all IGMP reports are forwarded to the multicast routers. For configuration steps, see the [“Disabling IGMP Report Suppression”](#) section on page 18-15.

Configuring IGMP Snooping

IGMP snooping allows switches to examine IGMP packets and make forwarding decisions based on their content. These sections contain this configuration information:

- [Default IGMP Snooping Configuration, page 18-6](#)
- [Enabling or Disabling IGMP Snooping, page 18-7](#)
- [Setting the Snooping Method, page 18-8](#)
- [Configuring a Multicast Router Port, page 18-9](#)
- [Configuring a Host Statically to Join a Group, page 18-10](#)
- [Enabling IGMP Immediate Leave, page 18-10](#)
- [Configuring the IGMP Leave Timer, page 18-11](#)
- [Configuring TCN-Related Commands, page 18-12](#)
- [Configuring the IGMP Snooping Querier, page 18-14](#)
- [Disabling IGMP Report Suppression, page 18-15](#)

Default IGMP Snooping Configuration

Table 18-3 shows the default IGMP snooping configuration.

Table 18-3 Default IGMP Snooping Configuration

Feature	Default Setting
IGMP snooping	Enabled globally and per VLAN
Multicast routers	None configured

Table 18-3 Default IGMP Snooping Configuration (continued)

Feature	Default Setting
Multicast router learning (snooping) method	PIM-DVMRP
IGMP snooping Immediate Leave	Disabled
Static groups	None configured
TCN ¹ flood query count	2
TCN query solicitation	Disabled
IGMP snooping querier	Disabled
IGMP report suppression	Enabled

1. TCN = Topology Change Notification

Enabling or Disabling IGMP Snooping

By default, IGMP snooping is globally enabled on the switch. When globally enabled or disabled, it is also enabled or disabled in all existing VLAN interfaces. IGMP snooping is by default enabled on all VLANs, but can be enabled and disabled on a per-VLAN basis.

Global IGMP snooping overrides the VLAN IGMP snooping. If global snooping is disabled, you cannot enable VLAN snooping. If global snooping is enabled, you can enable or disable VLAN snooping.

Beginning in privileged EXEC mode, follow these steps to globally enable IGMP snooping on the switch:

	Command	Purpose
Step 1	configure terminal	Enter global configuration mode.
Step 2	ip igmp snooping	Globally enable IGMP snooping in all existing VLAN interfaces.
Step 3	end	Return to privileged EXEC mode.
Step 4	copy running-config startup-config	(Optional) Save your entries in the configuration file.

To globally disable IGMP snooping on all VLAN interfaces, use the **no ip igmp snooping** global configuration command.

Beginning in privileged EXEC mode, follow these steps to enable IGMP snooping on a VLAN interface:

	Command	Purpose
Step 1	configure terminal	Enter global configuration mode.
Step 2	ip igmp snooping vlan <i>vlan-id</i>	Enable IGMP snooping on the VLAN interface. The VLAN ID range is 1 to 1001 and 1006 to 4094. Note IGMP snooping must be globally enabled before you can enable VLAN snooping.

	Command	Purpose
Step 3	end	Return to privileged EXEC mode.
Step 4	copy running-config startup-config	(Optional) Save your entries in the configuration file.

To disable IGMP snooping on a VLAN interface, use the **no ip igmp snooping vlan *vlan-id*** global configuration command for the specified VLAN number.

Setting the Snooping Method

Multicast-capable router ports are added to the forwarding table for every Layer 2 multicast entry. The switch learns of such ports through one of these methods:

- Snooping on IGMP queries, Protocol Independent Multicast (PIM) packets, and Distance Vector Multicast Routing Protocol (DVMRP) packets
- Listening to Cisco Group Management Protocol (CGMP) packets from other routers
- Statically connecting to a multicast router port with the **ip igmp snooping mrouter** global configuration command

You can configure the switch either to snoop on IGMP queries and PIM/DVMRP packets or to listen to CGMP self-join or proxy-join packets. By default, the switch snoops on PIM/DVMRP packets on all VLANs. To learn of multicast router ports through only CGMP packets, use the **ip igmp snooping vlan *vlan-id* mrouter learn cgmp** global configuration command. When this command is entered, the router listens to only CGMP self-join and CGMP proxy-join packets and to no other CGMP packets. To learn of multicast router ports through only PIM-DVMRP packets, use the **ip igmp snooping vlan *vlan-id* mrouter learn pim-dvmrp** global configuration command.



Note

If you want to use CGMP as the learning method and no multicast routers in the VLAN are CGMP proxy-enabled, you must enter the **ip cgmp router-only** command to dynamically access the router.

Beginning in privileged EXEC mode, follow these steps to alter the method in which a VLAN interface dynamically accesses a multicast router:

	Command	Purpose
Step 1	configure terminal	Enter global configuration mode.
Step 2	ip igmp snooping vlan <i>vlan-id</i> mrouter learn {cgmp pim-dvmrp}	Enable IGMP snooping on a VLAN. The VLAN ID range is 1 to 1001 and 1006 to 4094. Specify the multicast router learning method: <ul style="list-style-type: none"> • cgmp—Listen for CGMP packets. This method is useful for reducing control traffic. • pim-dvmrp—Snoop on IGMP queries and PIM-DVMRP packets. This is the default.
Step 3	end	Return to privileged EXEC mode.
Step 4	show ip igmp snooping	Verify the configuration.
Step 5	copy running-config startup-config	(Optional) Save your entries in the configuration file.

To return to the default learning method, use the **no ip igmp snooping vlan *vlan-id* mrouter learn cgmp** global configuration command.

This example shows how to configure IGMP snooping to use CGMP packets as the learning method:

```
Switch# configure terminal
Switch(config)# ip igmp snooping vlan 1 mrouter learn cgmp
Switch(config)# end
```

Configuring a Multicast Router Port

To add a multicast router port (add a static connection to a multicast router), use the **ip igmp snooping vlan mrouter** global configuration command on the switch.

Beginning in privileged EXEC mode, follow these steps to enable a static connection to a multicast router:

	Command	Purpose
Step 1	configure terminal	Enter global configuration mode.
Step 2	ip igmp snooping vlan <i>vlan-id</i> mrouter interface <i>interface-id</i>	Specify the multicast router VLAN ID and the interface to the multicast router. <ul style="list-style-type: none"> The VLAN ID range is 1 to 1001 and 1006 to 4094. The interface can be a physical interface or a port channel. The port-channel range is 1 to 6.
Step 3	end	Return to privileged EXEC mode.
Step 4	show ip igmp snooping mrouter [vlan <i>vlan-id</i>]	Verify that IGMP snooping is enabled on the VLAN interface.
Step 5	copy running-config startup-config	(Optional) Save your entries in the configuration file.

To remove a multicast router port from the VLAN, use the **no ip igmp snooping vlan *vlan-id* mrouter interface *interface-id*** global configuration command.

This example shows how to enable a static connection to a multicast router:

```
Switch# configure terminal
Switch(config)# ip igmp snooping vlan 200 mrouter interface gigabitethernet0/2
Switch(config)# end
```

Configuring a Host Statically to Join a Group

Hosts or Layer 2 ports normally join multicast groups dynamically, but you can also statically configure a host on an interface.

Beginning in privileged EXEC mode, follow these steps to add a Layer 2 port as a member of a multicast group:

	Command	Purpose
Step 1	<code>configure terminal</code>	Enter global configuration mode.
Step 2	<code>ip igmp snooping vlan <i>vlan-id</i> static <i>ip_address</i> interface <i>interface-id</i></code>	Statically configure a Layer 2 port as a member of a multicast group: <ul style="list-style-type: none"> • <i>vlan-id</i> is the multicast group VLAN ID. The range is 1 to 1001 and 1006 to 4094. • <i>ip_address</i> is the group IP address. • <i>interface-id</i> is the member port. It can be a physical interface or a port channel (1 to 6).
Step 3	<code>end</code>	Return to privileged EXEC mode.
Step 4	<code>show ip igmp snooping groups</code>	Verify the member port and the IP address.
Step 5	<code>copy running-config startup-config</code>	(Optional) Save your entries in the configuration file.

To remove the Layer 2 port from the multicast group, use the `no ip igmp snooping vlan vlan-id static mac-address interface interface-id` global configuration command.

This example shows how to statically configure a host on a port:

```
Switch# configure terminal
Switch(config)# ip igmp snooping vlan 105 static 224.2.4.12 interface gigabitethernet0/1
Switch(config)# end
```

Enabling IGMP Immediate Leave

When you enable IGMP Immediate Leave, the switch immediately removes a port when it detects an IGMP Version 2 leave message on that port. You should only use the Immediate-Leave feature when there is a single receiver present on every port in the VLAN.



Note

Immediate Leave is supported only on IGMP Version 2 hosts.

Beginning in privileged EXEC mode, follow these steps to enable IGMP Immediate Leave:

	Command	Purpose
Step 1	<code>configure terminal</code>	Enter global configuration mode.
Step 2	<code>ip igmp snooping vlan <i>vlan-id</i> immediate-leave</code>	Enable IGMP Immediate Leave on the VLAN interface.
Step 3	<code>end</code>	Return to privileged EXEC mode.

	Command	Purpose
Step 4	show ip igmp snooping vlan <i>vlan-id</i>	Verify that Immediate Leave is enabled on the VLAN interface.
Step 5	copy running-config startup-config	(Optional) Save your entries in the configuration file.

To disable IGMP Immediate Leave on a VLAN, use the **no ip igmp snooping vlan** *vlan-id* **immediate-leave** global configuration command.

This example shows how to enable IGMP Immediate Leave on VLAN 130:

```
Switch# configure terminal
Switch(config)# ip igmp snooping vlan 130 immediate-leave
Switch(config)# end
```

Configuring the IGMP Leave Timer

Follows these guidelines when configuring the IGMP leave timer:

- You can configure the leave time globally or on a per-VLAN basis.
- Configuring the leave time on a VLAN overrides the global setting.
- The default leave time is 1000 milliseconds.
- The IGMP configurable leave time is only supported on hosts running IGMP Version 2.
- The actual leave latency in the network is usually the configured leave time. However, the leave time *might* vary around the configured time, depending on real-time CPU load conditions, network delays and the amount of traffic sent through the interface.

Beginning in privileged EXEC mode, follow these steps to enable the IGMP configurable-leave timer:

	Command	Purpose
Step 1	configure terminal	Enter global configuration mode.
Step 2	ip igmp snooping last-member-query-interval <i>time</i>	Configure the IGMP leave timer globally. The range is 100 to 5000 milliseconds. The default is 1000 seconds.
Step 3	ip igmp snooping vlan <i>vlan-id</i> last-member-query-interval <i>time</i>	(Optional) Configure the IGMP leave time on the VLAN interface. The range is 100 to 5000 milliseconds. Note Configuring the leave time on a VLAN overrides the globally configured timer.
Step 4	end	Return to privileged EXEC mode.
Step 5	show ip igmp snooping	(Optional) Display the configured IGMP leave time.
Step 6	copy running-config startup-config	(Optional) Save your entries in the configuration file.

To globally reset the IGMP leave timer to the default setting, use the **no ip igmp snooping last-member-query-interval** global configuration command.

To remove the configured IGMP leave-time setting from the specified VLAN, use the **no ip igmp snooping vlan** *vlan-id* **last-member-query-interval** global configuration command.

Configuring TCN-Related Commands

These sections describe how to control flooded multicast traffic during a TCN event:

- [Controlling the Multicast Flooding Time After a TCN Event, page 18-12](#)
- [Recovering from Flood Mode, page 18-12](#)
- [Disabling Multicast Flooding During a TCN Event, page 18-13](#)

Controlling the Multicast Flooding Time After a TCN Event

You can control the time that multicast traffic is flooded after a TCN event by using the **ip igmp snooping tcn flood query count** global configuration command. This command configures the number of general queries for which multicast data traffic is flooded after a TCN event. Some examples of TCN events are when the client changed its location and the receiver is on same port that was blocked but is now forwarding, and when a port went down without sending a leave message.

If you set the TCN flood query count to 1 by using the **ip igmp snooping tcn flood query count** command, the flooding stops after receiving 1 general query. If you set the count to 7, the flooding until 7 general queries are received. Groups are relearned based on the general queries received during the TCN event.

Beginning in privileged EXEC mode, follow these steps to configure the TCN flood query count:

	Command	Purpose
Step 1	configure terminal	Enter global configuration mode.
Step 2	ip igmp snooping tcn flood query count <i>count</i>	Specify the number of IGMP general queries for which the multicast traffic is flooded. The range is 1 to 10. By default, the flooding query count is 2.
Step 3	end	Return to privileged EXEC mode.
Step 4	show ip igmp snooping	Verify the TCN settings.
Step 5	copy running-config startup-config	(Optional) Save your entries in the configuration file.

To return to the default flooding query count, use the **no ip igmp snooping tcn flood query count** global configuration command.

Recovering from Flood Mode

When a topology change occurs, the spanning-tree root sends a special IGMP leave message (also known as global leave) with the group multicast address 0.0.0.0. However, when you enable the **ip igmp snooping tcn query solicit** global configuration command, the switch sends the global leave message whether or not it is the spanning-tree root. When the router receives this special leave, it immediately sends general queries, which expedite the process of recovering from the flood mode during the TCN event. Leaves are always sent if the switch is the spanning-tree root regardless of this configuration command. By default, query solicitation is disabled.

Beginning in privileged EXEC mode, follow these steps to enable the switch to send the global leave message whether or not it is the spanning-tree root:

	Command	Purpose
Step 1	configure terminal	Enter global configuration mode.
Step 2	ip igmp snooping tcn query solicit	Send an IGMP leave message (global leave) to speed the process of recovering from the flood mode caused during a TCN event. By default, query solicitation is disabled.
Step 3	end	Return to privileged EXEC mode.
Step 4	show ip igmp snooping	Verify the TCN settings.
Step 5	copy running-config startup-config	(Optional) Save your entries in the configuration file.

To return to the default query solicitation, use the **no ip igmp snooping tcn query solicit** global configuration command.

Disabling Multicast Flooding During a TCN Event

When the switch receives a TCN, multicast traffic is flooded to all the ports until 2 general queries are received. If the switch has many ports with attached hosts that are subscribed to different multicast groups, this flooding might exceed the capacity of the link and cause packet loss. You can use the **ip igmp snooping tcn flood** interface configuration command to control this behavior.

Beginning in privileged EXEC mode, follow these steps to disable multicast flooding on an interface:

	Command	Purpose
Step 1	configure terminal	Enter global configuration mode.
Step 2	interface <i>interface-id</i>	Specify the interface to be configured, and enter interface configuration mode.
Step 3	no ip igmp snooping tcn flood	Disable the flooding of multicast traffic during a spanning-tree TCN event. By default, multicast flooding is enabled on an interface.
Step 4	exit	Return to privileged EXEC mode.
Step 5	show ip igmp snooping	Verify the TCN settings.
Step 6	copy running-config startup-config	(Optional) Save your entries in the configuration file.

To re-enable multicast flooding on an interface, use the **ip igmp snooping tcn flood** interface configuration command.

Configuring the IGMP Snooping Querier

Follow these guidelines when configuring the IGMP snooping querier:

- Configure the VLAN in global configuration mode.
- Configure an IP address on the VLAN interface. When enabled, the IGMP snooping querier uses the IP address as the query source address.
- If there is no IP address configured on the VLAN interface, the IGMP snooping querier tries to use the configured global IP address for the IGMP querier. If there is no global IP address specified, the IGMP querier tries to use the VLAN switch virtual interface (SVI) IP address (if one exists). If there is no SVI IP address, the switch uses the first available IP address configured on the switch. The first IP address available appears in the output of the **show ip interface** privileged EXEC command. The IGMP snooping querier does not generate an IGMP general query if it cannot find an available IP address on the switch.
- The IGMP snooping querier supports IGMP Versions 1 and 2.
- When administratively enabled, the IGMP snooping querier moves to the nonquerier state if it detects the presence of a multicast router in the network.
- When it is administratively enabled, the IGMP snooping querier moves to the operationally disabled state under these conditions:
 - IGMP snooping is disabled in the VLAN.
 - PIM is enabled on the SVI of the corresponding VLAN.

Beginning in privileged EXEC mode, follow these steps to enable the IGMP snooping querier feature in a VLAN:

	Command	Purpose
Step 1	configure terminal	Enter global configuration mode.
Step 2	ip igmp snooping querier	Enable the IGMP snooping querier.
Step 3	ip igmp snooping querier address <i>ip_address</i>	(Optional) Specify an IP address for the IGMP snooping querier. If you do not specify an IP address, the querier tries to use the global IP address configured for the IGMP querier. Note The IGMP snooping querier does not generate an IGMP general query if it cannot find an IP address on the switch.
Step 4	ip igmp snooping querier query-interval <i>interval-count</i>	(Optional) Set the interval between IGMP queries. The range is 1 to 18000 seconds.
Step 5	ip igmp snooping querier tcn query [count <i>count</i> interval <i>interval</i>]	(Optional) Set the time between Topology Change Notification (TCN) queries. The count range is 1 to 10. The interval range is 1 to 255 seconds.
Step 6	ip igmp snooping querier timer expiry <i>timeout</i>	(Optional) Set the length of time until the IGMP querier expires. The range is 60 to 300 seconds.
Step 7	ip igmp snooping querier version <i>version</i>	(Optional) Select the IGMP version number that the querier feature uses. Select 1 or 2.
Step 8	end	Return to privileged EXEC mode.
Step 9	show ip igmp snooping vlan <i>vlan-id</i>	(Optional) Verify that the IGMP snooping querier is enabled on the VLAN interface. The VLAN ID range is 1 to 1001 and 1006 to 4094.
Step 10	copy running-config startup-config	(Optional) Save your entries in the configuration file.

This example shows how to set the IGMP snooping querier source address to 10.0.0.64:

```
Switch# configure terminal
Switch(config)# ip igmp snooping querier 10.0.0.64
Switch(config)# end
```

This example shows how to set the IGMP snooping querier maximum response time to 25 seconds:

```
Switch# configure terminal
Switch(config)# ip igmp snooping querier query-interval 25
Switch(config)# end
```

This example shows how to set the IGMP snooping querier timeout to 60 seconds:

```
Switch# configure terminal
Switch(config)# ip igmp snooping querier timeout expiry 60
Switch(config)# end
```

This example shows how to set the IGMP snooping querier feature to version 2:

```
Switch# configure terminal
Switch(config)# no ip igmp snooping querier version 2
Switch(config)# end
```

Disabling IGMP Report Suppression



Note

IGMP report suppression is supported only when the multicast query has IGMPv1 and IGMPv2 reports. This feature is not supported when the query includes IGMPv3 reports.

IGMP report suppression is enabled by default. When it is enabled, the switch forwards only one IGMP report per multicast router query. When report suppression is disabled, all IGMP reports are forwarded to the multicast routers.

Beginning in privileged EXEC mode, follow these steps to disable IGMP report suppression:

	Command	Purpose
Step 1	configure terminal	Enter global configuration mode.
Step 2	no ip igmp snooping report-suppression	Disable IGMP report suppression.
Step 3	end	Return to privileged EXEC mode.
Step 4	show ip igmp snooping	Verify that IGMP report suppression is disabled.
Step 5	copy running-config startup-config	(Optional) Save your entries in the configuration file.

To re-enable IGMP report suppression, use the **ip igmp snooping report-suppression** global configuration command.

Displaying IGMP Snooping Information

You can display IGMP snooping information for dynamically learned and statically configured router ports and VLAN interfaces. You can also display MAC address multicast entries for a VLAN configured for IGMP snooping.

To display IGMP snooping information, use one or more of the privileged EXEC commands in Table 18-4.

Table 18-4 Commands for Displaying IGMP Snooping Information

Command	Purpose
<code>show ip igmp snooping [vlan <i>vlan-id</i>]</code>	<p>Display the snooping configuration information for all VLANs on the switch or for a specified VLAN.</p> <p>(Optional) Enter vlan <i>vlan-id</i> to display information for a single VLAN. The VLAN ID range is 1 to 1001 and 1006 to 4094.</p>
<code>show ip igmp snooping groups [count dynamic [count] user [count]]</code>	<p>Display multicast table information for the switch or about a specific parameter:</p> <ul style="list-style-type: none"> • count—Display the total number of entries for the specified command options instead of the actual entries. • dynamic—Display entries learned through IGMP snooping. • user—Display only the user-configured multicast entries.
<code>show ip igmp snooping groups vlan <i>vlan-id</i> [<i>ip_address</i> count dynamic [count] user[count]]</code>	<p>Display multicast table information for a multicast VLAN or about a specific parameter for the VLAN:</p> <ul style="list-style-type: none"> • <i>vlan-id</i>—The VLAN ID range is 1 to 1001 and 1006 to 4094. • count—Display the total number of entries for the specified command options instead of the actual entries. • dynamic—Display entries learned through IGMP snooping. • <i>ip_address</i>—Display characteristics of the multicast group with the specified group IP address. • user—Display only the user-configured multicast entries.
<code>show ip igmp snooping mrouter [vlan <i>vlan-id</i>]</code>	<p>Display information on dynamically learned and manually configured multicast router interfaces.</p> <p>Note When you enable IGMP snooping, the switch automatically learns the interface to which a multicast router is connected. These are dynamically learned interfaces.</p> <p>(Optional) Enter vlan <i>vlan-id</i> to display information for a single VLAN.</p>
<code>show ip igmp snooping querier [vlan <i>vlan-id</i>]</code>	<p>Display information about the IP address and receiving port for the most-recently received IGMP query messages in the VLAN.</p> <p>(Optional) Enter vlan <i>vlan-id</i> to display information for a single VLAN.</p>
<code>show ip igmp snooping querier [vlan <i>vlan-id</i>] detail</code>	<p>Display information about the IP address and receiving port of the most-recently received IGMP query message in the VLAN and the configuration and operational state of the IGMP snooping querier in the VLAN.</p>

For more information about the keywords and options in these commands, see the command reference for this release.

Understanding Multicast VLAN Registration

Multicast VLAN Registration (MVR) is designed for applications using wide-scale deployment of multicast traffic across an Ethernet ring-based service-provider network (for example, the broadcast of multiple television channels over a service-provider network). MVR allows a subscriber on a port to subscribe and unsubscribe to a multicast stream on the network-wide multicast VLAN. It allows the single multicast VLAN to be shared in the network while subscribers remain in separate VLANs. MVR provides the ability to continuously send multicast streams in the multicast VLAN, but to isolate the streams from the subscriber VLANs for bandwidth and security reasons.

MVR assumes that subscriber ports subscribe and unsubscribe (join and leave) these multicast streams by sending out IGMP join and leave messages. These messages can originate from an IGMP Version-2-compatible host with an Ethernet connection. Although MVR operates on the underlying mechanism of IGMP snooping, the two features operate independently of each other. One can be enabled or disabled without affecting the behavior of the other feature. However, if IGMP snooping and MVR are both enabled, MVR reacts only to join and leave messages from multicast groups configured under MVR. Join and leave messages from all other multicast groups are managed by IGMP snooping.

The switch CPU identifies the MVR IP multicast streams and their associated IP multicast group in the switch forwarding table, intercepts the IGMP messages, and modifies the forwarding table to include or remove the subscriber as a receiver of the multicast stream, even though the receivers might be in a different VLAN from the source. This forwarding behavior selectively allows traffic to cross between different VLANs.

You can set the switch for compatible or dynamic mode of MVR operation:

- In compatible mode, multicast data received by MVR hosts is forwarded to all MVR data ports, regardless of MVR host membership on those ports. The multicast data is forwarded only to those receiver ports that MVR hosts have joined, either by IGMP reports or by MVR static configuration. IGMP reports received from MVR hosts are never forwarded from MVR data ports that were configured in the switch.
- In dynamic mode, multicast data received by MVR hosts on the switch is forwarded from only those MVR data and client ports that the MVR hosts have joined, either by IGMP reports or by MVR static configuration. Any IGMP reports received from MVR hosts are also forwarded from all the MVR data ports in the switch. This eliminates using unnecessary bandwidth on MVR data port links, which occurs when the switch runs in compatible mode.

Only Layer 2 ports take part in MVR. You must configure ports as MVR receiver ports. Only one MVR multicast VLAN per switch is supported.

Using MVR in a Multicast Television Application

In a multicast television application, a PC or a television with a set-top box can receive the multicast stream. Multiple set-top boxes or PCs can be connected to one subscriber port, which is a switch port configured as an MVR receiver port. [Figure 18-3](#) is an example configuration. DHCP assigns an IP address to the set-top box or the PC. When a subscriber selects a channel, the set-top box or PC sends an IGMP report to Switch A to join the appropriate multicast. If the IGMP report matches one of the configured IP multicast group addresses, the switch CPU modifies the hardware address table to include this receiver port and VLAN as a forwarding destination of the specified multicast stream when it is received from the multicast VLAN. Uplink ports that send and receive multicast data to and from the multicast VLAN are called MVR source ports.

Figure 18-3 Multicast VLAN Registration Example

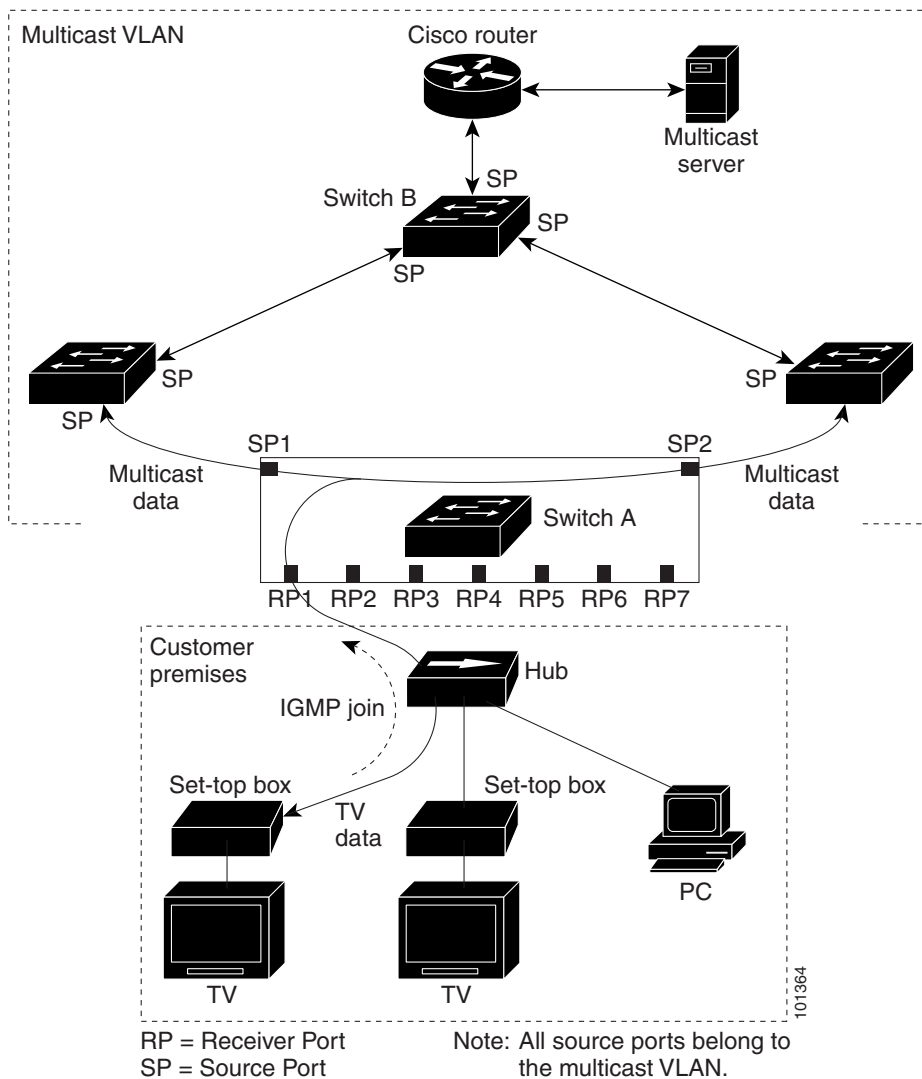

When a subscriber changes channels or turns off the television, the set-top box sends an IGMP leave message for the multicast stream. The switch CPU sends a MAC-based general query through the receiver port VLAN. If there is another set-top box in the VLAN still subscribing to this group, that set-top box must respond within the maximum response time specified in the query. If the CPU does not receive a response, it eliminates the receiver port as a forwarding destination for this group.

Without Immediate Leave, when the switch receives an IGMP leave message from a subscriber on a receiver port, it sends out an IGMP query on that port and waits for IGMP group membership reports. If no reports are received in a configured time period, the receiver port is removed from multicast group membership. With Immediate Leave, an IGMP query is not sent from the receiver port on which the IGMP leave was received. As soon as the leave message is received, the receiver port is removed from multicast group membership, which speeds up leave latency. Enable the Immediate-Leave feature only on receiver ports to which a single receiver device is connected.

MVR eliminates the need to duplicate television-channel multicast traffic for subscribers in each VLAN. Multicast traffic for all channels is only sent around the VLAN trunk once—only on the multicast VLAN. The IGMP leave and join messages are in the VLAN to which the subscriber port is assigned. These messages dynamically register for streams of multicast traffic in the multicast VLAN on the Layer 3 device, Switch B. The access layer switch, Switch A, modifies the forwarding behavior to allow the traffic to be forwarded from the multicast VLAN to the subscriber port in a different VLAN, selectively allowing traffic to cross between two VLANs.

IGMP reports are sent to the same IP multicast group address as the multicast data. The Switch A CPU must capture all IGMP join and leave messages from receiver ports and forward them to the multicast VLAN of the source (uplink) port, based on the MVR mode.

Configuring MVR

These sections contain this configuration information:

- [Default MVR Configuration, page 18-19](#)
- [MVR Configuration Guidelines and Limitations, page 18-20](#)
- [Configuring MVR Global Parameters, page 18-20](#)
- [Configuring MVR Interfaces, page 18-21](#)

Default MVR Configuration

[Table 18-5](#) shows the default MVR configuration.

Table 18-5 *Default MVR Configuration*

Feature	Default Setting
MVR	Disabled globally and per interface
Multicast addresses	None configured
Query response time	0.5 second
Multicast VLAN	VLAN 1
Mode	Compatible

Table 18-5 Default MVR Configuration (continued)

Feature	Default Setting
Interface (per port) default	Neither a receiver nor a source port
Immediate Leave	Disabled on all ports

MVR Configuration Guidelines and Limitations

Follow these guidelines when configuring MVR:

- Receiver ports can only be access ports; they cannot be trunk ports. Receiver ports on a switch can be in different VLANs, but should not belong to the multicast VLAN.
- The maximum number of multicast entries (MVR group addresses) that can be configured on a switch (that is, the maximum number of television channels that can be received) is 256.
- MVR multicast data received in the source VLAN and leaving from receiver ports has its time-to-live (TTL) decremented by 1 in the switch.
- Because MVR on the switch uses IP multicast addresses instead of MAC multicast addresses, aliased IP multicast addresses are allowed on the switch. However, if the switch is interoperating with Catalyst 3550 or Catalyst 3500 XL switches, you should not configure IP addresses that alias between themselves or with the reserved IP multicast addresses (in the range 224.0.0.xxx).
- MVR can coexist with IGMP snooping on a switch.
- MVR data received on an MVR receiver port is not forwarded to MVR source ports.
- MVR does not support IGMPv3 messages.

Configuring MVR Global Parameters

You do not need to set the optional MVR parameters if you choose to use the default settings. If you do want to change the default parameters (except for the MVR VLAN), you must first enable MVR.



Note

For complete syntax and usage information for the commands used in this section, see the command reference for this release.

Beginning in privileged EXEC mode, follow these steps to configure MVR parameters:

	Command	Purpose
Step 1	configure terminal	Enter global configuration mode.
Step 2	mvr	Enable MVR on the switch.
Step 3	mvr group ip-address [count]	Configure an IP multicast address on the switch or use the <i>count</i> parameter to configure a contiguous series of MVR group addresses (the range for <i>count</i> is 1 to 256; the default is 1). Any multicast data sent to this address is sent to all source ports on the switch and all receiver ports that have elected to receive data on that multicast address. Each multicast address would correspond to one television channel.

	Command	Purpose
Step 4	mvr querytime <i>value</i>	(Optional) Define the maximum time to wait for IGMP report memberships on a receiver port before removing the port from multicast group membership. The value is in units of tenths of a second. The range is 1 to 100, and the default is 5 tenths or one-half second.
Step 5	mvr vlan <i>vlan-id</i>	(Optional) Specify the VLAN in which multicast data is received; all source ports must belong to this VLAN. The VLAN range is 1 to 1001 and 1006 to 4094. The default is VLAN 1.
Step 6	mvr mode { dynamic compatible }	(Optional) Specify the MVR mode of operation: <ul style="list-style-type: none"> dynamic—Allows dynamic MVR membership on source ports. compatible—Is compatible with Catalyst 3500 XL and Catalyst 2900 XL switches and does not support IGMP dynamic joins on source ports. The default is compatible mode.
Step 7	end	Return to privileged EXEC mode.
Step 8	show mvr or show mvr members	Verify the configuration.
Step 9	copy running-config startup-config	(Optional) Save your entries in the configuration file.

To return the switch to its default settings, use the **no mvr** [**mode** | **group ip-address** | **querytime** | **vlan**] global configuration commands.

This example shows how to enable MVR, configure the group address, set the query time to 1 second (10 tenths), specify the MVR multicast VLAN as VLAN 22, and set the MVR mode as dynamic:

```
Switch(config)# mvr
Switch(config)# mvr group 228.1.23.4
Switch(config)# mvr querytime 10
Switch(config)# mvr vlan 22
Switch(config)# mvr mode dynamic
Switch(config)# end
```

You can use the **show mvr members** privileged EXEC command to verify the MVR multicast group addresses on the switch.

Configuring MVR Interfaces

Beginning in privileged EXEC mode, follow these steps to configure Layer 2 MVR interfaces:

	Command	Purpose
Step 1	configure terminal	Enter global configuration mode.
Step 2	mvr	Enable MVR on the switch.
Step 3	interface <i>interface-id</i>	Specify the Layer 2 port to configure, and enter interface configuration mode.

	Command	Purpose
Step 4	mvr type {source receiver}	<p>Configure an MVR port as one of these:</p> <ul style="list-style-type: none"> • source—Configure uplink ports that receive and send multicast data as source ports. Subscribers cannot be directly connected to source ports. All source ports on a switch belong to the single multicast VLAN. • receiver—Configure a port as a receiver port if it is a subscriber port and should only receive multicast data. It does not receive data unless it becomes a member of the multicast group, either statically or by using IGMP leave and join messages. Receiver ports cannot belong to the multicast VLAN. <p>The default configuration is as a non-MVR port. If you attempt to configure a non-MVR port with MVR characteristics, the operation fails.</p>
Step 5	mvr vlan <i>vlan-id</i> group [<i>ip-address</i>]	<p>(Optional) Statically configure a port to receive multicast traffic sent to the multicast VLAN and the IP multicast address. A port statically configured as a member of a group remains a member of the group until statically removed.</p> <p>Note In compatible mode, this command applies to only receiver ports. In dynamic mode, it applies to receiver ports and source ports.</p> <p>Receiver ports can also dynamically join multicast groups by using IGMP join and leave messages.</p>
Step 6	mvr immediate	<p>(Optional) Enable the Immediate-Leave feature of MVR on the port.</p> <p>Note This command applies to only receiver ports and should only be enabled on receiver ports to which a single receiver device is connected.</p>
Step 7	end	Return to privileged EXEC mode.
Step 8	show mvr show mvr interface or show mvr members	Verify the configuration.
Step 9	copy running-config startup-config	(Optional) Save your entries in the configuration file.

To return the interface to its default settings, use the **no mvr [type | immediate | vlan *vlan-id* | group]** interface configuration commands.

This example shows how to configure a port as a receiver port, statically configure the port to receive multicast traffic sent to the multicast group address, configure Immediate Leave on the port, and verify the results.

```
Switch(config)# mvr
Switch(config)# interface gigabitethernet0/2
Switch(config-if)# mvr type receiver
Switch(config-if)# mvr vlan 22 group 228.1.23.4
Switch(config-if)# mvr immediate
Switch(config)# end
Switch# show mvr interface
Port      Type      Status      Immediate Leave
----      -
Gi0/2    RECEIVER  ACTIVE/DOWN  ENABLED
```

Displaying MVR Information

You can display MVR information for the switch or for a specified interface. Beginning in privileged EXEC mode, use the commands in [Table 18-6](#) to display MVR configuration:

Table 18-6 *Commands for Displaying MVR Information*

Command	Purpose
<code>show mvr</code>	Displays MVR status and values for the switch—whether MVR is enabled or disabled, the multicast VLAN, the maximum (256) and current (0 through 256) number of multicast groups, the query response time, and the MVR mode.
<code>show mvr interface [interface-id] [members [vlan vlan-id]]</code>	<p>Displays all MVR interfaces and their MVR configurations.</p> <p>When a specific interface is entered, displays this information:</p> <ul style="list-style-type: none"> • Type—Receiver or Source • Status—One of these: <ul style="list-style-type: none"> – Active means the port is part of a VLAN. – Up/Down means that the port is forwarding or nonforwarding. – Inactive means that the port is not part of any VLAN. • Immediate Leave—Enabled or Disabled <p>If the members keyword is entered, displays all multicast group members on this port or, if a VLAN identification is entered, all multicast group members on the VLAN. The VLAN ID range is 1 to 1001 and 1006 to 4094.</p>
<code>show mvr members [ip-address]</code>	Displays all receiver and source ports that are members of any IP multicast group or the specified IP multicast group IP address.

Configuring IGMP Filtering and Throttling

In some environments, for example, metropolitan or multiple-dwelling unit (MDU) installations, you might want to control the set of multicast groups to which a user on a switch port can belong. You can control the distribution of multicast services, such as IP/TV, based on some type of subscription or service plan. You might also want to limit the number of multicast groups to which a user on a switch port can belong.

With the IGMP filtering feature, you can filter multicast joins on a per-port basis by configuring IP multicast profiles and associating them with individual switch ports. An IGMP profile can contain one or more multicast groups and specifies whether access to the group is permitted or denied. If an IGMP profile denying access to a multicast group is applied to a switch port, the IGMP join report requesting the stream of IP multicast traffic is dropped, and the port is not allowed to receive IP multicast traffic from that group. If the filtering action permits access to the multicast group, the IGMP report from the port is forwarded for normal processing. You can also set the maximum number of IGMP groups that a Layer 2 interface can join.

IGMP filtering controls only group-specific query and membership reports, including join and leave reports. It does not control general IGMP queries. IGMP filtering has no relationship with the function that directs the forwarding of IP multicast traffic. The filtering feature operates in the same manner whether CGMP or MVR is used to forward the multicast traffic.

IGMP filtering is applicable only to the dynamic learning of IP multicast group addresses, not static configuration.

With the IGMP throttling feature, you can set the maximum number of IGMP groups that a Layer 2 interface can join. If the maximum number of IGMP groups is set, the IGMP snooping forwarding table contains the maximum number of entries, and the interface receives an IGMP join report, you can configure an interface to drop the IGMP report or to replace the randomly selected multicast entry with the received IGMP report.

**Note**

IGMPv3 join and leave messages are not supported on switches running IGMP filtering.

These sections contain this configuration information:

- [Default IGMP Filtering and Throttling Configuration, page 18-24](#)
- [Configuring IGMP Profiles, page 18-24](#) (optional)
- [Applying IGMP Profiles, page 18-25](#) (optional)
- [Setting the Maximum Number of IGMP Groups, page 18-26](#) (optional)
- [Configuring the IGMP Throttling Action, page 18-27](#) (optional)

Default IGMP Filtering and Throttling Configuration

[Table 18-7](#) shows the default IGMP filtering configuration.

Table 18-7 *Default IGMP Filtering Configuration*

Feature	Default Setting
IGMP filters	None applied
IGMP maximum number of IGMP groups	No maximum set
IGMP profiles	None defined
IGMP profile action	Deny the range addresses

When the maximum number of groups is in forwarding table, the default IGMP throttling action is to deny the IGMP report. For configuration guidelines, see the [“Configuring the IGMP Throttling Action” section on page 18-27](#).

Configuring IGMP Profiles

To configure an IGMP profile, use the **ip igmp profile** global configuration command with a profile number to create an IGMP profile and to enter IGMP profile configuration mode. From this mode, you can specify the parameters of the IGMP profile to be used for filtering IGMP join requests from a port. When you are in IGMP profile configuration mode, you can create the profile by using these commands:

- **deny**: Specifies that matching addresses are denied; this is the default.
- **exit**: Exits from igmp-profile configuration mode.
- **no**: Negates a command or returns to its defaults.

- **permit**: Specifies that matching addresses are permitted.
- **range**: Specifies a range of IP addresses for the profile. You can enter a single IP address or a range with a start and an end address.

The default is for the switch to have no IGMP profiles configured. When a profile is configured, if neither the **permit** nor **deny** keyword is included, the default is to deny access to the range of IP addresses.

Beginning in privileged EXEC mode, follow these steps to create an IGMP profile:

	Command	Purpose
Step 1	configure terminal	Enter global configuration mode.
Step 2	ip igmp profile <i>profile number</i>	Assign a number to the profile you are configuring, and enter IGMP profile configuration mode. The profile number range is 1 to 4294967295.
Step 3	permit deny	(Optional) Set the action to permit or deny access to the IP multicast address. If no action is configured, the default for the profile is to deny access.
Step 4	range <i>ip multicast address</i>	Enter the IP multicast address or range of IP multicast addresses to which access is being controlled. If entering a range, enter the low IP multicast address, a space, and the high IP multicast address. You can use the range command multiple times to enter multiple addresses or ranges of addresses.
Step 5	end	Return to privileged EXEC mode.
Step 6	show ip igmp profile <i>profile number</i>	Verify the profile configuration.
Step 7	copy running-config startup-config	(Optional) Save your entries in the configuration file.

To delete a profile, use the **no ip igmp profile** *profile number* global configuration command.

To delete an IP multicast address or range of IP multicast addresses, use the **no range** *ip multicast address* IGMP profile configuration command.

This example shows how to create IGMP profile 4 allowing access to the single IP multicast address and how to verify the configuration. If the action was to deny (the default), it would not appear in the **show ip igmp profile** output display.

```
Switch(config)# ip igmp profile 4
Switch(config-igmp-profile)# permit
Switch(config-igmp-profile)# range 229.9.9.0
Switch(config-igmp-profile)# end
Switch# show ip igmp profile 4
IGMP Profile 4
    permit
    range 229.9.9.0 229.9.9.0
```

Applying IGMP Profiles

To control access as defined in an IGMP profile, use the **ip igmp filter** interface configuration command to apply the profile to the appropriate interfaces. You can apply IGMP profiles only to Layer 2 access ports. You cannot apply profiles to ports that belong to an EtherChannel port group. You can apply a profile to multiple interfaces, but each interface can have only one profile applied to it.

Beginning in privileged EXEC mode, follow these steps to apply an IGMP profile to a switch port:

	Command	Purpose
Step 1	configure terminal	Enter global configuration mode.
Step 2	interface <i>interface-id</i>	Specify the physical interface, and enter interface configuration mode. The interface must be a Layer 2 port that does not belong to an EtherChannel port group.
Step 3	ip igmp filter <i>profile number</i>	Apply the specified IGMP profile to the interface. The range is 1 to 4294967295.
Step 4	end	Return to privileged EXEC mode.
Step 5	show running-config interface <i>interface-id</i>	Verify the configuration.
Step 6	copy running-config startup-config	(Optional) Save your entries in the configuration file.

To remove a profile from an interface, use the **no ip igmp filter** *profile number* interface configuration command.

This example shows how to apply IGMP profile 4 to a port:

```
Switch(config)# interface gigabitethernet0/2
Switch(config-if)# ip igmp filter 4
Switch(config-if)# end
```

Setting the Maximum Number of IGMP Groups

You can set the maximum number of IGMP groups that a Layer 2 interface can join by using the **ip igmp max-groups** interface configuration command. Use the **no** form of this command to set the maximum back to the default, which is no limit.

You can use this command on a logical EtherChannel interface but cannot use it on ports that belong to an EtherChannel port group.

Beginning in privileged EXEC mode, follow these steps to set the maximum number of IGMP groups in the forwarding table:

	Command	Purpose
Step 1	configure terminal	Enter global configuration mode.
Step 2	interface <i>interface-id</i>	Specify the interface to be configured, and enter interface configuration mode. The interface can be a Layer 2 port that does not belong to an EtherChannel group or a EtherChannel interface.
Step 3	ip igmp max-groups <i>number</i>	Set the maximum number of IGMP groups that the interface can join. The range is 0 to 4294967294. The default is to have no maximum set.
Step 4	end	Return to privileged EXEC mode.
Step 5	show running-config interface <i>interface-id</i>	Verify the configuration.
Step 6	copy running-config startup-config	(Optional) Save your entries in the configuration file.

To remove the maximum group limitation and return to the default of no maximum, use the **no ip igmp max-groups** interface configuration command.

This example shows how to limit to 25 the number of IGMP groups that a port can join.

```
Switch(config)# interface gigabitethernet0/2
Switch(config-if)# ip igmp max-groups 25
Switch(config-if)# end
```

Configuring the IGMP Throttling Action

After you set the maximum number of IGMP groups that a Layer 2 interface can join, you can configure an interface to replace the existing group with the new group for which the IGMP report was received by using the **ip igmp max-groups action replace** interface configuration command. Use the **no** form of this command to return to the default, which is to drop the IGMP join report.

Follow these guidelines when configuring the IGMP throttling action:

- You can use this command on a logical EtherChannel interface but cannot use it on ports that belong to an EtherChannel port group.
- When the maximum group limitation is set to the default (no maximum), entering the **ip igmp max-groups action {deny | replace}** command has no effect.
- If you configure the throttling action and set the maximum group limitation after an interface has added multicast entries to the forwarding table, the forwarding-table entries are either aged out or removed, depending on the throttling action.
 - If you configure the throttling action as **deny**, the entries that were previously in the forwarding table are not removed but are aged out. After these entries are aged out and the maximum number of entries is in the forwarding table, the switch drops the next IGMP report received on the interface.
 - If you configure the throttling action as **replace**, the entries that were previously in the forwarding table are removed. When the maximum number of entries is in the forwarding table, the switch replaces a randomly selected entry with the received IGMP report.

To prevent the switch from removing the forwarding-table entries, you can configure the IGMP throttling action before an interface adds entries to the forwarding table.

Beginning in privileged EXEC mode, follow these steps to configure the throttling action when the maximum number of entries is in the forwarding table:

	Command	Purpose
Step 1	configure terminal	Enter global configuration mode.
Step 2	interface <i>interface-id</i>	Specify the physical interface to be configured, and enter interface configuration mode. The interface can be a Layer 2 port that does not belong to an EtherChannel group or an EtherChannel interface. The interface cannot be a trunk port.
Step 3	ip igmp max-groups action {deny replace}	When an interface receives an IGMP report and the maximum number of entries is in the forwarding table, specify the action that the interface takes: <ul style="list-style-type: none"> • deny—Drop the report. • replace—Replace the existing group with the new group for which the IGMP report was received.

	Command	Purpose
Step 4	end	Return to privileged EXEC mode.
Step 5	show running-config interface <i>interface-id</i>	Verify the configuration.
Step 6	copy running-config startup-config	(Optional) Save your entries in the configuration file.

To return to the default action of dropping the report, use the **no ip igmp max-groups action** interface configuration command.

Displaying IGMP Filtering and Throttling Configuration

You can display IGMP profile characteristics, and you can display the IGMP profile and maximum group configuration for all interfaces on the switch or for a specified interface. You can also display the IGMP throttling configuration for all interfaces on the switch or for a specified interface.

Use the privileged EXEC commands in [Table 18-8](#) to display IGMP filtering and throttling configuration:

Table 18-8 **Commands for Displaying IGMP Filtering and Throttling Configuration**

Command	Purpose
show ip igmp profile [<i>profile number</i>]	Displays the specified IGMP profile or all the IGMP profiles defined on the switch.
show running-config [interface <i>interface-id</i>]	Displays the configuration of the specified interface or the configuration of all interfaces on the switch, including (if configured) the maximum number of IGMP groups to which an interface can belong and the IGMP profile applied to the interface.



CHAPTER 19

Configuring Port-Based Traffic Control

This chapter describes how to configure the port-based traffic control features on the Catalyst 2960 switch.



Note

For complete syntax and usage information for the commands used in this chapter, see the command reference for this release.

This chapter consists of these sections:

- [Configuring Storm Control, page 19-1](#)
- [Configuring Protected Ports, page 19-5](#)
- [Configuring Port Blocking, page 19-7](#)
- [Configuring Port Security, page 19-8](#)
- [Displaying Port-Based Traffic Control Settings, page 19-17](#)

Configuring Storm Control

These sections contain this conceptual and configuration information:

- [Understanding Storm Control, page 19-1](#)
- [Default Storm Control Configuration, page 19-3](#)
- [Configuring Storm Control and Threshold Levels, page 19-3](#)

Understanding Storm Control

Storm control prevents traffic on a LAN from being disrupted by a broadcast, multicast, or unicast storm on one of the physical interfaces. A LAN storm occurs when packets flood the LAN, creating excessive traffic and degrading network performance. Errors in the protocol-stack implementation, mistakes in network configurations, or users issuing a denial-of-service attack can cause a storm.

Storm control (or traffic suppression) monitors packets passing from an interface to the switching bus and determines if the packet is unicast, multicast, or broadcast. The switch counts the number of packets of a specified type received within the 1-second time interval and compares the measurement with a predefined suppression-level threshold.

Storm control uses one of these methods to measure traffic activity:

- Bandwidth as a percentage of the total available bandwidth of the port that can be used by the broadcast, multicast, or unicast traffic
- Traffic rate in packets per second at which broadcast, multicast, or unicast packets are received
- Traffic rate in bits per second at which broadcast, multicast, or unicast packets are received

With each method, the port blocks traffic when the rising threshold is reached. The port remains blocked until the traffic rate drops below the falling threshold (if one is specified) and then resumes normal forwarding. If the falling suppression level is not specified, the switch blocks all traffic until the traffic rate drops below the rising suppression level. In general, the higher the level, the less effective the protection against broadcast storms.



Note

When the storm control threshold for multicast traffic is reached, all multicast traffic except control traffic, such as bridge protocol data unit (BDPU) and Cisco Discovery Protocol (CDP) frames, are blocked.

The graph in [Figure 19-1](#) shows broadcast traffic patterns on an interface over a given period of time. The example can also be applied to multicast and unicast traffic. In this example, the broadcast traffic being forwarded exceeded the configured threshold between time intervals T1 and T2 and between T4 and T5. When the amount of specified traffic exceeds the threshold, all traffic of that kind is dropped for the next time period. Therefore, broadcast traffic is blocked during the intervals following T2 and T5. At the next time interval (for example, T3), if broadcast traffic does not exceed the threshold, it is again forwarded.

Figure 19-1 Broadcast Storm Control Example

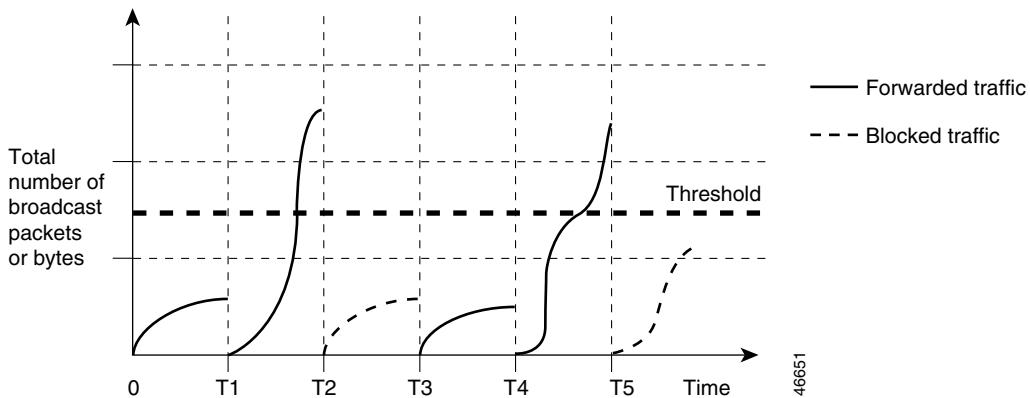

The combination of the storm-control suppression level and the 1-second time interval controls the way the storm control algorithm works. A higher threshold allows more packets to pass through. A threshold value of 100 percent means that no limit is placed on the traffic. A value of 0.0 means that all broadcast, multicast, or unicast traffic on that port is blocked.

**Note**

Because packets do not arrive at uniform intervals, the 1-second time interval during which traffic activity is measured can affect the behavior of storm control.

You use the **storm-control** interface configuration commands to set the threshold value for each traffic type.

Default Storm Control Configuration

By default, unicast, broadcast, and multicast storm control are disabled on the switch interfaces; that is, the suppression level is 100 percent.

Configuring Storm Control and Threshold Levels

You configure storm control on a port and enter the threshold level that you want to be used for a particular type of traffic.

However, because of hardware limitations and the way in which packets of different sizes are counted, threshold percentages are approximations. Depending on the sizes of the packets making up the incoming traffic, the actual enforced threshold might differ from the configured level by several percentage points.

**Note**

Storm control is supported on physical interfaces. You can also configure storm control on an EtherChannel. When storm control is configured on an EtherChannel, the storm control settings propagate to the EtherChannel physical interfaces.

Beginning in privileged EXEC mode, follow these steps to storm control and threshold levels:

	Command	Purpose
Step 1	configure terminal	Enter global configuration mode.
Step 2	interface <i>interface-id</i>	Specify the interface to be configured, and enter interface configuration mode.

Command	Purpose
Step 3 storm-control { broadcast multicast unicast } level { <i>level</i> [<i>level-low</i>] bps <i>bps</i> [<i>bps-low</i>] pps <i>pps</i> [<i>pps-low</i>]}	<p>Configure broadcast, multicast, or unicast storm control. By default, storm control is disabled.</p> <p>The keywords have these meanings:</p> <ul style="list-style-type: none"> For <i>level</i>, specify the rising threshold level for broadcast, multicast, or unicast traffic as a percentage (up to two decimal places) of the bandwidth. The port blocks traffic when the rising threshold is reached. The range is 0.00 to 100.00. (Optional) For <i>level-low</i>, specify the falling threshold level as a percentage (up to two decimal places) of the bandwidth. This value must be less than or equal to the rising suppression value. The port forwards traffic when traffic drops below this level. If you do not configure a falling suppression level, it is set to the rising suppression level. The range is 0.00 to 100.00. <p>If you set the threshold to the maximum value (100 percent), no limit is placed on the traffic. If you set the threshold to 0.0, all broadcast, multicast, and unicast traffic on that port is blocked.</p> <ul style="list-style-type: none"> For bps <i>bps</i>, specify the rising threshold level for broadcast, multicast, or unicast traffic in bits per second (up to one decimal place). The port blocks traffic when the rising threshold is reached. The range is 0.0 to 10000000000.0. (Optional) For <i>bps-low</i>, specify the falling threshold level in bits per second (up to one decimal place). It can be less than or equal to the rising threshold level. The port forwards traffic when traffic drops below this level. The range is 0.0 to 10000000000.0. For pps <i>pps</i>, specify the rising threshold level for broadcast, multicast, or unicast traffic in packets per second (up to one decimal place). The port blocks traffic when the rising threshold is reached. The range is 0.0 to 10000000000.0. (Optional) For <i>pps-low</i>, specify the falling threshold level in packets per second (up to one decimal place). It can be less than or equal to the rising threshold level. The port forwards traffic when traffic drops below this level. The range is 0.0 to 10000000000.0. <p>For BPS and PPS settings, you can use metric suffixes such as k, m, and g for large number thresholds.</p>
Step 4 storm-control action { shutdown trap }	<p>Specify the action to be taken when a storm is detected. The default is to filter out the traffic and not to send traps.</p> <ul style="list-style-type: none"> Select the shutdown keyword to error-disable the port during a storm. Select the trap keyword to generate an SNMP trap when a storm is detected.
Step 5 end	<p>Return to privileged EXEC mode.</p>

	Command	Purpose
Step 6	<code>show storm-control [interface-id] [broadcast multicast unicast]</code>	Verify the storm control suppression levels set on the interface for the specified traffic type. If you do not enter a traffic type, broadcast storm control settings are displayed.
Step 7	<code>copy running-config startup-config</code>	(Optional) Save your entries in the configuration file.

To disable storm control, use the `no storm-control { broadcast | multicast | unicast } level` interface configuration command.

This example shows how to enable unicast storm control on a port with an 87-percent rising suppression level and a 65-percent falling suppression level:

```
Switch# configure terminal
Switch(config)# interface gigabitethernet0/1
Switch(config-if)# storm-control unicast level 87 65
```

This example shows how to enable broadcast address storm control on a port to a level of 20 percent. When the broadcast traffic exceeds the configured level of 20 percent of the total available bandwidth of the port within the traffic-storm-control interval, the switch drops all broadcast traffic until the end of the traffic-storm-control interval:

```
Switch# configure terminal
Switch(config)# interface gigabitethernet0/1
Switch(config-if)# storm-control broadcast level 20
```

Configuring Protected Ports

Some applications require that no traffic be forwarded at Layer 2 between ports on the same switch so that one neighbor does not see the traffic generated by another neighbor. In such an environment, the use of protected ports ensures that there is no exchange of unicast, broadcast, or multicast traffic between these ports on the switch.

Protected ports have these features:

- A protected port does not forward any traffic (unicast, multicast, or broadcast) to any other port that is also a protected port. Data traffic cannot be forwarded between protected ports at Layer 2; only control traffic, such as PIM packets, is forwarded because these packets are processed by the CPU and forwarded in software. All data traffic passing between protected ports must be forwarded through a Layer 3 device.
- Forwarding behavior between a protected port and a nonprotected port proceeds as usual.

These sections contain this configuration information:

- [Default Protected Port Configuration, page 19-6](#)
- [Protected Port Configuration Guidelines, page 19-6](#)
- [Configuring a Protected Port, page 19-6](#)

Default Protected Port Configuration

The default is to have no protected ports defined.

Protected Port Configuration Guidelines

You can configure protected ports on a physical interface (for example, Gigabit Ethernet port 1) or an EtherChannel group (for example, port-channel 5). When you enable protected ports for a port channel, it is enabled for all ports in the port-channel group.

Configuring a Protected Port

Beginning in privileged EXEC mode, follow these steps to define a port as a protected port:

	Command	Purpose
Step 1	configure terminal	Enter global configuration mode.
Step 2	interface <i>interface-id</i>	Specify the interface to be configured, and enter interface configuration mode.
Step 3	switchport protected	Configure the interface to be a protected port.
Step 4	end	Return to privileged EXEC mode.
Step 5	show interfaces <i>interface-id</i> switchport	Verify your entries.
Step 6	copy running-config startup-config	(Optional) Save your entries in the configuration file.

To disable protected port, use the **no switchport protected** interface configuration command.

This example shows how to configure a port as a protected port:

```
Switch# configure terminal
Switch(config)# interface gigabitethernet0/1
Switch(config-if)# switchport protected
Switch(config-if)# end
```

Configuring Port Blocking

By default, the switch floods packets with unknown destination MAC addresses out of all ports. If unknown unicast and multicast traffic is forwarded to a protected port, there could be security issues. To prevent unknown unicast or multicast traffic from being forwarded from one port to another, you can block a port (protected or nonprotected) from flooding unknown unicast or multicast packets to other ports.

These sections contain this configuration information:

- [Default Port Blocking Configuration, page 19-7](#)
- [Blocking Flooded Traffic on an Interface, page 19-7](#)

Default Port Blocking Configuration

The default is to not block flooding of unknown multicast and unicast traffic out of a port, but to flood these packets to all ports.

Blocking Flooded Traffic on an Interface



Note

The interface can be a physical interface or an EtherChannel group. When you block multicast or unicast traffic for a port channel, it is blocked on all ports in the port-channel group.

Beginning in privileged EXEC mode, follow these steps to disable the flooding of multicast and unicast packets out of an interface:

	Command	Purpose
Step 1	configure terminal	Enter global configuration mode.
Step 2	interface <i>interface-id</i>	Specify the interface to be configured, and enter interface configuration mode.
Step 3	switchport block multicast	Block unknown multicast forwarding out of the port.
Step 4	switchport block unicast	Block unknown unicast forwarding out of the port.
Step 5	end	Return to privileged EXEC mode.
Step 6	show interfaces <i>interface-id</i> switchport	Verify your entries.
Step 7	copy running-config startup-config	(Optional) Save your entries in the configuration file.

To return the interface to the default condition where no traffic is blocked and normal forwarding occurs on the port, use the **no switchport block {multicast | unicast}** interface configuration commands.

This example shows how to block unicast and multicast flooding on a port:

```
Switch# configure terminal
Switch(config)# interface gigabitethernet0/1
Switch(config-if)# switchport block multicast
Switch(config-if)# switchport block unicast
Switch(config-if)# end
```

Configuring Port Security

You can use the port security feature to restrict input to an interface by limiting and identifying MAC addresses of the stations allowed to access the port. When you assign secure MAC addresses to a secure port, the port does not forward packets with source addresses outside the group of defined addresses. If you limit the number of secure MAC addresses to one and assign a single secure MAC address, the workstation attached to that port is assured the full bandwidth of the port.

If a port is configured as a secure port and the maximum number of secure MAC addresses is reached, when the MAC address of a station attempting to access the port is different from any of the identified secure MAC addresses, a security violation occurs. Also, if a station with a secure MAC address configured or learned on one secure port attempts to access another secure port, a violation is flagged.

These sections contain this conceptual and configuration information:

- [Understanding Port Security, page 19-8](#)
- [Default Port Security Configuration, page 19-10](#)
- [Port Security Configuration Guidelines, page 19-10](#)
- [Enabling and Configuring Port Security, page 19-11](#)
- [Enabling and Configuring Port Security Aging, page 19-16](#)

Understanding Port Security

These sections contain this conceptual information:

- [Secure MAC Addresses, page 19-8](#)
- [Security Violations, page 19-9](#)

Secure MAC Addresses

You configure the maximum number of secure addresses allowed on a port by using the **switchport port-security maximum** *value* interface configuration command.

**Note**

If you try to set the maximum value to a number less than the number of secure addresses already configured on an interface, the command is rejected.

The switch supports these types of secure MAC addresses:

- **Static secure MAC addresses**—These are manually configured by using the **switchport port-security mac-address** *mac-address* interface configuration command, stored in the address table, and added to the switch running configuration.
- **Dynamic secure MAC addresses**—These are dynamically configured, stored only in the address table, and removed when the switch restarts.
- **Sticky secure MAC addresses**—These can be dynamically learned or manually configured, stored in the address table, and added to the running configuration. If these addresses are saved in the configuration file, when the switch restarts, the interface does not need to dynamically reconfigure them.

You can configure an interface to convert the dynamic MAC addresses to sticky secure MAC addresses and to add them to the running configuration by enabling *sticky learning*. To enable sticky learning, enter the **switchport port-security mac-address sticky** interface configuration command. When you enter this command, the interface converts all the dynamic secure MAC addresses, including those that were dynamically learned before sticky learning was enabled, to sticky secure MAC addresses. All sticky secure MAC addresses are added to the running configuration.

The sticky secure MAC addresses do not automatically become part of the configuration file, which is the startup configuration used each time the switch restarts. If you save the sticky secure MAC addresses in the configuration file, when the switch restarts, the interface does not need to relearn these addresses. If you do not save the sticky secure addresses, they are lost.

If sticky learning is disabled, the sticky secure MAC addresses are converted to dynamic secure addresses and are removed from the running configuration.

The maximum number of secure MAC addresses that you can configure on a switch is set by the maximum number of available MAC addresses allowed in the system. This number is the total of available MAC addresses, including those used for other Layer 2 functions and any other secure MAC addresses configured on interfaces.

Security Violations

It is a security violation when one of these situations occurs:

- The maximum number of secure MAC addresses have been added to the address table, and a station whose MAC address is not in the address table attempts to access the interface.
- An address learned or configured on one secure interface is seen on another secure interface in the same VLAN.

You can configure the interface for one of violation modes, based on the action to be taken if a violation occurs:

- **protect**—When the number of secure MAC addresses reaches the maximum limit allowed on the port, packets with unknown source addresses are dropped until you remove a sufficient number of secure MAC addresses to drop below the maximum value or increase the number of maximum allowable addresses. You are not notified that a security violation has occurred.



Note We do not recommend configuring the protect violation mode on a trunk port. The protect mode disables learning when any VLAN reaches its maximum limit, even if the port has not reached its maximum limit.

- **restrict**—When the number of secure MAC addresses reaches the maximum limit allowed on the port, packets with unknown source addresses are dropped until you remove a sufficient number of secure MAC addresses to drop below the maximum value or increase the number of maximum allowable addresses. In this mode, you are notified that a security violation has occurred. An SNMP trap is sent, a syslog message is logged, and the violation counter increments.
- **shutdown**—A port security violation causes the interface to become error-disabled and to shut down immediately, and the port LED turns off. An SNMP trap is sent, a syslog message is logged, and the violation counter increments. When a secure port is in the error-disabled state, you can bring it out of this state by entering the **errdisable recovery cause psecure-violation** global configuration command, or you can manually re-enable it by entering the **shutdown** and **no shut down** interface configuration commands. This is the default mode.
- **shutdown vlan**—Use to set the security violation mode per-VLAN. In this mode, the VLAN is error disabled instead of the entire port when a violation occurs

Table 19-1 shows the violation mode and the actions taken when you configure an interface for port security.

Table 19-1 Security Violation Mode Actions

Violation Mode	Traffic is forwarded ¹	Sends SNMP trap	Sends syslog message	Displays error message ²	Violation counter increments	Shuts down port
protect	No	No	No	No	No	No
restrict	No	Yes	Yes	No	Yes	No
shutdown	No	Yes	Yes	No	Yes	Yes
shutdown vlan	No	Yes	Yes	No	Yes	No ³

1. Packets with unknown source addresses are dropped until you remove a sufficient number of secure MAC addresses.
2. The switch returns an error message if you manually configure an address that would cause a security violation.
3. Shuts down only the VLAN on which the violation occurred.

Default Port Security Configuration

Table 19-2 shows the default port security configuration for an interface.

Table 19-2 Default Port Security Configuration

Feature	Default Setting
Port security	Disabled on a port.
Sticky address learning	Disabled.
Maximum number of secure MAC addresses per port	1
Violation mode	Shutdown. The port shuts down when the maximum number of secure MAC addresses is exceeded.
Port security aging	Disabled. Aging time is 0. Static aging is disabled. Type is absolute.

Port Security Configuration Guidelines

Follow these guidelines when configuring port security:

- Port security can only be configured on static access ports or trunk ports. A secure port cannot be a dynamic access port.
- A secure port cannot be a destination port for Switched Port Analyzer (SPAN).
- A secure port cannot belong to a Fast EtherChannel or a Gigabit EtherChannel port group.



Note

Voice VLAN is only supported on access ports and not on trunk ports, even though the configuration is allowed.

- When you enable port security on an interface that is also configured with a voice VLAN, set the maximum allowed secure addresses on the port to two. When the port is connected to a Cisco IP phone, the IP phone requires one MAC address. The Cisco IP phone address is learned on the voice VLAN, but is not learned on the access VLAN. If you connect a single PC to the Cisco IP phone, no additional MAC addresses are required. If you connect more than one PC to the Cisco IP phone, you must configure enough secure addresses to allow one for each PC and one for the phone.
- When you enter a maximum secure address value for an interface, and the new value is greater than the previous value, the new value overwrites the previously configured value. If the new value is less than the previous value and the number of configured secure addresses on the interface exceeds the new value, the command is rejected.
- The switch does not support port security aging of sticky secure MAC addresses.

Table 19-3 summarizes port security compatibility with other port-based features.

Table 19-3 Port Security Compatibility with Other Switch Features

Type of Port or Feature on Port	Compatible with Port Security
DTP ¹ port ²	No
Trunk port	Yes
Dynamic-access port ³	No
SPAN source port	Yes
SPAN destination port	No
EtherChannel	No
Protected port	Yes
IEEE 802.1x port	Yes
Voice VLAN port ⁴	Yes
Flex Links	Yes

1. DTP = Dynamic Trunking Protocol

2. A port configured with the **switchport mode dynamic** interface configuration command.

3. A VLAN Query Protocol (VQP) port configured with the **switchport access vlan dynamic** interface configuration command.

4. You must set the maximum allowed secure addresses on the port to two plus the maximum number of secure addresses allowed on the access VLAN.

Enabling and Configuring Port Security

Beginning in privileged EXEC mode, follow these steps to restrict input to an interface by limiting and identifying MAC addresses of the stations allowed to access the port:

	Command	Purpose
Step 1	configure terminal	Enter global configuration mode.
Step 2	interface <i>interface-id</i>	Specify the interface to be configured, and enter interface configuration mode.
Step 3	switchport mode {access trunk }	Set the interface switchport mode as access or trunk; an interface in the default mode (dynamic auto) cannot be configured as a secure port.

	Command	Purpose
Step 4	<code>switchport voice vlan <i>vlan-id</i></code>	Enable voice VLAN on a port. <i>vlan-id</i> —Specify the VLAN to be used for voice traffic.
Step 5	<code>switchport port-security</code>	Enable port security on the interface.
Step 6	<code>switchport port-security [maximum <i>value</i> [vlan {<i>vlan-list</i> {access voice}}]]</code>	<p>(Optional) Set the maximum number of secure MAC addresses for the interface. The maximum number of secure MAC addresses that you can configure on a switch is set by the maximum number of available MAC addresses allowed in the system. This number is the total of available MAC addresses, including those used for other Layer 2 functions and any other secure MAC addresses configured on interfaces.</p> <p>(Optional) vlan—set a per-VLAN maximum value</p> <p>Enter one of these options after you enter the vlan keyword:</p> <ul style="list-style-type: none"> <i>vlan-list</i>—On a trunk port, you can set a per-VLAN maximum value on a range of VLANs separated by a hyphen or a series of VLANs separated by commas. For nonspecified VLANs, the per-VLAN maximum value is used. access—On an access port, specify the VLAN as an access VLAN. voice—On an access port, specify the VLAN as a voice VLAN. <p>Note The voice keyword is available only if a voice VLAN is configured on a port and if that port is not the access VLAN. If an interface is configured for voice VLAN, configure a maximum of two secure MAC addresses.</p>

Command	Purpose
Step 7 switchport port-security [violation {protect restrict shutdown shutdown vlan}]	<p>(Optional) Set the violation mode, the action to be taken when a security violation is detected, as one of these:</p> <ul style="list-style-type: none"> • protect—When the number of port secure MAC addresses reaches the maximum limit allowed on the port, packets with unknown source addresses are dropped until you remove a sufficient number of secure MAC addresses to drop below the maximum value or increase the number of maximum allowable addresses. You are not notified that a security violation has occurred. <p>Note We do not recommend configuring the protect mode on a trunk port. The protect mode disables learning when any VLAN reaches its maximum limit, even if the port has not reached its maximum limit.</p> <ul style="list-style-type: none"> • restrict—When the number of secure MAC addresses reaches the limit allowed on the port, packets with unknown source addresses are dropped until you remove a sufficient number of secure MAC addresses or increase the number of maximum allowable addresses. An SNMP trap is sent, a syslog message is logged, and the violation counter increments. • shutdown—The interface is error disabled when a violation occurs, and the port LED turns off. An SNMP trap is sent, a syslog message is logged, and the violation counter increments. • shutdown vlan—Use to set the security violation mode per VLAN. In this mode, the VLAN is error disabled instead of the entire port when a violation occurs. <p>Note When a secure port is in the error-disabled state, you can bring it out of this state by entering the errdisable recovery cause psecure-violation global configuration command. You can manually re-enable it by entering the shutdown and no shutdown interface configuration commands or by using the clear errdisable interface vlan privileged EXEC command.</p>

	Command	Purpose
Step 8	switchport port-security [mac-address <i>mac-address</i> [vlan { <i>vlan-id</i> { access voice }]]	<p>(Optional) Enter a secure MAC address for the interface. You can use this command to enter the maximum number of secure MAC addresses. If you configure fewer secure MAC addresses than the maximum, the remaining MAC addresses are dynamically learned.</p> <p>Note If you enable sticky learning after you enter this command, the secure addresses that were dynamically learned are converted to sticky secure MAC addresses and are added to the running configuration.</p> <p>(Optional) vlan—set a per-VLAN maximum value.</p> <p>Enter one of these options after you enter the vlan keyword:</p> <ul style="list-style-type: none"> • <i>vlan-id</i>—On a trunk port, you can specify the VLAN ID and the MAC address. If you do not specify a VLAN ID, the native VLAN is used. • access—On an access port, specify the VLAN as an access VLAN. • voice—On an access port, specify the VLAN as a voice VLAN. <p>Note The voice keyword is available only if a voice VLAN is configured on a port and if that port is not the access VLAN. If an interface is configured for voice VLAN, configure a maximum of two secure MAC addresses.</p>
Step 9	switchport port-security mac-address sticky	(Optional) Enable sticky learning on the interface.
Step 10	switchport port-security mac-address sticky [<i>mac-address</i> vlan { <i>vlan-id</i> { access voice }]]	<p>(Optional) Enter a sticky secure MAC address, repeating the command as many times as necessary. If you configure fewer secure MAC addresses than the maximum, the remaining MAC addresses are dynamically learned, are converted to sticky secure MAC addresses, and are added to the running configuration.</p> <p>Note If you do not enable sticky learning before this command is entered, an error message appears, and you cannot enter a sticky secure MAC address.</p> <p>(Optional) vlan—set a per-VLAN maximum value.</p> <p>Enter one of these options after you enter the vlan keyword:</p> <ul style="list-style-type: none"> • <i>vlan-id</i>—On a trunk port, you can specify the VLAN ID and the MAC address. If you do not specify a VLAN ID, the native VLAN is used. • access—On an access port, specify the VLAN as an access VLAN. • voice—On an access port, specify the VLAN as a voice VLAN. <p>Note The voice keyword is available only if a voice VLAN is configured on a port and if that port is not the access VLAN.</p>
Step 11	end	Return to privileged EXEC mode.
Step 12	show port-security	Verify your entries.
Step 13	copy running-config startup-config	(Optional) Save your entries in the configuration file.

To return the interface to the default condition as not a secure port, use the **no switchport port-security** interface configuration command. If you enter this command when sticky learning is enabled, the sticky secure addresses remain part of the running configuration but are removed from the address table. All addresses are now dynamically learned.

To return the interface to the default number of secure MAC addresses, use the **no switchport port-security maximum value** interface configuration command. To return the violation mode to the default condition (shutdown mode), use the **no switchport port-security violation {protocol | restrict}** interface configuration command.

To disable sticky learning on an interface, use the **no switchport port-security mac-address sticky** interface configuration command. The interface converts the sticky secure MAC addresses to dynamic secure addresses. However, if you have previously saved the configuration with the sticky MAC addresses, you should save the configuration again after entering the **no switchport port-security mac-address sticky** command, or the sticky addresses will be restored if the switch reboots.

Use the **clear port-security {all | configured | dynamic | sticky}** privileged EXEC command to delete from the MAC address table all secure addresses or all secure addresses of a specific type (configured, dynamic, or sticky) on the switch or on an interface.

To delete a specific secure MAC address from the address table, use the **no switchport port-security mac-address mac-address** interface configuration command. To delete all dynamic secure addresses on an interface from the address table, enter the **no switchport port-security** interface configuration command followed by the **switchport port-security** command (to re-enable port security on the interface). If you use the **no switchport port-security mac-address sticky** interface configuration command to convert sticky secure MAC addresses to dynamic secure MAC addresses before entering the **no switchport port-security** command, all secure addresses on the interface except those that were manually configured are deleted.

You must specifically delete configured secure MAC addresses from the address table by using the **no switchport port-security mac-address mac-address** interface configuration command.

This example shows how to enable port security on a port and to set the maximum number of secure addresses to 50. The violation mode is the default, no static secure MAC addresses are configured, and sticky learning is enabled.

```
Switch(config)# interface gigabitethernet0/1
Switch(config-if)# switchport mode access
Switch(config-if)# switchport port-security
Switch(config-if)# switchport port-security maximum 50
Switch(config-if)# switchport port-security mac-address sticky
```

This example shows how to configure a static secure MAC address on VLAN 3 on a port:

```
Switch(config)# interface gigabitethernet0/2
Switch(config-if)# switchport mode trunk
Switch(config-if)# switchport port-security
Switch(config-if)# switchport port-security mac-address 0000.02000.0004 vlan 3
```

This example shows how to enable sticky port security on a port, to manually configure MAC addresses for data VLAN and voice VLAN, and to set the total maximum number of secure addresses to 20 (10 for data VLAN and 10 for voice VLAN).

```
Switch(config)# interface FastEthernet0/1
Switch(config-if)# switchport access vlan 21
Switch(config-if)# switchport mode access
Switch(config-if)# switchport voice vlan 22
Switch(config-if)# switchport port-security
Switch(config-if)# switchport port-security maximum 20
Switch(config-if)# switchport port-security violation restrict
Switch(config-if)# switchport port-security mac-address sticky
Switch(config-if)# switchport port-security mac-address sticky 0000.0000.0002
Switch(config-if)# switchport port-security mac-address 0000.0000.0003
Switch(config-if)# switchport port-security mac-address sticky 0000.0000.0001 vlan voice
Switch(config-if)# switchport port-security mac-address 0000.0000.0004 vlan voice
Switch(config-if)# switchport port-security maximum 10 vlan access
Switch(config-if)# switchport port-security maximum 10 vlan voice
```

Enabling and Configuring Port Security Aging

You can use port security aging to set the aging time for all secure addresses on a port. Two types of aging are supported per port:

- Absolute—The secure addresses on the port are deleted after the specified aging time.
- Inactivity—The secure addresses on the port are deleted only if the secure addresses are inactive for the specified aging time.

Use this feature to remove and add devices on a secure port without manually deleting the existing secure MAC addresses and to still limit the number of secure addresses on a port. You can enable or disable the aging of secure addresses on a per-port basis.

Beginning in privileged EXEC mode, follow these steps to configure port security aging:

	Command	Purpose
Step 1	<code>configure terminal</code>	Enter global configuration mode.
Step 2	<code>interface interface-id</code>	Specify the interface to be configured, and enter interface configuration mode.

	Command	Purpose
Step 3	<code>switchport port-security aging {static time <i>time</i> type {absolute inactivity}}</code>	<p>Enable or disable static aging for the secure port, or set the aging time or type.</p> <p>Note The switch does not support port security aging of sticky secure addresses.</p> <p>Enter static to enable aging for statically configured secure addresses on this port.</p> <p>For <i>time</i>, specify the aging time for this port. The valid range is from 0 to 1440 minutes.</p> <p>For type, select one of these keywords:</p> <ul style="list-style-type: none"> • absolute—Sets the aging type as absolute aging. All the secure addresses on this port age out exactly after the time (minutes) specified lapses and are removed from the secure address list. • inactivity—Sets the aging type as inactivity aging. The secure addresses on this port age out only if there is no data traffic from the secure source addresses for the specified time period.
Step 4	<code>end</code>	Return to privileged EXEC mode.
Step 5	<code>show port-security [interface <i>interface-id</i>] [address]</code>	Verify your entries.
Step 6	<code>copy running-config startup-config</code>	(Optional) Save your entries in the configuration file.

To disable port security aging for all secure addresses on a port, use the **no switchport port-security aging time** interface configuration command. To disable aging for only statically configured secure addresses, use the **no switchport port-security aging static** interface configuration command.

This example shows how to set the aging time as 2 hours for the secure addresses on a port:

```
Switch(config)# interface gigabitethernet0/1
Switch(config-if)# switchport port-security aging time 120
```

This example shows how to set the aging time as 2 minutes for the inactivity aging type with aging enabled for the configured secure addresses on the interface:

```
Switch(config-if)# switchport port-security aging time 2
Switch(config-if)# switchport port-security aging type inactivity
Switch(config-if)# switchport port-security aging static
```

You can verify the previous commands by entering the **show port-security interface *interface-id*** privileged EXEC command.

Displaying Port-Based Traffic Control Settings

The **show interfaces *interface-id* switchport** privileged EXEC command displays (among other characteristics) the interface traffic suppression and control configuration. The **show storm-control** and **show port-security** privileged EXEC commands display those storm control and port security settings.

To display traffic control information, use one or more of the privileged EXEC commands in [Table 19-4](#).

Table 19-4 **Commands for Displaying Traffic Control Status and Configuration**

Command	Purpose
show interfaces [<i>interface-id</i>] switchport	Displays the administrative and operational status of all switching (nonrouting) ports or the specified port, including port blocking and port protection settings.
show storm-control [<i>interface-id</i>] [broadcast multicast unicast]	Displays storm control suppression levels set on all interfaces or the specified interface for the specified traffic type or for broadcast traffic if no traffic type is entered.
show port-security [interface <i>interface-id</i>]	Displays port security settings for the switch or for the specified interface, including the maximum allowed number of secure MAC addresses for each interface, the number of secure MAC addresses on the interface, the number of security violations that have occurred, and the violation mode.
show port-security [interface <i>interface-id</i>] address	Displays all secure MAC addresses configured on all switch interfaces or on a specified interface with aging information for each address.
show port-security interface <i>interface-id</i> vlan	Displays the number of secure MAC addresses configured per VLAN on the specified interface.



CHAPTER 20

Configuring CDP

This chapter describes how to configure Cisco Discovery Protocol (CDP) on the Catalyst 2960 switch.



Note

For complete syntax and usage information for the commands used in this chapter, see the command reference for this release and the “System Management Commands” section in the *Cisco IOS Configuration Fundamentals Command Reference, Release 12.2*.

This chapter consists of these sections:

- [Understanding CDP, page 20-1](#)
- [Configuring CDP, page 20-2](#)
- [Monitoring and Maintaining CDP, page 20-4](#)

Understanding CDP

CDP is a device discovery protocol that runs over Layer 2 (the data link layer) on all Cisco-manufactured devices (routers, bridges, access servers, and switches) and allows network management applications to discover Cisco devices that are neighbors of already known devices. With CDP, network management applications can learn the device type and the Simple Network Management Protocol (SNMP) agent address of neighboring devices running lower-layer, transparent protocols. This feature enables applications to send SNMP queries to neighboring devices.

CDP runs on all media that support Subnetwork Access Protocol (SNAP). Because CDP runs over the data-link layer only, two systems that support different network-layer protocols can learn about each other.

Each CDP-configured device sends periodic messages to a multicast address, advertising at least one address at which it can receive SNMP messages. The advertisements also contain time-to-live, or holdtime information, which is the length of time a receiving device holds CDP information before discarding it. Each device also listens to the messages sent by other devices to learn about neighboring devices.

On the switch, CDP enables Network Assistant to display a graphical view of the network. The switch uses CDP to find cluster candidates and maintain information about cluster members and other devices up to three cluster-enabled devices away from the command switch by default.

The switch supports CDP Version 2.

Configuring CDP

These sections contain this configuration information:

- [Default CDP Configuration, page 20-2](#)
- [Configuring the CDP Characteristics, page 20-2](#)
- [Disabling and Enabling CDP, page 20-3](#)
- [Disabling and Enabling CDP on an Interface, page 20-4](#)

Default CDP Configuration

Table 20-1 shows the default CDP configuration.

Table 20-1 Default CDP Configuration

Feature	Default Setting
CDP global state	Enabled
CDP interface state	Enabled
CDP timer (packet update frequency)	60 seconds
CDP holdtime (before discarding)	180 seconds
CDP Version-2 advertisements	Enabled

Configuring the CDP Characteristics

You can configure the frequency of CDP updates, the amount of time to hold the information before discarding it, and whether or not to send Version-2 advertisements.

Beginning in privileged EXEC mode, follow these steps to configure the CDP timer, holdtime, and advertisement type.



Note

Steps 2 through 4 are all optional and can be performed in any order.

	Command	Purpose
Step 1	<code>configure terminal</code>	Enter global configuration mode.
Step 2	<code>cdp timer seconds</code>	(Optional) Set the transmission frequency of CDP updates in seconds. The range is 5 to 254; the default is 60 seconds.
Step 3	<code>cdp holdtime seconds</code>	(Optional) Specify the amount of time a receiving device should hold the information sent by your device before discarding it. The range is 10 to 255 seconds; the default is 180 seconds.
Step 4	<code>cdp advertise-v2</code>	(Optional) Configure CDP to send Version-2 advertisements. This is the default state.
Step 5	<code>end</code>	Return to privileged EXEC mode.

	Command	Purpose
Step 6	<code>show cdp</code>	Verify your settings.
Step 7	<code>copy running-config startup-config</code>	(Optional) Save your entries in the configuration file.

Use the **no** form of the CDP commands to return to the default settings.

This example shows how to configure CDP characteristics.

```
Switch# configure terminal
Switch(config)# cdp timer 50
Switch(config)# cdp holdtime 120
Switch(config)# cdp advertise-v2
Switch(config)# end
```

For additional CDP **show** commands, see the “[Monitoring and Maintaining CDP](#)” section on page 20-4.

Disabling and Enabling CDP

CDP is enabled by default.



Note

Switch clusters and other Cisco devices (such as Cisco IP Phones) regularly exchange CDP messages. Disabling CDP can interrupt cluster discovery and device connectivity. For more information, see [Chapter 5, “Clustering Switches”](#) and see *Getting Started with Cisco Network Assistant*, available on Cisco.com.

Beginning in privileged EXEC mode, follow these steps to disable the CDP device discovery capability:

	Command	Purpose
Step 1	<code>configure terminal</code>	Enter global configuration mode.
Step 2	<code>no cdp run</code>	Disable CDP.
Step 3	<code>end</code>	Return to privileged EXEC mode.

Beginning in privileged EXEC mode, follow these steps to enable CDP when it has been disabled:

	Command	Purpose
Step 1	<code>configure terminal</code>	Enter global configuration mode.
Step 2	<code>cdp run</code>	Enable CDP after disabling it.
Step 3	<code>end</code>	Return to privileged EXEC mode.

This example shows how to enable CDP if it has been disabled.

```
Switch# configure terminal
Switch(config)# cdp run
Switch(config)# end
```

Disabling and Enabling CDP on an Interface

CDP is enabled by default on all supported interfaces to send and to receive CDP information.

Beginning in privileged EXEC mode, follow these steps to disable CDP on a port:

	Command	Purpose
Step 1	configure terminal	Enter global configuration mode.
Step 2	interface <i>interface-id</i>	Specify the interface on which you are disabling CDP, and enter interface configuration mode.
Step 3	no cdp enable	Disable CDP on the interface.
Step 4	end	Return to privileged EXEC mode.
Step 5	copy running-config startup-config	(Optional) Save your entries in the configuration file.

Beginning in privileged EXEC mode, follow these steps to enable CDP on a port when it has been disabled:

	Command	Purpose
Step 1	configure terminal	Enter global configuration mode.
Step 2	interface <i>interface-id</i>	Specify the interface on which you are enabling CDP, and enter interface configuration mode.
Step 3	cdp enable	Enable CDP on the interface after disabling it.
Step 4	end	Return to privileged EXEC mode.
Step 5	copy running-config startup-config	(Optional) Save your entries in the configuration file.

This example shows how to enable CDP on a port when it has been disabled.

```
Switch# configure terminal
Switch(config)# interface gigabitethernet0/1
Switch(config-if)# cdp enable
Switch(config-if)# end
```

Monitoring and Maintaining CDP

To monitor and maintain CDP on your device, perform one or more of these tasks, beginning in privileged EXEC mode.

Command	Description
clear cdp counters	Reset the traffic counters to zero.
clear cdp table	Delete the CDP table of information about neighbors.
show cdp	Display global information, such as frequency of transmissions and the holdtime for packets being sent.

Command	Description
show cdp entry <i>entry-name</i> [protocol version]	Display information about a specific neighbor. You can enter an asterisk (*) to display all CDP neighbors, or you can enter the name of the neighbor about which you want information. You can also limit the display to information about the protocols enabled on the specified neighbor or information about the version of software running on the device.
show cdp interface [<i>interface-id</i>]	Display information about interfaces where CDP is enabled. You can limit the display to the interface about which you want information.
show cdp neighbors [<i>interface-id</i>] [detail]	Display information about neighbors, including device type, interface type and number, holdtime settings, capabilities, platform, and port ID. You can limit the display to neighbors of a specific interface or expand the display to provide more detailed information.
show cdp traffic	Display CDP counters, including the number of packets sent and received and checksum errors.



CHAPTER 21

Configuring LLDP and LLDP-MED

This chapter describes how to configure the Link Layer Discovery Protocol (LLDP) and LLDP Media Endpoint Discovery (LLDP-MED) on the Catalyst 2960 switch. Unless otherwise noted, the term *switch* refers to a standalone switch and to a switch stack.



Note

For complete syntax and usage information for the commands used in this chapter, see the command reference for this release and the “System Management Commands” section in the *Cisco IOS Configuration Fundamentals Command Reference, Release 12.2*.

This chapter consists of these sections:

- [Understanding LLDP and LLDP-MED, page 21-1](#)
- [Configuring LLDP and LLDP-MED, page 21-3](#)
- [Monitoring and Maintaining LLDP and LLDP-MED, page 21-7](#)

Understanding LLDP and LLDP-MED

This section contains this conceptual information:

- [Understanding LLDP, page 21-1](#)
- [Understanding LLDP-MED, page 21-2](#)

Understanding LLDP

The Cisco Discovery Protocol (CDP) is a device discovery protocol that runs over Layer 2 (the data link layer) on all Cisco-manufactured devices (routers, bridges, access servers, and switches). CDP allows network management applications to automatically discover and learn about other Cisco devices connected to the network.

To support non-Cisco devices and to allow for interoperability between other devices, the switch supports the IEEE 802.1AB Link Layer Discovery Protocol (LLDP). LLDP is a neighbor discovery protocol that is used for network devices to advertise information about themselves to other devices on the network. This protocol runs over the data-link layer, which allows two systems running different network layer protocols to learn about each other.

LLDP supports a set of attributes that it uses to discover neighbor devices. These attributes contain type, length, and value descriptions and are referred to as TLVs. LLDP supported devices can use TLVs to receive and send information to their neighbors. Details such as configuration information, device capabilities, and device identity can be advertised using this protocol.

The switch supports these basic management TLVs. These are mandatory LLDP TLVs.

- Port description TLV
- System name TLV
- System description TLV
- System capabilities TLV
- Management address TLV

These organizationally specific LLDP TLVs are also advertised to support LLDP-MED.

- Port VLAN ID TLV ((IEEE 802.1 organizationally specific TLVs)
- MAC/PHY configuration/status TLV(IEEE 802.3 organizationally specific TLVs)



Note

A switch stack appears as a single switch in the network. Therefore, LLDP discovers the switch stack, not the individual stack members.

Understanding LLDP-MED

LLDP for Media Endpoint Devices (LLDP-MED) is an extension to LLDP that operates between endpoint devices such as IP phones and network devices such as switches. It specifically provides support for voice over IP (VoIP) applications and provides additional TLVs for capabilities discovery, network policy, Power over Ethernet, inventory management and location information. By default, all LLDP-MED TLVs are enabled.

LLDP-MED supports these TLVs:

- LLDP-MED capabilities TLV

Allows LLDP-MED endpoints to determine the capabilities that the connected device supports and what capabilities the device has enabled.
- Network policy TLV

Allows both network connectivity devices and endpoints to advertise VLAN configurations and associated Layer 2 and Layer 3 attributes for the specific application on that port. For example, the switch can notify a phone of the VLAN number that it should use. The phone can connect into any switch, obtain its VLAN number, and then start communicating with the call control
- Power management TLV

Enables advanced power management between LLDP-MED endpoint and network connectivity devices. Allows switches and phones to convey power information, such as how the device is powered, power priority, and how much power the device needs.

- Inventory management TLV

Allows an endpoint to send detailed inventory information about itself to the switch, including information hardware revision, firmware version, software version, serial number, manufacturer name, model name, and asset ID TLV.

- Location TLV

Provides location information from the switch to the endpoint device. The location TLV can send this information:

- Civic location information

Provides the civic address information and postal information. Examples of civic location information are street address, road name, and postal community name information.

- ELIN location information

Provides the location information of a caller. The location is determined by the Emergency location identifier number (ELIN), which is a phone number that routes an emergency call to the local public safety answering point (PSAP) and which the PSAP can use to call back the emergency caller.

Note

LLDP and LLDP-MED cannot operate simultaneously in a network. By default, a network device sends only LLDP packets until it receives LLDP-MED packets from an endpoint device. The network device then sends LLDP-MED packets until it receives only LLDP packets.

Configuring LLDP and LLDP-MED

This section contains this configuration information:

- [Default LLDP Configuration, page 21-3](#)
- [Configuring LLDP Characteristics, page 21-4](#)
- [Disabling and Enabling LLDP Globally, page 21-5](#)
- [Disabling and Enabling LLDP on an Interface, page 21-5](#)
- [Configuring LLDP-MED TLVs, page 21-6](#)

Default LLDP Configuration

Table 21-1 shows the default LLDP configuration. To change the default settings, use the LLDP global configuration and LLDP interface configuration commands.

Table 21-1 **Default LLDP Configuration**

Feature	Default Setting
LLDP global state	Enabled
LLDP holdtime (before discarding)	120 seconds
LLDP timer (packet update frequency)	30 seconds
LLDP reinitialization delay	2 seconds
LLDP tlv-select	Enabled to send and receive all TLVs.

Table 21-1 Default LLDP Configuration

Feature	Default Setting
LLDP interface state	Enabled
LLDP receive	Enabled
LLDP transmit	Enabled
LLDP med-tlv-select	Enabled to send all LLDP-MED TLVs

Configuring LLDP Characteristics

You can configure the frequency of LLDP updates, the amount of time to hold the information before discarding it, and the initialization delay time. You can also select the LLDP and LLDP-MED TLVs to be sent and received.

Beginning in privileged EXEC mode, follow these steps to configure these characteristics:

Note

Steps 2 through 5 are all optional and can be performed in any order.

	Command	Purpose
Step 1	<code>configure terminal</code>	Enter global configuration mode.
Step 2	<code>lldp holdtime seconds</code>	(Optional) Specify the amount of time a receiving device should hold the information sent by your device before discarding it. The range is 0 to 65535 seconds; the default is 120 seconds.
Step 3	<code>lldp reinit</code>	(Optional) Specify the delay time in seconds for LLDP to initialize on any interface. The range is 2 to 5 seconds; the default is 2 seconds.
Step 4	<code>lldp timer seconds</code>	(Optional) Set the transmission frequency of LLDP updates in seconds. The range is 5 to 65534 seconds; the default is 30 seconds.
Step 5ll	<code>lldp tlv-select</code>	(Optional) Specify the LLDP TLVs to send or receive.
Step 6	<code>lldp med-tlv-select</code>	(Optional) Specify the LLDP-MED TLVs to send or receive.
Step 7	<code>copy running-config startup-config</code>	(Optional) Save your entries in the configuration file.

Use the **no** form of each of the LLDP commands to return to the default setting.

This example shows how to configure LLDP characteristics.

```
Switch# configure terminal
Switch(config)# lldp holdtime 120
Switch(config)# lldp reinit 2
Switch(config)# lldp timer 30
Switch(config)# end
```

For additional LLDP **show** commands, see the [“Monitoring and Maintaining LLDP and LLDP-MED”](#) section on page 21-7.

Disabling and Enabling LLDP Globally

LLDP is enabled by default.

Beginning in privileged EXEC mode, follow these steps to globally disable LLDP:

	Command	Purpose
Step 1	<code>configure terminal</code>	Enter global configuration mode.
Step 2	<code>no lldp run</code>	Disable LLDP.
Step 3	<code>end</code>	Return to privileged EXEC mode.

Beginning in privileged EXEC mode, follow these steps to enable LLDP-MED when it has been disabled:

	Command	Purpose
Step 1	<code>configure terminal</code>	Enter global configuration mode.
Step 2	<code>lldp run</code>	Enable LLDP.
Step 3	<code>end</code>	Return to privileged EXEC mode.

This example shows how to globally disable LLDP.

```
Switch# configure terminal
Switch(config)# no lldp run
Switch(config)# end
```

This example shows how to globally enable LLDP.

```
Switch# configure terminal
Switch(config)# lldp run
Switch(config)# end
```

Disabling and Enabling LLDP on an Interface

LLDP is enabled by default on all supported interfaces to send and to receive LLDP information.



Note

If the interface is configured as a tunnel port, LLDP is automatically disabled.

Beginning in privileged EXEC mode, follow these steps to disable LLDP on an interface.

	Command	Purpose
Step 1	<code>configure terminal</code>	Enter global configuration mode.
Step 2	<code>interface interface-id</code>	Specify the interface on which you are disabling LLDP, and enter interface configuration mode.
Step 3	<code>no lldp transmit</code>	No LLDP packets are sent on the interface.
Step 4	<code>no lldp receive</code>	No LLDP packets are received on the interface.

	Command	Purpose
Step 5	end	Return to privileged EXEC mode.
Step 6	copy running-config startup-config	(Optional) Save your entries in the configuration file.

Beginning in privileged EXEC mode, follow these steps to enable LLDP on an interface when it has been disabled:

	Command	Purpose
Step 1	configure terminal	Enter global configuration mode.
Step 2	interface <i>interface-id</i>	Specify the interface on which you are enabling LLDP-MED, and enter interface configuration mode.
Step 3	lldp transmit	LLDP packets are sent on the interface.
Step 4	lldp receive	LLDP packets are received on the interface.
Step 5	end	Return to privileged EXEC mode.
Step 6	copy running-config startup-config	(Optional) Save your entries in the configuration file.

This example shows how to enable LLDP on an interface.

```
Switch# configure terminal
Switch(config)# interface GigabitEthernet0/1
Switch(config-if)# lldp transmit
Switch(config-if)# lldp receive
Switch(config-if)# end
```

Configuring LLDP-MED TLVs

By default, the switch only sends LLDP packets until it receives LLDP-MED packets from the end device. The device continues to send LLDP-MED packets until it only receives LLDP packets.

By using the **lldp** interface configuration command, you can configure the interface not to send the TLVs listed in [Table 21-2](#).

Table 21-2 LLDP-MED TLVs

LLDP-MED TLV	Description
inventory-management	LLDP-MED inventory management TLV
location	LLDP-MED location TLV
network-policy	LLDP-MED network policy TLV
power-management	LLDP-MED power management TLV

Beginning in privileged EXEC mode, follow these steps to disable a TLV on an interface:

	Command	Purpose
Step 1	configure terminal	Enter global configuration mode.
Step 2	interface <i>interface-id</i>	Specify the interface on which you are configuring a LLDP-MED TLV, and enter interface configuration mode.
Step 3	no lldp med-tlv-select <i>tlv</i>	Specify the TLV to disable.
Step 4	end	Return to privileged EXEC mode.
Step 5	copy running-config startup-config	(Optional) Save your entries in the configuration file.

Beginning in privileged EXEC mode, follow these steps to enable a TLV on an interface:

	Command	Purpose
Step 1	configure terminal	Enter global configuration mode.
Step 2	interface <i>interface-id</i>	Specify the interface on which you are configuring an LLDP-MED TLV, and enter interface configuration mode.
Step 3	lldp med-tlv-select <i>tlv</i>	Specify the TLV to enable.
Step 4	end	Return to privileged EXEC mode.
Step 5	copy running-config startup-config	(Optional) Save your entries in the configuration file.

This example shows how to enable a TLV on an interface when it has been disabled.

```
Switch# configure terminal
Switch(config)# interface GigabitEthernet0/1
Switch(config-if)# lldp med-tlv-select inventory management
Switch(config-if)# end
```

Monitoring and Maintaining LLDP and LLDP-MED

To monitor and maintain LLDP and LLDP-MED on your device, perform one or more of these tasks, beginning in privileged EXEC mode.

Command	Description
clear lldp counters	Reset the traffic counters to zero.
clear lldp table	Delete the LLDP table of information about neighbors.
show lldp	Display global information, such as frequency of transmissions, the holdtime for packets being sent, and the delay time for LLDP to initialize on an interface.
show lldp entry <i>entry-name</i>	Display information about a specific neighbor. You can enter an asterisk (*) to display all neighbors, or you can enter the name of the neighbor about which you want information.
show lldp interface [<i>interface-id</i>]	Display information about interfaces where LLDP is enabled. You can limit the display to the interface about which you want information.

Command	Description
show lldp neighbors [<i>interface-id</i>] [detail]	Display information about neighbors, including device type, interface type and number, holdtime settings, capabilities, and port ID. You can limit the display to neighbors of a specific interface or expand the display to provide more detailed information.
show lldp traffic	Display LLDP counters, including the number of packets sent and received, number of packets discarded, and number of unrecognized TLVs.



CHAPTER 22

Configuring UDLD

This chapter describes how to configure the UniDirectional Link Detection (UDLD) protocol on the Catalyst 2960 switch.



Note

For complete syntax and usage information for the commands used in this chapter, see the command reference for this release.

This chapter consists of these sections:

- [Understanding UDLD, page 22-1](#)
- [Configuring UDLD, page 22-4](#)
- [Displaying UDLD Status, page 22-6](#)

Understanding UDLD

UDLD is a Layer 2 protocol that enables devices connected through fiber-optic or twisted-pair Ethernet cables to monitor the physical configuration of the cables and detect when a unidirectional link exists. All connected devices must support UDLD for the protocol to successfully identify and disable unidirectional links. When UDLD detects a unidirectional link, it disables the affected port and alerts you. Unidirectional links can cause a variety of problems, including spanning-tree topology loops.

Modes of Operation

UDLD supports two modes of operation: normal (the default) and aggressive. In normal mode, UDLD can detect unidirectional links due to misconnected ports on fiber-optic connections. In aggressive mode, UDLD can also detect unidirectional links due to one-way traffic on fiber-optic and twisted-pair links and to misconnected ports on fiber-optic links.

In normal and aggressive modes, UDLD works with the Layer 1 mechanisms to learn the physical status of a link. At Layer 1, autonegotiation takes care of physical signaling and fault detection. UDLD performs tasks that autonegotiation cannot perform, such as detecting the identities of neighbors and shutting down misconnected ports. When you enable both autonegotiation and UDLD, the Layer 1 and Layer 2 detections work together to prevent physical and logical unidirectional connections and the malfunctioning of other protocols.

A unidirectional link occurs whenever traffic sent by a local device is received by its neighbor but traffic from the neighbor is not received by the local device.

In normal mode, UDLD detects a unidirectional link when fiber strands in a fiber-optic port are misconnected and the Layer 1 mechanisms do not detect this misconnection. If the ports are connected correctly but the traffic is one way, UDLD does not detect the unidirectional link because the Layer 1 mechanism, which is supposed to detect this condition, does not do so. In this case, the logical link is considered undetermined, and UDLD does not disable the port.

When UDLD is in normal mode, if one of the fiber strands in a pair is disconnected and autonegotiation is active, the link does not stay up because the Layer 1 mechanisms did not detect a physical problem with the link. In this case, UDLD does not take any action, and the logical link is considered undetermined.

In aggressive mode, UDLD detects a unidirectional link by using the previous detection methods. UDLD in aggressive mode can also detect a unidirectional link on a point-to-point link on which no failure between the two devices is allowed. It can also detect a unidirectional link when one of these problems exists:

- On fiber-optic or twisted-pair links, one of the ports cannot send or receive traffic.
- On fiber-optic or twisted-pair links, one of the ports is down while the other is up.
- One of the fiber strands in the cable is disconnected.

In these cases, UDLD disables the affected port.

In a point-to-point link, UDLD hello packets can be considered as a heart beat whose presence guarantees the health of the link. Conversely, the loss of the heart beat means that the link must be shut down if it is not possible to re-establish a bidirectional link.

If both fiber strands in a cable are working normally from a Layer 1 perspective, UDLD in aggressive mode detects whether those fiber strands are connected correctly and whether traffic is flowing bidirectionally between the correct neighbors. This check cannot be performed by autonegotiation because autonegotiation operates at Layer 1.

Methods to Detect Unidirectional Links

UDLD operates by using two mechanisms:

- Neighbor database maintenance

UDLD learns about other UDLD-capable neighbors by periodically sending a hello packet (also called an advertisement or probe) on every active port to keep each device informed about its neighbors.

When the switch receives a hello message, it caches the information until the age time (hold time or time-to-live) expires. If the switch receives a new hello message before an older cache entry ages, the switch replaces the older entry with the new one.

Whenever a port is disabled and UDLD is running, whenever UDLD is disabled on a port, or whenever the switch is reset, UDLD clears all existing cache entries for the ports affected by the configuration change. UDLD sends at least one message to inform the neighbors to flush the part of their caches affected by the status change. The message is intended to keep the caches synchronized.

- Event-driven detection and echoing

UDLD relies on echoing as its detection mechanism. Whenever a UDLD device learns about a new neighbor or receives a resynchronization request from an out-of-sync neighbor, it restarts the detection window on its side of the connection and sends echo messages in reply. Because this behavior is the same on all UDLD neighbors, the sender of the echoes expects to receive an echo in reply.

If the detection window ends and no valid reply message is received, the link might shut down, depending on the UDLD mode. When UDLD is in normal mode, the link might be considered undetermined and might not be shut down. When UDLD is in aggressive mode, the link is considered unidirectional, and the port is disabled.

If UDLD in normal mode is in the advertisement or in the detection phase and all the neighbor cache entries are aged out, UDLD restarts the link-up sequence to resynchronize with any potentially out-of-sync neighbors.

If you enable aggressive mode when all the neighbors of a port have aged out either in the advertisement or in the detection phase, UDLD restarts the link-up sequence to resynchronize with any potentially out-of-sync neighbor. UDLD shuts down the port if, after the fast train of messages, the link state is still undetermined.

Figure 22-1 shows an example of a unidirectional link condition.

Figure 22-1 UDLD Detection of a Unidirectional Link

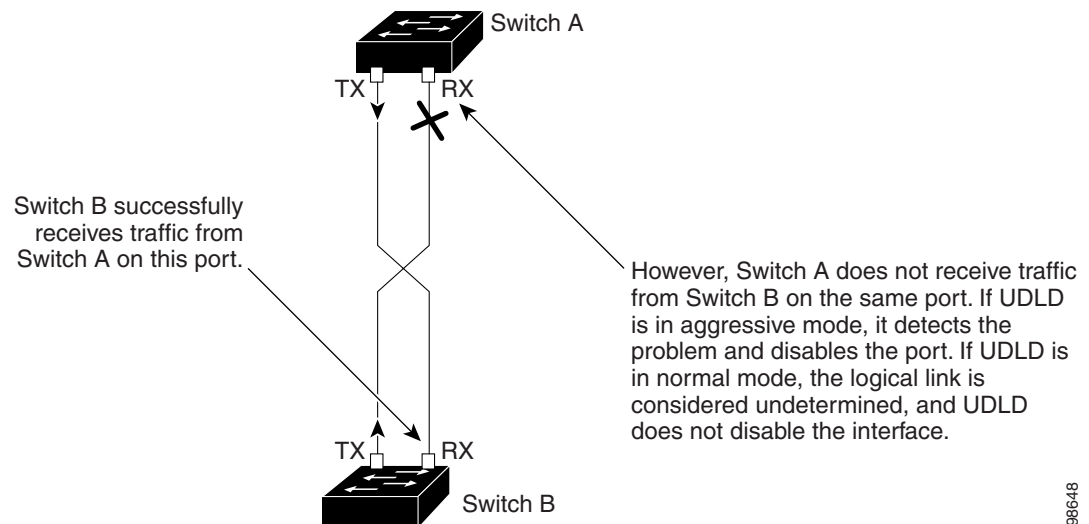

98648

Configuring UDLD

These sections contain this configuration information:

- [Default UDLD Configuration, page 22-4](#)
- [Configuration Guidelines, page 22-4](#)
- [Enabling UDLD Globally, page 22-5](#)
- [Enabling UDLD on an Interface, page 22-5](#)
- [Resetting an Interface Disabled by UDLD, page 22-6](#)

Default UDLD Configuration

[Table 22-1](#) shows the default UDLD configuration.

Table 22-1 *Default UDLD Configuration*

Feature	Default Setting
UDLD global enable state	Globally disabled
UDLD per-port enable state for fiber-optic media	Disabled on all Ethernet fiber-optic ports
UDLD per-port enable state for twisted-pair (copper) media	Disabled on all Ethernet 10/100 and 1000BASE-TX ports
UDLD aggressive mode	Disabled

Configuration Guidelines

These are the UDLD configuration guidelines:

- UDLD is not supported on ATM ports.
- A UDLD-capable port cannot detect a unidirectional link if it is connected to a UDLD-incapable port of another switch.
- When configuring the mode (normal or aggressive), make sure that the same mode is configured on both sides of the link.



Caution

Loop guard works only on point-to-point links. We recommend that each end of the link has a directly connected device that is running STP.

Enabling UDLD Globally

Beginning in privileged EXEC mode, follow these steps to enable UDLD in the aggressive or normal mode and to set the configurable message timer on all fiber-optic ports on the switch:

	Command	Purpose
Step 1	configure terminal	Enter global configuration mode.
Step 2	udld { aggressive enable message time <i>message-timer-interval</i> }	Specify the UDLD mode of operation: <ul style="list-style-type: none"> • aggressive—Enables UDLD in aggressive mode on all fiber-optic ports. • enable—Enables UDLD in normal mode on all fiber-optic ports on the switch. UDLD is disabled by default. An individual interface configuration overrides the setting of the udld enable global configuration command. For more information about aggressive and normal modes, see the “Modes of Operation” section on page 22-1. • message time <i>message-timer-interval</i>—Configures the period of time between UDLD probe messages on ports that are in the advertisement phase and are detected to be bidirectional. The range is from 7 to 90 seconds. <p>Note This command affects fiber-optic ports only. Use the udld interface configuration command to enable UDLD on other port types. For more information, see the “Enabling UDLD on an Interface” section on page 22-5.</p>
Step 3	end	Return to privileged EXEC mode.
Step 4	show udld	Verify your entries.
Step 5	copy running-config startup-config	(Optional) Save your entries in the configuration file.

To disable UDLD globally, use the **no udld enable** global configuration command to disable normal mode UDLD on all fiber-optic ports. Use the **no udld aggressive** global configuration command to disable aggressive mode UDLD on all fiber-optic ports.

Enabling UDLD on an Interface

Beginning in privileged EXEC mode, follow these steps either to enable UDLD in the aggressive or normal mode or to disable UDLD on a port:

	Command	Purpose
Step 1	configure terminal	Enter global configuration mode.
Step 2	interface <i>interface-id</i>	Specify the port to be enabled for UDLD, and enter interface configuration mode.

	Command	Purpose
Step 3	udld port [aggressive]	UDLD is disabled by default. <ul style="list-style-type: none"> • udld port—Enables UDLD in normal mode on the specified port. • udld port aggressive—Enables UDLD in aggressive mode on the specified port. <p>Note Use the no udld port interface configuration command to disable UDLD on a specified fiber-optic port.</p> <p>For more information about aggressive and normal modes, see the “Modes of Operation” section on page 22-1.</p>
Step 4	end	Return to privileged EXEC mode.
Step 5	show udld <i>interface-id</i>	Verify your entries.
Step 6	copy running-config startup-config	(Optional) Save your entries in the configuration file.

Resetting an Interface Disabled by UDLD

Beginning in privileged EXEC mode, follow these steps to reset all ports disabled by UDLD:

	Command	Purpose
Step 1	udld reset	Reset all ports disabled by UDLD.
Step 2	show udld	Verify your entries.

You can also bring up the port by using these commands:

- The **shutdown** interface configuration command followed by the **no shutdown** interface configuration command restarts the disabled port.
- The **no udld {aggressive | enable}** global configuration command followed by the **udld {aggressive | enable}** global configuration command re-enables the disabled ports.
- The **no udld port** interface configuration command followed by the **udld port [aggressive]** interface configuration command re-enables the disabled fiber-optic port.
- The **errdisable recovery cause udld** global configuration command enables the timer to automatically recover from the UDLD error-disabled state, and the **errdisable recovery interval interval** global configuration command specifies the time to recover from the UDLD error-disabled state.

Displaying UDLD Status

To display the UDLD status for the specified port or for all ports, use the **show udld** [*interface-id*] privileged EXEC command.

For detailed information about the fields in the command output, see the command reference for this release.



CHAPTER 23

Configuring SPAN and RSPAN

This chapter describes how to configure Switched Port Analyzer (SPAN) and Remote SPAN (RSPAN) on the Catalyst 2960 switch.

**Note**

For complete syntax and usage information for the commands used in this chapter, see the command reference for this release.

This chapter consists of these sections:

- [Understanding SPAN and RSPAN, page 23-1](#)
- [Configuring SPAN and RSPAN, page 23-9](#)
- [Displaying SPAN and RSPAN Status, page 23-22](#)

Understanding SPAN and RSPAN

You can analyze network traffic passing through ports or VLANs by using SPAN or RSPAN to send a copy of the traffic to another port on the switch or on another switch that has been connected to a network analyzer or other monitoring or security device. SPAN copies (or mirrors) traffic received or sent (or both) on source ports or source VLANs to a destination port for analysis. SPAN does not affect the switching of network traffic on the source ports or VLANs. You must dedicate the destination port for SPAN use. Except for traffic that is required for the SPAN or RSPAN session, destination ports do not receive or forward traffic.

Only traffic that enters or leaves source ports or traffic that enters or leaves source VLANs can be monitored by using SPAN; traffic routed to a source VLAN cannot be monitored. For example, if incoming traffic is being monitored, traffic that gets routed from another VLAN to the source VLAN cannot be monitored; however, traffic that is received on the source VLAN and routed to another VLAN can be monitored.

You can use the SPAN or RSPAN destination port to inject traffic from a network security device. For example, if you connect a Cisco Intrusion Detection System (IDS) sensor appliance to a destination port, the IDS device can send TCP reset packets to close down the TCP session of a suspected attacker.

These sections contain this conceptual information:

- [Local SPAN, page 23-2](#)
- [Remote SPAN, page 23-2](#)
- [SPAN and RSPAN Concepts and Terminology, page 23-3](#)
- [SPAN and RSPAN Interaction with Other Features, page 23-8](#)

Local SPAN

Local SPAN supports a SPAN session entirely within one switch; all source ports or source VLANs and destination ports are in the same switch. Local SPAN copies traffic from one or more source ports in any VLAN or from one or more VLANs to a destination port for analysis. For example, in [Figure 23-1](#), all traffic on port 5 (the source port) is mirrored to port 10 (the destination port). A network analyzer on port 10 receives all network traffic from port 5 without being physically attached to port 5.

Figure 23-1 Example of Local SPAN Configuration on a Single Switch

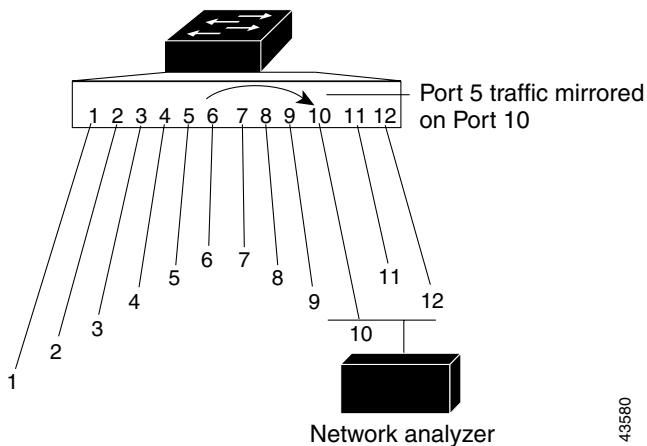

Remote SPAN

RSPAN supports source ports, source VLANs, and destination ports on different switches, enabling remote monitoring of multiple switches across your network. [Figure 23-2](#) shows source ports on Switch A and Switch B. The traffic for each RSPAN session is carried over a user-specified RSPAN VLAN that is dedicated for that RSPAN session in all participating switches. The RSPAN traffic from the source ports or VLANs is copied into the RSPAN VLAN and forwarded over trunk ports carrying the RSPAN VLAN to a destination session monitoring the RSPAN VLAN. Each RSPAN source switch must have either ports or VLANs as RSPAN sources. The destination is always a physical port, as shown on Switch C in the figure.

Figure 23-2 Example of RSPAN Configuration

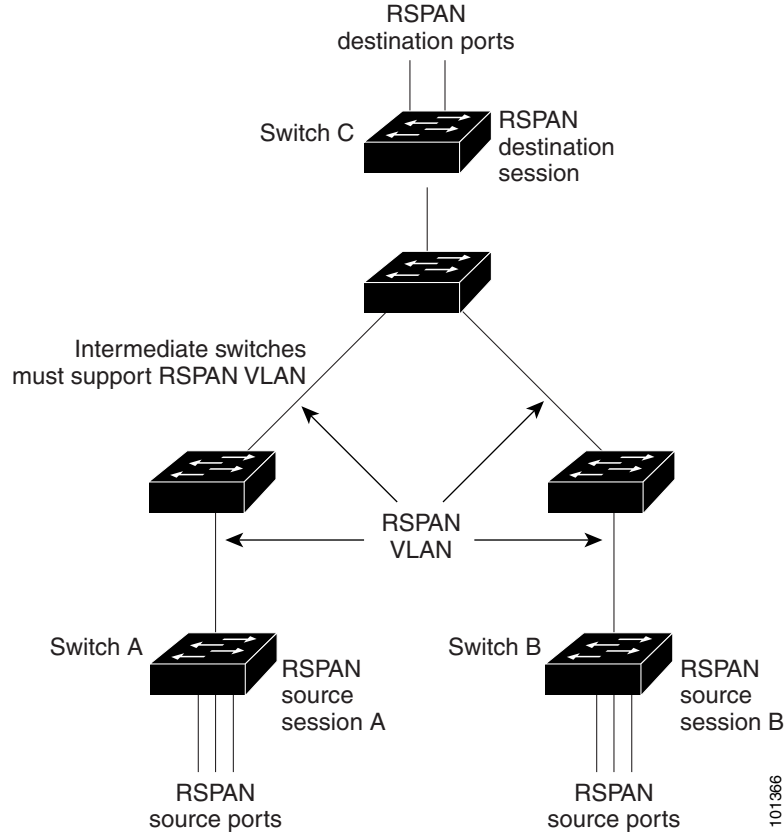

SPAN and RSPAN Concepts and Terminology

This section describes concepts and terminology associated with SPAN and RSPAN configuration.

SPAN Sessions

SPAN sessions (local or remote) allow you to monitor traffic on one or more ports, or one or more VLANs, and send the monitored traffic to one or more destination ports.

A local SPAN session is an association of a destination port with source ports or source VLANs, all on a single network device. Local SPAN does not have separate source and destination sessions. Local SPAN sessions gather a set of ingress and egress packets specified by the user and form them into a stream of SPAN data, which is directed to the destination port.

RSPAN consists of at least one RSPAN source session, an RSPAN VLAN, and at least one RSPAN destination session. You separately configure RSPAN source sessions and RSPAN destination sessions on different network devices. To configure an RSPAN source session on a device, you associate a set of source ports or source VLANs with an RSPAN VLAN. The output of this session is the stream of SPAN packets that are sent to the RSPAN VLAN. To configure an RSPAN destination session on another device, you associate the destination port with the RSPAN VLAN. The destination session collects all RSPAN VLAN traffic and sends it out the RSPAN destination port.

An RSPAN source session is very similar to a local SPAN session, except for where the packet stream is directed. In an RSPAN source session, SPAN packets are relabeled with the RSPAN VLAN ID and directed over normal trunk ports to the destination switch.

An RSPAN destination session takes all packets received on the RSPAN VLAN, strips off the VLAN tagging, and presents them on the destination port. Its purpose is to present a copy of all RSPAN VLAN packets (except Layer 2 control packets) to the user for analysis.

There can be more than one source session and more than one destination session active in the same RSPAN VLAN. There can also be intermediate switches separating the RSPAN source and destination sessions. These switches need not be capable of running RSPAN, but they must respond to the requirements of the RSPAN VLAN (see the “[RSPAN VLAN](#)” section on page 23-7).

Traffic monitoring in a SPAN session has these restrictions:

- Sources can be ports or VLANs, but you cannot mix source ports and source VLANs in the same session.
- The switch supports up to two source sessions (local SPAN and RSPAN source sessions). You can run both a local SPAN and an RSPAN source session in the same switch. The switch supports a total of 66 source and RSPAN destination sessions.
- You can have multiple destination ports in a SPAN session, but no more than 64 destination ports.
- You can configure two separate SPAN or RSPAN source sessions with separate or overlapping sets of SPAN source ports and VLANs.
- SPAN sessions do not interfere with the normal operation of the switch. However, an oversubscribed SPAN destination, for example, a 10-Mb/s port monitoring a 100-Mb/s port, can result in dropped or lost packets.
- When RSPAN is enabled, each packet being monitored is transmitted twice, once as normal traffic and once as a monitored packet. Therefore monitoring a large number of ports or VLANs could potentially generate large amounts of network traffic.
- You can configure SPAN sessions on disabled ports; however, a SPAN session does not become active unless you enable the destination port and at least one source port or VLAN for that session.
- The switch does not support a combination of local SPAN and RSPAN in a single session. That is, an RSPAN source session cannot have a local destination port, an RSPAN destination session cannot have a local source port, and an RSPAN destination session and an RSPAN source session that are using the same RSPAN VLAN cannot run on the same switch.

Monitored Traffic

SPAN sessions can monitor these traffic types:

- Receive (Rx) SPAN—The goal of receive (or ingress) SPAN is to monitor as much as possible all the packets received by the source interface or VLAN before any modification or processing is performed by the switch. A copy of each packet received by the source is sent to the destination port for that SPAN session.

Packets that are modified because of routing or quality of service (QoS)—for example, modified Differentiated Services Code Point (DSCP)—are copied before modification.

Features that can cause a packet to be dropped during receive processing have no effect on ingress SPAN; the destination port receives a copy of the packet even if the actual incoming packet is dropped. These features include IP standard and extended input access control lists (ACLs), ingress QoS policing, and egress QoS policing.

- **Transmit (Tx) SPAN**—The goal of transmit (or egress) SPAN is to monitor as much as possible all the packets sent by the source interface after all modification and processing is performed by the switch. A copy of each packet sent by the source is sent to the destination port for that SPAN session. The copy is provided after the packet is modified.

Features that can cause a packet to be dropped during transmit processing also affect the duplicated copy for SPAN. These features include IP standard and extended output ACLs and egress QoS policing.

- **Both**—In a SPAN session, you can also monitor a port or VLAN for both received and sent packets. This is the default.

The default configuration for local SPAN session ports is to send all packets untagged. SPAN also does not normally monitor bridge protocol data unit (BPDU) packets and Layer 2 protocols, such as Cisco Discovery Protocol (CDP), VLAN Trunk Protocol (VTP), Dynamic Trunking Protocol (DTP), Spanning Tree Protocol (STP), and Port Aggregation Protocol (PAgP). However, when you enter the **encapsulation replicate** keywords when configuring a destination port, these changes occur:

- Packets are sent on the destination port with the same encapsulation—untagged or IEEE 802.1Q—that they had on the source port.
- Packets of all types, including BPDU and Layer 2 protocol packets, are monitored.

Therefore, a local SPAN session with encapsulation replicate enabled can have a mixture of untagged and IEEE 802.1Q tagged packets appear on the destination port.

Switch congestion can cause packets to be dropped at ingress source ports, egress source ports, or SPAN destination ports. In general, these characteristics are independent of one another. For example:

- A packet might be forwarded normally but dropped from monitoring due to an oversubscribed SPAN destination port.
- An ingress packet might be dropped from normal forwarding, but still appear on the SPAN destination port.
- An egress packet dropped because of switch congestion is also dropped from egress SPAN.

In some SPAN configurations, multiple copies of the same source packet are sent to the SPAN destination port. For example, a bidirectional (both Rx and Tx) SPAN session is configured for the Rx monitor on port A and Tx monitor on port B. If a packet enters the switch through port A and is switched to port B, both incoming and outgoing packets are sent to the destination port. Both packets are the same.

Source Ports

A source port (also called a *monitored port*) is a switched port that you monitor for network traffic analysis. In a local SPAN session or RSPAN source session, you can monitor source ports or VLANs for traffic in one or both directions. The switch supports any number of source ports (up to the maximum number of available ports on the switch) and any number of source VLANs (up to the maximum number of VLANs supported). However, the switch supports a maximum of two sessions (local or RSPAN) with source ports or VLANs, and you cannot mix ports and VLANs in a single session.

A source port has these characteristics:

- It can be monitored in multiple SPAN sessions.
- Each source port can be configured with a direction (ingress, egress, or both) to monitor.
- It can be any port type (for example, EtherChannel, Fast Ethernet, Gigabit Ethernet, and so forth).
- For EtherChannel sources, you can monitor traffic for the entire EtherChannel or individually on a physical port as it participates in the port channel.

- It can be an access port, trunk port, or voice VLAN port.
- It cannot be a destination port.
- Source ports can be in the same or different VLANs.
- You can monitor multiple source ports in a single session.

Source VLANs

VLAN-based SPAN (VSPAN) is the monitoring of the network traffic in one or more VLANs. The SPAN or RSPAN source interface in VSPAN is a VLAN ID, and traffic is monitored on all the ports for that VLAN.

VSPAN has these characteristics:

- All active ports in the source VLAN are included as source ports and can be monitored in either or both directions.
- On a given port, only traffic on the monitored VLAN is sent to the destination port.
- If a destination port belongs to a source VLAN, it is excluded from the source list and is not monitored.
- If ports are added to or removed from the source VLANs, the traffic on the source VLAN received by those ports is added to or removed from the sources being monitored.
- You cannot use filter VLANs in the same session with VLAN sources.
- You can monitor only Ethernet VLANs.

VLAN Filtering

When you monitor a trunk port as a source port, by default, all VLANs active on the trunk are monitored. You can limit SPAN traffic monitoring on trunk source ports to specific VLANs by using VLAN filtering.

- VLAN filtering applies only to trunk ports or to voice VLAN ports.
- VLAN filtering applies only to port-based sessions and is not allowed in sessions with VLAN sources.
- When a VLAN filter list is specified, only those VLANs in the list are monitored on trunk ports or on voice VLAN access ports.
- SPAN traffic coming from other port types is not affected by VLAN filtering; that is, all VLANs are allowed on other ports.
- VLAN filtering affects only traffic forwarded to the destination SPAN port and does not affect the switching of normal traffic.

Destination Port

Each local SPAN session or RSPAN destination session must have a destination port (also called a *monitoring port*) that receives a copy of traffic from the source ports or VLANs and sends the SPAN packets to the user, usually a network analyzer.

A destination port has these characteristics:

- For a local SPAN session, the destination port must reside on the same switch as the source port. For an RSPAN session, it is located on the switch containing the RSPAN destination session. There is no destination port on a switch running only an RSPAN source session.
- When a port is configured as a SPAN destination port, the configuration overwrites the original port configuration. When the SPAN destination configuration is removed, the port reverts to its previous configuration. If a configuration change is made to the port while it is acting as a SPAN destination port, the change does not take effect until the SPAN destination configuration had been removed.
- If the port was in an EtherChannel group, it is removed from the group while it is a destination port.
- It can be any Ethernet physical port.
- It cannot be a secure port.
- It cannot be a source port.
- It cannot be an EtherChannel group or a VLAN.
- It can participate in only one SPAN session at a time (a destination port in one SPAN session cannot be a destination port for a second SPAN session).
- When it is active, incoming traffic is disabled. The port does not transmit any traffic except that required for the SPAN session. Incoming traffic is never learned or forwarded on a destination port.
- If ingress traffic forwarding is enabled for a network security device, the destination port forwards traffic at Layer 2.
- It does not participate in any of the Layer 2 protocols (STP, VTP, CDP, DTP, PagP).
- A destination port that belongs to a source VLAN of any SPAN session is excluded from the source list and is not monitored.
- The maximum number of destination ports in a switch is 64.

Local SPAN and RSPAN destination ports behave differently regarding VLAN tagging and encapsulation:

- For local SPAN, if the **encapsulation replicate** keywords are specified for the destination port, these packets appear with the original encapsulation (untagged or IEEE 802.1Q). If these keywords are not specified, packets appear in the untagged format. Therefore, the output of a local SPAN session with **encapsulation replicate** enabled can contain a mixture of untagged or IEEE 802.1Q-tagged packets.
- For RSPAN, the original VLAN ID is lost because it is overwritten by the RSPAN VLAN identification. Therefore, all packets appear on the destination port as untagged.

RSPAN VLAN

The RSPAN VLAN carries SPAN traffic between RSPAN source and destination sessions. It has these special characteristics:

- All traffic in the RSPAN VLAN is always flooded.
- No MAC address learning occurs on the RSPAN VLAN.
- RSPAN VLAN traffic only flows on trunk ports.
- RSPAN VLANs must be configured in VLAN configuration mode by using the **remote-span** VLAN configuration mode command.
- STP can run on RSPAN VLAN trunks but not on SPAN destination ports.

For VLANs 1 to 1005 that are visible to VLAN Trunking Protocol (VTP), the VLAN ID and its associated RSPAN characteristic are propagated by VTP. If you assign an RSPAN VLAN ID in the extended VLAN range (1006 to 4094), you must manually configure all intermediate switches.

It is normal to have multiple RSPAN VLANs in a network at the same time with each RSPAN VLAN defining a network-wide RSPAN session. That is, multiple RSPAN source sessions anywhere in the network can contribute packets to the RSPAN session. It is also possible to have multiple RSPAN destination sessions throughout the network, monitoring the same RSPAN VLAN and presenting traffic to the user. The RSPAN VLAN ID separates the sessions.

SPAN and RSPAN Interaction with Other Features

SPAN interacts with these features:

- **STP**—A destination port does not participate in STP while its SPAN or RSPAN session is active. The destination port can participate in STP after the SPAN or RSPAN session is disabled. On a source port, SPAN does not affect the STP status. STP can be active on trunk ports carrying an RSPAN VLAN.
- **CDP**—A SPAN destination port does not participate in CDP while the SPAN session is active. After the SPAN session is disabled, the port again participates in CDP.
- **VTP**—You can use VTP to prune an RSPAN VLAN between switches.
- **VLAN and trunking**—You can modify VLAN membership or trunk settings for source or destination ports at any time. However, changes in VLAN membership or trunk settings for a destination port do not take effect until you remove the SPAN destination configuration. Changes in VLAN membership or trunk settings for a source port immediately take effect, and the respective SPAN sessions automatically adjust accordingly.
- **EtherChannel**—You can configure an EtherChannel group as a source port but not as a SPAN destination port. When a group is configured as a SPAN source, the entire group is monitored.

If a physical port is added to a monitored EtherChannel group, the new port is added to the SPAN source port list. If a port is removed from a monitored EtherChannel group, it is automatically removed from the source port list.

A physical port that belongs to an EtherChannel group can be configured as a SPAN source port and still be a part of the EtherChannel. In this case, data from the physical port is monitored as it participates in the EtherChannel. However, if a physical port that belongs to an EtherChannel group is configured as a SPAN destination, it is removed from the group. After the port is removed from the SPAN session, it rejoins the EtherChannel group. Ports removed from an EtherChannel group remain members of the group, but they are in the *inactive* or *suspended* state.

If a physical port that belongs to an EtherChannel group is a destination port and the EtherChannel group is a source, the port is removed from the EtherChannel group and from the list of monitored ports.

- **Multicast traffic** can be monitored. For egress and ingress port monitoring, only a single unedited packet is sent to the SPAN destination port. It does not reflect the number of times the multicast packet is sent.

- A secure port cannot be a SPAN destination port.
For SPAN sessions, do not enable port security on ports with monitored egress when ingress forwarding is enabled on the destination port. For RSPAN source sessions, do not enable port security on any ports with monitored egress.
- An IEEE 802.1x port can be a SPAN source port. You can enable IEEE 802.1x on a port that is a SPAN destination port; however, IEEE 802.1x is disabled until the port is removed as a SPAN destination.
For SPAN sessions, do not enable IEEE 802.1x on ports with monitored egress when ingress forwarding is enabled on the destination port. For RSPAN source sessions, do not enable IEEE 802.1x on any ports that are egress monitored.

Configuring SPAN and RSPAN

These sections contain this configuration information:

- [Default SPAN and RSPAN Configuration, page 23-9](#)
- [Configuring Local SPAN, page 23-9](#)
- [Configuring RSPAN, page 23-15](#)

Default SPAN and RSPAN Configuration

Table 23-1 shows the default SPAN and RSPAN configuration.

Table 23-1 *Default SPAN and RSPAN Configuration*

Feature	Default Setting
SPAN state (SPAN and RSPAN)	Disabled.
Source port traffic to monitor	Both received and sent traffic (both).
Encapsulation type (destination port)	Native form (untagged packets).
Ingress forwarding (destination port)	Disabled
VLAN filtering	On a trunk interface used as a source port, all VLANs are monitored.
RSPAN VLANs	None configured.

Configuring Local SPAN

These sections contain this configuration information:

- [SPAN Configuration Guidelines, page 23-10](#)
- [Creating a Local SPAN Session, page 23-10](#)
- [Creating a Local SPAN Session and Configuring Incoming Traffic, page 23-13](#)
- [Specifying VLANs to Filter, page 23-14](#)

SPAN Configuration Guidelines

Follow these guidelines when configuring SPAN:

- For SPAN sources, you can monitor traffic for a single port or VLAN or a series or range of ports or VLANs for each session. You cannot mix source ports and source VLANs within a single SPAN session.
- The destination port cannot be a source port; a source port cannot be a destination port.
- You cannot have two SPAN sessions using the same destination port.
- When you configure a switch port as a SPAN destination port, it is no longer a normal switch port; only monitored traffic passes through the SPAN destination port.
- Entering SPAN configuration commands does not remove previously configured SPAN parameters. You must enter the **no monitor session** {*session_number* | **all** | **local** | **remote**} global configuration command to delete configured SPAN parameters.
- For local SPAN, outgoing packets through the SPAN destination port carry the original encapsulation headers—untagged or IEEE 802.1Q—if the **encapsulation replicate** keywords are specified. If the keywords are not specified, the packets are sent in native form. For RSPAN destination ports, outgoing packets are not tagged.
- You can configure a disabled port to be a source or destination port, but the SPAN function does not start until the destination port and at least one source port or source VLAN are enabled.
- You can limit SPAN traffic to specific VLANs by using the **filter vlan** keyword. If a trunk port is being monitored, only traffic on the VLANs specified with this keyword is monitored. By default, all VLANs are monitored on a trunk port.
- You cannot mix source VLANs and filter VLANs within a single SPAN session.

Creating a Local SPAN Session

Beginning in privileged EXEC mode, follow these steps to create a SPAN session and specify the source (monitored) ports or VLANs and the destination (monitoring) ports:

	Command	Purpose
Step 1	configure terminal	Enter global configuration mode.
Step 2	no monitor session { <i>session_number</i> all local remote }	Remove any existing SPAN configuration for the session. For <i>session_number</i> , the range is 1 to 66. Specify all to remove all SPAN sessions, local to remove all local sessions, or remote to remove all remote SPAN sessions.

Command	Purpose
<p>Step 3 monitor session <i>session_number</i> source {interface <i>interface-id</i> vlan <i>vlan-id</i>} [, -] [both rx tx]</p>	<p>Specify the SPAN session and the source port (monitored port). For <i>session_number</i>, the range is 1 to 66. For <i>interface-id</i>, specify the source port or source VLAN to monitor.</p> <ul style="list-style-type: none"> For source <i>interface-id</i>, specify the source port to monitor. Valid interfaces include physical interfaces and port-channel logical interfaces (port-channel <i>port-channel-number</i>). Valid port-channel numbers are 1 to 6. For <i>vlan-id</i>, specify the source VLAN to monitor. The range is 1 to 4094 (excluding the RSPAN VLAN). <p>Note A single session can include multiple sources (ports or VLANs), defined in a series of commands, but you cannot combine source ports and source VLANs in one session.</p> <p>(Optional) [, -] Specify a series or range of interfaces. Enter a space before and after the comma; enter a space before and after the hyphen.</p> <p>(Optional) Specify the direction of traffic to monitor. If you do not specify a traffic direction, the SPAN monitors both sent and received traffic.</p> <ul style="list-style-type: none"> both—Monitor both received and sent traffic. This is the default. rx—Monitor received traffic. tx—Monitor sent traffic. <p>Note You can use the monitor session <i>session_number</i> source command multiple times to configure multiple source ports.</p>
<p>Step 4 monitor session <i>session_number</i> destination {interface <i>interface-id</i> [, -] [encapsulation {dot1q replicate}]}</p>	<p>Specify the SPAN session and the destination port (monitoring port). For <i>session_number</i>, specify the session number entered in step 3.</p> <p>Note For local SPAN, you must use the same session number for the source and destination interfaces.</p> <p>For <i>interface-id</i>, specify the destination port. The destination interface must be a physical port; it cannot be an EtherChannel, and it cannot be a VLAN.</p> <p>(Optional) [, -] Specify a series or range of interfaces. Enter a space before and after the comma; enter a space before and after the hyphen.</p> <p>(Optional) Enter encapsulation dot1q to specify that the destination interface uses the IEEE 802.1Q encapsulation method.</p> <p>(Optional) Enter encapsulation replicate to specify that the destination interface replicates the source interface encapsulation method. If not selected, the default is to send packets in native form (untagged).</p> <p>Note You can use monitor session <i>session_number</i> destination command multiple times to configure multiple destination ports.</p>

	Command	Purpose
Step 5	end	Return to privileged EXEC mode.
Step 6	show monitor [session <i>session_number</i>] show running-config	Verify the configuration.
Step 7	copy running-config startup-config	(Optional) Save the configuration in the configuration file.

To delete a SPAN session, use the **no monitor session *session_number*** global configuration command. To remove a source or destination port or VLAN from the SPAN session, use the **no monitor session *session_number* source {interface *interface-id* | vlan *vlan-id*}** global configuration command or the **no monitor session *session_number* destination interface *interface-id*** global configuration command. For destination interfaces, the encapsulation options are ignored with the **no** form of the command.

This example shows how to set up SPAN session 1 for monitoring source port traffic to a destination port. First, any existing SPAN configuration for session 1 is deleted, and then bidirectional traffic is mirrored from source Gigabit Ethernet port 1 to destination Gigabit Ethernet port 2, retaining the encapsulation method.

```
Switch(config)# no monitor session 1
Switch(config)# monitor session 1 source interface gigabitethernet0/1
Switch(config)# monitor session 1 destination interface gigabitethernet0/2
encapsulation replicate
Switch(config)# end
```

This example shows how to remove port 1 as a SPAN source for SPAN session 1:

```
Switch(config)# no monitor session 1 source interface gigabitethernet0/1
Switch(config)# end
```

This example shows how to disable received traffic monitoring on port 1, which was configured for bidirectional monitoring:

```
Switch(config)# no monitor session 1 source interface gigabitethernet0/1 rx
```

The monitoring of traffic received on port 1 is disabled, but traffic sent from this port continues to be monitored.

This example shows how to remove any existing configuration on SPAN session 2, configure SPAN session 2 to monitor received traffic on all ports belonging to VLANs 1 through 3, and send it to destination Gigabit Ethernet port 2. The configuration is then modified to also monitor all traffic on all ports belonging to VLAN 10.

```
Switch(config)# no monitor session 2
Switch(config)# monitor session 2 source vlan 1 - 3 rx
Switch(config)# monitor session 2 destination interface gigabitethernet0/2
Switch(config)# monitor session 2 source vlan 10
Switch(config)# end
```

Creating a Local SPAN Session and Configuring Incoming Traffic

Beginning in privileged EXEC mode, follow these steps to create a SPAN session, to specify the source ports or VLANs and the destination ports, and to enable incoming traffic on the destination port for a network security device (such as a Cisco IDS Sensor Appliance).

For details about the keywords not related to incoming traffic, see the [“Creating a Local SPAN Session” section on page 23-10](#).

	Command	Purpose
Step 1	configure terminal	Enter global configuration mode.
Step 2	no monitor session { <i>session_number</i> all local remote }	Remove any existing SPAN configuration for the session.
Step 3	monitor session <i>session_number</i> source { interface <i>interface-id</i> vlan <i>vlan-id</i> } [, -] [both rx tx]	Specify the SPAN session and the source port (monitored port).
Step 4	monitor session <i>session_number</i> destination { interface <i>interface-id</i> [, -] [encapsulation { dot1q replicate }] [ingress { dot1q vlan <i>vlan-id</i> untagged vlan <i>vlan-id</i> vlan <i>vlan-id</i> }]}	<p>Specify the SPAN session, the destination port, the packet encapsulation, and the ingress VLAN and encapsulation.</p> <p>For <i>session_number</i>, specify the session number entered in Step 3.</p> <p>For <i>interface-id</i>, specify the destination port. The destination interface must be a physical port; it cannot be an EtherChannel, and it cannot be a VLAN.</p> <p>(Optional) [, -] Specify a series or range of interfaces. Enter a space before and after the comma or hyphen.</p> <p>(Optional) Enter encapsulation dot1q to specify that the destination interface uses the IEEE 802.1Q encapsulation method.</p> <p>(Optional) Enter encapsulation replicate to specify that the destination interface replicates the source interface encapsulation method. If not selected, the default is to send packets in native form (untagged).</p> <p>Enter ingress with keywords to enable forwarding of incoming traffic on the destination port and to specify the encapsulation type:</p> <ul style="list-style-type: none"> • dot1q vlan <i>vlan-id</i>—Accept incoming packets with IEEE 802.1Q encapsulation with the specified VLAN as the default VLAN. • untagged vlan <i>vlan-id</i> or vlan <i>vlan-id</i>—Accept incoming packets with untagged encapsulation type with the specified VLAN as the default VLAN.
Step 5	end	Return to privileged EXEC mode.
Step 6	show monitor [session <i>session_number</i>] show running-config	Verify the configuration.
Step 7	copy running-config startup-config	(Optional) Save the configuration in the configuration file.

To delete a SPAN session, use the **no monitor session** *session_number* global configuration command. To remove a source or destination port or VLAN from the SPAN session, use the **no monitor session** *session_number* **source** {**interface** *interface-id* | **vlan** *vlan-id*} global configuration command or the **no monitor session** *session_number* **destination interface** *interface-id* global configuration command. For destination interfaces, the encapsulation and ingress options are ignored with the **no** form of the command.

This example shows how to remove any existing configuration on SPAN session 2, configure SPAN session 2 to monitor received traffic on Gigabit Ethernet source port 1, and send it to destination Gigabit Ethernet port 2 with the same egress encapsulation type as the source port, and to enable ingress forwarding with IEEE 802.1Q encapsulation and VLAN 6 as the default ingress VLAN.

```
Switch(config)# no monitor session 2
Switch(config)# monitor session 2 source gigabitethernet0/1 rx
Switch(config)# monitor session 2 destination interface gigabitethernet0/2 encapsulation
replicate ingress dot1q vlan 6
Switch(config)# end
```

Specifying VLANs to Filter

Beginning in privileged EXEC mode, follow these steps to limit SPAN source traffic to specific VLANs:

	Command	Purpose
Step 1	configure terminal	Enter global configuration mode.
Step 2	no monitor session { <i>session_number</i> all local remote }	Remove any existing SPAN configuration for the session. For <i>session_number</i> , the range is 1 to 66. Specify all to remove all SPAN sessions, local to remove all local sessions, or remote to remove all remote SPAN sessions.
Step 3	monitor session <i>session_number</i> source interface <i>interface-id</i>	Specify the characteristics of the source port (monitored port) and SPAN session. For <i>session_number</i> , the range is 1 to 66. For <i>interface-id</i> , specify the source port to monitor. The interface specified must already be configured as a trunk port.
Step 4	monitor session <i>session_number</i> filter vlan <i>vlan-id</i> [, -]	Limit the SPAN source traffic to specific VLANs. For <i>session_number</i> , enter the session number specified in Step 3. For <i>vlan-id</i> , the range is 1 to 4094. (Optional) Use a comma (,) to specify a series of VLANs, or use a hyphen (-) to specify a range of VLANs. Enter a space before and after the comma; enter a space before and after the hyphen.

	Command	Purpose
Step 5	monitor session <i>session_number</i> destination { interface <i>interface-id</i> [, -] [encapsulation { dot1q replicate }]}	Specify the SPAN session and the destination port (monitoring port). For <i>session_number</i> , specify the session number entered in Step 3. For <i>interface-id</i> , specify the destination port. The destination interface must be a physical port; it cannot be an EtherChannel, and it cannot be a VLAN. (Optional) [, -] Specify a series or range of interfaces. Enter a space before and after the comma; enter a space before and after the hyphen. (Optional) Enter encapsulation dot1q to specify that the destination interface uses the IEEE 802.1Q encapsulation method. (Optional) Enter encapsulation replicate to specify that the destination interface replicates the source interface encapsulation method. If not selected, the default is to send packets in native form (untagged).
Step 6	end	Return to privileged EXEC mode.
Step 7	show monitor [session <i>session_number</i>] show running-config	Verify the configuration.
Step 8	copy running-config startup-config	(Optional) Save the configuration in the configuration file.

To monitor all VLANs on the trunk port, use the **no monitor session** *session_number* **filter** global configuration command.

This example shows how to remove any existing configuration on SPAN session 2, configure SPAN session 2 to monitor traffic received on Gigabit Ethernet trunk port 2, and send traffic for only VLANs 1 through 5 and VLAN 9 to destination Gigabit Ethernet port 1.

```
Switch(config)# no monitor session 2
Switch(config)# monitor session 2 source interface gigabitethernet0/2 rx
Switch(config)# monitor session 2 filter vlan 1 - 5 , 9
Switch(config)# monitor session 2 destination interface gigabitethernet0/1
Switch(config)# end
```

Configuring RSPAN

These sections contain this configuration information:

- [RSPAN Configuration Guidelines, page 23-16](#)
- [Configuring a VLAN as an RSPAN VLAN, page 23-16](#)
- [Creating an RSPAN Source Session, page 23-17](#)
- [Creating an RSPAN Destination Session, page 23-19](#)
- [Creating an RSPAN Destination Session and Configuring Incoming Traffic, page 23-20](#)
- [Specifying VLANs to Filter, page 23-21](#)

RSPAN Configuration Guidelines

Follow these guidelines when configuring RSPAN:

- All the items in the [“SPAN Configuration Guidelines” section on page 23-10](#) apply to RSPAN.
- As RSPAN VLANs have special properties, you should reserve a few VLANs across your network for use as RSPAN VLANs; do not assign access ports to these VLANs.
- You can apply an output ACL to RSPAN traffic to selectively filter or monitor specific packets. Specify these ACLs on the RSPAN VLAN in the RSPAN source switches.
- For RSPAN configuration, you can distribute the source ports and the destination ports across multiple switches in your network.
- RSPAN does not support BPDU packet monitoring or other Layer 2 switch protocols.
- The RSPAN VLAN is configured only on trunk ports and not on access ports. To avoid unwanted traffic in RSPAN VLANs, make sure that the VLAN remote-span feature is supported in all the participating switches.
- Access ports (including voice VLAN ports) on the RSPAN VLAN are put in the inactive state.
- RSPAN VLANs are included as sources for port-based RSPAN sessions when source trunk ports have active RSPAN VLANs. RSPAN VLANs can also be sources in SPAN sessions. However, since the switch does not monitor spanned traffic, it does not support egress spanning of packets on any RSPAN VLAN identified as the destination of an RSPAN source session on the switch.
- You can configure any VLAN as an RSPAN VLAN as long as these conditions are met:
 - The same RSPAN VLAN is used for an RSPAN session in all the switches.
 - All participating switches support RSPAN.
- We recommend that you configure an RSPAN VLAN before you configure an RSPAN source or a destination session.
- If you enable VTP and VTP pruning, RSPAN traffic is pruned in the trunks to prevent the unwanted flooding of RSPAN traffic across the network for VLAN IDs that are lower than 1005.

Configuring a VLAN as an RSPAN VLAN

First create a new VLAN to be the RSPAN VLAN for the RSPAN session. You must create the RSPAN VLAN in all switches that will participate in RSPAN. If the RSPAN VLAN-ID is in the normal range (lower than 1005) and VTP is enabled in the network, you can create the RSPAN VLAN in one switch, and VTP propagates it to the other switches in the VTP domain. For extended-range VLANs (greater than 1005), you must configure RSPAN VLAN on both source and destination switches and any intermediate switches.

Use VTP pruning to get an efficient flow of RSPAN traffic, or manually delete the RSPAN VLAN from all trunks that do not need to carry the RSPAN traffic.

Beginning in privileged EXEC mode, follow these steps to create an RSPAN VLAN:

	Command	Purpose
Step 1	configure terminal	Enter global configuration mode.
Step 2	vlan <i>vlan-id</i>	Enter a VLAN ID to create a VLAN, or enter the VLAN ID of an existing VLAN, and enter VLAN configuration mode. The range is 2 to 1001 and 1006 to 4094. The RSPAN VLAN cannot be VLAN 1 (the default VLAN) or VLAN IDs 1002 through 1005 (reserved for Token Ring and FDDI VLANs).
Step 3	remote-span	Configure the VLAN as an RSPAN VLAN.
Step 4	end	Return to privileged EXEC mode.
Step 5	copy running-config startup-config	(Optional) Save the configuration in the configuration file.

To remove the remote SPAN characteristic from a VLAN and convert it back to a normal VLAN, use the **no remote-span** VLAN configuration command.

This example shows how to create RSPAN VLAN 901.

```
Switch(config)# vlan 901
Switch(config-vlan)# remote span
Switch(config-vlan)# end
```

Creating an RSPAN Source Session

Beginning in privileged EXEC mode, follow these steps to start an RSPAN source session and to specify the monitored source and the destination RSPAN VLAN:

	Command	Purpose
Step 1	configure terminal	Enter global configuration mode.
Step 2	no monitor session { <i>session_number</i> all local remote }	Remove any existing RSPAN configuration for the session. For <i>session_number</i> , the range is 1 to 66. Specify all to remove all RSPAN sessions, local to remove all local sessions, or remote to remove all remote SPAN sessions.

	Command	Purpose
Step 3	monitor session <i>session_number</i> source { interface <i>interface-id</i> vlan <i>vlan-id</i> } [, -] [both rx tx]	<p>Specify the RSPAN session and the source port (monitored port). For <i>session_number</i>, the range is 1 to 66.</p> <p>Enter a source port or source VLAN for the RSPAN session:</p> <ul style="list-style-type: none"> For <i>interface-id</i>, specify the source port to monitor. Valid interfaces include physical interfaces and port-channel logical interfaces (port-channel <i>port-channel-number</i>). Valid port-channel numbers are 1 to 6. For <i>vlan-id</i>, specify the source VLAN to monitor. The range is 1 to 4094 (excluding the RSPAN VLAN). <p>A single session can include multiple sources (ports or VLANs), defined in a series of commands, but you cannot combine source ports and source VLANs in one session.</p> <p>(Optional) [, -] Specify a series or range of interfaces. Enter a space before and after the comma; enter a space before and after the hyphen.</p> <p>(Optional) Specify the direction of traffic to monitor. If you do not specify a traffic direction, the source interface sends both sent and received traffic.</p> <ul style="list-style-type: none"> both—Monitor both received and sent traffic. rx—Monitor received traffic. tx—Monitor sent traffic.
Step 4	monitor session <i>session_number</i> destination remote vlan <i>vlan-id</i>	<p>Specify the RSPAN session and the destination RSPAN VLAN. For <i>session_number</i>, enter the number defined in Step 3. For <i>vlan-id</i>, specify the source RSPAN VLAN to monitor.</p>
Step 5	end	Return to privileged EXEC mode.
Step 6	show monitor [session <i>session_number</i>] show running-config	Verify the configuration.
Step 7	copy running-config startup-config	(Optional) Save the configuration in the configuration file.

To delete a SPAN session, use the **no monitor session** *session_number* global configuration command.

To remove a source port or VLAN from the SPAN session, use the **no monitor session** *session_number* **source** {**interface** *interface-id* | **vlan** *vlan-id*} global configuration command. To remove the RSPAN VLAN from the session, use the **no monitor session** *session_number* **destination remote vlan** *vlan-id*.

This example shows how to remove any existing RSPAN configuration for session 1, configure RSPAN session 1 to monitor multiple source interfaces, and configure the destination as RSPAN VLAN 901.

```
Switch(config)# no monitor session 1
Switch(config)# monitor session 1 source interface gigabitethernet0/1 tx
Switch(config)# monitor session 1 source interface gigabitethernet0/2 rx
Switch(config)# monitor session 1 source interface port-channel 2
Switch(config)# monitor session 1 destination remote vlan 901
Switch(config)# end
```

Creating an RSPAN Destination Session

You configure the RSPAN destination session on a different switch; that is, not the switch on which the source session was configured.

Beginning in privileged EXEC mode, follow these steps to define the RSPAN VLAN on that switch, to create an RSPAN destination session, and to specify the source RSPAN VLAN and the destination port:

	Command	Purpose
Step 1	configure terminal	Enter global configuration mode.
Step 2	vlan <i>vlan-id</i>	Enter the VLAN ID of the RSPAN VLAN created from the source switch, and enter VLAN configuration mode. If both switches are participating in VTP and the RSPAN VLAN ID is from 2 to 1005, Steps 2 through 4 are not required because the RSPAN VLAN ID is propagated through the VTP network.
Step 3	remote-span	Identify the VLAN as the RSPAN VLAN.
Step 4	exit	Return to global configuration mode.
Step 5	no monitor session { <i>session_number</i> all local remote }	Remove any existing RSPAN configuration for the session. For <i>session_number</i> , the range is 1 to 66. Specify all to remove all RSPAN sessions, local to remove all local sessions, or remote to remove all remote SPAN sessions.
Step 6	monitor session <i>session_number</i> source remote vlan <i>vlan-id</i>	Specify the RSPAN session and the source RSPAN VLAN. For <i>session_number</i> , the range is 1 to 66. For <i>vlan-id</i> , specify the source RSPAN VLAN to monitor.
Step 7	monitor session <i>session_number</i> destination interface <i>interface-id</i>	Specify the RSPAN session and the destination interface. For <i>session_number</i> , enter the number defined in Step 6. In an RSPAN destination session, you must use the same session number for the source RSPAN VLAN and the destination port. For <i>interface-id</i> , specify the destination interface. The destination interface must be a physical interface. Though visible in the command-line help string, encapsulation replicate is not supported for RSPAN. The original VLAN ID is overwritten by the RSPAN VLAN ID, and all packets appear on the destination port as untagged.
Step 8	end	Return to privileged EXEC mode.
Step 9	show monitor [session <i>session_number</i>] show running-config	Verify the configuration.
Step 10	copy running-config startup-config	(Optional) Save the configuration in the configuration file.

To delete a SPAN session, use the **no monitor session** *session_number* global configuration command. To remove a destination port from the SPAN session, use the **no monitor session** *session_number* **destination interface** *interface-id* global configuration command. To remove the RSPAN VLAN from the session, use the **no monitor session** *session_number* **source remote vlan** *vlan-id*.

This example shows how to configure VLAN 901 as the source remote VLAN and port 1 as the destination interface:

```
Switch(config)# monitor session 1 source remote vlan 901
Switch(config)# monitor session 1 destination interface gigabitethernet0/1
Switch(config)# end
```

Creating an RSPAN Destination Session and Configuring Incoming Traffic

Beginning in privileged EXEC mode, follow these steps to create an RSPAN destination session, to specify the source RSPAN VLAN and the destination port, and to enable incoming traffic on the destination port for a network security device (such as a Cisco IDS Sensor Appliance).

For details about the keywords not related to incoming traffic, see the [“Creating an RSPAN Destination Session” section on page 23-19](#). This procedure assumes that the RSPAN VLAN has already been configured.

	Command	Purpose
Step 1	configure terminal	Enter global configuration mode.
Step 2	no monitor session { <i>session_number</i> all local remote }	Remove any existing SPAN configuration for the session.
Step 3	monitor session <i>session_number</i> source remote vlan <i>vlan-id</i>	Specify the RSPAN session and the source RSPAN VLAN. For <i>session_number</i> , the range is 1 to 66. For <i>vlan-id</i> , specify the source RSPAN VLAN to monitor.
Step 4	monitor session <i>session_number</i> destination { interface <i>interface-id</i> [, -] [ingress { dot1q vlan <i>vlan-id</i> untagged vlan <i>vlan-id</i> vlan <i>vlan-id</i> }] }	Specify the SPAN session, the destination port, the packet encapsulation, and the incoming VLAN and encapsulation. For <i>session_number</i> , enter the number defined in Step 4. In an RSPAN destination session, you must use the same session number for the source RSPAN VLAN and the destination port. For <i>interface-id</i> , specify the destination interface. The destination interface must be a physical interface. Though visible in the command-line help string, encapsulation replicate is not supported for RSPAN. The original VLAN ID is overwritten by the RSPAN VLAN ID, and all packets appear on the destination port as untagged. (Optional) [, -] Specify a series or range of interfaces. Enter a space before and after the comma; enter a space before and after the hyphen. Enter ingress with additional keywords to enable forwarding of incoming traffic on the destination port and to specify the encapsulation type: <ul style="list-style-type: none"> dot1q vlan <i>vlan-id</i>—Forward incoming packets with IEEE 802.1Q encapsulation with the specified VLAN as the default VLAN. untagged vlan <i>vlan-id</i> or vlan <i>vlan-id</i>—Forward incoming packets with untagged encapsulation type with the specified VLAN as the default VLAN.

	Command	Purpose
Step 5	end	Return to privileged EXEC mode.
Step 6	show monitor [session <i>session_number</i>] show running-config	Verify the configuration.
Step 7	copy running-config startup-config	(Optional) Save the configuration in the configuration file.

To delete an RSPAN session, use the **no monitor session** *session_number* global configuration command. To remove a destination port from the RSPAN session, use the **no monitor session** *session_number* **destination interface** *interface-id* global configuration command. The ingress options are ignored with the **no** form of the command.

This example shows how to configure VLAN 901 as the source remote VLAN in RSPAN session 2, to configure Gigabit Ethernet source port 2 as the destination interface, and to enable forwarding of incoming traffic on the interface with VLAN 6 as the default receiving VLAN.

```
Switch(config)# monitor session 2 source remote vlan 901
Switch(config)# monitor session 2 destination interface gigabitethernet0/2 ingress vlan 6
Switch(config)# end
```

Specifying VLANs to Filter

Beginning in privileged EXEC mode, follow these steps to configure the RSPAN source session to limit RSPAN source traffic to specific VLANs:

	Command	Purpose
Step 1	configure terminal	Enter global configuration mode.
Step 2	no monitor session { <i>session_number</i> all local remote }	Remove any existing SPAN configuration for the session. For <i>session_number</i> , the range is 1 to 66. Specify all to remove all SPAN sessions, local to remove all local sessions, or remote to remove all remote SPAN sessions.
Step 3	monitor session <i>session_number</i> source interface <i>interface-id</i>	Specify the characteristics of the source port (monitored port) and SPAN session. For <i>session_number</i> , the range is 1 to 66. For <i>interface-id</i> , specify the source port to monitor. The interface specified must already be configured as a trunk port.
Step 4	monitor session <i>session_number</i> filter vlan <i>vlan-id</i> [, -]	Limit the SPAN source traffic to specific VLANs. For <i>session_number</i> , enter the session number specified in step 3. For <i>vlan-id</i> , the range is 1 to 4094. (Optional) Use a comma (,) to specify a series of VLANs or use a hyphen (-) to specify a range of VLANs. Enter a space before and after the comma; enter a space before and after the hyphen.

	Command	Purpose
Step 5	monitor session <i>session_number</i> destination remote vlan <i>vlan-id</i>	Specify the RSPAN session and the destination remote VLAN (RSPAN VLAN). For <i>session_number</i> , enter the session number specified in step 3. For <i>vlan-id</i> , specify the RSPAN VLAN to carry the monitored traffic to the destination port.
Step 6	end	Return to privileged EXEC mode.
Step 7	show monitor [<i>session session_number</i>] show running-config	Verify the configuration.
Step 8	copy running-config startup-config	(Optional) Save the configuration in the configuration file.

To monitor all VLANs on the trunk port, use the **no monitor session** *session_number* **filter vlan** global configuration command.

This example shows how to remove any existing configuration on RSPAN session 2, configure RSPAN session 2 to monitor traffic received on trunk port 2, and send traffic for only VLANs 1 through 5 and 9 to destination RSPAN VLAN 902.

```
Switch(config)# no monitor session 2
Switch(config)# monitor session 2 source interface gigabitethernet0/2 rx
Switch(config)# monitor session 2 filter vlan 1 - 5 , 9
Switch(config)# monitor session 2 destination remote vlan 902
Switch(config)# end
```

Displaying SPAN and RSPAN Status

To display the current SPAN or RSPAN configuration, use the **show monitor** user EXEC command. You can also use the **show running-config** privileged EXEC command to display configured SPAN or RSPAN sessions.



CHAPTER 24

Configuring RMON

This chapter describes how to configure Remote Network Monitoring (RMON) on the Catalyst 2960 switch.

RMON is a standard monitoring specification that defines a set of statistics and functions that can be exchanged between RMON-compliant console systems and network probes. RMON provides you with comprehensive network-fault diagnosis, planning, and performance-tuning information.



Note

For complete syntax and usage information for the commands used in this chapter, see the “System Management Commands” section in the *Cisco IOS Configuration Fundamentals Command Reference, Release 12.2* from the Cisco.com page under **Documentation > Cisco IOS Software > 12.2 Mainline > Command References**.

This chapter consists of these sections:

- [Understanding RMON, page 24-1](#)
- [Configuring RMON, page 24-2](#)
- [Displaying RMON Status, page 24-6](#)

Understanding RMON

RMON is an Internet Engineering Task Force (IETF) standard monitoring specification that allows various network agents and console systems to exchange network monitoring data. You can use the RMON feature with the Simple Network Management Protocol (SNMP) agent in the switch to monitor all the traffic flowing among switches on all connected LAN segments as shown in [Figure 24-1](#).

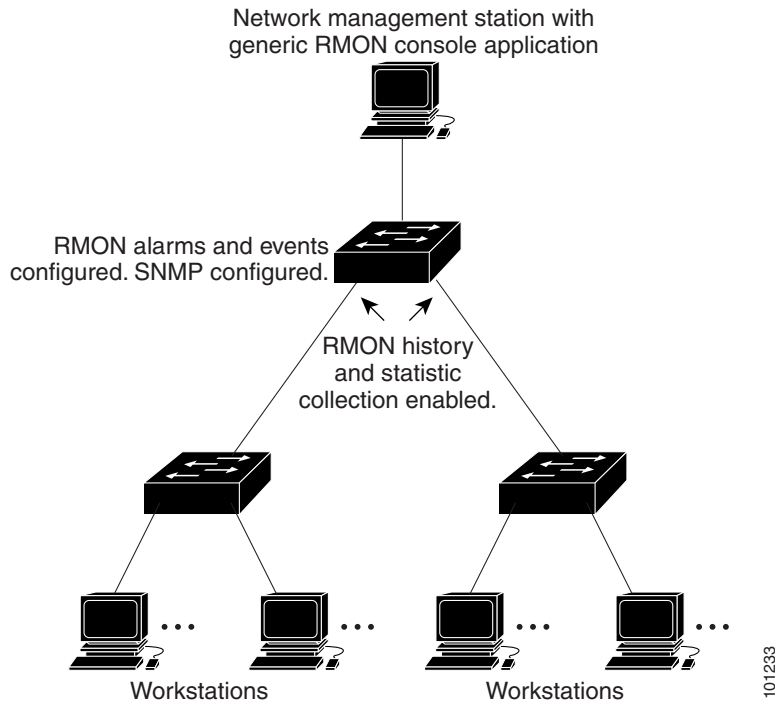
Figure 24-1 Remote Monitoring Example

The switch supports these RMON groups (defined in RFC 1757):

- Statistics (RMON group 1)—Collects Ethernet statistics (including Fast Ethernet and Gigabit Ethernet statistics, depending on the switch type and supported interfaces) on an interface.
- History (RMON group 2)—Collects a history group of statistics on Ethernet ports (including Fast Ethernet and Gigabit Ethernet statistics, depending on the switch type and supported interfaces) for a specified polling interval.
- Alarm (RMON group 3)—Monitors a specific management information base (MIB) object for a specified interval, triggers an alarm at a specified value (rising threshold), and resets the alarm at another value (falling threshold). Alarms can be used with events; the alarm triggers an event, which can generate a log entry or an SNMP trap.
- Event (RMON group 9)—Specifies the action to take when an event is triggered by an alarm. The action can be to generate a log entry or an SNMP trap.

Because switches supported by this software release use hardware counters for RMON data processing, the monitoring is more efficient, and little processing power is required.

Configuring RMON

These sections contain this configuration information:

- [Default RMON Configuration, page 24-3](#)
- [Configuring RMON Alarms and Events, page 24-3](#) (required)
- [Collecting Group History Statistics on an Interface, page 24-5](#) (optional)
- [Collecting Group Ethernet Statistics on an Interface, page 24-5](#) (optional)

Default RMON Configuration

RMON is disabled by default; no alarms or events are configured.

Configuring RMON Alarms and Events

You can configure your switch for RMON by using the command-line interface (CLI) or an SNMP-compatible network management station. We recommend that you use a generic RMON console application on the network management station (NMS) to take advantage of the RMON network management capabilities. You must also configure SNMP on the switch to access RMON MIB objects. For more information, see [Chapter 26, “Configuring SNMP.”](#)

Beginning in privileged EXEC mode, follow these steps to enable RMON alarms and events. This procedure is required.

	Command	Purpose
Step 1	configure terminal	Enter global configuration mode.
Step 2	rmon alarm <i>number variable interval</i> { absolute delta } rising-threshold <i>value</i> [<i>event-number</i>] falling-threshold <i>value</i> [<i>event-number</i>] [owner <i>string</i>]	Set an alarm on a MIB object. <ul style="list-style-type: none"> For <i>number</i>, specify the alarm number. The range is 1 to 65535. For <i>variable</i>, specify the MIB object to monitor. For <i>interval</i>, specify the time in seconds the alarm monitors the MIB variable. The range is 1 to 4294967295 seconds. Specify the absolute keyword to test each MIB variable directly. Specify the delta keyword to test the change between samples of a MIB variable. For <i>value</i>, specify a number at which the alarm is triggered and one for when the alarm is reset. The range for the rising threshold and falling threshold values is -2147483648 to 2147483647. (Optional) For <i>event-number</i>, specify the event number to trigger when the rising or falling threshold exceeds its limit. (Optional) For owner <i>string</i>, specify the owner of the alarm.

	Command	Purpose
Step 3	rmon event <i>number</i> [description <i>string</i>] [log] [owner <i>string</i>] [trap <i>community</i>]	Add an event in the RMON event table that is associated with an RMON event number. <ul style="list-style-type: none"> • For <i>number</i>, assign an event number. The range is 1 to 65535. • (Optional) For description <i>string</i>, specify a description of the event. • (Optional) Use the log keyword to generate an RMON log entry when the event is triggered. • (Optional) For owner <i>string</i>, specify the owner of this event. • (Optional) For trap <i>community</i>, enter the SNMP community string used for this trap.
Step 4	end	Return to privileged EXEC mode.
Step 5	show running-config	Verify your entries.
Step 6	copy running-config startup-config	(Optional) Save your entries in the configuration file.

To disable an alarm, use the **no rmon alarm** *number* global configuration command on each alarm you configured. You cannot disable at once all the alarms that you configured. To disable an event, use the **no rmon event** *number* global configuration command. To learn more about alarms and events and how they interact with each other, see RFC 1757.

You can set an alarm on any MIB object. The following example configures RMON alarm number 10 by using the **rmon alarm** command. The alarm monitors the MIB variable *ifEntry.20.1* once every 20 seconds until the alarm is disabled and checks the change in the variable's rise or fall. If the *ifEntry.20.1* value shows a MIB counter increase of 15 or more, such as from 100000 to 100015, the alarm is triggered. The alarm in turn triggers event number 1, which is configured with the **rmon event** command. Possible events can include a log entry or an SNMP trap. If the *ifEntry.20.1* value changes by 0, the alarm is reset and can be triggered again.

```
Switch(config)# rmon alarm 10 ifEntry.20.1 20 delta rising-threshold 15 1
falling-threshold 0 owner jjohnson
```

The following example creates RMON event number 1 by using the **rmon event** command. The event is defined as *High ifOutErrors* and generates a log entry when the event is triggered by the alarm. The user *jjones* owns the row that is created in the event table by this command. This example also generates an SNMP trap when the event is triggered.

```
Switch(config)# rmon event 1 log trap eventtrap description "High ifOutErrors" owner
jjones
```

Collecting Group History Statistics on an Interface

You must first configure RMON alarms and events to display collection information.

Beginning in privileged EXEC mode, follow these steps to collect group history statistics on an interface. This procedure is optional.

	Command	Purpose
Step 1	configure terminal	Enter global configuration mode.
Step 2	interface <i>interface-id</i>	Specify the interface on which to collect history, and enter interface configuration mode.
Step 3	rmon collection history <i>index</i> [buckets <i>bucket-number</i>] [interval <i>seconds</i>] [owner <i>ownername</i>]	Enable history collection for the specified number of buckets and time period. <ul style="list-style-type: none"> For <i>index</i>, identify the RMON group of statistics. The range is 1 to 65535. (Optional) For buckets <i>bucket-number</i>, specify the maximum number of buckets desired for the RMON collection history group of statistics. The range is 1 to 65535. The default is 50 buckets. (Optional) For interval <i>seconds</i>, specify the number of seconds in each polling cycle. The range is 1 to 3600. The default is 1800 seconds. (Optional) For owner <i>ownername</i>, enter the name of the owner of the RMON group of statistics.
Step 4	end	Return to privileged EXEC mode.
Step 5	show running-config	Verify your entries.
Step 6	show rmon history	Display the contents of the switch history table.
Step 7	copy running-config startup-config	(Optional) Save your entries in the configuration file.

To disable history collection, use the **no rmon collection history** *index* interface configuration command.

Collecting Group Ethernet Statistics on an Interface

Beginning in privileged EXEC mode, follow these steps to collect group Ethernet statistics on an interface. This procedure is optional.

	Command	Purpose
Step 1	configure terminal	Enter global configuration mode.
Step 2	interface <i>interface-id</i>	Specify the interface on which to collect statistics, and enter interface configuration mode.

	Command	Purpose
Step 3	rmon collection stats <i>index</i> [owner <i>ownername</i>]	Enable RMON statistic collection on the interface. <ul style="list-style-type: none"> For <i>index</i>, specify the RMON group of statistics. The range is from 1 to 65535. (Optional) For owner <i>ownername</i>, enter the name of the owner of the RMON group of statistics.
Step 4	end	Return to privileged EXEC mode.
Step 5	show running-config	Verify your entries.
Step 6	show rmon statistics	Display the contents of the switch statistics table.
Step 7	copy running-config startup-config	(Optional) Save your entries in the configuration file.

To disable the collection of group Ethernet statistics, use the **no rmon collection stats** *index* interface configuration command.

This example shows how to collect RMON statistics for the owner *root*:

```
Switch(config)# interface gigabitethernet0/1
Switch(config-if)# rmon collection stats 2 owner root
```

Displaying RMON Status

To display the RMON status, use one or more of the privileged EXEC commands in [Table 24-1](#):

Table 24-1 **Commands for Displaying RMON Status**

Command	Purpose
show rmon	Displays general RMON statistics.
show rmon alarms	Displays the RMON alarm table.
show rmon events	Displays the RMON event table.
show rmon history	Displays the RMON history table.
show rmon statistics	Displays the RMON statistics table.

For information about the fields in these displays, see the “System Management Commands” section in the *Cisco IOS Configuration Fundamentals Command Reference, Release 12.2* from the Cisco.com page under **Documentation > Cisco IOS Software > 12.2 Mainline > Command References**.



CHAPTER 25

Configuring System Message Logging

This chapter describes how to configure system message logging on the Catalyst 2960 switch.



Note

For complete syntax and usage information for the commands used in this chapter, see the *Cisco IOS Configuration Fundamentals Command Reference, Release 12.2* from the Cisco.com page under **Documentation > Cisco IOS Software > 12.2 Mainline > Command References**.

This chapter consists of these sections:

- [Understanding System Message Logging, page 25-1](#)
- [Configuring System Message Logging, page 25-2](#)
- [Displaying the Logging Configuration, page 25-13](#)



Caution

Logging messages to the console at a high rate can cause high CPU utilization and adversely affect how the switch operates.

Understanding System Message Logging

By default, a switch sends the output from system messages and **debug** privileged EXEC commands to a logging process. The logging process controls the distribution of logging messages to various destinations, such as the logging buffer, terminal lines, or a UNIX syslog server, depending on your configuration. The process also sends messages to the console.



Note

The syslog format is compatible with 4.3 BSD UNIX.

When the logging process is disabled, messages are sent only to the console. The messages are sent as they are generated, so message and debug output are interspersed with prompts or output from other commands. Messages appear on the console after the process that generated them has finished.

You can set the severity level of the messages to control the type of messages displayed on the consoles and each of the destinations. You can time-stamp log messages or set the syslog source address to enhance real-time debugging and management. For information on possible messages, see the system message guide for this release.

You can access logged system messages by using the switch command-line interface (CLI) or by saving them to a properly configured syslog server. The switch software saves syslog messages in an internal buffer.

You can remotely monitor system messages by viewing the logs on a syslog server or by accessing the switch through Telnet or through the console port.

Configuring System Message Logging

These sections contain this configuration information:

- [System Log Message Format, page 25-2](#)
- [Default System Message Logging Configuration, page 25-3](#)
- [Disabling Message Logging, page 25-4 \(optional\)](#)
- [Setting the Message Display Destination Device, page 25-5 \(optional\)](#)
- [Synchronizing Log Messages, page 25-6 \(optional\)](#)
- [Enabling and Disabling Time Stamps on Log Messages, page 25-7 \(optional\)](#)
- [Enabling and Disabling Sequence Numbers in Log Messages, page 25-8 \(optional\)](#)
- [Defining the Message Severity Level, page 25-8 \(optional\)](#)
- [Limiting Syslog Messages Sent to the History Table and to SNMP, page 25-10 \(optional\)](#)
- [Enabling the Configuration-Change Logger, page 25-10 \(optional\)](#)
- [Configuring UNIX Syslog Servers, page 25-12 \(optional\)](#)

System Log Message Format

System log messages can contain up to 80 characters and a percent sign (%), which follows the optional sequence number or time-stamp information, if configured. Messages appear in this format:

seq no:timestamp: %facility-severity-MNEMONIC:description

The part of the message preceding the percent sign depends on the setting of the **service sequence-numbers**, **service timestamps log datetime**, **service timestamps log datetime [localtime] [msec] [show-timezone]**, or **service timestamps log uptime** global configuration command.

Table 25-1 describes the elements of syslog messages.

Table 25-1 System Log Message Elements

Element	Description
<i>seq no:</i>	Stamps log messages with a sequence number only if the service sequence-numbers global configuration command is configured. For more information, see the “ Enabling and Disabling Sequence Numbers in Log Messages ” section on page 25-8.
<i>timestamp</i> formats: <i>mm/dd hh:mm:ss</i> or <i>hh:mm:ss</i> (short uptime) or <i>d h</i> (long uptime)	Date and time of the message or event. This information appears only if the service timestamps log [datetime log] global configuration command is configured. For more information, see the “ Enabling and Disabling Time Stamps on Log Messages ” section on page 25-7.
<i>facility</i>	The facility to which the message refers (for example, SNMP, SYS, and so forth). For a list of supported facilities, see Table 25-4 on page 25-13 .
<i>severity</i>	Single-digit code from 0 to 7 that is the severity of the message. For a description of the severity levels, see Table 25-3 on page 25-9 .
<i>MNEMONIC</i>	Text string that uniquely describes the message.
<i>description</i>	Text string containing detailed information about the event being reported.

This example shows a partial switch system message:

```
00:00:46: %LINK-3-UPDOWN: Interface Port-channell, changed state to up
00:00:47: %LINK-3-UPDOWN: Interface GigabitEthernet0/1, changed state to up
00:00:47: %LINK-3-UPDOWN: Interface GigabitEthernet0/2, changed state to up
00:00:48: %LINEPROTO-5-UPDOWN: Line protocol on Interface Vlan1, changed state to down
00:00:48: %LINEPROTO-5-UPDOWN: Line protocol on Interface GigabitEthernet0/1, changed
state to down 2
*Mar  1 18:46:11: %SYS-5-CONFIG_I: Configured from console by vty2 (10.34.195.36)
18:47:02: %SYS-5-CONFIG_I: Configured from console by vty2 (10.34.195.36)
*Mar  1 18:48:50.483 UTC: %SYS-5-CONFIG_I: Configured from console by vty2 (10.34.195.36)
```

Default System Message Logging Configuration

Table 25-2 shows the default system message logging configuration.

Table 25-2 Default System Message Logging Configuration

Feature	Default Setting
System message logging to the console	Enabled.
Console severity	Debugging (and numerically lower levels; see Table 25-3 on page 25-9).
Logging file configuration	No filename specified.
Logging buffer size	4096 bytes.
Logging history size	1 message.

Table 25-2 Default System Message Logging Configuration (continued)

Feature	Default Setting
Time stamps	Disabled.
Synchronous logging	Disabled.
Logging server	Disabled.
Syslog server IP address	None configured.
Configuration change logger	Disabled
Server facility	Local7 (see Table 25-4 on page 25-13).
Server severity	Informational (and numerically lower levels; see Table 25-3 on page 25-9).

Disabling Message Logging

Message logging is enabled by default. It must be enabled to send messages to any destination other than the console. When enabled, log messages are sent to a logging process, which logs messages to designated locations asynchronously to the processes that generated the messages.

Beginning in privileged EXEC mode, follow these steps to disable message logging. This procedure is optional.

	Command	Purpose
Step 1	configure terminal	Enter global configuration mode.
Step 2	no logging console	Disable message logging.
Step 3	end	Return to privileged EXEC mode.
Step 4	show running-config or show logging	Verify your entries.
Step 5	copy running-config startup-config	(Optional) Save your entries in the configuration file.

Disabling the logging process can slow down the switch because a process must wait until the messages are written to the console before continuing. When the logging process is disabled, messages appear on the console as soon as they are produced, often appearing in the middle of command output.

The **logging synchronous** global configuration command also affects the display of messages to the console. When this command is enabled, messages appear only after you press Return. For more information, see the “[Synchronizing Log Messages](#)” section on page 25-6.

To re-enable message logging after it has been disabled, use the **logging on** global configuration command.

Setting the Message Display Destination Device

If message logging is enabled, you can send messages to specific locations in addition to the console. Beginning in privileged EXEC mode, use one or more of the following commands to specify the locations that receive messages. This procedure is optional.

	Command	Purpose
Step 1	configure terminal	Enter global configuration mode.
Step 2	logging buffered [<i>size</i>]	<p>Log messages to an internal buffer on the switch. The range is 4096 to 2147483647 bytes. The default buffer size is 4096 bytes.</p> <p>If the switch fails, the log file is lost unless you had previously saved it to flash memory. See Step 4.</p> <p>Note Do not make the buffer size too large because the switch could run out of memory for other tasks. Use the show memory privileged EXEC command to view the free processor memory on the switch. However, this value is the maximum available, and the buffer size should <i>not</i> be set to this amount.</p>
Step 3	logging host	<p>Log messages to a UNIX syslog server host.</p> <p>For <i>host</i>, specify the name or IP address of the host to be used as the syslog server.</p> <p>To build a list of syslog servers that receive logging messages, enter this command more than once.</p> <p>For complete syslog server configuration steps, see the “Configuring UNIX Syslog Servers” section on page 25-12.</p>
Step 4	logging file flash: <i>filename</i> [<i>max-file-size</i> [<i>min-file-size</i>]] [<i>severity-level-number</i> <i>type</i>]	<p>Store log messages in a file in flash memory.</p> <ul style="list-style-type: none"> For <i>filename</i>, enter the log message filename. (Optional) For <i>max-file-size</i>, specify the maximum logging file size. The range is 4096 to 2147483647. The default is 4096 bytes. (Optional) For <i>min-file-size</i>, specify the minimum logging file size. The range is 1024 to 2147483647. The default is 2048 bytes. (Optional) For <i>severity-level-number</i> <i>type</i>, specify either the logging severity level or the logging type. The severity range is 0 to 7. For a list of logging type keywords, see Table 25-3 on page 25-9. By default, the log file receives debugging messages and numerically lower levels.
Step 5	end	Return to privileged EXEC mode.
Step 6	terminal monitor	<p>Log messages to a nonconsole terminal during the current session.</p> <p>Terminal parameter-setting commands are set locally and do not remain in effect after the session has ended. You must perform this step for each session to see the debugging messages.</p>
Step 7	show running-config	Verify your entries.
Step 8	copy running-config startup-config	(Optional) Save your entries in the configuration file.

The **logging buffered** global configuration command copies logging messages to an internal buffer. The buffer is circular, so newer messages overwrite older messages after the buffer is full. To display the messages that are logged in the buffer, use the **show logging** privileged EXEC command. The first message displayed is the oldest message in the buffer. To clear the contents of the buffer, use the **clear logging** privileged EXEC command.

To disable logging to the console, use the **no logging console** global configuration command. To disable logging to a file, use the **no logging file** [*severity-level-number* | *type*] global configuration command.

Synchronizing Log Messages

You can synchronize unsolicited messages and **debug** privileged EXEC command output with solicited device output and prompts for a specific console port line or virtual terminal line. You can identify the types of messages to be output asynchronously based on the level of severity. You can also configure the maximum number of buffers for storing asynchronous messages for the terminal after which messages are dropped.

When synchronous logging of unsolicited messages and **debug** command output is enabled, unsolicited device output appears on the console or printed after solicited device output appears or is printed. Unsolicited messages and **debug** command output appears on the console after the prompt for user input is returned. Therefore, unsolicited messages and **debug** command output are not interspersed with solicited device output and prompts. After the unsolicited messages appear, the console again displays the user prompt.

Beginning in privileged EXEC mode, follow these steps to configure synchronous logging. This procedure is optional.

	Command	Purpose
Step 1	configure terminal	Enter global configuration mode.
Step 2	line [console vty] <i>line-number</i> [<i>ending-line-number</i>]	Specify the line to be configured for synchronous logging of messages. <ul style="list-style-type: none"> Use the console keyword for configurations that occur through the switch console port. Use the line vty line-number command to specify which vty lines are to have synchronous logging enabled. You use a vty connection for configurations that occur through a Telnet session. The range of line numbers is from 0 to 15. <p>You can change the setting of all 16 vty lines at once by entering:</p> <p>line vty 0 15</p> <p>Or you can change the setting of the single vty line being used for your current connection. For example, to change the setting for vty line 2, enter:</p> <p>line vty 2</p> <p>When you enter this command, the mode changes to line configuration.</p>

	Command	Purpose
Step 3	logging synchronous [level [<i>severity-level</i> all] limit <i>number-of-buffers</i>]	Enable synchronous logging of messages. <ul style="list-style-type: none"> (Optional) For level <i>severity-level</i>, specify the message severity level. Messages with a severity level equal to or higher than this value are printed asynchronously. Low numbers mean greater severity and high numbers mean lesser severity. The default is 2. (Optional) Specifying level all means that all messages are printed asynchronously regardless of the severity level. (Optional) For limit <i>number-of-buffers</i>, specify the number of buffers to be queued for the terminal after which new messages are dropped. The range is 0 to 2147483647. The default is 20.
Step 4	end	Return to privileged EXEC mode.
Step 5	show running-config	Verify your entries.
Step 6	copy running-config startup-config	(Optional) Save your entries in the configuration file.

To disable synchronization of unsolicited messages and debug output, use the **no logging synchronous** [**level** *severity-level* | **all**] [**limit** *number-of-buffers*] line configuration command.

Enabling and Disabling Time Stamps on Log Messages

By default, log messages are not time-stamped.

Beginning in privileged EXEC mode, follow these steps to enable time-stamping of log messages. This procedure is optional.

	Command	Purpose
Step 1	configure terminal	Enter global configuration mode.
Step 2	service timestamps log uptime or service timestamps log datetime [msec] [localtime] [show-timezone]	Enable log time stamps. The first command enables time stamps on log messages, showing the time since the system was rebooted. The second command enables time stamps on log messages. Depending on the options selected, the time stamp can include the date, time in milliseconds relative to the local time-zone, and the time zone name.
Step 3	end	Return to privileged EXEC mode.
Step 4	show running-config	Verify your entries.
Step 5	copy running-config startup-config	(Optional) Save your entries in the configuration file.

To disable time stamps for both debug and log messages, use the **no service timestamps** global configuration command.

This example shows part of a logging display with the **service timestamps log datetime** global configuration command enabled:

```
*Mar 1 18:46:11: %SYS-5-CONFIG_I: Configured from console by vty2 (10.34.195.36)
```

This example shows part of a logging display with the **service timestamps log uptime** global configuration command enabled:

```
00:00:46: %LINK-3-UPDOWN: Interface Port-channel1, changed state to up
```

Enabling and Disabling Sequence Numbers in Log Messages

Because there is a chance that more than one log message can have the same time stamp, you can display messages with sequence numbers so that you can unambiguously see a single message. By default, sequence numbers in log messages are not displayed.

Beginning in privileged EXEC mode, follow these steps to enable sequence numbers in log messages. This procedure is optional.

	Command	Purpose
Step 1	configure terminal	Enter global configuration mode.
Step 2	service sequence-numbers	Enable sequence numbers.
Step 3	end	Return to privileged EXEC mode.
Step 4	show running-config	Verify your entries.
Step 5	copy running-config startup-config	(Optional) Save your entries in the configuration file.

To disable sequence numbers, use the **no service sequence-numbers** global configuration command.

This example shows part of a logging display with sequence numbers enabled:

```
000019: %SYS-5-CONFIG_I: Configured from console by vty2 (10.34.195.36)
```

Defining the Message Severity Level

You can limit messages displayed to the selected device by specifying the severity level of the message, which are described in [Table 25-3](#).

Beginning in privileged EXEC mode, follow these steps to define the message severity level. This procedure is optional.

	Command	Purpose
Step 1	configure terminal	Enter global configuration mode.
Step 2	logging console <i>level</i>	Limit messages logged to the console. By default, the console receives debugging messages and numerically lower levels (see Table 25-3 on page 25-9).
Step 3	logging monitor <i>level</i>	Limit messages logged to the terminal lines. By default, the terminal receives debugging messages and numerically lower levels (see Table 25-3 on page 25-9).

	Command	Purpose
Step 4	logging trap <i>level</i>	Limit messages logged to the syslog servers. By default, syslog servers receive informational messages and numerically lower levels (see Table 25-3 on page 25-9). For complete syslog server configuration steps, see the “ Configuring UNIX Syslog Servers ” section on page 25-12.
Step 5	end	Return to privileged EXEC mode.
Step 6	show running-config or show logging	Verify your entries.
Step 7	copy running-config startup-config	(Optional) Save your entries in the configuration file.

**Note**

Specifying a *level* causes messages at that level and numerically lower levels to appear at the destination.

To disable logging to the console, use the **no logging console** global configuration command. To disable logging to a terminal other than the console, use the **no logging monitor** global configuration command. To disable logging to syslog servers, use the **no logging trap** global configuration command.

[Table 25-3](#) describes the *level* keywords. It also lists the corresponding UNIX syslog definitions from the most severe level to the least severe level.

Table 25-3 Message Logging Level Keywords

Level Keyword	Level	Description	Syslog Definition
emergencies	0	System unstable	LOG_EMERG
alerts	1	Immediate action needed	LOG_ALERT
critical	2	Critical conditions	LOG_CRIT
errors	3	Error conditions	LOG_ERR
warnings	4	Warning conditions	LOG_WARNING
notifications	5	Normal but significant condition	LOG_NOTICE
informational	6	Informational messages only	LOG_INFO
debugging	7	Debugging messages	LOG_DEBUG

The software generates four other categories of messages:

- Error messages about software or hardware malfunctions, displayed at levels **warnings** through **emergencies**. These types of messages mean that the functionality of the switch is affected. For information on how to recover from these malfunctions, see the system message guide for this release.
- Output from the **debug** commands, displayed at the **debugging** level. Debug commands are typically used only by the Technical Assistance Center.
- Interface up or down transitions and system restart messages, displayed at the **notifications** level. This message is only for information; switch functionality is not affected.

Limiting Syslog Messages Sent to the History Table and to SNMP

If you enabled syslog message traps to be sent to an SNMP network management station by using the **snmp-server enable trap** global configuration command, you can change the level of messages sent and stored in the switch history table. You also can change the number of messages that are stored in the history table.

Messages are stored in the history table because SNMP traps are not guaranteed to reach their destination. By default, one message of the level **warning** and numerically lower levels (see [Table 25-3 on page 25-9](#)) are stored in the history table even if syslog traps are not enabled.

Beginning in privileged EXEC mode, follow these steps to change the level and history table size defaults. This procedure is optional.

	Command	Purpose
Step 1	configure terminal	Enter global configuration mode.
Step 2	logging history level¹	Change the default level of syslog messages stored in the history file and sent to the SNMP server. See Table 25-3 on page 25-9 for a list of <i>level</i> keywords. By default, warnings , errors , critical , alerts , and emergencies messages are sent.
Step 3	logging history size number	Specify the number of syslog messages that can be stored in the history table. The default is to store one message. The range is 0 to 500 messages.
Step 4	end	Return to privileged EXEC mode.
Step 5	show running-config	Verify your entries.
Step 6	copy running-config startup-config	(Optional) Save your entries in the configuration file.

1. [Table 25-3](#) lists the level keywords and severity level. For SNMP usage, the severity level values increase by 1. For example, *emergencies* equal 1, not 0, and *critical* equals 3, not 2.

When the history table is full (it contains the maximum number of message entries specified with the **logging history size** global configuration command), the oldest message entry is deleted from the table to allow the new message entry to be stored.

To return the logging of syslog messages to the default level, use the **no logging history** global configuration command. To return the number of messages in the history table to the default value, use the **no logging history size** global configuration command.

Enabling the Configuration-Change Logger

You can enable a configuration logger to keep track of configuration changes made with the command-line interface (CLI). When you enter the **logging enable** configuration-change logger configuration command, the log records the session, the user, and the command that was entered to change the configuration. You can configure the size of the configuration log from 1 to 1000 entries (the default is 100). You can clear the log at any time by entering the **no logging enable** command followed by the **logging enable** command to disable and reenabling logging.

Use the **show archive log config** { **all** | *number* [*end-number*] | **user** *username* [**session** *number*] *number* [*end-number*] | **statistics** } [**provisioning**] privileged EXEC command to display the complete configuration log or the log for specified parameters.

The default is that configuration logging is disabled.

For information about the commands, see the *Cisco IOS Configuration Fundamentals and Network Management Command Reference, Release 12.3 T* at this URL:

http://www.cisco.com/en/US/products/sw/iosswrel/ps5207/products_command_reference_chapter09186a00801a8086.html#wp1114989

Beginning in privileged EXEC mode, follow these steps to enable configuration logging:

	Command	Purpose
Step 1	configure terminal	Enter global configuration mode.
Step 2	archive	Enter archive configuration mode.
Step 3	log config	Enter configuration-change logger configuration mode.
Step 4	logging enable	Enable configuration change logging.
Step 5	logging size <i>entries</i>	(Optional) Configure the number of entries retained in the configuration log. The range is from 1 to 1000. The default is 100. Note When the configuration log is full, the oldest log entry is removed each time a new entry is entered.
Step 6	end	Return to privileged EXEC mode.
Step 7	show archive log config	Verify your entries by viewing the configuration log.

This example shows how to enable the configuration-change logger and to set the number of entries in the log to 500.

```
Switch(config)# archive
Switch(config-archive)# log config
Switch(config-archive-log-cfg)# logging enable
Switch(config-archive-log-cfg)# logging size 500
Switch(config-archive-log-cfg)# end
```

This is an example of output for the configuration log:

```
Switch# show archive log config all
idx  sess  user@line  Logged command
 38  11  unknown user@vty3  |no aaa authorization config-commands
 39  12  unknown user@vty3  |no aaa authorization network default group radius
 40  12  unknown user@vty3  |no aaa accounting dot1x default start-stop group
radius
 41  13  unknown user@vty3  |no aaa accounting system default
 42  14  temi@vty4  |interface GigabitEthernet4/0/1
 43  14  temi@vty4  | switchport mode trunk
 44  14  temi@vty4  | exit
 45  16  temi@vty5  |interface FastEthernet5/0/1
 46  16  temi@vty5  | switchport mode trunk
 47  16  temi@vty5  | exit
```

Configuring UNIX Syslog Servers

The next sections describe how to configure the UNIX server syslog daemon and how to define the UNIX system logging facility.

Logging Messages to a UNIX Syslog Daemon

Before you can send system log messages to a UNIX syslog server, you must configure the syslog daemon on a UNIX server. This procedure is optional.

Log in as root, and perform these steps:



Note

Some recent versions of UNIX syslog daemons no longer accept by default syslog packets from the network. If this is the case with your system, use the UNIX **man syslogd** command to decide what options must be added to or removed from the syslog command line to enable logging of remote syslog messages.

Step 1 Add a line such as the following to the file `/etc/syslog.conf`:

```
local7.debug /usr/adm/logs/cisco.log
```

The **local7** keyword specifies the logging facility to be used; see [Table 25-4 on page 25-13](#) for information on the facilities. The **debug** keyword specifies the syslog level; see [Table 25-3 on page 25-9](#) for information on the severity levels. The syslog daemon sends messages at this level or at a more severe level to the file specified in the next field. The file must already exist, and the syslog daemon must have permission to write to it.

Step 2 Create the log file by entering these commands at the UNIX shell prompt:

```
$ touch /var/log/cisco.log
$ chmod 666 /var/log/cisco.log
```

Step 3 Make sure the syslog daemon reads the new changes:

```
$ kill -HUP `cat /etc/syslog.pid`
```

For more information, see the **man syslog.conf** and **man syslogd** commands on your UNIX system.

Configuring the UNIX System Logging Facility

When sending system log messages to an external device, you can cause the switch to identify its messages as originating from any of the UNIX syslog facilities.

Beginning in privileged EXEC mode, follow these steps to configure UNIX system facility message logging. This procedure is optional.

	Command	Purpose
Step 1	configure terminal	Enter global configuration mode.
Step 2	logging host	Log messages to a UNIX syslog server host by entering its IP address. To build a list of syslog servers that receive logging messages, enter this command more than once.

	Command	Purpose
Step 3	logging trap <i>level</i>	Limit messages logged to the syslog servers. By default, syslog servers receive informational messages and lower. See Table 25-3 on page 25-9 for <i>level</i> keywords.
Step 4	logging facility <i>facility-type</i>	Configure the syslog facility. See Table 25-4 on page 25-13 for <i>facility-type</i> keywords. The default is local7 .
Step 5	end	Return to privileged EXEC mode.
Step 6	show running-config	Verify your entries.
Step 7	copy running-config startup-config	(Optional) Save your entries in the configuration file.

To remove a syslog server, use the **no logging host** global configuration command, and specify the syslog server IP address. To disable logging to syslog servers, enter the **no logging trap** global configuration command.

[Table 25-4](#) lists the UNIX system facilities supported by the software. For more information about these facilities, consult the operator's manual for your UNIX operating system.

Table 25-4 Logging Facility-Type Keywords

Facility Type Keyword	Description
auth	Authorization system
cron	Cron facility
daemon	System daemon
kern	Kernel
local0-7	Locally defined messages
lpr	Line printer system
mail	Mail system
news	USENET news
sys9-14	System use
syslog	System log
user	User process
uucp	UNIX-to-UNIX copy system

Displaying the Logging Configuration

To display the logging configuration and the contents of the log buffer, use the **show logging** privileged EXEC command. For information about the fields in this display, see the *Cisco IOS Configuration Fundamentals Command Reference, Release 12.2* from the Cisco.com page under **Documentation > Cisco IOS Software > 12.2 Mainline > Command References**.



CHAPTER 26

Configuring SNMP

This chapter describes how to configure the Simple Network Management Protocol (SNMP) on the Catalyst 2960 switch.



Note

For complete syntax and usage information for the commands used in this chapter, see the command reference for this release and the *Cisco IOS Configuration Fundamentals Command Reference, Release 12.2* from the Cisco.com page under **Documentation > Cisco IOS Software > 12.2 Mainline > Command References**.

This chapter consists of these sections:

- [Understanding SNMP, page 26-1](#)
- [Configuring SNMP, page 26-6](#)
- [Displaying SNMP Status, page 26-18](#)

Understanding SNMP

SNMP is an application-layer protocol that provides a message format for communication between managers and agents. The SNMP system consists of an SNMP manager, an SNMP agent, and a MIB. The SNMP manager can be part of a network management system (NMS) such as CiscoWorks. The agent and MIB reside on the switch. To configure SNMP on the switch, you define the relationship between the manager and the agent.

The SNMP agent contains MIB variables whose values the SNMP manager can request or change. A manager can get a value from an agent or store a value into the agent. The agent gathers data from the MIB, the repository for information about device parameters and network data. The agent can also respond to a manager's requests to get or set data.

An agent can send unsolicited traps to the manager. Traps are messages alerting the SNMP manager to a condition on the network. Traps can mean improper user authentication, restarts, link status (up or down), MAC address tracking, closing of a TCP connection, loss of connection to a neighbor, or other significant events.

These sections contain this conceptual information:

- [SNMP Versions, page 26-2](#)
- [SNMP Manager Functions, page 26-3](#)
- [SNMP Agent Functions, page 26-4](#)

- [SNMP Community Strings](#), page 26-4
- [Using SNMP to Access MIB Variables](#), page 26-4
- [SNMP Notifications](#), page 26-5
- [SNMP ifIndex MIB Object Values](#), page 26-6

SNMP Versions

This software release supports these SNMP versions:

- **SNMPv1**—The Simple Network Management Protocol, a Full Internet Standard, defined in RFC 1157.
- **SNMPv2C** replaces the Party-based Administrative and Security Framework of SNMPv2Classic with the community-string-based Administrative Framework of SNMPv2C while retaining the bulk retrieval and improved error handling of SNMPv2Classic. It has these features:
 - **SNMPv2**—Version 2 of the Simple Network Management Protocol, a Draft Internet Standard, defined in RFCs 1902 through 1907.
 - **SNMPv2C**—The community-string-based Administrative Framework for SNMPv2, an Experimental Internet Protocol defined in RFC 1901.
- **SNMPv3**—Version 3 of the SNMP is an interoperable standards-based protocol defined in RFCs 2273 to 2275. SNMPv3 provides secure access to devices by authenticating and encrypting packets over the network and includes these security features:
 - **Message integrity**—ensuring that a packet was not tampered with in transit
 - **Authentication**—determining that the message is from a valid source
 - **Encryption**—mixing the contents of a package to prevent it from being read by an unauthorized source.



Note To select encryption, enter the **priv** keyword. This keyword is available only when the cryptographic (encrypted) software image is installed.

Both SNMPv1 and SNMPv2C use a community-based form of security. The community of managers able to access the agent's MIB is defined by an IP address access control list and password.

SNMPv2C includes a bulk retrieval mechanism and more detailed error message reporting to management stations. The bulk retrieval mechanism retrieves tables and large quantities of information, minimizing the number of round-trips required. The SNMPv2C improved error-handling includes expanded error codes that distinguish different kinds of error conditions; these conditions are reported through a single error code in SNMPv1. Error return codes in SNMPv2C report the error type.

SNMPv3 provides for both security models and security levels. A security model is an authentication strategy set up for a user and the group within which the user resides. A security level is the permitted level of security within a security model. A combination of the security level and the security model determine which security mechanism is used when handling an SNMP packet. Available security models are SNMPv1, SNMPv2C, and SNMPv3.

Table 26-1 identifies the characteristics of the different combinations of security models and levels.

Table 26-1 *SNMP Security Models and Levels*

Model	Level	Authentication	Encryption	Result
SNMPv1	noAuthNoPriv	Community string	No	Uses a community string match for authentication.
SNMPv2C	noAuthNoPriv	Community string	No	Uses a community string match for authentication.
SNMPv3	noAuthNoPriv	Username	No	Uses a username match for authentication.
SNMPv3	authNoPriv	MD5 or SHA	No	Provides authentication based on the HMAC-MD5 or HMAC-SHA algorithms.
SNMPv3	authPriv (requires the cryptographic software image)	MD5 or SHA	DES	Provides authentication based on the HMAC-MD5 or HMAC-SHA algorithms. Provides DES 56-bit encryption in addition to authentication based on the CBC-DES (DES-56) standard.

You must configure the SNMP agent to use the SNMP version supported by the management station. Because an agent can communicate with multiple managers, you can configure the software to support communications using SNMPv1, SNMPv2C, or SNMPv3.

SNMP Manager Functions

The SNMP manager uses information in the MIB to perform the operations described in Table 26-2.

Table 26-2 *SNMP Operations*

Operation	Description
get-request	Retrieves a value from a specific variable.
get-next-request	Retrieves a value from a variable within a table. ¹
get-bulk-request ²	Retrieves large blocks of data, such as multiple rows in a table, that would otherwise require the transmission of many small blocks of data.
get-response	Replies to a get-request, get-next-request, and set-request sent by an NMS.
set-request	Stores a value in a specific variable.
trap	An unsolicited message sent by an SNMP agent to an SNMP manager when some event has occurred.

1. With this operation, an SNMP manager does not need to know the exact variable name. A sequential search is performed to find the needed variable from within a table.
2. The **get-bulk** command only works with SNMPv2 or later.

SNMP Agent Functions

The SNMP agent responds to SNMP manager requests as follows:

- Get a MIB variable—The SNMP agent begins this function in response to a request from the NMS. The agent retrieves the value of the requested MIB variable and responds to the NMS with that value.
- Set a MIB variable—The SNMP agent begins this function in response to a message from the NMS. The SNMP agent changes the value of the MIB variable to the value requested by the NMS.

The SNMP agent also sends unsolicited trap messages to notify an NMS that a significant event has occurred on the agent. Examples of trap conditions include, but are not limited to, when a port or module goes up or down, when spanning-tree topology changes occur, and when authentication failures occur.

SNMP Community Strings

SNMP community strings authenticate access to MIB objects and function as embedded passwords. In order for the NMS to access the switch, the community string definitions on the NMS must match at least one of the three community string definitions on the switch.

A community string can have one of these attributes:

- Read-only (RO)—Gives read access to authorized management stations to all objects in the MIB except the community strings, but does not allow write access
- Read-write (RW)—Gives read and write access to authorized management stations to all objects in the MIB, but does not allow access to the community strings
- When a cluster is created, the command switch manages the exchange of messages among member switches and the SNMP application. The Network Assistant software appends the member switch number (*@esN*, where *N* is the switch number) to the first configured RW and RO community strings on the command switch and propagates them to the member switches. For more information, see [Chapter 5, “Clustering Switches”](#) and see *Getting Started with Cisco Network Assistant*, available on Cisco.com.

Using SNMP to Access MIB Variables

An example of an NMS is the CiscoWorks network management software. CiscoWorks 2000 software uses the switch MIB variables to set device variables and to poll devices on the network for specific information. The results of a poll can be displayed as a graph and analyzed to troubleshoot internetworking problems, increase network performance, verify the configuration of devices, monitor traffic loads, and more.

As shown in [Figure 26-1](#), the SNMP agent gathers data from the MIB. The agent can send traps, or notification of certain events, to the SNMP manager, which receives and processes the traps. Traps alert the SNMP manager to a condition on the network such as improper user authentication, restarts, link status (up or down), MAC address tracking, and so forth. The SNMP agent also responds to MIB-related queries sent by the SNMP manager in *get-request*, *get-next-request*, and *set-request* format.

Figure 26-1 SNMP Network

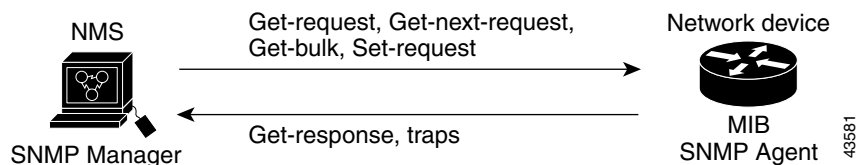

For information on supported MIBs and how to access them, see [Appendix A, “Supported MIBs.”](#)

SNMP Notifications

SNMP allows the switch to send notifications to SNMP managers when particular events occur. SNMP notifications can be sent as traps or inform requests. In command syntax, unless there is an option in the command to select either traps or informs, the keyword *traps* refers to either traps or informs, or both. Use the **snmp-server host** command to specify whether to send SNMP notifications as traps or informs.



Note

SNMPv1 does not support informs.

Traps are unreliable because the receiver does not send an acknowledgment when it receives a trap, and the sender cannot determine if the trap was received. When an SNMP manager receives an inform request, it acknowledges the message with an SNMP response protocol data unit (PDU). If the sender does not receive a response, the inform request can be sent again. Because they can be re-sent, informs are more likely than traps to reach their intended destination.

The characteristics that make informs more reliable than traps also consume more resources in the switch and in the network. Unlike a trap, which is discarded as soon as it is sent, an inform request is held in memory until a response is received or the request times out. Traps are sent only once, but an inform might be re-sent or retried several times. The retries increase traffic and contribute to a higher overhead on the network. Therefore, traps and informs require a trade-off between reliability and resources. If it is important that the SNMP manager receive every notification, use inform requests. If traffic on the network or memory in the switch is a concern and notification is not required, use traps.

SNMP ifIndex MIB Object Values

In an NMS, the IF-MIB generates and assigns an interface index (ifIndex) object value that is a unique number greater than zero to identify a physical or a logical interface. When the switch reboots or the switch software is upgraded, the switch uses this same value for the interface. For example, if the switch assigns a port 2 an ifIndex value of 10003, this value is the same after the switch reboots.

The switch uses one of the values in [Table 26-3](#) to assign an ifIndex value to an interface:

Table 26-3 *ifIndex Values*

Interface Type	ifIndex Range
SVI ¹	1–4999
EtherChannel	5000–5012
Loopback	5013–5077
Tunnel	5078–5142
Physical (such as Gigabit Ethernet or SFP ² -module interfaces)	10000–14500
Null	14501

1. SVI = switch virtual interface
2. SFP = small form-factor pluggable



Note

The switch might not use sequential values within a range.

Configuring SNMP

These sections contain this configuration information:

- [Default SNMP Configuration, page 26-7](#)
- [SNMP Configuration Guidelines, page 26-7](#)
- [Disabling the SNMP Agent, page 26-8](#)
- [Configuring Community Strings, page 26-8](#)
- [Configuring SNMP Groups and Users, page 26-10](#)
- [Configuring SNMP Notifications, page 26-12](#)
- [Setting the Agent Contact and Location Information, page 26-15](#)
- [Limiting TFTP Servers Used Through SNMP, page 26-16](#)
- [SNMP Examples, page 26-17](#)

Default SNMP Configuration

Table 26-4 shows the default SNMP configuration.

Table 26-4 Default SNMP Configuration

Feature	Default Setting
SNMP agent	Disabled ¹ .
SNMP trap receiver	None configured.
SNMP traps	None enabled except the trap for TCP connections (tty).
SNMP version	If no version keyword is present, the default is Version 1.
SNMPv3 authentication	If no keyword is entered, the default is the noauth (noAuthNoPriv) security level.
SNMP notification type	If no type is specified, all notifications are sent.

1. This is the default when the switch starts and the startup configuration does not have any **snmp-server** global configuration commands.

SNMP Configuration Guidelines

If the switch starts and the switch startup configuration has at least one **snmp-server** global configuration command, the SNMP agent is enabled.

An SNMP *group* is a table that maps SNMP users to SNMP views. An SNMP *user* is a member of an SNMP group. An SNMP *host* is the recipient of an SNMP trap operation. An SNMP *engine ID* is a name for the local or remote SNMP engine.

When configuring SNMP, follow these guidelines:

- When configuring an SNMP group, do not specify a notify view. The **snmp-server host** global configuration command autogenerates a notify view for the user and then adds it to the group associated with that user. Modifying the group's notify view affects all users associated with that group. See the *Cisco IOS Configuration Fundamentals Command Reference, Release 12.2* for information about when you should configure notify views.
- To configure a remote user, specify the IP address or port number for the remote SNMP agent of the device where the user resides.
- Before you configure remote users for a particular agent, configure the SNMP engine ID, using the **snmp-server engineID** global configuration with the **remote** option. The remote agent's SNMP engine ID and user password are used to compute the authentication and privacy digests. If you do not configure the remote engine ID first, the configuration command fails.
- When configuring SNMP informs, you need to configure the SNMP engine ID for the remote agent in the SNMP database before you can send proxy requests or informs to it.
- If a local user is not associated with a remote host, the switch does not send informs for the **auth** (authNoPriv) and the **priv** (authPriv) authentication levels.

- Changing the value of the SNMP engine ID has important side effects. A user's password (entered on the command line) is converted to an MD5 or SHA security digest based on the password and the local engine ID. The command-line password is then destroyed, as required by RFC 2274. Because of this deletion, if the value of the engine ID changes, the security digests of SNMPv3 users become invalid, and you need to reconfigure SNMP users by using the **snmp-server user *username*** global configuration command. Similar restrictions require the reconfiguration of community strings when the engine ID changes.

Disabling the SNMP Agent

Beginning in privileged EXEC mode, follow these steps to disable the SNMP agent:

	Command	Purpose
Step 1	configure terminal	Enter global configuration mode.
Step 2	no snmp-server	Disable the SNMP agent operation.
Step 3	end	Return to privileged EXEC mode.
Step 4	show running-config	Verify your entries.
Step 5	copy running-config startup-config	(Optional) Save your entries in the configuration file.

The **no snmp-server** global configuration command disables all running versions (Version 1, Version 2C, and Version 3) on the device. No specific Cisco IOS command exists to enable SNMP. The first **snmp-server** global configuration command that you enter enables all versions of SNMP.

Configuring Community Strings

You use the SNMP community string to define the relationship between the SNMP manager and the agent. The community string acts like a password to permit access to the agent on the switch. Optionally, you can specify one or more of these characteristics associated with the string:

- An access list of IP addresses of the SNMP managers that are permitted to use the community string to gain access to the agent
- A MIB view, which defines the subset of all MIB objects accessible to the given community
- Read and write or read-only permission for the MIB objects accessible to the community

Beginning in privileged EXEC mode, follow these steps to configure a community string on the switch:

	Command	Purpose
Step 1	configure terminal	Enter global configuration mode.
Step 2	snmp-server community <i>string</i> [view <i>view-name</i>] [ro rw] [<i>access-list-number</i>]	Configure the community string. <ul style="list-style-type: none"> For <i>string</i>, specify a string that acts like a password and permits access to the SNMP protocol. You can configure one or more community strings of any length. (Optional) For view, specify the view record accessible to the community. (Optional) Specify either read-only (ro) if you want authorized management stations to retrieve MIB objects, or specify read-write (rw) if you want authorized management stations to retrieve and modify MIB objects. By default, the community string permits read-only access to all objects. (Optional) For <i>access-list-number</i>, enter an IP standard access list numbered from 1 to 99 and 1300 to 1999.
Step 3	access-list <i>access-list-number</i> { deny permit } <i>source</i> [<i>source-wildcard</i>]	(Optional) If you specified an IP standard access list number in Step 2, then create the list, repeating the command as many times as necessary. <ul style="list-style-type: none"> For <i>access-list-number</i>, enter the access list number specified in Step 2. The deny keyword denies access if the conditions are matched. The permit keyword permits access if the conditions are matched. For <i>source</i>, enter the IP address of the SNMP managers that are permitted to use the community string to gain access to the agent. (Optional) For <i>source-wildcard</i>, enter the wildcard bits in dotted decimal notation to be applied to the source. Place ones in the bit positions that you want to ignore. <p>Recall that the access list is always terminated by an implicit deny statement for everything.</p>
Step 4	end	Return to privileged EXEC mode.
Step 5	show running-config	Verify your entries.
Step 6	copy running-config startup-config	(Optional) Save your entries in the configuration file.



Note

To disable access for an SNMP community, set the community string for that community to the null string (do not enter a value for the community string).

To remove a specific community string, use the **no snmp-server community** *string* global configuration command.

This example shows how to assign the string *comaccess* to SNMP, to allow read-only access, and to specify that IP access list 4 can use the community string to gain access to the switch SNMP agent:

```
Switch(config)# snmp-server community comaccess ro 4
```

Configuring SNMP Groups and Users

You can specify an identification name (engine ID) for the local or remote SNMP server engine on the switch. You can configure an SNMP server group that maps SNMP users to SNMP views, and you can add new users to the SNMP group.

Beginning in privileged EXEC mode, follow these steps to configure SNMP on the switch:

	Command	Purpose
Step 1	configure terminal	Enter global configuration mode.
Step 2	snmp-server engineID { local <i>engineid-string</i> remote <i>ip-address</i> [udp-port <i>port-number</i>] <i>engineid-string</i> }	Configure a name for either the local or remote copy of SNMP. <ul style="list-style-type: none"> The <i>engineid-string</i> is a 24-character ID string with the name of the copy of SNMP. You need not specify the entire 24-character engine ID if it has trailing zeros. Specify only the portion of the engine ID up to the point where only zeros remain in the value. For example, to configure an engine ID of 123400000000000000000000, you can enter this: snmp-server engineID local 1234 If you select remote, specify the <i>ip-address</i> of the device that contains the remote copy of SNMP and the optional User Datagram Protocol (UDP) port on the remote device. The default is 162.

Command	Purpose
<p>Step 3 <code>snmp-server group <i>groupname</i> {v1 v2c v3 {auth noauth priv}} [read <i>readview</i>] [write <i>writeview</i>] [notify <i>notifyview</i>] [access <i>access-list</i>]</code></p>	<p>Configure a new SNMP group on the remote device.</p> <ul style="list-style-type: none"> • For <i>groupname</i>, specify the name of the group. • Specify a security model: <ul style="list-style-type: none"> – v1 is the least secure of the possible security models. – v2c is the second least secure model. It allows transmission of informs and integers twice the normal width. – v3, the most secure, requires you to select an authentication level: <ul style="list-style-type: none"> auth—Enables the Message Digest 5 (MD5) and the Secure Hash Algorithm (SHA) packet authentication. noauth—Enables the noAuthNoPriv security level. This is the default if no keyword is specified. priv—Enables Data Encryption Standard (DES) packet encryption (also called <i>privacy</i>). <p>Note The priv keyword is available only when the cryptographic software image is installed.</p> <ul style="list-style-type: none"> • (Optional) Enter read <i>readview</i> with a string (not to exceed 64 characters) that is the name of the view in which you can only view the contents of the agent. • (Optional) Enter write <i>writeview</i> with a string (not to exceed 64 characters) that is the name of the view in which you enter data and configure the contents of the agent. • (Optional) Enter notify <i>notifyview</i> with a string (not to exceed 64 characters) that is the name of the view in which you specify a notify, inform, or trap. • (Optional) Enter access <i>access-list</i> with a string (not to exceed 64 characters) that is the name of the access list.

	Command	Purpose
Step 4	<code>snmp-server user username groupname {remote host [udp-port port]} {v1 [access access-list] v2c [access access-list] v3 [encrypted] [access access-list] [auth {md5 sha} auth-password]}</code>	<p>Add a new user for an SNMP group.</p> <ul style="list-style-type: none"> The <i>username</i> is the name of the user on the host that connects to the agent. The <i>groupname</i> is the name of the group to which the user is associated. Enter remote to specify a remote SNMP entity to which the user belongs and the hostname or IP address of that entity with the optional UDP port number. The default is 162. Enter the SNMP version number (v1, v2c, or v3). If you enter v3, you have these additional options: <ul style="list-style-type: none"> encrypted specifies that the password appears in encrypted format. This keyword is available only when the v3 keyword is specified. auth is an authentication level setting session that can be either the HMAC-MD5-96 (md5) or the HMAC-SHA-96 (sha) authentication level and requires a password string (not to exceed 64 characters). (Optional) Enter access access-list with a string (not to exceed 64 characters) that is the name of the access list.
Step 5	<code>end</code>	Return to privileged EXEC mode.
Step 6	<code>show running-config</code>	Verify your entries.
Step 7	<code>copy running-config startup-config</code>	(Optional) Save your entries in the configuration file.

Configuring SNMP Notifications

A trap manager is a management station that receives and processes traps. Traps are system alerts that the switch generates when certain events occur. By default, no trap manager is defined, and no traps are sent. Switches running this Cisco IOS release can have an unlimited number of trap managers.



Note

Many commands use the word *traps* in the command syntax. Unless there is an option in the command to select either traps or informs, the keyword *traps* refers to either traps, informs, or both. Use the **snmp-server host** global configuration command to specify whether to send SNMP notifications as traps or informs.

Table 26-5 describes the supported switch traps (notification types). You can enable any or all of these traps and configure a trap manager to receive them.

Table 26-5 Switch Notification Types

Notification Type Keyword	Description
bridge	Generates STP bridge MIB traps.
cluster	Generates a trap when the cluster configuration changes.
config	Generates a trap for SNMP configuration changes.

Table 26-5 Switch Notification Types (continued)

Notification Type Keyword	Description
copy-config	Generates a trap for SNMP copy configuration changes.
entity	Generates a trap for SNMP entity changes.
envmon	Generates environmental monitor traps. You can enable any or all of these environmental traps: fan, shutdown, status, supply, temperature.
errdisable	Generates a trap for a port VLAN errdisabled. You can also set a maximum trap rate per minute. The range is from 0 to 10000; the default is 0, which means there is no rate limit.
flash	Generates SNMP FLASH notifications.
hsrp	Generates a trap for Hot Standby Router Protocol (HSRP) changes.
ipmulticast	Generates a trap for IP multicast routing changes.
mac-notification	Generates a trap for MAC address notifications.
msdp	Generates a trap for Multicast Source Discovery Protocol (MSDP) changes.
ospf	Generates a trap for Open Shortest Path First (OSPF) changes. You can enable any or all of these traps: Cisco specific, errors, link-state advertisement, rate limit, retransmit, and state changes.
pim	Generates a trap for Protocol-Independent Multicast (PIM) changes. You can enable any or all of these traps: invalid PIM messages, neighbor changes, and rendezvous point (RP)-mapping changes.
port-security	<p>Generates SNMP port security traps. You can also set a maximum trap rate per second. The range is from 0 to 1000; the default is 0, which means that there is no rate limit.</p> <p>Note When you configure a trap by using the notification type port-security, configure the port security trap first, and then configure the port security trap rate:</p> <ul style="list-style-type: none"> • snmp-server enable traps port-security • snmp-server enable traps port-security trap-rate rate
rtr	Generates a trap for the SNMP Response Time Reporter (RTR).
snmp	Generates a trap for SNMP-type notifications for authentication, cold start, warm start, link up or link down.
storm-control	Generates a trap for SNMP storm-control. You can also set a maximum trap rate per second. The range is from 0 to 1000; the default is 0 (no limit is imposed; a trap is sent at every occurrence).
stpx	Generates SNMP STP Extended MIB traps.
syslog	Generates SNMP syslog traps.
tty	Generates a trap for TCP connections. This trap is enabled by default.
vlan-membership	Generates a trap for SNMP VLAN membership changes.
vlancreate	Generates SNMP VLAN created traps.
vlandelete	Generates SNMP VLAN deleted traps.
vtp	Generates a trap for VLAN Trunking Protocol (VTP) changes.

**Note**

Though visible in the command-line help strings, the **cpu [threshold]**, **insertion**, and **removal** keywords are not supported. To enable the sending of SNMP inform notifications, use the **snmp-server enable traps** global configuration command combined with the **snmp-server host host-addr informs** global configuration command.

You can use the **snmp-server host** global configuration command to a specific host to receive the notification types listed in [Table 26-5](#).

Beginning in privileged EXEC mode, follow these steps to configure the switch to send traps or informs to a host:

	Command	Purpose
Step 1	configure terminal	Enter global configuration mode.
Step 2	snmp-server engineID remote ip-address engineid-string	Specify the engine ID for the remote host.
Step 3	snmp-server user username groupname {remote host [udp-port port]} {v1 [access access-list] v2c [access access-list] v3 [encrypted] [access access-list] [auth {md5 sha} auth-password]}	Configure an SNMP user to be associated with the remote host created in Step 2. Note You cannot configure a remote user for an address without first configuring the engine ID for the remote host. Otherwise, you receive an error message, and the command is not executed.
Step 4	snmp-server group groupname {v1 v2c v3 {auth noauth priv}} [read readview] [write writeview] [notify notifyview] [access access-list]	Configure an SNMP group.
Step 5	snmp-server host host-addr [informs traps] [version {1 2c 3} {auth noauth priv}]] community-string [notification-type]	Specify the recipient of an SNMP trap operation. <ul style="list-style-type: none"> For <i>host-addr</i>, specify the name or Internet address of the host (the targeted recipient). (Optional) Enter informs to send SNMP informs to the host. (Optional) Enter traps (the default) to send SNMP traps to the host. (Optional) Specify the SNMP version (1, 2c, or 3). SNMPv1 does not support informs. (Optional) For Version 3, select authentication level auth, noauth, or priv. Note The priv keyword is available only when the cryptographic software image is installed. <ul style="list-style-type: none"> For <i>community-string</i>, when version 1 or version 2c is specified, enter the password-like community string sent with the notification operation. When version 3 is specified, enter the SNMPv3 username. (Optional) For <i>notification-type</i>, use the keywords listed in Table 26-5 on page 26-12. If no type is specified, all notifications are sent.

	Command	Purpose
Step 6	snmp-server enable traps <i>notification-types</i>	Enable the switch to send traps or informs and specify the type of notifications to be sent. For a list of notification types, see Table 26-5 on page 26-12 , or enter snmp-server enable traps ? To enable multiple types of traps, you must enter a separate snmp-server enable traps command for each trap type. Note When you configure a trap by using the notification type port-security , configure the port security trap first, and then configure the port security trap rate: <ul style="list-style-type: none"> • snmp-server enable traps port-security • snmp-server enable traps port-security trap-rate rate
Step 7	snmp-server trap-source <i>interface-id</i>	(Optional) Specify the source interface, which provides the IP address for the trap message. This command also sets the source IP address for informs.
Step 8	snmp-server queue-length <i>length</i>	(Optional) Establish the message queue length for each trap host. The range is 1 to 1000; the default is 10.
Step 9	snmp-server trap-timeout <i>seconds</i>	(Optional) Define how often to resend trap messages. The range is 1 to 1000; the default is 30 seconds.
Step 10	end	Return to privileged EXEC mode.
Step 11	show running-config	Verify your entries.
Step 12	copy running-config startup-config	(Optional) Save your entries in the configuration file.

The **snmp-server host** command specifies which hosts receive the notifications. The **snmp-server enable trap** command globally enables the mechanism for the specified notification (for traps and informs). To enable a host to receive an inform, you must configure an **snmp-server host informs** command for the host and globally enable informs by using the **snmp-server enable traps** command.

To remove the specified host from receiving traps, use the **no snmp-server host** *host* global configuration command. The **no snmp-server host** command with no keywords disables traps, but not informs, to the host. To disable informs, use the **no snmp-server host informs** global configuration command. To disable a specific trap type, use the **no snmp-server enable traps** *notification-types* global configuration command.

Setting the Agent Contact and Location Information

Beginning in privileged EXEC mode, follow these steps to set the system contact and location of the SNMP agent so that these descriptions can be accessed through the configuration file:

	Command	Purpose
Step 1	configure terminal	Enter global configuration mode.
Step 2	snmp-server contact <i>text</i>	Set the system contact string. For example: snmp-server contact Dial System Operator at beeper 21555.

	Command	Purpose
Step 3	<code>snmp-server location text</code>	Set the system location string. For example: <code>snmp-server location Building 3/Room 222</code>
Step 4	<code>end</code>	Return to privileged EXEC mode.
Step 5	<code>show running-config</code>	Verify your entries.
Step 6	<code>copy running-config startup-config</code>	(Optional) Save your entries in the configuration file.

Limiting TFTP Servers Used Through SNMP

Beginning in privileged EXEC mode, follow these steps to limit the TFTP servers used for saving and loading configuration files through SNMP to the servers specified in an access list:

	Command	Purpose
Step 1	<code>configure terminal</code>	Enter global configuration mode.
Step 2	<code>snmp-server tftp-server-list access-list-number</code>	Limit TFTP servers used for configuration file copies through SNMP to the servers in the access list. For <i>access-list-number</i> , enter an IP standard access list numbered from 1 to 99 and 1300 to 1999.
Step 3	<code>access-list access-list-number {deny permit} source [source-wildcard]</code>	Create a standard access list, repeating the command as many times as necessary. <ul style="list-style-type: none"> For <i>access-list-number</i>, enter the access list number specified in Step 2. The deny keyword denies access if the conditions are matched. The permit keyword permits access if the conditions are matched. For <i>source</i>, enter the IP address of the TFTP servers that can access the switch. (Optional) For <i>source-wildcard</i>, enter the wildcard bits, in dotted decimal notation, to be applied to the source. Place ones in the bit positions that you want to ignore. Recall that the access list is always terminated by an implicit deny statement for everything.
Step 4	<code>end</code>	Return to privileged EXEC mode.
Step 5	<code>show running-config</code>	Verify your entries.
Step 6	<code>copy running-config startup-config</code>	(Optional) Save your entries in the configuration file.

SNMP Examples

This example shows how to enable all versions of SNMP. The configuration permits any SNMP manager to access all objects with read-only permissions using the community string *public*. This configuration does not cause the switch to send any traps.

```
Switch(config)# snmp-server community public
```

This example shows how to permit any SNMP manager to access all objects with read-only permission using the community string *public*. The switch also sends VTP traps to the hosts 192.180.1.111 and 192.180.1.33 using SNMPv1 and to the host 192.180.1.27 using SNMPv2C. The community string *public* is sent with the traps.

```
Switch(config)# snmp-server community public
Switch(config)# snmp-server enable traps vtp
Switch(config)# snmp-server host 192.180.1.27 version 2c public
Switch(config)# snmp-server host 192.180.1.111 version 1 public
Switch(config)# snmp-server host 192.180.1.33 public
```

This example shows how to allow read-only access for all objects to members of access list 4 that use the *comaccess* community string. No other SNMP managers have access to any objects. SNMP Authentication Failure traps are sent by SNMPv2C to the host *cisco.com* using the community string *public*.

```
Switch(config)# snmp-server community comaccess ro 4
Switch(config)# snmp-server enable traps snmp authentication
Switch(config)# snmp-server host cisco.com version 2c public
```

This example shows how to send Entity MIB traps to the host *cisco.com*. The community string is restricted. The first line enables the switch to send Entity MIB traps in addition to any traps previously enabled. The second line specifies the destination of these traps and overwrites any previous **snmp-server host** commands for the host *cisco.com*.

```
Switch(config)# snmp-server enable traps entity
Switch(config)# snmp-server host cisco.com restricted entity
```

This example shows how to enable the switch to send all traps to the host *myhost.cisco.com* using the community string *public*:

```
Switch(config)# snmp-server enable traps
Switch(config)# snmp-server host myhost.cisco.com public
```

This example shows how to associate a user with a remote host and to send **auth** (authNoPriv) authentication-level informs when the user enters global configuration mode:

```
Switch(config)# snmp-server engineID remote 192.180.1.27 00000063000100a1c0b4011b
Switch(config)# snmp-server group authgroup v3 auth
Switch(config)# snmp-server user authuser authgroup remote 192.180.1.27 v3 auth md5
mypassword
Switch(config)# snmp-server user authuser authgroup v3 auth md5 mypassword
Switch(config)# snmp-server host 192.180.1.27 informs version 3 auth authuser config
Switch(config)# snmp-server enable traps
Switch(config)# snmp-server inform retries 0
```

Displaying SNMP Status

To display SNMP input and output statistics, including the number of illegal community string entries, errors, and requested variables, use the **show snmp** privileged EXEC command. You also can use the other privileged EXEC commands in [Table 26-6](#) to display SNMP information. For information about the fields in the displays, see the *Cisco IOS Configuration Fundamentals Command Reference, Release 12.2*.

Table 26-6 **Commands for Displaying SNMP Information**

Feature	Default Setting
show snmp	Displays SNMP statistics.
show snmp engineID [local remote]	Displays information on the local SNMP engine and all remote engines that have been configured on the device.
show snmp group	Displays information on each SNMP group on the network.
show snmp pending	Displays information on pending SNMP requests.
show snmp sessions	Displays information on the current SNMP sessions.
show snmp user	Displays information on each SNMP user name in the SNMP users table.



CHAPTER 27

Configuring Cisco IOS IP SLAs Operations



Note

This chapter describes how to use Cisco IOS IP Service Level Agreements (SLAs) on the Catalyst 2960 switch. Cisco IP SLAs is a part of Cisco IOS software that allows Cisco customers to analyze IP service levels for IP applications and services by using active traffic monitoring—the generation of traffic in a continuous, reliable, and predictable manner—for measuring network performance. With Cisco IOS IP SLAs, service provider customers can measure and provide service level agreements, and enterprise customers can verify service levels, verify outsourced service level agreements, and understand network performance. Cisco IOS IP SLAs can perform network assessments, verify quality of service (QoS), ease the deployment of new services, and assist with network troubleshooting. The Catalyst 2960 switch supports only IP SLAs responder functionality and must be configured with another device that supports full IP SLAs functionality.

For more information about IP SLAs, see the *Cisco IOS IP SLAs Configuration Guide, Release 12.4T* at this URL:

http://www.cisco.com/en/US/products/ps6441/products_configuration_guide_book09186a0080707055.html

For command syntax information, see the command reference at this URL:

http://www.cisco.com/en/US/products/ps6441/products_command_reference_book09186a008049739b.html

This chapter consists of these sections:

- [Understanding Cisco IOS IP SLAs, page 27-1](#)
- [Configuring IP SLAs Operations, page 27-5](#)
- [Monitoring IP SLAs Operations, page 27-7](#)

Understanding Cisco IOS IP SLAs

Cisco IOS IP SLAs sends data across the network to measure performance between multiple network locations or across multiple network paths. It simulates network data and IP services and collects network performance information in real time. Cisco IOS IP SLAs generates and analyzes traffic either between Cisco IOS devices or from a Cisco IOS device to a remote IP device such as a network application server. Measurements provided by the various Cisco IOS IP SLAs operations can be used for troubleshooting, for problem analysis, and for designing network topologies.

Depending on the specific Cisco IOS IP SLAs operation, various network performance statistics are monitored within the Cisco device and stored in both command-line interface (CLI) and Simple Network Management Protocol (SNMP) MIBs. IP SLAs packets have configurable IP and application layer

options such as source and destination IP address, User Datagram Protocol (UDP)/TCP port numbers, a type of service (ToS) byte (including Differentiated Services Code Point [DSCP] and IP Prefix bits), Virtual Private Network (VPN) routing/forwarding instance (VRF), and URL web address.

Because Cisco IP SLAs is Layer 2 transport independent, you can configure end-to-end operations over disparate networks to best reflect the metrics that an end user is likely to experience. IP SLAs collects a unique subset of these performance metrics:

- Delay (both round-trip and one-way)
- Jitter (directional)
- Packet loss (directional)
- Packet sequencing (packet ordering)
- Path (per hop)
- Connectivity (directional)
- Server or website download time

Because Cisco IOS IP SLAs is SNMP-accessible, it can also be used by performance-monitoring applications like CiscoWorks Internetwork Performance Monitor (IPM) and other third-party Cisco partner performance management products. You can find more details about network management products that use Cisco IOS IP SLAs at this URL:

<http://www.cisco.com/go/ipsla>

Using IP SLAs can provide these benefits:

- Service-level agreement monitoring, measurement, and verification.
- Network performance monitoring
 - Measures the jitter, latency, or packet loss in the network.
 - Provides continuous, reliable, and predictable measurements.
- IP service network health assessment to verify that the existing QoS is sufficient for new IP services.
- Edge-to-edge network availability monitoring for proactive verification and connectivity testing of network resources (for example, shows the network availability of an NFS server used to store business critical data from a remote site).
- Troubleshooting of network operation by providing consistent, reliable measurement that immediately identifies problems and saves troubleshooting time.
- Multiprotocol Label Switching (MPLS) performance monitoring and network verification (if the switch supports MPLS)

This section includes this information about IP SLAs functionality:

- [Using Cisco IOS IP SLAs to Measure Network Performance, page 27-2](#)
- [IP SLAs Responder and IP SLAs Control Protocol, page 27-3](#)
- [Response Time Computation for IP SLAs, page 27-4](#)

Using Cisco IOS IP SLAs to Measure Network Performance

You can use IP SLAs to monitor the performance between any area in the network—core, distribution, and edge—without deploying a physical probe. It uses generated traffic to measure network performance between two networking devices. [Figure 27-1](#) shows how IP SLAs begins when the source device sends a generated packet to the destination device. After the destination device receives the packet, depending

on the type of IP SLAs operation, it responds with time-stamp information for the source to make the calculation on performance metrics. An IP SLAs operation performs a network measurement from the source device to a destination in the network using a specific protocol such as UDP.

Figure 27-1 Cisco IOS IP SLAs Operation

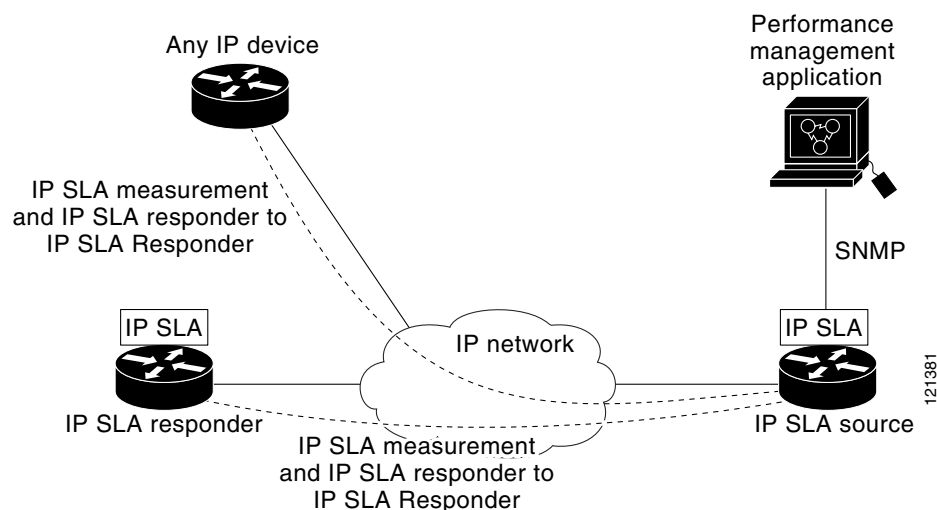

To implement IP SLAs network performance measurement, you need to perform these tasks:

1. Enable the IP SLAs responder, if required.
2. Configure the required IP SLAs operation type.
3. Configure any options available for the specified operation type.
4. Configure threshold conditions, if required.
5. Schedule the operation to run, then let the operation run for a period of time to gather statistics.
6. Display and interpret the results of the operation using the Cisco IOS CLI or a network management system (NMS) system with SNMP.

For more information about IP SLAs operations, see the operation-specific chapters in the *Cisco IOS IP SLAs Configuration Guide* at this URL:

http://www.cisco.com/en/US/products/ps6441/products_configuration_guide_book09186a0080707055.html



Note

The switch does not support Voice over IP (VoIP) service level analysis or IP service level analysis using DLSw+ operation. Before configuring any IP SLAs application, you can use the **show ip sla application** privileged EXEC command to verify that the operation type is supported on your software image.

IP SLAs Responder and IP SLAs Control Protocol

The IP SLAs responder is a component embedded in the destination Cisco device that allows the system to anticipate and respond to IP SLAs request packets. The responder provides accurate measurements without the need for dedicated probes. The responder uses the Cisco IOS IP SLAs Control Protocol to provide a mechanism through which it can be notified on which port it should listen and respond. Only a Cisco IOS device can be a source for a destination IP SLAs Responder.

**Note**

The IP SLAs responder can be a Cisco IOS Layer 2, responder-configurable switch, such as a Catalyst 2960 or Cisco ME 2400 switch. The responder does not need to support full IP SLAs functionality.

Figure 27-1 shows where the Cisco IOS IP SLAs responder fits in the IP network. The responder listens on a specific port for control protocol messages sent by an IP SLAs operation. Upon receipt of the control message, it enables the specified UDP or TCP port for the specified duration. During this time, the responder accepts the requests and responds to them. It disables the port after it responds to the IP SLAs packet, or when the specified time expires. MD5 authentication for control messages is available for added security.

You do not need to enable the responder on the destination device for all IP SLAs operations. For example, a responder is not required for services that are already provided by the destination router (such as Telnet or HTTP). You cannot configure the IP SLAs responder on non-Cisco devices and Cisco IOS IP SLAs can send operational packets only to services native to those devices.

Response Time Computation for IP SLAs

Switches and routers can take tens of milliseconds to process incoming packets due to other high priority processes. This delay affects the response times because the test-packet reply might be in a queue while waiting to be processed. In this situation, the response times would not accurately represent true network delays. IP SLAs minimizes these processing delays on the source device as well as on the target device (if the responder is being used) to determine true round-trip times. IP SLAs test packets use time stamping to minimize the processing delays.

When the IP SLAs responder is enabled, it allows the target device to take time stamps when the packet arrives on the interface at interrupt level and again just as it is leaving, eliminating the processing time. This time stamping is made with a granularity of sub-milliseconds (ms).

Figure 27-2 demonstrates how the responder works. Four time stamps are taken to make the calculation for round-trip time. At the target router, with the responder functionality enabled, time stamp 2 (TS2) is subtracted from time stamp 3 (TS3) to produce the time spent processing the test packet as represented by delta. This delta value is then subtracted from the overall round-trip time. Notice that the same principle is applied by IP SLAs on the source router where the incoming time stamp 4 (TS4) is also taken at the interrupt level to allow for greater accuracy.

Figure 27-2 Cisco IOS IP SLAs Responder Time Stamping

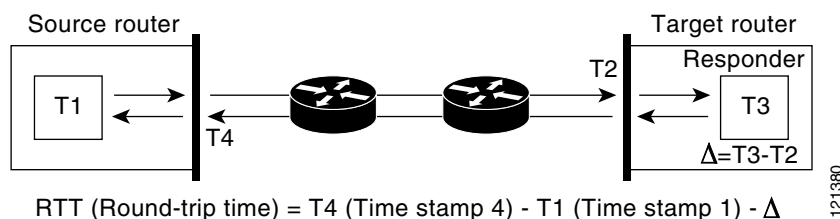

An additional benefit of the two time stamps at the target device is the ability to track one-way delay, jitter, and directional packet loss. Because much network behavior is asynchronous, it is critical to have these statistics. However, to capture one-way delay measurements, you must configure both the source router and target router with Network Time Protocol (NTP) so that the source and target are synchronized to the same clock source. One-way jitter measurements do not require clock synchronization.

Configuring IP SLAs Operations

This section does not include configuration information for all available operations as the configuration information details are included in the *Cisco IOS IP SLAs Configuration Guide*. It includes only the procedure for configuring the responder, and the Catalyst 2960 switch includes only responder support. For details about configuring other operations, see the *Cisco IOS IP SLAs Configuration Guide* at this URL:

http://www.cisco.com/en/US/products/ps6441/products_configuration_guide_book09186a0080707055.html

This section includes this information:

- [Default Configuration, page 27-5](#)
- [Configuration Guidelines, page 27-5](#)
- [Configuring the IP SLAs Responder, page 27-6](#)

Default Configuration

No IP SLAs operations are configured.

Configuration Guidelines

For information on the IP SLAs commands, see the *Cisco IOS IP SLAs Command Reference, Release 12.4T* command reference at this URL:

http://www.cisco.com/en/US/products/ps6441/products_command_reference_book09186a008049739b.html

For detailed descriptions and configuration procedures, see the *Cisco IOS IP SLAs Configuration Guide, Release 12.4T* at this URL:

http://www.cisco.com/en/US/products/ps6441/products_configuration_guide_book09186a0080707055.html

Configuring the IP SLAs Responder

The IP SLAs responder is available only on Cisco IOS software-based devices, including some Layer 2 switches that do not support full IP SLAs functionality, such as the Catalyst 2960 or the Cisco ME 2400 switch. Beginning in privileged EXEC mode, follow these steps to configure the IP SLAs responder on the target device (the operational target):

	Command	Purpose
Step 1	configure terminal	Enter global configuration mode.
Step 2	ip sla responder {tcp-connect udp-echo} ipaddress <i>ip-address</i> port <i>port-number</i>	Configure the switch as an IP SLAs responder. The optional keywords have these meanings: <ul style="list-style-type: none"> • tcp-connect—Enable the responder for TCP connect operations. • udp-echo—Enable the responder for User Datagram Protocol (UDP) echo or jitter operations. • ipaddress <i>ip-address</i>—Enter the destination IP address. • port <i>port-number</i>—Enter the destination port number. Note The IP address and port number must match those configured on the source device for the IP SLAs operation.
Step 3	end	Return to privileged EXEC mode.
Step 4	show ip sla responder	Verify the IP SLAs responder configuration on the device.
Step 5	copy running-config startup-config	(Optional) Save your entries in the configuration file.

To disable the IP SLAs responder, enter the **no ip sla responder** global configuration command. This example shows how to configure the device as a responder for the UDP jitter IP SLAs operation in the next procedure:

```
Switch(config)# ip sla responder udp-echo 172.29.139.134 5000
```



Note

For the IP SLAs responder to function, you must also configure a source device, such as a Catalyst 3750 or Catalyst 3560, that has full IP SLAs support. Refer to the documentation for the source device for configuration information.

Monitoring IP SLAs Operations

Use the User EXEC or Privileged EXEC commands in [Table 27-1](#) to display IP SLAs operations configuration.

Table 27-1 *Monitoring IP SLAs Operations*

Command	Purpose
<code>show ip sla authentication</code>	Display IP SLAs authentication information.
<code>show ip sla responder</code>	Display information about the IP SLAs responder.



CHAPTER 28

Configuring QoS

This chapter describes how to configure quality of service (QoS) by using automatic QoS (auto-QoS) commands or by using standard QoS commands on the Catalyst 2960 switch. With QoS, you can provide preferential treatment to certain types of traffic at the expense of others. Without QoS, the switch offers best-effort service to each packet, regardless of the packet contents or size. It sends the packets without any assurance of reliability, delay bounds, or throughput.

You can configure QoS only on physical ports. You configure the QoS settings, such as classification, queueing, and scheduling, and apply a policy map to a port.



Note

For complete syntax and usage information for the commands used in this chapter, see the command reference for this release.

This chapter consists of these sections:

- [Understanding QoS, page 28-1](#)
- [Configuring Auto-QoS, page 28-19](#)
- [Displaying Auto-QoS Information, page 28-29](#)
- [Configuring Standard QoS, page 28-29](#)
- [Displaying Standard QoS Information, page 28-69](#)

The switch supports some of the modular QoS CLI (MQC) commands. For more information about the MQC commands, see the “Modular Quality of Service Command-Line Interface Overview” at this site:

http://www.cisco.com/en/US/products/sw/iosswrel/ps1835/products_configuration_guide_chapter09186a00800bd908.html

Understanding QoS

Typically, networks operate on a best-effort delivery basis, which means that all traffic has equal priority and an equal chance of being delivered in a timely manner. When congestion occurs, all traffic has an equal chance of being dropped.

When you configure the QoS feature, you can select specific network traffic, prioritize it according to its relative importance, and use congestion-management and congestion-avoidance techniques to provide preferential treatment. Implementing QoS in your network makes network performance more predictable and bandwidth utilization more effective.

The QoS implementation is based on the Differentiated Services (Diff-Serv) architecture, an emerging standard from the Internet Engineering Task Force (IETF). This architecture specifies that each packet is classified upon entry into the network.

The classification is carried in the IP packet header, using 6 bits from the deprecated IP type of service (ToS) field to carry the classification (*class*) information. Classification can also be carried in the Layer 2 frame. These special bits in the Layer 2 frame or a Layer 3 packet are described here and shown in [Figure 28-1](#):

- Prioritization bits in Layer 2 frames:

Layer 2 Inter-Switch Link (ISL) frame headers have a 1-byte User field that carries an IEEE 802.1p class of service (CoS) value in the three least-significant bits. On ports configured as Layer 2 ISL trunks, all traffic is in ISL frames.

Layer 2 IEEE 802.1Q frame headers have a 2-byte Tag Control Information field that carries the CoS value in the three most-significant bits, which are called the User Priority bits. On ports configured as Layer 2 IEEE 802.1Q trunks, all traffic is in IEEE 802.1Q frames except for traffic in the native VLAN.

Other frame types cannot carry Layer 2 CoS values.

Layer 2 CoS values range from 0 for low priority to 7 for high priority.

- Prioritization bits in Layer 3 packets:

Layer 3 IP packets can carry either an IP precedence value or a Differentiated Services Code Point (DSCP) value. QoS supports the use of either value because DSCP values are backward-compatible with IP precedence values.

IP precedence values range from 0 to 7.

DSCP values range from 0 to 63.

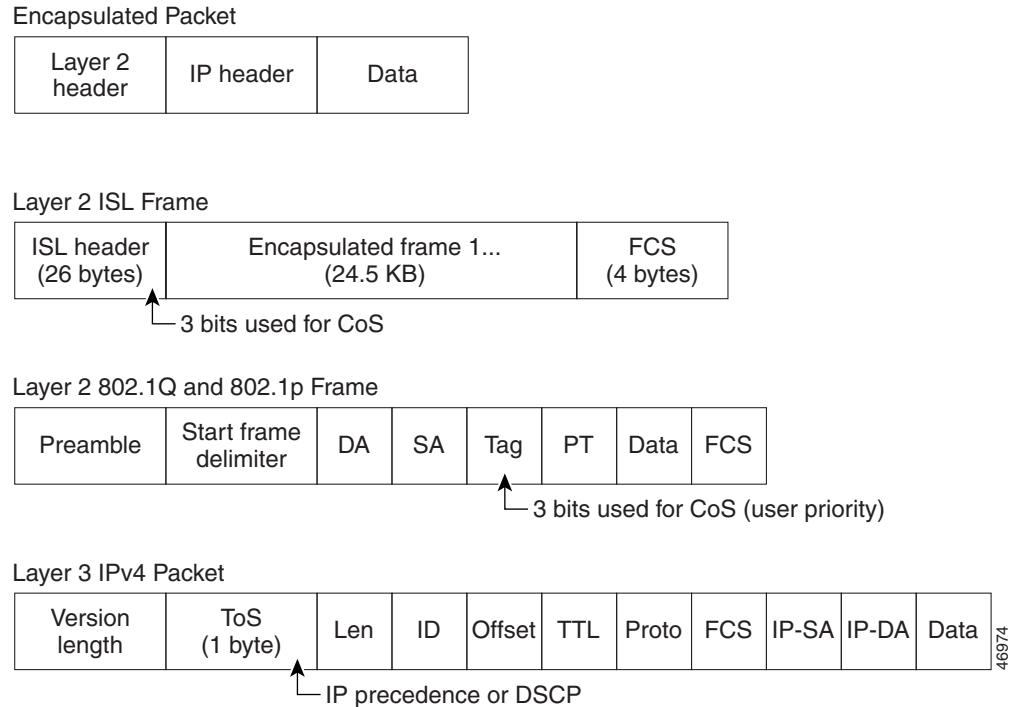

Note IPv6 QoS is not supported in this release.

Figure 28-1 QoS Classification Layers in Frames and Packets

All switches and routers that access the Internet rely on the class information to provide the same forwarding treatment to packets with the same class information and different treatment to packets with different class information. The class information in the packet can be assigned by end hosts or by switches or routers along the way, based on a configured policy, detailed examination of the packet, or both. Detailed examination of the packet is expected to happen closer to the edge of the network so that the core switches and routers are not overloaded with this task.

Switches and routers along the path can use the class information to limit the amount of resources allocated per traffic class. The behavior of an individual device when handling traffic in the DiffServ architecture is called per-hop behavior. If all devices along a path provide a consistent per-hop behavior, you can construct an end-to-end QoS solution.

Implementing QoS in your network can be a simple or complex task and depends on the QoS features offered by your internetworking devices, the traffic types and patterns in your network, and the granularity of control that you need over incoming and outgoing traffic.

Basic QoS Model

To implement QoS, the switch must distinguish packets or flow from one another (classify), assign a label to indicate the given quality of service as the packets move through the switch, make the packets comply with the configured resource usage limits (police and mark), and provide different treatment (queue and schedule) in all situations where resource contention exists. The switch also needs to ensure that traffic sent from it meets a specific traffic profile (shape).

Figure 28-2 shows the basic QoS model. Actions at the ingress port include classifying traffic, policing, marking, queueing, and scheduling:

- Classifying a distinct path for a packet by associating it with a QoS label. The switch maps the CoS or DSCP in the packet to a QoS label to distinguish one kind of traffic from another. The QoS label that is generated identifies all future QoS actions to be performed on this packet. For more information, see the “[Classification](#)” section on page 28-5.
- Policing determines whether a packet is in or out of profile by comparing the rate of the incoming traffic to the configured policer. The policer limits the bandwidth consumed by a flow of traffic. The result is passed to the marker. For more information, see the “[Policing and Marking](#)” section on page 28-8.
- Marking evaluates the policer and configuration information for the action to be taken when a packet is out of profile and determines what to do with the packet (pass through a packet without modification, mark down the QoS label in the packet, or drop the packet). For more information, see the “[Policing and Marking](#)” section on page 28-8.
- Queueing evaluates the QoS label and the corresponding DSCP or CoS value to select into which of the two ingress queues to place a packet. Queueing is enhanced with the weighted tail-drop (WTD) algorithm, a congestion-avoidance mechanism. If the threshold is exceeded, the packet is dropped. For more information, see the “[Queueing and Scheduling Overview](#)” section on page 28-12.
- Scheduling services the queues based on their configured shaped round robin (SRR) weights. One of the ingress queues is the priority queue, and SRR services it for its configured share before servicing the other queue. For more information, see the “[SRR Shaping and Sharing](#)” section on page 28-13.

Actions at the egress port include queueing and scheduling:

- Queueing evaluates the QoS packet label and the corresponding DSCP or CoS value before selecting which of the four egress queues to use. Because congestion can occur when multiple ingress ports simultaneously send data to an egress port, WTD differentiates traffic classes and subjects the packets to different thresholds based on the QoS label. If the threshold is exceeded, the packet is dropped. For more information, see the “[Queueing and Scheduling Overview](#)” section on page 28-12.
- Scheduling services the four egress queues based on their configured SRR shared or shaped weights. One of the queues (queue 1) can be the expedited queue, which is serviced until empty before the other queues are serviced.

Figure 28-2 Basic QoS Model

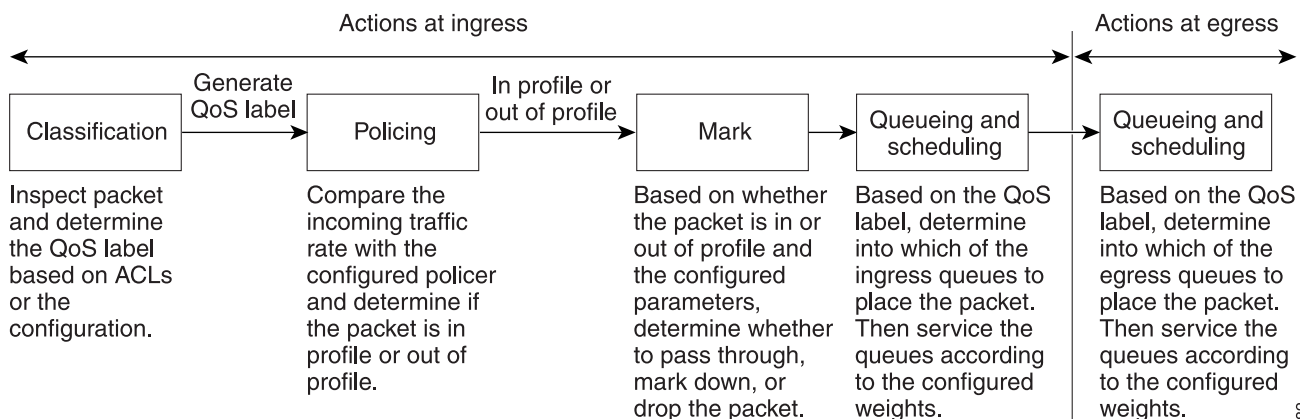

Classification

Classification is the process of distinguishing one kind of traffic from another by examining the fields in the packet. Classification is enabled only if QoS is globally enabled on the switch. By default, QoS is globally disabled, so no classification occurs.

During classification, the switch performs a lookup and assigns a QoS label to the packet. The QoS label identifies all QoS actions to be performed on the packet and from which queue the packet is sent.

The QoS label is based on the DSCP or the CoS value in the packet and decides the queuing and scheduling actions to perform on the packet. The label is mapped according to the trust setting and the packet type as shown in [Figure 28-3 on page 28-6](#).

You specify which fields in the frame or packet that you want to use to classify incoming traffic. For non-IP traffic, you have these classification options as shown in [Figure 28-3](#):

- Trust the CoS value in the incoming frame (configure the port to trust CoS). Then use the configurable CoS-to-DSCP map to generate a DSCP value for the packet. Layer 2 ISL frame headers carry the CoS value in the 3 least-significant bits of the 1-byte User field. Layer 2 IEEE 802.1Q frame headers carry the CoS value in the 3 most-significant bits of the Tag Control Information field. CoS values range from 0 for low priority to 7 for high priority.
- Trust the DSCP or trust IP precedence value in the incoming frame. These configurations are meaningless for non-IP traffic. If you configure a port with either of these options and non-IP traffic is received, the switch assigns a CoS value and generates an internal DSCP value from the CoS-to-DSCP map. The switch uses the internal DSCP value to generate a CoS value representing the priority of the traffic.
- Perform the classification based on a configured Layer 2 MAC access control list (ACL), which can examine the MAC source address, the MAC destination address, and other fields. If no ACL is configured, the packet is assigned 0 as the DSCP and CoS values, which means best-effort traffic. Otherwise, the policy-map action specifies a DSCP or CoS value to assign to the incoming frame.

For IP traffic, you have these classification options as shown in [Figure 28-3](#):

- Trust the DSCP value in the incoming packet (configure the port to trust DSCP), and assign the same DSCP value to the packet. The IETF defines the 6 most-significant bits of the 1-byte ToS field as the DSCP. The priority represented by a particular DSCP value is configurable. DSCP values range from 0 to 63.

For ports that are on the boundary between two QoS administrative domains, you can modify the DSCP to another value by using the configurable DSCP-to-DSCP-mutation map.

- Trust the IP precedence value in the incoming packet (configure the port to trust IP precedence), and generate a DSCP value for the packet by using the configurable IP-precedence-to-DSCP map. The IP Version 4 specification defines the 3 most-significant bits of the 1-byte ToS field as the IP precedence. IP precedence values range from 0 for low priority to 7 for high priority.
- Trust the CoS value (if present) in the incoming packet, and generate a DSCP value for the packet by using the CoS-to-DSCP map. If the CoS value is not present, use the default port CoS value.
- Perform the classification based on a configured IP standard or an extended ACL, which examines various fields in the IP header. If no ACL is configured, the packet is assigned 0 as the DSCP and CoS values, which means best-effort traffic. Otherwise, the policy-map action specifies a DSCP or CoS value to assign to the incoming frame.

For information on the maps described in this section, see the “[Mapping Tables](#)” section on page 28-11. For configuration information on port trust states, see the “[Configuring Classification Using Port Trust States](#)” section on page 28-34.

After classification, the packet is sent to the policing, marking, and the ingress queuing and scheduling stages.

Figure 28-3 Classification Flowchart

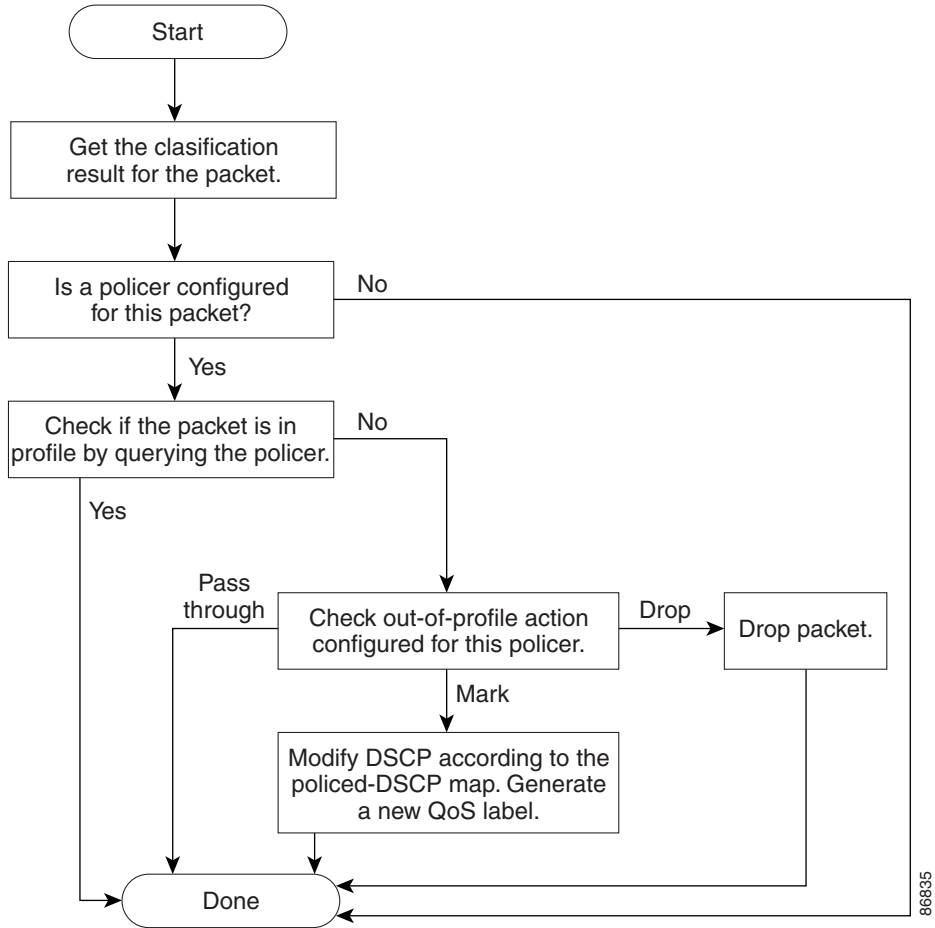

86835

Classification Based on QoS ACLs

You can use IP standard, IP extended, or Layer 2 MAC ACLs to define a group of packets with the same characteristics (*class*). In the QoS context, the permit and deny actions in the access control entries (ACEs) have different meanings than with security ACLs:

- If a match with a permit action is encountered (first-match principle), the specified QoS-related action is taken.
- If a match with a deny action is encountered, the ACL being processed is skipped, and the next ACL is processed.
- If no match with a permit action is encountered and all the ACEs have been examined, no QoS processing occurs on the packet, and the switch offers best-effort service to the packet.
- If multiple ACLs are configured on a port, the lookup stops after the packet matches the first ACL with a permit action, and QoS processing begins.

**Note**

When creating an access list, remember that, by default, the end of the access list contains an implicit deny statement for everything if it did not find a match before reaching the end.

After a traffic class has been defined with the ACL, you can attach a policy to it. A policy might contain multiple classes with actions specified for each one of them. A policy might include commands to classify the class as a particular aggregate (for example, assign a DSCP) or rate-limit the class. This policy is then attached to a particular port on which it becomes effective.

You implement IP ACLs to classify IP traffic by using the **access-list** global configuration command; you implement Layer 2 MAC ACLs to classify non-IP traffic by using the **mac access-list extended** global configuration command. For configuration information, see the [“Configuring a QoS Policy” section on page 28-40](#).

Classification Based on Class Maps and Policy Maps

A class map is a mechanism that you use to name a specific traffic flow (or class) and to isolate it from all other traffic. The class map defines the criteria used to match against a specific traffic flow to further classify it. The criteria can include matching the access group defined by the ACL or matching a specific list of DSCP or IP precedence values. If you have more than one type of traffic that you want to classify, you can create another class map and use a different name. After a packet is matched against the class-map criteria, you further classify it through the use of a policy map.

A policy map specifies which traffic class to act on. Actions can include trusting the CoS, DSCP, or IP precedence values in the traffic class; setting a specific DSCP or IP precedence value in the traffic class; or specifying the traffic bandwidth limitations and the action to take when the traffic is out of profile. Before a policy map can be effective, you must attach it to a port.

You create a class map by using the **class-map** global configuration command or the **class** policy-map configuration command. You should use the **class-map** command when the map is shared among many ports. When you enter the **class-map** command, the switch enters the class-map configuration mode. In this mode, you define the match criterion for the traffic by using the **match** class-map configuration command.

You create and name a policy map by using the **policy-map** global configuration command. When you enter this command, the switch enters the policy-map configuration mode. In this mode, you specify the actions to take on a specific traffic class by using the **class**, **trust**, or **set** policy-map configuration and policy-map class configuration commands.

The policy map can contain the **police** and **police aggregate** policy-map class configuration commands, which define the policer, the bandwidth limitations of the traffic, and the action to take if the limits are exceeded.

To enable the policy map, you attach it to a port by using the **service-policy** interface configuration command.

For more information, see the “[Policing and Marking](#)” section on page 28-8. For configuration information, see the “[Configuring a QoS Policy](#)” section on page 28-40.

Policing and Marking

After a packet is classified and has a DSCP-based or CoS-based QoS label assigned to it, the policing and marking process can begin as shown in [Figure 28-4](#).

Policing involves creating a policer that specifies the bandwidth limits for the traffic. Packets that exceed the limits are *out of profile* or *nonconforming*. Each policer decides on a packet-by-packet basis whether the packet is in or out of profile and specifies the actions on the packet. These actions, carried out by the marker, include passing through the packet without modification, dropping the packet, or modifying (marking down) the assigned DSCP of the packet and allowing the packet to pass through. The configurable policed-DSCP map provides the packet with a new DSCP-based QoS label. For information on the policed-DSCP map, see the “[Mapping Tables](#)” section on page 28-11. Marked-down packets use the same queues as the original QoS label to prevent packets in a flow from getting out of order.



Note

All traffic, regardless of whether it is bridged or routed, is subjected to a policer, if one is configured. As a result, bridged packets might be dropped or might have their DSCP or CoS fields modified when they are policed and marked.

You can configure policing on a physical port. For more information about configuring policing on physical ports, see the “[Policing on Physical Ports](#)” section on page 28-9.

After you configure the policy map and policing actions, attach the policy to an ingress port by using the **service-policy** interface configuration command. For configuration information, see the “[Classifying, Policing, and Marking Traffic on Physical Ports by Using Policy Maps](#)” section on page 28-46 and the “[Classifying, Policing, and Marking Traffic by Using Aggregate Policers](#)” section on page 28-49.

Policing on Physical Ports

In policy maps on physical ports, you can create these types of policers:

- Individual—QoS applies the bandwidth limits specified in the policer separately to each matched traffic class. You configure this type of policer within a policy map by using the **police** policy-map class configuration command.
- Aggregate—QoS applies the bandwidth limits specified in an aggregate policer cumulatively to all matched traffic flows. You configure this type of policer by specifying the aggregate policer name within a policy map by using the **police aggregate** policy-map class configuration command. You specify the bandwidth limits of the policer by using the **mls qos aggregate-policer** global configuration command. In this way, the aggregate policer is shared by multiple classes of traffic within a policy map.

Policing uses a token-bucket algorithm. As each frame is received by the switch, a token is added to the bucket. The bucket has a hole in it and leaks at a rate that you specify as the average traffic rate in bits per second. Each time a token is added to the bucket, the switch verifies that there is enough room in the bucket. If there is not enough room, the packet is marked as nonconforming, and the specified policer action is taken (dropped or marked down).

How quickly the bucket fills is a function of the bucket depth (burst-byte), the rate at which the tokens are removed (rate-b/s), and the duration of the burst above the average rate. The size of the bucket imposes an upper limit on the burst length and limits the number of frames that can be transmitted back-to-back. If the burst is short, the bucket does not overflow, and no action is taken against the traffic flow. However, if a burst is long and at a higher rate, the bucket overflows, and the policing actions are taken against the frames in that burst.

You configure the bucket depth (the maximum burst that is tolerated before the bucket overflows) by using the *burst-byte* option of the **police** policy-map class configuration command or the **mls qos aggregate-policer** global configuration command. You configure how fast (the average rate) that the tokens are removed from the bucket by using the *rate-bps* option of the **police** policy-map class configuration command or the **mls qos aggregate-policer** global configuration command.

Figure 28-4 shows the policing and marking process.

Figure 28-4 Policing and Marking Flowchart on Physical Ports

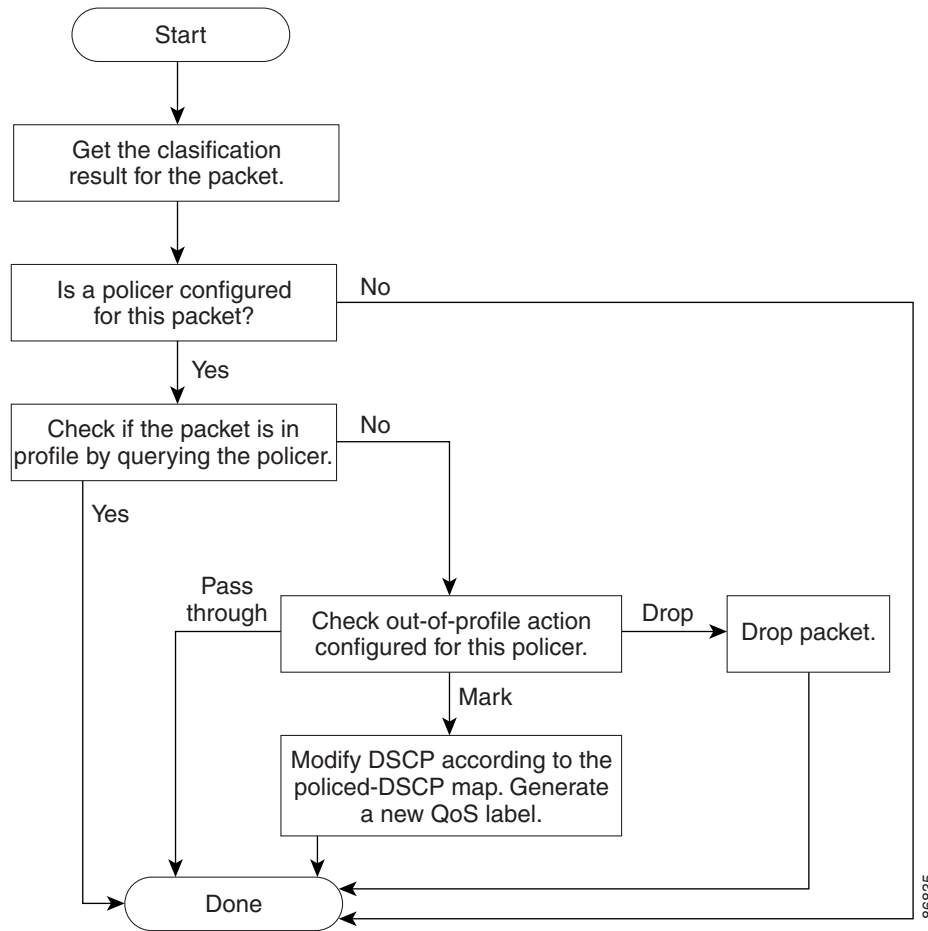

Mapping Tables

During QoS processing, the switch represents the priority of all traffic (including non-IP traffic) with an QoS label based on the DSCP or CoS value from the classification stage:

- During classification, QoS uses configurable mapping tables to derive a corresponding DSCP or CoS value from a received CoS, DSCP, or IP precedence value. These maps include the CoS-to-DSCP map and the IP-precedence-to-DSCP map. You configure these maps by using the **mls qos map cos-dscp** and the **mls qos map ip-prec-dscp** global configuration commands.

On an ingress port configured in the DSCP-trusted state, if the DSCP values are different between the QoS domains, you can apply the configurable DSCP-to-DSCP-mutation map to the port that is on the boundary between the two QoS domains. You configure this map by using the **mls qos map dscp-mutation** global configuration command.

- During policing, QoS can assign another DSCP value to an IP or a non-IP packet (if the packet is out of profile and the policer specifies a marked-down value). This configurable map is called the policed-DSCP map. You configure this map by using the **mls qos map policed-dscp** global configuration command.
- Before the traffic reaches the scheduling stage, QoS stores the packet in an ingress and an egress queue according to the QoS label. The QoS label is based on the DSCP or the CoS value in the packet and selects the queue through the DSCP input and output queue threshold maps or through the CoS input and output queue threshold maps. You configure these maps by using the **mls qos srr-queue {input | output} dscp-map** and the **mls qos srr-queue {input | output} cos-map** global configuration commands.

The CoS-to-DSCP, DSCP-to-CoS, and the IP-precedence-to-DSCP maps have default values that might or might not be appropriate for your network.

The default DSCP-to-DSCP-mutation map and the default policed-DSCP map are null maps; they map an incoming DSCP value to the same DSCP value. The DSCP-to-DSCP-mutation map is the only map you apply to a specific port. All other maps apply to the entire switch.

For configuration information, see the [“Configuring DSCP Maps” section on page 28-51](#).

For information about the DSCP and CoS input queue threshold maps, see the [“Queueing and Scheduling on Ingress Queues” section on page 28-14](#). For information about the DSCP and CoS output queue threshold maps, see the [“Queueing and Scheduling on Egress Queues” section on page 28-16](#).

Queueing and Scheduling Overview

The switch has queues at specific points to help prevent congestion as shown in [Figure 28-5](#).

Figure 28-5 Ingress and Egress Queue Location

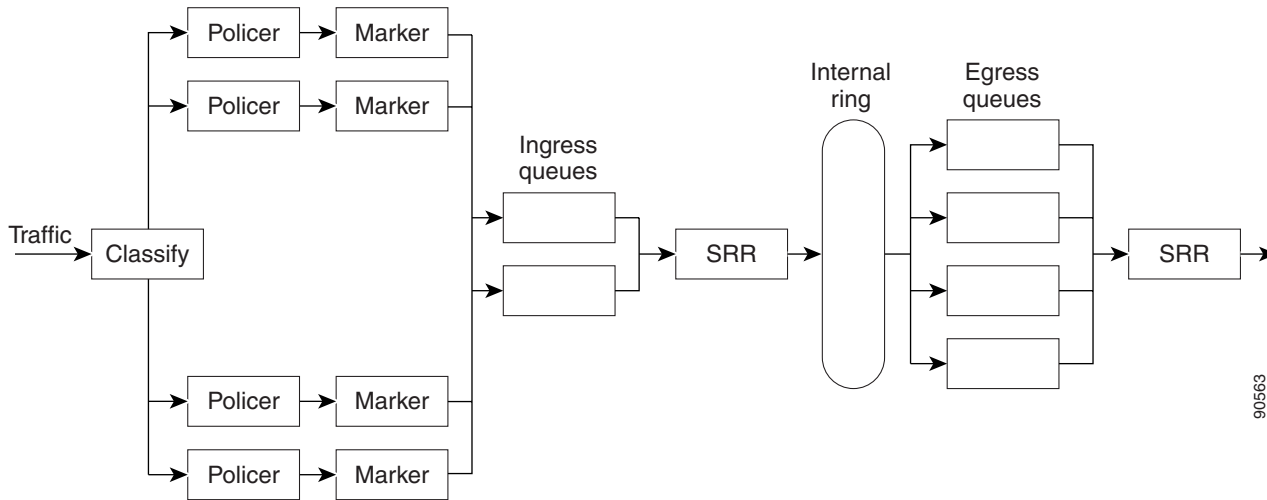

90563

Because the total inbound bandwidth of all ports can exceed the bandwidth of the internal ring, ingress queues are located after the packet is classified, policed, and marked and before packets are forwarded into the switch fabric. Because multiple ingress ports can simultaneously send packets to an egress port and cause congestion, outbound queues are located after the internal ring.

Weighted Tail Drop

Both the ingress and egress queues use an enhanced version of the tail-drop congestion-avoidance mechanism called weighted tail drop (WTD). WTD is implemented on queues to manage the queue lengths and to provide drop precedences for different traffic classifications.

As a frame is enqueued to a particular queue, WTD uses the frame’s assigned QoS label to subject it to different thresholds. If the threshold is exceeded for that QoS label (the space available in the destination queue is less than the size of the frame), the switch drops the frame.

[Figure 28-6](#) shows an example of WTD operating on a queue whose size is 1000 frames. Three drop percentages are configured: 40 percent (400 frames), 60 percent (600 frames), and 100 percent (1000 frames). These percentages mean that up to 400 frames can be queued at the 40-percent threshold, up to 600 frames at the 60-percent threshold, and up to 1000 frames at the 100-percent threshold.

In this example, CoS values 6 and 7 have a greater importance than the other CoS values, and they are assigned to the 100-percent drop threshold (queue-full state). CoS values 4 and 5 are assigned to the 60-percent threshold, and CoS values 0 to 3 are assigned to the 40-percent threshold.

Suppose the queue is already filled with 600 frames, and a new frame arrives. It contains CoS values 4 and 5 and is subjected to the 60-percent threshold. If this frame is added to the queue, the threshold will be exceeded, so the switch drops it.

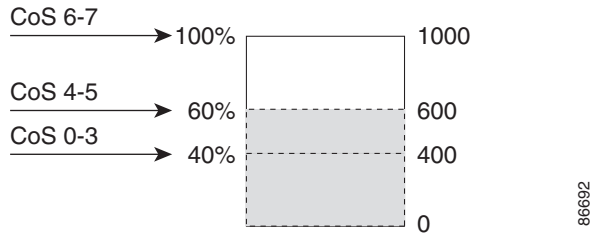
Figure 28-6 WTD and Queue Operation

For more information, see the [“Mapping DSCP or CoS Values to an Ingress Queue and Setting WTD Thresholds”](#) section on page 28-58, the [“Allocating Buffer Space to and Setting WTD Thresholds for an Egress Queue-Set”](#) section on page 28-62, and the [“Mapping DSCP or CoS Values to an Egress Queue and to a Threshold ID”](#) section on page 28-65.

SRR Shaping and Sharing

Both the ingress and egress queues are serviced by SRR, which controls the rate at which packets are sent. On the ingress queues, SRR sends packets to the internal ring. On the egress queues, SRR sends packets to the egress port.

You can configure SRR on egress queues for sharing or for shaping. However, for ingress queues, sharing is the default mode, and it is the only mode supported.

In shaped mode, the egress queues are guaranteed a percentage of the bandwidth, and they are rate-limited to that amount. Shaped traffic does not use more than the allocated bandwidth even if the link is idle. Shaping provides a more even flow of traffic over time and reduces the peaks and valleys of bursty traffic. With shaping, the absolute value of each weight is used to compute the bandwidth available for the queues.

In shared mode, the queues share the bandwidth among them according to the configured weights. The bandwidth is guaranteed at this level but not limited to it. For example, if a queue is empty and no longer requires a share of the link, the remaining queues can expand into the unused bandwidth and share it among them. With sharing, the ratio of the weights controls the frequency of dequeuing; the absolute values are meaningless.

For more information, see the [“Allocating Bandwidth Between the Ingress Queues”](#) section on page 28-60, the [“Configuring SRR Shaped Weights on Egress Queues”](#) section on page 28-66, and the [“Configuring SRR Shared Weights on Egress Queues”](#) section on page 28-67.

Queueing and Scheduling on Ingress Queues

Figure 28-7 shows the queueing and scheduling flowchart for ingress ports.

Figure 28-7 Queueing and Scheduling Flowchart for Ingress Ports

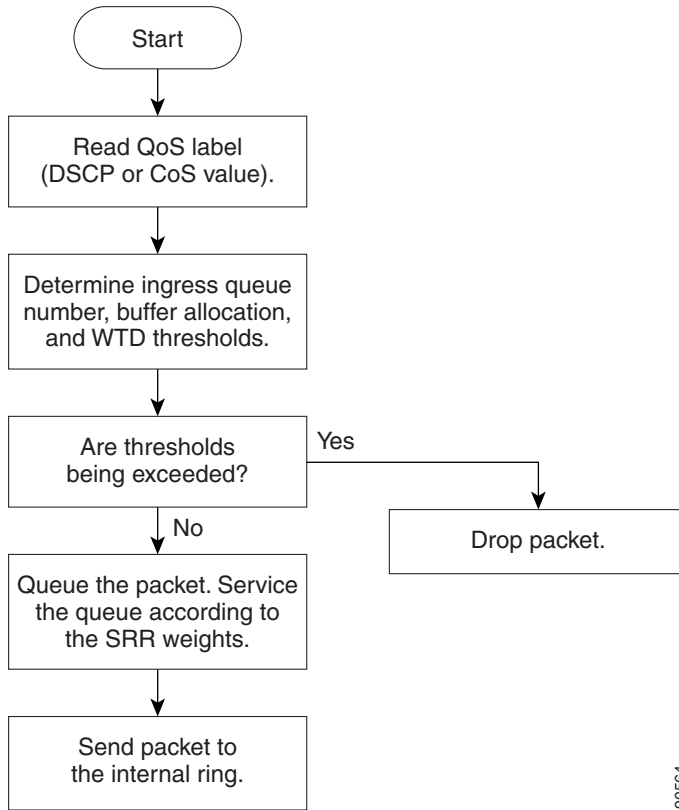

Note

SRR services the priority queue for its configured share before servicing the other queue.

The switch supports two configurable ingress queues, which are serviced by SRR in shared mode only. Table 28-1 describes the queues.

Table 28-1 Ingress Queue Types

Queue Type ¹	Function
Normal	User traffic that is considered to be normal priority. You can configure three different thresholds to differentiate among the flows. You can use the mls qos srr-queue input threshold , the mls qos srr-queue input dscp-map , and the mls qos srr-queue input cos-map global configuration commands.
Expedite	High-priority user traffic such as differentiated services (DF) expedited forwarding or voice traffic. You can configure the bandwidth required for this traffic as a percentage of the total traffic by using the mls qos srr-queue input priority-queue global configuration command. The expedite queue has guaranteed bandwidth.

1. The switch uses two nonconfigurable queues for traffic that is essential for proper network operation.

You assign each packet that flows through the switch to a queue and to a threshold. Specifically, you map DSCP or CoS values to an ingress queue and map DSCP or CoS values to a threshold ID. You use the **mls qos srr-queue input dscp-map queue** *queue-id* {*dscp1...dscp8* | **threshold** *threshold-id* *dscp1...dscp8*} or the **mls qos srr-queue input cos-map queue** *queue-id* {*cos1...cos8* | **threshold** *threshold-id* *cos1...cos8*} global configuration command. You can display the DSCP input queue threshold map and the CoS input queue threshold map by using the **show mls qos maps** privileged EXEC command.

WTD Thresholds

The queues use WTD to support distinct drop percentages for different traffic classes. Each queue has three drop thresholds: two configurable (*explicit*) WTD thresholds and one nonconfigurable (*implicit*) threshold preset to the queue-full state. You assign the two explicit WTD threshold percentages for threshold ID 1 and ID 2 to the ingress queues by using the **mls qos srr-queue input threshold** *queue-id* *threshold-percentagel* *threshold-percentagel2* global configuration command. Each threshold value is a percentage of the total number of allocated buffers for the queue. The drop threshold for threshold ID 3 is preset to the queue-full state, and you cannot modify it. For more information about how WTD works, see the “[Weighted Tail Drop](#)” section on page 28-12.

Buffer and Bandwidth Allocation

You define the ratio (allocate the amount of space) with which to divide the ingress buffers between the two queues by using the **mls qos srr-queue input buffers** *percentage1* *percentage2* global configuration command. The buffer allocation together with the bandwidth allocation control how much data can be buffered and sent before packets are dropped. You allocate bandwidth as a percentage by using the **mls qos srr-queue input bandwidth** *weight1* *weight2* global configuration command. The ratio of the weights is the ratio of the frequency in which the SRR scheduler sends packets from each queue.

Priority Queueing

You can configure one ingress queue as the priority queue by using the **mls qos srr-queue input priority-queue** *queue-id* **bandwidth** *weight* global configuration command. The priority queue should be used for traffic (such as voice) that requires guaranteed delivery because this queue is guaranteed part of the bandwidth regardless of the load on the internal ring.

SRR services the priority queue for its configured weight as specified by the **bandwidth** keyword in the **mls qos srr-queue input priority-queue** *queue-id* **bandwidth** *weight* global configuration command. Then, SRR shares the remaining bandwidth with both ingress queues and services them as specified by the weights configured with the **mls qos srr-queue input bandwidth** *weight1* *weight2* global configuration command.

You can combine the commands described in this section to prioritize traffic by placing packets with particular DSCPs or CoSs into certain queues, by allocating a large queue size or by servicing the queue more frequently, and by adjusting queue thresholds so that packets with lower priorities are dropped. For configuration information, see the “[Configuring Ingress Queue Characteristics](#)” section on page 28-57.

Queueing and Scheduling on Egress Queues

Figure 28-8 shows the queueing and scheduling flowchart for egress ports.



Note

If the expedite queue is enabled, SRR services it until it is empty before servicing the other three queues.

Figure 28-8 Queueing and Scheduling Flowchart for Egress Ports

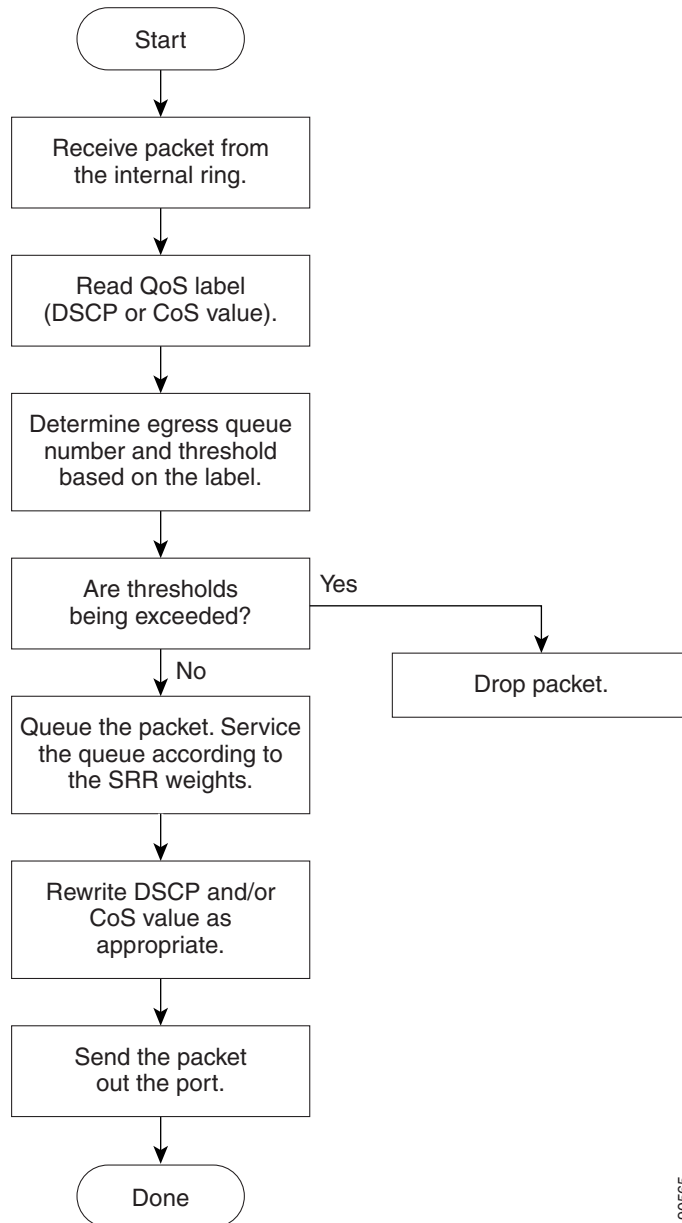

90565

Each port supports four egress queues, one of which (queue 1) can be the egress expedite queue. These queues are assigned to a queue-set. All traffic exiting the switch flows through one of these four queues and is subjected to a threshold based on the QoS label assigned to the packet.

Figure 28-9 shows the egress queue buffer. The buffer space is divided between the common pool and the reserved pool. The switch uses a buffer allocation scheme to reserve a minimum amount of buffers for each egress queue, to prevent any queue or port from consuming all the buffers and depriving other queues, and to control whether to grant buffer space to a requesting queue. The switch detects whether the target queue has not consumed more buffers than its reserved amount (under-limit), whether it has consumed all of its maximum buffers (over limit), and whether the common pool is empty (no free buffers) or not empty (free buffers). If the queue is not over-limit, the switch can allocate buffer space from the reserved pool or from the common pool (if it is not empty). If there are no free buffers in the common pool or if the queue is over-limit, the switch drops the frame.

Figure 28-9 Egress Queue Buffer Allocation

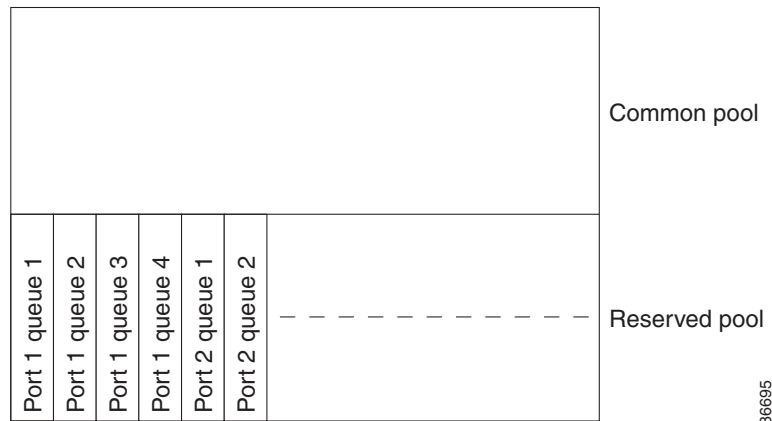

Buffer and Memory Allocation

You guarantee the availability of buffers, set drop thresholds, and configure the maximum memory allocation for a queue-set by using the **mls qos queue-set output *qset-id* threshold *queue-id* drop-threshold1 drop-threshold2 reserved-threshold maximum-threshold** global configuration command. Each threshold value is a percentage of the queue's allocated memory, which you specify by using the **mls qos queue-set output *qset-id* buffers *allocation1* ... *allocation4*** global configuration command. The sum of all the allocated buffers represents the reserved pool, and the remaining buffers are part of the common pool.

Through buffer allocation, you can ensure that high-priority traffic is buffered. For example, if the buffer space is 400, you can allocate 70 percent of it to queue 1 and 10 percent to queues 2 through 4. Queue 1 then has 280 buffers allocated to it, and queues 2 through 4 each have 40 buffers allocated to them.

You can guarantee that the allocated buffers are reserved for a specific queue in a queue-set. For example, if there are 100 buffers for a queue, you can reserve 50 percent (50 buffers). The switch returns the remaining 50 buffers to the common pool. You also can enable a queue in the full condition to obtain more buffers than are reserved for it by setting a maximum threshold. The switch can allocate the needed buffers from the common pool if the common pool is not empty.

WTD Thresholds

You can assign each packet that flows through the switch to a queue and to a threshold. Specifically, you map DSCP or CoS values to an egress queue and map DSCP or CoS values to a threshold ID. You use the **mls qos srr-queue output dscp-map queue *queue-id* {*dscp1*...*dscp8* | **threshold** *threshold-id* *dscp1*...*dscp8*}** or the **mls qos srr-queue output cos-map queue *queue-id* {*cos1*...*cos8* | **threshold****

`threshold-id cos1...cos8}` global configuration command. You can display the DSCP output queue threshold map and the CoS output queue threshold map by using the **show mls qos maps** privileged EXEC command.

The queues use WTD to support distinct drop percentages for different traffic classes. Each queue has three drop thresholds: two configurable (*explicit*) WTD thresholds and one nonconfigurable (*implicit*) threshold preset to the queue-full state. You assign the two WTD threshold percentages for threshold ID 1 and ID 2. The drop threshold for threshold ID 3 is preset to the queue-full state, and you cannot modify it. For more information about how WTD works, see the “[Weighted Tail Drop](#)” section on [page 28-12](#).

Shaped or Shared Mode

SRR services each queue-set in shared or shaped mode. You map a port to a queue-set by using the **queue-set** `qset-id` interface configuration command. You assign shared or shaped weights to the port by using the **srr-queue bandwidth share** `weight1 weight2 weight3 weight4` or the **srr-queue bandwidth shape** `weight1 weight2 weight3 weight4` interface configuration command. For an explanation of the differences between shaping and sharing, see the “[SRR Shaping and Sharing](#)” section on [page 28-13](#).

The buffer allocation together with the SRR weight ratios control how much data can be buffered and sent before packets are dropped. The weight ratio is the ratio of the frequency in which the SRR scheduler sends packets from each queue.

All four queues participate in the SRR unless the expedite queue is enabled, in which case the first bandwidth weight is ignored and is not used in the ratio calculation. The expedite queue is a priority queue, and it is serviced until empty before the other queues are serviced. You enable the expedite queue by using the **priority-queue out** interface configuration command.

You can combine the commands described in this section to prioritize traffic by placing packets with particular DSCPs or CoSs into certain queues, by allocating a large queue size or by servicing the queue more frequently, and by adjusting queue thresholds so that packets with lower priorities are dropped. For configuration information, see the “[Configuring Egress Queue Characteristics](#)” section on [page 28-62](#).



Note

The egress queue default settings are suitable for most situations. You should change them only when you have a thorough understanding of the egress queues and if these settings do not meet your QoS solution.

Packet Modification

A packet is classified, policed, and queued to provide QoS. Packet modifications can occur during this process:

- For IP and non-IP packets, classification involves assigning a QoS label to a packet based on the DSCP or CoS of the received packet. However, the packet is not modified at this stage; only an indication of the assigned DSCP or CoS value is carried along. The reason for this is that QoS classification and forwarding lookups occur in parallel, and it is possible that the packet is forwarded with its original DSCP to the CPU where it is again processed through software.
- During policing, IP and non-IP packets can have another DSCP assigned to them (if they are out of profile and the policer specifies a markdown DSCP). Once again, the DSCP in the packet is not modified, but an indication of the marked-down value is carried along. For IP packets, the packet modification occurs at a later stage; for non-IP packets the DSCP is converted to CoS and used for queuing and scheduling decisions.

- Depending on the QoS label assigned to a frame and the mutation chosen, the DSCP and CoS values of the frame are rewritten. If you do not configure the mutation map and if you configure the port to trust the DSCP of the incoming frame, the DSCP value in the frame is not changed, but the CoS is rewritten according to the DSCP-to-CoS map. If you configure the port to trust the CoS of the incoming frame and it is an IP packet, the CoS value in the frame is not changed, but the DSCP might be changed according to the CoS-to-DSCP map.

The input mutation causes the DSCP to be rewritten depending on the new value of DSCP chosen. The set action in a policy map also causes the DSCP to be rewritten.

Configuring Auto-QoS

You can use the auto-QoS feature to simplify the deployment of existing QoS features. Auto-QoS makes assumptions about the network design, and as a result, the switch can prioritize different traffic flows and appropriately use the ingress and egress queues instead of using the default QoS behavior. (The default is that QoS is disabled. The switch then offers best-effort service to each packet, regardless of the packet contents or size, and sends it from a single queue.)

When you enable auto-QoS, it automatically classifies traffic based on the traffic type and ingress packet label. The switch uses the resulting classification to choose the appropriate egress queue.

You use auto-QoS commands to identify ports connected to Cisco IP Phones and to devices running the Cisco SoftPhone application. You also use the commands to identify ports that receive trusted traffic through an uplink. Auto-QoS then performs these functions:

- Detects the presence or absence of Cisco IP Phones
- Configures QoS classification
- Configures egress queues

These sections contain this configuration information:

- [Generated Auto-QoS Configuration, page 28-20](#)
- [Effects of Auto-QoS on the Configuration, page 28-24](#)
- [Auto-QoS Configuration Guidelines, page 28-25](#)
- [Enabling Auto-QoS for VoIP, page 28-25](#)
- [Auto-QoS Configuration Example, page 28-27](#)

Generated Auto-QoS Configuration

By default, auto-QoS is disabled on all ports.

When auto-QoS is enabled, it uses the ingress packet label to categorize traffic, to assign packet labels, and to configure the ingress and egress queues as shown in [Table 28-2](#).

Table 28-2 Traffic Types, Packet Labels, and Queues

	VoIP ¹ Data Traffic	VoIP Control Traffic	Routing Protocol Traffic	STP BPDU Traffic	Real-Time Video Traffic	All Other Traffic
DSCP	46	24, 26	48	56	34	–
CoS	5	3	6	7	4	–
CoS-to-Ingress Queue Map	2, 3, 4, 5, 6, 7 (queue 2)					0, 1 (queue 1)
CoS-to-Egress Queue Map	5 (queue 1)	3, 6, 7 (queue 2)			4 (queue 3)	2 (queue 3) 0, 1 (queue 4)

1. VoIP = voice over IP

[Table 28-3](#) shows the generated auto-QoS configuration for the ingress queues.

Table 28-3 Auto-QoS Configuration for the Ingress Queues

Ingress Queue	Queue Number	CoS-to-Queue Map	Queue Weight (Bandwidth)	Queue (Buffer) Size
SRR shared	1	0, 1	81 percent	67 percent
Priority	2	2, 3, 4, 5, 6, 7	19 percent	33 percent

[Table 28-4](#) shows the generated auto-QoS configuration for the egress queues.

Table 28-4 Auto-QoS Configuration for the Egress Queues

Egress Queue	Queue Number	CoS-to-Queue Map	Queue Weight (Bandwidth)	Queue (Buffer) Size for Gigabit-Capable Ports	Queue (Buffer) Size for 10/100 Ethernet Ports
Priority	1	5	up to 100 percent	16 percent	10 percent
SRR shared	2	3, 6, 7	10 percent	6 percent	10 percent
SRR shared	3	2, 4	60 percent	17 percent	26 percent
SRR shared	4	0, 1	20 percent	61 percent	54 percent

When you enable the auto-QoS feature on the first port, these automatic actions occur:

- QoS is globally enabled (**mls qos** global configuration command), and other global configuration commands are added.
- When you enter the **auto qos voip cisco-phone** interface configuration command on a port at the edge of the network that is connected to a Cisco IP Phone, the switch enables the trusted boundary feature. The switch uses the Cisco Discovery Protocol (CDP) to detect the presence or absence of a Cisco IP Phone. When a Cisco IP Phone is detected, the ingress classification on the port is set to

trust the QoS label received in the packet. The switch also uses policing to determine whether a packet is in or out of profile and to specify the action on the packet. If the packet does not have a DSCP value of 24, 26, or 46 or is out of profile, the switch changes the DSCP value to 0. When a Cisco IP Phone is absent, the ingress classification is set to not trust the QoS label in the packet. The switch configures ingress and egress queues on the port according to the settings in [Table 28-3](#) and [Table 28-4](#). The policing is applied to those traffic matching the policy-map classification before the switch enables the trust boundary feature.

- When you enter the **auto qos voip cisco-softphone** interface configuration command on a port at the edge of the network that is connected to a device running the Cisco SoftPhone, the switch uses policing to determine whether a packet is in or out of profile and to specify the action on the packet. If the packet does not have a DSCP value of 24, 26, or 46 or is out of profile, the switch changes the DSCP value to 0. The switch configures ingress and egress queues on the port according to the settings in [Table 28-3](#) and [Table 28-4](#).
- When you enter the **auto qos voip trust** interface configuration command on a port connected to the interior of the network, the switch trusts the CoS value for nonrouted ports in ingress packets (the assumption is that traffic has already been classified by other edge devices). The switch configures the ingress and egress queues on the port according to the settings in [Table 28-3](#) and [Table 28-4](#).

For information about the trusted boundary feature, see the “[Configuring a Trusted Boundary to Ensure Port Security](#)” section on page 28-36.

When you enable auto-QoS by using the **auto qos voip cisco-phone**, the **auto qos voip cisco-softphone**, or the **auto qos voip trust** interface configuration command, the switch automatically generates a QoS configuration based on the traffic type and ingress packet label and applies the commands listed in [Table 28-5](#) to the port.

Table 28-5 Generated Auto-QoS Configuration

Description	Automatically Generated Command
The switch automatically enables standard QoS and configures the CoS-to-DSCP map (maps CoS values in incoming packets to a DSCP value).	<pre>Switch(config)# mls qos Switch(config)# mls qos map cos-dscp 0 8 16 26 32 46 48 56</pre>
The switch automatically maps CoS values to an ingress queue and to a threshold ID.	<pre>Switch(config)# no mls qos srr-queue input cos-map Switch(config)# mls qos srr-queue input cos-map queue 1 threshold 3 0 Switch(config)# mls qos srr-queue input cos-map queue 1 threshold 2 1 Switch(config)# mls qos srr-queue input cos-map queue 2 threshold 1 2 Switch(config)# mls qos srr-queue input cos-map queue 2 threshold 2 4 6 7 Switch(config)# mls qos srr-queue input cos-map queue 2 threshold 3 3 5</pre>
The switch automatically maps CoS values to an egress queue and to a threshold ID.	<pre>Switch(config)# no mls qos srr-queue output cos-map Switch(config)# mls qos srr-queue output cos-map queue 1 threshold 3 5 Switch(config)# mls qos srr-queue output cos-map queue 2 threshold 3 3 6 7 Switch(config)# mls qos srr-queue output cos-map queue 3 threshold 3 2 4 Switch(config)# mls qos srr-queue output cos-map queue 4 threshold 2 1 Switch(config)# mls qos srr-queue output cos-map queue 4 threshold 3 0</pre>

Table 28-5 Generated Auto-QoS Configuration (continued)

Description	Automatically Generated Command
The switch automatically maps DSCP values to an ingress queue and to a threshold ID.	<pre>Switch(config)# no mls qos srr-queue input dscp-map Switch(config)# mls qos srr-queue input dscp-map queue 1 threshold 2 9 10 11 12 13 14 15 Switch(config)# mls qos srr-queue input dscp-map queue 1 threshold 3 0 1 2 3 4 5 6 7 Switch(config)# mls qos srr-queue input dscp-map queue 1 threshold 3 32 Switch(config)# mls qos srr-queue input dscp-map queue 2 threshold 1 16 17 18 19 20 21 22 23 Switch(config)# mls qos srr-queue input dscp-map queue 2 threshold 2 33 34 35 36 37 38 39 48 Switch(config)# mls qos srr-queue input dscp-map queue 2 threshold 2 49 50 51 52 53 54 55 56 Switch(config)# mls qos srr-queue input dscp-map queue 2 threshold 2 57 58 59 60 61 62 63 Switch(config)# mls qos srr-queue input dscp-map queue 2 threshold 3 24 25 26 27 28 29 30 31 Switch(config)# mls qos srr-queue input dscp-map queue 2 threshold 3 40 41 42 43 44 45 46 47</pre>
The switch automatically maps DSCP values to an egress queue and to a threshold ID.	<pre>Switch(config)# no mls qos srr-queue output dscp-map Switch(config)# mls qos srr-queue output dscp-map queue 1 threshold 3 40 41 42 43 44 45 46 47 Switch(config)# mls qos srr-queue output dscp-map queue 2 threshold 3 24 25 26 27 28 29 30 31 Switch(config)# mls qos srr-queue output dscp-map queue 2 threshold 3 48 49 50 51 52 53 54 55 Switch(config)# mls qos srr-queue output dscp-map queue 2 threshold 3 56 57 58 59 60 61 62 63 Switch(config)# mls qos srr-queue output dscp-map queue 3 threshold 3 16 17 18 19 20 21 22 23 Switch(config)# mls qos srr-queue output dscp-map queue 3 threshold 3 32 33 34 35 36 37 38 39 Switch(config)# mls qos srr-queue output dscp-map queue 4 threshold 1 8 Switch(config)# mls qos srr-queue output dscp-map queue 4 threshold 2 9 10 11 12 13 14 15 Switch(config)# mls qos srr-queue output dscp-map queue 4 threshold 3 0 1 2 3 4 5 6 7</pre>
The switch automatically sets up the ingress queues, with queue 2 as the priority queue and queue 1 in shared mode. The switch also configures the bandwidth and buffer size for the ingress queues.	<pre>Switch(config)# no mls qos srr-queue input priority-queue 1 Switch(config)# no mls qos srr-queue input priority-queue 2 Switch(config)# mls qos srr-queue input bandwidth 90 10 Switch(config)# mls qos srr-queue input threshold 1 8 16 Switch(config)# mls qos srr-queue input threshold 2 34 66 Switch(config)# mls qos srr-queue input buffers 67 33</pre>

Table 28-5 Generated Auto-QoS Configuration (continued)

Description	Automatically Generated Command
The switch automatically configures the egress queue buffer sizes. It configures the bandwidth and the SRR mode (shaped or shared) on the egress queues mapped to the port.	<pre>Switch(config)# mls qos queue-set output 1 threshold 1 138 138 92 138 Switch(config)# mls qos queue-set output 1 threshold 2 138 138 92 400 Switch(config)# mls qos queue-set output 1 threshold 3 36 77 100 318 Switch(config)# mls qos queue-set output 1 threshold 4 20 50 67 400 Switch(config)# mls qos queue-set output 2 threshold 1 149 149 100 149 Switch(config)# mls qos queue-set output 2 threshold 2 118 118 100 235 Switch(config)# mls qos queue-set output 2 threshold 3 41 68 100 272 Switch(config)# mls qos queue-set output 2 threshold 4 42 72 100 242 Switch(config)# mls qos queue-set output 1 buffers 10 10 26 54 Switch(config)# mls qos queue-set output 2 buffers 16 6 17 61 Switch(config-if)# priority-que out Switch(config-if)# srr-queue bandwidth share 10 10 60 20</pre>
If you entered the auto qos voip trust command, the switch automatically sets the ingress classification to trust the CoS value received in the packet on a nonrouted port by using the mls qos trust cos command.	<pre>Switch(config-if)# mls qos trust cos Switch(config-if)# mls qos trust dscp</pre>
If you entered the auto qos voip cisco-phone command, the switch automatically enables the trusted boundary feature, which uses the CDP to detect the presence or absence of a Cisco IP Phone.	<pre>Switch(config-if)# mls qos trust device cisco-phone</pre>
If you entered the auto qos voip cisco-softphone command, the switch automatically creates class maps and policy maps.	<pre>Switch(config)# mls qos map policed-dscp 24 26 46 to 0 Switch(config)# class-map match-all AutoQoS-VoIP-RTP-Trust Switch(config-cmap)# match ip dscp ef Switch(config)# class-map match-all AutoQoS-VoIP-Control-Trust Switch(config-cmap)# match ip dscp cs3 af31 Switch(config)# policy-map AutoQoS-Police-SoftPhone Switch(config-pmap)# class AutoQoS-VoIP-RTP-Trust Switch(config-pmap-c)# set dscp ef Switch(config-pmap-c)# police 320000 8000 exceed-action policed-dscp-transmit Switch(config-pmap)# class AutoQoS-VoIP-Control-Trust Switch(config-pmap-c)# set dscp cs3 Switch(config-pmap-c)# police 32000 8000 exceed-action policed-dscp-transmit</pre>
After creating the class maps and policy maps, the switch automatically applies the policy map called <i>AutoQoS-Police-SoftPhone</i> to an ingress interface on which auto-QoS with the Cisco SoftPhone feature is enabled.	<pre>Switch(config-if)# service-policy input AutoQoS-Police-SoftPhone</pre>

Table 28-5 Generated Auto-QoS Configuration (continued)

Description	Automatically Generated Command
If you entered the auto qos voip cisco-phone command, the switch automatically creates class maps and policy maps.	<pre> Switch(config)# mls qos map policed-dscp 24 26 46 to 0 Switch(config)# class-map match-all AutoQoS-VoIP-RTP-Trust Switch(config-cmap)# match ip dscp ef Switch(config)# class-map match-all AutoQoS-VoIP-Control-Trust Switch(config-cmap)# match ip dscp cs3 af31 Switch(config)# policy-map AutoQoS-Police-CiscoPhone Switch(config-pmap)# class AutoQoS-VoIP-RTP-Trust Switch(config-pmap-c)# set dscp ef Switch(config-pmap-c)# police 320000 8000 exceed-action policed-dscp-transmit Switch(config-pmap)# class AutoQoS-VoIP-Control-Trust Switch(config-pmap-c)# set dscp cs3 Switch(config-pmap-c)# police 32000 8000 exceed-action policed-dscp-transmit </pre>
After creating the class maps and policy maps, the switch automatically applies the policy map named <i>AutoQoS-Police-CiscoPhone</i> to an ingress interface on which auto-QoS with the Cisco Phone feature is enabled.	<pre> Switch(config-if)# service-policy input AutoQoS-Police-CiscoPhone </pre>

Effects of Auto-QoS on the Configuration

When auto-QoS is enabled, the **auto qos voip** interface configuration command and the generated configuration are added to the running configuration.

The switch applies the auto-QoS-generated commands as if the commands were entered from the CLI. An existing user configuration can cause the application of the generated commands to fail or to be overridden by the generated commands. These actions occur without warning. If all the generated commands are successfully applied, any user-entered configuration that was not overridden remains in the running configuration. Any user-entered configuration that was overridden can be retrieved by reloading the switch without saving the current configuration to memory. If the generated commands fail to be applied, the previous running configuration is restored.

Auto-QoS Configuration Guidelines

Before configuring auto-QoS, you should be aware of this information:

- Auto-QoS configures the switch for VoIP with Cisco IP Phones on nonrouted and routed ports. Auto-QoS also configures the switch for VoIP with devices running the Cisco SoftPhone application.



Note When a device running Cisco SoftPhone is connected to a nonrouted or routed port, the switch supports only one Cisco SoftPhone application per port.

- Beginning with Cisco IOS Release 12.2(40)SE, Auto-QoS VoIP uses the **priority-queue** interface configuration command for an egress interface. You can also configure a policy-map and trust device on the same interface for Cisco IP phones.
- If the switch port was [configured by using the auto qos voip cisco-phone interface configuration command](#) in Cisco IOS Release 12.2(37)SE or earlier, the auto-QoS generated commands new to Cisco IOS Release 12.2(40)SE are not applied to the port. To have these commands automatically applied, you must remove and then reapply the configuration to the port.
- To take advantage of the auto-QoS defaults, you should enable auto-QoS before you configure other QoS commands. If necessary, you can fine-tune the QoS configuration, but we recommend that you do so only after the auto-QoS configuration is completed. For more information, see the [Effects of Auto-QoS on the Configuration](#), page 28-24.
- After auto-QoS is enabled, do not modify a policy map or aggregate policer that includes *AutoQoS* in its name. If you need to modify the policy map or aggregate policer, make a copy of it, and change the copied policy map or policer. To use this new policy map instead of the generated one, remove the generated policy map from the interface, and apply the new policy map to the interface.
- You can enable auto-QoS on static, dynamic-access, voice VLAN access, and trunk ports.
- By default, the CDP is enabled on all ports. For auto-QoS to function properly, do not disable the CDP.
- When enabling auto-QoS with a Cisco IP Phone on a routed port, you must assign a static IP address to the IP phone.
- This release supports only Cisco IP SoftPhone Version 1.3(3) or later.
- Connected devices must use Cisco Call Manager Version 4 or later.

Enabling Auto-QoS for VoIP

Beginning in privileged EXEC mode, follow these steps to enable auto-QoS for VoIP within a QoS domain:

	Command	Purpose
Step 1	configure terminal	Enter global configuration mode.
Step 2	interface <i>interface-id</i>	Specify the port that is connected to a Cisco IP Phone, the port that is connected to a device running the Cisco SoftPhone feature, or the uplink port that is connected to another trusted switch or router in the interior of the network, and enter interface configuration mode.

	Command	Purpose
Step 3	<code>auto qos voip { cisco-phone cisco-softphone trust }</code>	<p>Enable auto-QoS.</p> <p>The keywords have these meanings:</p> <ul style="list-style-type: none"> • cisco-phone—If the port is connected to a Cisco IP Phone, the QoS labels of incoming packets are trusted only when the telephone is detected. • cisco-softphone—The port is connected to device running the Cisco SoftPhone feature. • trust—The uplink port is connected to a trusted switch or router, and the VoIP traffic classification in the ingress packet is trusted.
Step 4	<code>end</code>	Return to privileged EXEC mode.
Step 5	<code>show auto qos interface interface-id</code>	<p>Verify your entries.</p> <p>This command displays the auto-QoS command on the interface on which auto-QoS was enabled. You can use the show running-config privileged EXEC command to display the auto-QoS configuration and the user modifications.</p>

To display the QoS commands that are automatically generated when auto-QoS is enabled or disabled, enter the **debug auto qos** privileged EXEC command *before* enabling auto-QoS. For more information, see the **debug autoqos** command in the command reference for this release.

To disable auto-QoS on a port, use the **no auto qos voip** interface configuration command. Only the auto-QoS-generated interface configuration commands for this port are removed. If this is the last port on which auto-QoS is enabled and you enter the **no auto qos voip** command, auto-QoS is considered disabled even though the auto-QoS-generated global configuration commands remain (to avoid disrupting traffic on other ports affected by the global configuration).

You can use the **no mls qos** global configuration command to disable the auto-QoS-generated global configuration commands. With QoS disabled, there is no concept of trusted or untrusted ports because the packets are not modified (the CoS, DSCP, and IP precedence values in the packet are not changed). Traffic is switched in pass-through mode (packets are switched without any rewrites and classified as best effort without any policing).

This example shows how to enable auto-QoS and to trust the QoS labels received in incoming packets when the switch or router connected to a port is a trusted device:

```
Switch(config)# interface gigabitethernet0/1
Switch(config-if)# auto qos voip trust
```

Auto-QoS Configuration Example

This section describes how you could implement auto-QoS in a network, as shown in [Figure 28-10](#). For optimum QoS performance, enable auto-QoS on all the devices in the network.

Figure 28-10 Auto-QoS Configuration Example Network

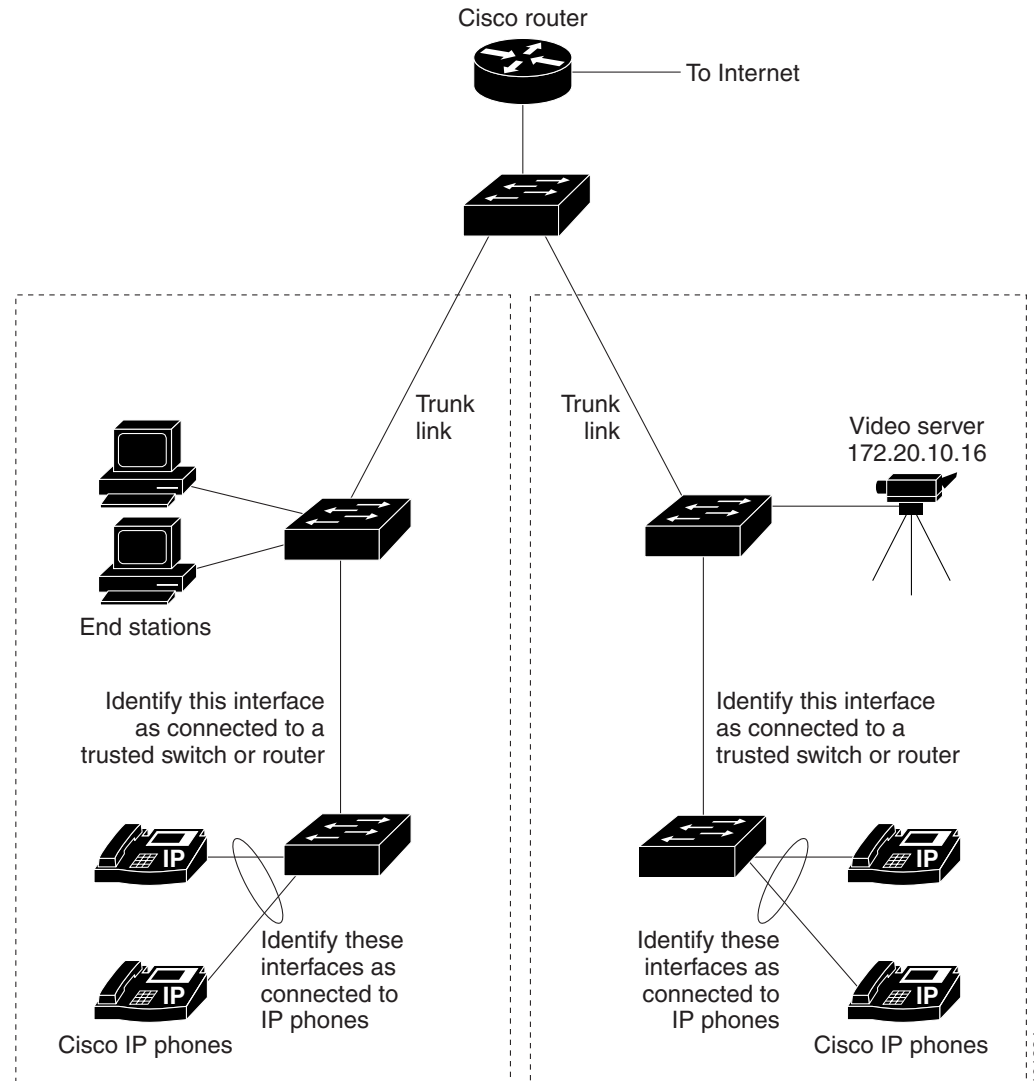

[Figure 28-10](#) shows a network in which the VoIP traffic is prioritized over all other traffic. Auto-QoS is enabled on the switches in the wiring closets at the edge of the QoS domain.

**Note**

You should not configure any standard QoS commands before entering the auto-QoS commands. You can fine-tune the QoS configuration, but we recommend that you do so only after the auto-QoS configuration is completed.

Beginning in privileged EXEC mode, follow these steps to configure the switch at the edge of the QoS domain to prioritize the VoIP traffic over all other traffic:

	Command	Purpose
Step 1	debug auto qos	Enable debugging for auto-QoS. When debugging is enabled, the switch displays the QoS configuration that is automatically generated when auto-QoS is enabled.
Step 2	configure terminal	Enter global configuration mode.
Step 3	cdp enable	Enable CDP globally. By default, it is enabled.
Step 4	interface <i>interface-id</i>	Specify the switch port connected to the Cisco IP Phone, and enter interface configuration mode.
Step 5	auto qos voip cisco-phone	Enable auto-QoS on the port, and specify that the port is connected to a Cisco IP Phone. The QoS labels of incoming packets are trusted only when the Cisco IP Phone is detected.
Step 6	exit	Return to global configuration mode.
Step 7		Repeat Steps 4 to 6 for as many ports as are connected to the Cisco IP Phone.
Step 8	interface <i>interface-id</i>	Specify the switch port identified as connected to a trusted switch or router, and enter interface configuration mode. See Figure 28-10 .
Step 9	auto qos voip trust	Enable auto-QoS on the port, and specify that the port is connected to a trusted router or switch.
Step 10	end	Return to privileged EXEC mode.
Step 11	show auto qos	Verify your entries. This command displays the auto-QoS command on the interface on which auto-QoS was enabled. You can use the show running-config privileged EXEC command to display the auto-QoS configuration and the user modifications. For information about the QoS configuration that might be affected by auto-QoS, see the “Displaying Auto-QoS Information” section on page 26-12.
Step 12	copy running-config startup-config	Save the auto qos voip interface configuration commands and the generated auto-QoS configuration in the configuration file.

Displaying Auto-QoS Information

To display the initial auto-QoS configuration, use the **show auto qos [interface *interface-id*]** privileged EXEC command. To display any user changes to that configuration, use the **show running-config** privileged EXEC command. You can compare the **show auto qos** and the **show running-config** command output to identify the user-defined QoS settings.

To display information about the QoS configuration that might be affected by auto-QoS, use one of these commands:

- **show mls qos**
- **show mls qos maps cos-dscp**
- **show mls qos interface *interface-id* [buffers | queueing]**
- **show mls qos maps [cos-dscp | cos-input-q | cos-output-q | dscp-cos | dscp-input-q | dscp-output-q]**
- **show mls qos input-queue**
- **show running-config**

For more information about these commands, see the command reference for this release.

Configuring Standard QoS

Before configuring standard QoS, you must have a thorough understanding of these items:

- The types of applications used and the traffic patterns on your network.
- Traffic characteristics and needs of your network. Is the traffic bursty? Do you need to reserve bandwidth for voice and video streams?
- Bandwidth requirements and speed of the network.
- Location of congestion points in the network.

These sections contain this configuration information:

- [Default Standard QoS Configuration, page 28-30](#)
- [Standard QoS Configuration Guidelines, page 28-32](#)
- [Enabling QoS Globally, page 28-33](#) (required)
- [Configuring Classification Using Port Trust States, page 28-34](#) (required)
- [Configuring a QoS Policy, page 28-40](#) (required)
- [Configuring DSCP Maps, page 28-51](#) (optional, unless you need to use the DSCP-to-DSCP-mutation map or the policed-DSCP map)
- [Configuring Ingress Queue Characteristics, page 28-57](#) (optional)
- [Configuring Egress Queue Characteristics, page 28-62](#) (optional)

Default Standard QoS Configuration

QoS is disabled. There is no concept of trusted or untrusted ports because the packets are not modified (the CoS, DSCP, and IP precedence values in the packet are not changed). Traffic is switched in pass-through mode (packets are switched without any rewrites and classified as best effort without any policing).

When QoS is enabled with the **mls qos** global configuration command and all other QoS settings are at their defaults, traffic is classified as best effort (the DSCP and CoS value is set to 0) without any policing. No policy maps are configured. The default port trust state on all ports is untrusted. The default ingress and egress queue settings are described in the “[Default Ingress Queue Configuration](#)” section on page 28-30 and the “[Default Egress Queue Configuration](#)” section on page 28-31.

Default Ingress Queue Configuration

Table 28-6 shows the default ingress queue configuration when QoS is enabled.

Table 28-6 Default Ingress Queue Configuration

Feature	Queue 1	Queue 2
Buffer allocation	90 percent	10 percent
Bandwidth allocation ¹	4	4
Priority queue bandwidth ²	0	10
WTD drop threshold 1	100 percent	100 percent
WTD drop threshold 2	100 percent	100 percent

1. The bandwidth is equally shared between the queues. SRR sends packets in shared mode only.
2. Queue 2 is the priority queue. SRR services the priority queue for its configured share before servicing the other queue.

Table 28-7 shows the default CoS input queue threshold map when QoS is enabled.

Table 28-7 Default CoS Input Queue Threshold Map

CoS Value	Queue ID–Threshold ID
0–4	1–1
5	2–1
6, 7	1–1

Table 28-8 shows the default DSCP input queue threshold map when QoS is enabled.

Table 28-8 Default DSCP Input Queue Threshold Map

DSCP Value	Queue ID–Threshold ID
0–39	1–1
40–47	2–1
48–63	1–1

Default Egress Queue Configuration

Table 28-9 shows the default egress queue configuration for each queue-set when QoS is enabled. All ports are mapped to queue-set 1. The port bandwidth limit is set to 100 percent and rate unlimited.

Table 28-9 *Default Egress Queue Configuration*

Feature	Queue 1	Queue 2	Queue 3	Queue 4
Buffer allocation	25 percent	25 percent	25 percent	25 percent
WTD drop threshold 1	100 percent	200 percent	100 percent	100 percent
WTD drop threshold 2	100 percent	200 percent	100 percent	100 percent
Reserved threshold	50 percent	50 percent	50 percent	50 percent
Maximum threshold	400 percent	400 percent	400 percent	400 percent
SRR shaped weights (absolute) ¹	25	0	0	0
SRR shared weights ²	25	25	25	25

1. A shaped weight of zero means that this queue is operating in shared mode.
2. One quarter of the bandwidth is allocated to each queue.

Table 28-10 shows the default CoS output queue threshold map when QoS is enabled.

Table 28-10 *Default CoS Output Queue Threshold Map*

CoS Value	Queue ID–Threshold ID
0, 1	2–1
2, 3	3–1
4	4–1
5	1–1
6, 7	4–1

Table 28-11 shows the default DSCP output queue threshold map when QoS is enabled.

Table 28-11 *Default DSCP Output Queue Threshold Map*

DSCP Value	Queue ID–Threshold ID
0–15	2–1
16–31	3–1
32–39	4–1
40–47	1–1
48–63	4–1

Default Mapping Table Configuration

The default CoS-to-DSCP map is shown in [Table 28-12 on page 28-52](#).

The default IP-precedence-to-DSCP map is shown in [Table 28-13 on page 28-53](#).

The default DSCP-to-CoS map is shown in [Table 28-14 on page 28-55](#).

The default DSCP-to-DSCP-mutation map is a null map, which maps an incoming DSCP value to the same DSCP value.

The default policed-DSCP map is a null map, which maps an incoming DSCP value to the same DSCP value (no markdown).

Standard QoS Configuration Guidelines

Before beginning the QoS configuration, you should be aware of this information in these sections:

- “[QoS ACL Guidelines](#)” section on page 28-32
- “[Policing Guidelines](#)” section on page 28-32
- “[General QoS Guidelines](#)” section on page 28-33

QoS ACL Guidelines

These are the guidelines with for configuring QoS with access control lists (ACLs):

- If you use QoS ACLs for classification, you can use the **sdm prefer qos** global configuration command to set the Switch Database Management (SDM) feature to the QoS template. SDM configures system resources to support the maximum number of access control entries (ACEs). For more information on the SDM templates, see [Chapter 7, “Configuring SDM Templates.”](#)
- It is not possible to match IP fragments against configured IP extended ACLs to enforce QoS. IP fragments are sent as best-effort. IP fragments are denoted by fields in the IP header.
- Only one ACL per class map and only one **match** class-map configuration command per class map are supported. The ACL can have multiple ACEs, which match fields against the contents of the packet.
- A trust statement in a policy map requires multiple TCAM entries per ACL line. If an input service policy map contains a trust statement in an ACL, the access-list might be too large to fit into the available QoS TCAM and an error can occur when you apply the policy map to a port. Whenever possible, you should minimize the number of lines in a QoS ACL.

Policing Guidelines

These are the policing guidelines:

- The port ASIC device, which controls more than one physical port, supports 256 policers (255 user-configurable policers plus 1 policer reserved for system internal use). The maximum number of user-configurable policers supported per port is 63. Policers are allocated on demand by the software and are constrained by the hardware and ASIC boundaries. You cannot reserve policers per port; there is no guarantee that a port will be assigned to any policer.
- Only one policer is applied to a packet on an ingress port. Only the average rate and committed burst parameters are configurable.

- You can set the policing rate only in 1-Mb/s increments. If you try to set a policing rate at less than 1 Mb/s, the switch prompts you for a correct value.
- On a port configured for QoS, all traffic received through the port is classified, policed, and marked according to the policy map attached to the port. On a trunk port configured for QoS, traffic in *all* VLANs received through the port is classified, policed, and marked according to the policy map attached to the port.
- If you have EtherChannel ports configured on your switch, you must configure QoS classification, policing, mapping, and queueing on the individual physical ports that comprise the EtherChannel. You must decide whether the QoS configuration should match on all ports in the EtherChannel.

General QoS Guidelines

These are general QoS guidelines:

- You configure QoS only on physical ports; there is no support for it at the VLAN or switch virtual interface level.
- Control traffic (such as spanning-tree bridge protocol data units [BPDUs] and routing update packets) received by the switch are subject to all ingress QoS processing.
- You are likely to lose data when you change queue settings; therefore, try to make changes when traffic is at a minimum.

Enabling QoS Globally

By default, QoS is disabled on the switch.

Beginning in privileged EXEC mode, follow these steps to enable QoS. This procedure is required.

	Command	Purpose
Step 1	configure terminal	Enter global configuration mode.
Step 2	mls qos	Enable QoS globally. QoS runs with the default settings described in the “Default Standard QoS Configuration” section on page 28-30, the “Queueing and Scheduling on Ingress Queues” section on page 28-14, and the “Queueing and Scheduling on Egress Queues” section on page 28-16.
Step 3	end	Return to privileged EXEC mode.
Step 4	show mls qos	Verify your entries.
Step 5	copy running-config startup-config	(Optional) Save your entries in the configuration file.

To disable QoS, use the **no mls qos** global configuration command.

Configuring Classification Using Port Trust States

These sections describe how to classify incoming traffic by using port trust states. Depending on your network configuration, you must perform one or more of these tasks or one or more of the tasks in the “Configuring a QoS Policy” section on page 28-40:

- [Configuring the Trust State on Ports within the QoS Domain, page 28-34](#)
- [Configuring the CoS Value for an Interface, page 28-36](#)
- [Configuring a Trusted Boundary to Ensure Port Security, page 28-36](#)
- [Enabling DSCP Transparency Mode, page 28-38](#)
- [Configuring the DSCP Trust State on a Port Bordering Another QoS Domain, page 28-38](#)

Configuring the Trust State on Ports within the QoS Domain

Packets entering a QoS domain are classified at the edge of the QoS domain. When the packets are classified at the edge, the switch port within the QoS domain can be configured to one of the trusted states because there is no need to classify the packets at every switch within the QoS domain.

[Figure 28-11](#) shows a sample network topology.

Figure 28-11 Port Trusted States within the QoS Domain

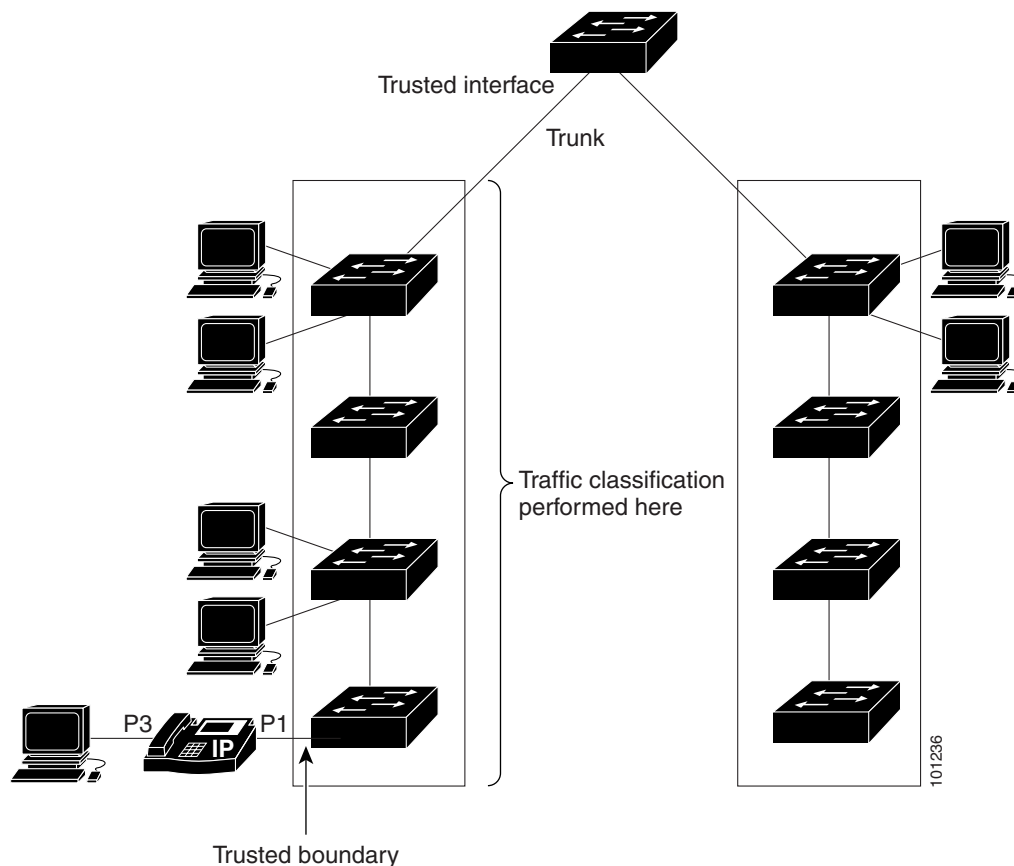

Beginning in privileged EXEC mode, follow these steps to configure the port to trust the classification of the traffic that it receives:

	Command	Purpose
Step 1	configure terminal	Enter global configuration mode.
Step 2	interface <i>interface-id</i>	Specify the port to be trusted, and enter interface configuration mode. Valid interfaces include physical ports.
Step 3	mls qos trust [cos dscp ip-precedence]	Configure the port trust state. By default, the port is not trusted. If no keyword is specified, the default is dscp . The keywords have these meanings: <ul style="list-style-type: none"> • cos—Classifies an ingress packet by using the packet CoS value. For an untagged packet, the port default CoS value is used. The default port CoS value is 0. • dscp—Classifies an ingress packet by using the packet DSCP value. For a non-IP packet, the packet CoS value is used if the packet is tagged; for an untagged packet, the default port CoS is used. Internally, the switch maps the CoS value to a DSCP value by using the CoS-to-DSCP map. • ip-precedence—Classifies an ingress packet by using the packet IP-precedence value. For a non-IP packet, the packet CoS value is used if the packet is tagged; for an untagged packet, the default port CoS is used. Internally, the switch maps the CoS value to a DSCP value by using the CoS-to-DSCP map.
Step 4	end	Return to privileged EXEC mode.
Step 5	show mls qos interface	Verify your entries.
Step 6	copy running-config startup-config	(Optional) Save your entries in the configuration file.

To return a port to its untrusted state, use the **no mls qos trust** interface configuration command.

For information on how to change the default CoS value, see the [“Configuring the CoS Value for an Interface”](#) section on page 28-36. For information on how to configure the CoS-to-DSCP map, see the [“Configuring the CoS-to-DSCP Map”](#) section on page 28-52.

Configuring the CoS Value for an Interface

QoS assigns the CoS value specified with the **mls qos cos** interface configuration command to untagged frames received on trusted and untrusted ports.

Beginning in privileged EXEC mode, follow these steps to define the default CoS value of a port or to assign the default CoS to all incoming packets on the port:

	Command	Purpose
Step 1	configure terminal	Enter global configuration mode.
Step 2	interface <i>interface-id</i>	Specify the port to be configured, and enter interface configuration mode. Valid interfaces include physical ports.
Step 3	mls qos cos { <i>default-cos</i> override }	Configure the default CoS value for the port. <ul style="list-style-type: none"> For <i>default-cos</i>, specify a default CoS value to be assigned to a port. If the packet is untagged, the default CoS value becomes the packet CoS value. The CoS range is 0 to 7. The default is 0. Use the override keyword to override the previously configured trust state of the incoming packet and to apply the default port CoS value to the port on all incoming packets. By default, CoS override is disabled. Use the override keyword when all incoming packets on specified ports deserve higher or lower priority than packets entering from other ports. Even if a port was previously set to trust DSCP, CoS, or IP precedence, this command overrides the previously configured trust state, and all the incoming CoS values are assigned the default CoS value configured with this command. If an incoming packet is tagged, the CoS value of the packet is modified with the default CoS of the port at the ingress port.
Step 4	end	Return to privileged EXEC mode.
Step 5	show mls qos interface	Verify your entries.
Step 6	copy running-config startup-config	(Optional) Save your entries in the configuration file.

To return to the default setting, use the **no mls qos cos** {*default-cos* | **override**} interface configuration command.

Configuring a Trusted Boundary to Ensure Port Security

In a typical network, you connect a Cisco IP Phone to a switch port, as shown in [Figure 28-11 on page 28-34](#), and cascade devices that generate data packets from the back of the telephone. The Cisco IP Phone guarantees the voice quality through a shared data link by marking the CoS level of the voice packets as high priority (CoS = 5) and by marking the data packets as low priority (CoS = 0). Traffic sent from the telephone to the switch is typically marked with a tag that uses the IEEE 802.1Q header. The header contains the VLAN information and the class of service (CoS) 3-bit field, which is the priority of the packet.

For most Cisco IP Phone configurations, the traffic sent from the telephone to the switch should be trusted to ensure that voice traffic is properly prioritized over other types of traffic in the network. By using the **mls qos trust cos** interface configuration command, you configure the switch port to which

the telephone is connected to trust the CoS labels of all traffic received on that port. Use the **mls qos trust dscp** interface configuration command to configure a routed port to which the telephone is connected to trust the DSCP labels of all traffic received on that port.

With the trusted setting, you also can use the trusted boundary feature to prevent misuse of a high-priority queue if a user bypasses the telephone and connects the PC directly to the switch. Without trusted boundary, the CoS labels generated by the PC are trusted by the switch (because of the trusted CoS setting). By contrast, trusted boundary uses CDP to detect the presence of a Cisco IP Phone (such as the Cisco IP Phone 7910, 7935, 7940, and 7960) on a switch port. If the telephone is not detected, the trusted boundary feature disables the trusted setting on the switch port and prevents misuse of a high-priority queue. Note that the trusted boundary feature is not effective if the PC and Cisco IP Phone are connected to a hub that is connected to the switch.

In some situations, you can prevent a PC connected to the Cisco IP Phone from taking advantage of a high-priority data queue. You can use the **switchport priority extend cos** interface configuration command to configure the telephone through the switch CLI to override the priority of the traffic received from the PC.

Beginning in privileged EXEC mode, follow these steps to enable trusted boundary on a port:

	Command	Purpose
Step 1	configure terminal	Enter global configuration mode.
Step 2	cdp run	Enable CDP globally. By default, CDP is enabled.
Step 3	interface <i>interface-id</i>	Specify the port connected to the Cisco IP Phone, and enter interface configuration mode. Valid interfaces include physical ports.
Step 4	cdp enable	Enable CDP on the port. By default, CDP is enabled.
Step 5	mls qos trust cos mls qos trust dscp	Configure the switch port to trust the CoS value in traffic received from the Cisco IP Phone. or Configure the routed port to trust the DSCP value in traffic received from the Cisco IP Phone. By default, the port is not
Step 6	mls qos trust device cisco-phone	Specify that the Cisco IP Phone is a trusted device. You cannot enable both trusted boundary and auto-QoS (auto qos voip interface configuration command) at the same time; they are mutually exclusive.
Step 7	end	Return to privileged EXEC mode.
Step 8	show mls qos interface	Verify your entries.
Step 9	copy running-config startup-config	(Optional) Save your entries in the configuration file.

To disable the trusted boundary feature, use the **no mls qos trust device** interface configuration command.

Enabling DSCP Transparency Mode

The switch supports the DSCP transparency feature. It affects only the DSCP field of a packet at egress. By default, DSCP transparency is disabled. The switch modifies the DSCP field in an incoming packet, and the DSCP field in the outgoing packet is based on the quality of service (QoS) configuration, including the port trust setting, policing and marking, and the DSCP-to-DSCP mutation map.

If DSCP transparency is enabled by using the **no mls qos rewrite ip dscp** command, the switch does not modify the DSCP field in the incoming packet, and the DSCP field in the outgoing packet is the same as that in the incoming packet.

Regardless of the DSCP transparency configuration, the switch modifies the internal DSCP value of the packet, which the switch uses to generate a class of service (CoS) value that represents the priority of the traffic. The switch also uses the internal DSCP value to select an egress queue and threshold.

Beginning in privileged EXEC mode, follow these steps to enable DSCP transparency on a switch:

	Command	Purpose
Step 1	configure terminal	Enter global configuration mode.
Step 2	mls qos	Enable QoS globally.
Step 3	no mls qos rewrite ip dscp	Enable DSCP transparency. The switch is configured to not modify the DSCP field of the IP packet.
Step 4	end	Return to privileged EXEC mode.
Step 5	show mls qos interface <i>[interface-id]</i>	Verify your entries.
Step 6	copy running-config startup-config	(Optional) Save your entries in the configuration file.

To configure the switch to modify the DSCP value based on the trust setting or on an ACL by disabling DSCP transparency, use the **mls qos rewrite ip dscp** global configuration command.

If you disable QoS by using the **no mls qos** global configuration command, the CoS and DSCP values are not changed (the default QoS setting).

If you enter the **no mls qos rewrite ip dscp** global configuration command to enable DSCP transparency and then enter the **mls qos trust [cos | dscp]** interface configuration command, DSCP transparency is still enabled.

Configuring the DSCP Trust State on a Port Bordering Another QoS Domain

If you are administering two separate QoS domains between which you want to implement QoS features for IP traffic, you can configure the switch ports bordering the domains to a DSCP-trusted state as shown in [Figure 28-12](#). Then the receiving port accepts the DSCP-trusted value and avoids the classification stage of QoS. If the two domains use different DSCP values, you can configure the DSCP-to-DSCP-mutation map to translate a set of DSCP values to match the definition in the other domain.

Figure 28-12 DSCP-Trusted State on a Port Bordering Another QoS Domain

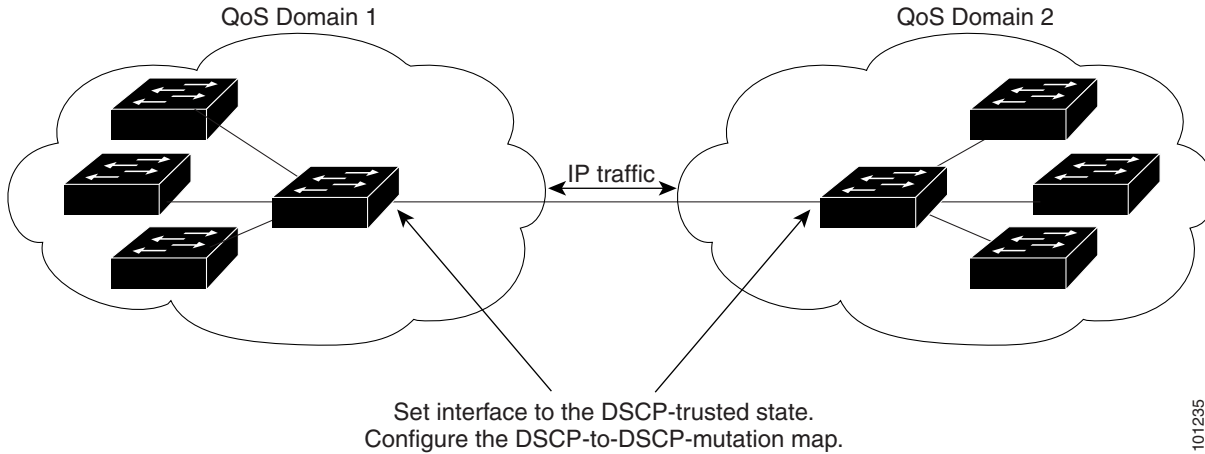

Beginning in privileged EXEC mode, follow these steps to configure the DSCP-trusted state on a port and modify the DSCP-to-DSCP-mutation map. To ensure a consistent mapping strategy across both QoS domains, you must perform this procedure on the ports in both domains:

	Command	Purpose
Step 1	configure terminal	Enter global configuration mode.
Step 2	mls qos map dscp-mutation <i>dscp-mutation-name in-dscp to out-dscp</i>	Modify the DSCP-to-DSCP-mutation map. The default DSCP-to-DSCP-mutation map is a null map, which maps an incoming DSCP value to the same DSCP value. <ul style="list-style-type: none"> For <i>dscp-mutation-name</i>, enter the mutation map name. You can create more than one map by specifying a new name. For <i>in-dscp</i>, enter up to eight DSCP values separated by spaces. Then enter the to keyword. For <i>out-dscp</i>, enter a single DSCP value. The DSCP range is 0 to 63.
Step 3	interface <i>interface-id</i>	Specify the port to be trusted, and enter interface configuration mode. Valid interfaces include physical ports.
Step 4	mls qos trust dscp	Configure the ingress port as a DSCP-trusted port. By default, the port is not trusted.
Step 5	mls qos dscp-mutation <i>dscp-mutation-name</i>	Apply the map to the specified ingress DSCP-trusted port. For <i>dscp-mutation-name</i> , specify the mutation map name created in Step 2. You can configure multiple DSCP-to-DSCP-mutation maps on an ingress port.
Step 6	end	Return to privileged EXEC mode.
Step 7	show mls qos maps dscp-mutation	Verify your entries.
Step 8	copy running-config startup-config	(Optional) Save your entries in the configuration file.

To return a port to its non-trusted state, use the **no mls qos trust** interface configuration command. To return to the default DSCP-to-DSCP-mutation map values, use the **no mls qos map dscp-mutation dscp-mutation-name** global configuration command.

This example shows how to configure a port to the DSCP-trusted state and to modify the DSCP-to-DSCP-mutation map (named *gi0/2-mutation*) so that incoming DSCP values 10 to 13 are mapped to DSCP 30:

```
Switch(config)# mls qos map dscp-mutation gi0/2-mutation 10 11 12 13 to 30
Switch(config)# interface gigabitethernet0/2
Switch(config-if)# mls qos trust dscp
Switch(config-if)# mls qos dscp-mutation gi0/2-mutation
Switch(config-if)# end
```

Configuring a QoS Policy

Configuring a QoS policy typically requires classifying traffic into classes, configuring policies applied to those traffic classes, and attaching policies to ports.

For background information, see the [“Classification” section on page 28-5](#) and the [“Policing and Marking” section on page 28-8](#). For configuration guidelines, see the [“Standard QoS Configuration Guidelines” section on page 28-32](#).

These sections describe how to classify, police, and mark traffic. Depending on your network configuration, you must perform one or more of these tasks:

- [Classifying Traffic by Using ACLs, page 28-41](#)
- [Classifying Traffic by Using Class Maps, page 28-44](#)
- [Classifying, Policing, and Marking Traffic on Physical Ports by Using Policy Maps, page 28-46](#)
- [Classifying, Policing, and Marking Traffic by Using Aggregate Policers, page 28-49](#)

Classifying Traffic by Using ACLs

You can classify IP traffic by using IP standard or IP extended ACLs; you can classify non-IP traffic by using Layer 2 MAC ACLs.

Beginning in privileged EXEC mode, follow these steps to create an IP standard ACL for IP traffic:

	Command	Purpose
Step 1	<code>configure terminal</code>	Enter global configuration mode.
Step 2	<code>access-list access-list-number {deny permit} source [source-wildcard]</code>	<p>Create an IP standard ACL, repeating the command as many times as necessary.</p> <ul style="list-style-type: none"> For <i>access-list-number</i>, enter the access list number. The range is 1 to 99 and 1300 to 1999. Use the permit keyword to permit a certain type of traffic if the conditions are matched. Use the deny keyword to deny a certain type of traffic if conditions are matched. For <i>source</i>, enter the network or host from which the packet is being sent. You can use the any keyword as an abbreviation for 0.0.0.0 255.255.255.255. (Optional) For <i>source-wildcard</i>, enter the wildcard bits in dotted decimal notation to be applied to the source. Place ones in the bit positions that you want to ignore. <p>Note When creating an access list, remember that, by default, the end of the access list contains an implicit deny statement for everything if it did not find a match before reaching the end.</p>
Step 3	<code>end</code>	Return to privileged EXEC mode.
Step 4	<code>show access-lists</code>	Verify your entries.
Step 5	<code>copy running-config startup-config</code>	(Optional) Save your entries in the configuration file.

To delete an access list, use the **no access-list** *access-list-number* global configuration command.

This example shows how to allow access for only those hosts on the three specified networks. The wildcard bits apply to the host portions of the network addresses. Any host with a source address that does not match the access list statements is rejected.

```
Switch(config)# access-list 1 permit 192.5.255.0 0.0.0.255
Switch(config)# access-list 1 permit 128.88.0.0 0.0.255.255
Switch(config)# access-list 1 permit 36.0.0.0 0.0.0.255
! (Note: all other access implicitly denied)
```

Beginning in privileged EXEC mode, follow these steps to create an IP extended ACL for IP traffic:

	Command	Purpose
Step 1	configure terminal	Enter global configuration mode.
Step 2	access-list <i>access-list-number</i> { deny permit } <i>protocol source source-wildcard destination destination-wildcard</i>	<p>Create an IP extended ACL, repeating the command as many times as necessary.</p> <ul style="list-style-type: none"> For <i>access-list-number</i>, enter the access list number. The range is 100 to 199 and 2000 to 2699. Use the permit keyword to permit a certain type of traffic if the conditions are matched. Use the deny keyword to deny a certain type of traffic if conditions are matched. For <i>protocol</i>, enter the name or number of an IP protocol. Use the question mark (?) to see a list of available protocol keywords. For <i>source</i>, enter the network or host from which the packet is being sent. You specify this by using dotted decimal notation, by using the any keyword as an abbreviation for <i>source</i> 0.0.0.0 <i>source-wildcard</i> 255.255.255.255, or by using the host keyword for <i>source</i> 0.0.0.0. For <i>source-wildcard</i>, enter the wildcard bits by placing ones in the bit positions that you want to ignore. You specify the wildcard by using dotted decimal notation, by using the any keyword as an abbreviation for <i>source</i> 0.0.0.0 <i>source-wildcard</i> 255.255.255.255, or by using the host keyword for <i>source</i> 0.0.0.0. For <i>destination</i>, enter the network or host to which the packet is being sent. You have the same options for specifying the <i>destination</i> and <i>destination-wildcard</i> as those described by <i>source</i> and <i>source-wildcard</i>. <p>Note When creating an access list, remember that, by default, the end of the access list contains an implicit deny statement for everything if it did not find a match before reaching the end.</p>
Step 3	end	Return to privileged EXEC mode.
Step 4	show access-lists	Verify your entries.
Step 5	copy running-config startup-config	(Optional) Save your entries in the configuration file.

To delete an access list, use the **no access-list** *access-list-number* global configuration command.

This example shows how to create an ACL that permits IP traffic from any source to any destination that has the DSCP value set to 32:

```
Switch(config)# access-list 100 permit ip any any dscp 32
```

This example shows how to create an ACL that permits IP traffic from a source host at 10.1.1.1 to a destination host at 10.1.1.2 with a precedence value of 5:

```
Switch(config)# access-list 100 permit ip host 10.1.1.1 host 10.1.1.2 precedence 5
```

This example shows how to create an ACL that permits PIM traffic from any source to a destination group address of 224.0.0.2 with a DSCP set to 32:

```
Switch(config)# access-list 102 permit pim any 224.0.0.2 dscp 32
```

Beginning in privileged EXEC mode, follow these steps to create a Layer 2 MAC ACL for non-IP traffic:

	Command	Purpose
Step 1	configure terminal	Enter global configuration mode.
Step 2	mac access-list extended <i>name</i>	Create a Layer 2 MAC ACL by specifying the name of the list. After entering this command, the mode changes to extended MAC ACL configuration.
Step 3	{ permit deny } { host <i>src-MAC-addr mask</i> any host <i>dst-MAC-addr</i> <i>dst-MAC-addr mask</i> } [<i>type mask</i>]	Specify the type of traffic to permit or deny if the conditions are matched, entering the command as many times as necessary. <ul style="list-style-type: none"> For <i>src-MAC-addr</i>, enter the MAC address of the host from which the packet is being sent. You specify this by using the hexadecimal format (H.H.H), by using the any keyword as an abbreviation for <i>source</i> 0.0.0, <i>source-wildcard</i> ffff.ffff.ffff, or by using the host keyword for <i>source</i> 0.0.0. For <i>mask</i>, enter the wildcard bits by placing ones in the bit positions that you want to ignore. For <i>dst-MAC-addr</i>, enter the MAC address of the host to which the packet is being sent. You specify this by using the hexadecimal format (H.H.H), by using the any keyword as an abbreviation for <i>source</i> 0.0.0, <i>source-wildcard</i> ffff.ffff.ffff, or by using the host keyword for <i>source</i> 0.0.0. (Optional) For <i>type mask</i>, specify the Ethertype number of a packet with Ethernet II or SNAP encapsulation to identify the protocol of the packet. For <i>type</i>, the range is from 0 to 65535, typically specified in hexadecimal. For <i>mask</i>, enter the <i>don't care</i> bits applied to the Ethertype before testing for a match. <p>Note When creating an access list, remember that, by default, the end of the access list contains an implicit deny statement for everything if it did not find a match before reaching the end.</p>
Step 4	end	Return to privileged EXEC mode.
Step 5	show access-lists [<i>access-list-number</i> <i>access-list-name</i>]	Verify your entries.
Step 6	copy running-config startup-config	(Optional) Save your entries in the configuration file.

To delete an access list, use the **no mac access-list extended** *access-list-name* global configuration command.

This example shows how to create a Layer 2 MAC ACL with two permit statements. The first statement allows traffic from the host with MAC address 0001.0000.0001 to the host with MAC address 0002.0000.0001. The second statement allows only Ethertype XNS-IDP traffic from the host with MAC address 0001.0000.0002 to the host with MAC address 0002.0000.0002.

```
Switch(config)# mac access-list extended maclist1
Switch(config-ext-macl)# permit 0001.0000.0001 0.0.0 0002.0000.0001 0.0.0
Switch(config-ext-macl)# permit 0001.0000.0002 0.0.0 0002.0000.0002 0.0.0 xns-idp
! (Note: all other access implicitly denied)
```

Classifying Traffic by Using Class Maps

You use the **class-map** global configuration command to name and to isolate a specific traffic flow (or class) from all other traffic. The class map defines the criteria to use to match against a specific traffic flow to further classify it. Match statements can include criteria such as an ACL, IP precedence values, or DSCP values. The match criterion is defined with one match statement entered within the class-map configuration mode.



Note

You can also create class-maps during policy map creation by using the **class** policy-map configuration command. For more information, see the [“Classifying, Policing, and Marking Traffic on Physical Ports by Using Policy Maps”](#) section on page 28-46.

Beginning in privileged EXEC mode, follow these steps to create a class map and to define the match criterion to classify traffic:

	Command	Purpose
Step 1	configure terminal	Enter global configuration mode.
Step 2	access-list <i>access-list-number</i> {deny permit} <i>source</i> [<i>source-wildcard</i>] or access-list <i>access-list-number</i> {deny permit} <i>protocol source</i> [<i>source-wildcard</i>] <i>destination</i> [<i>destination-wildcard</i>] or mac access-list extended <i>name</i> {permit deny} {host <i>src-MAC-addr mask</i> any host <i>dst-MAC-addr</i> <i>dst-MAC-addr mask</i> } [<i>type mask</i>]	Create an IP standard or extended ACL for IP traffic or a Layer 2 MAC ACL for non-IP traffic, repeating the command as many times as necessary. For more information, see the “Classifying Traffic by Using ACLs” section on page 28-41. Note When creating an access list, remember that, by default, the end of the access list contains an implicit deny statement for everything if it did not find a match before reaching the end.
Step 3	class-map [match-all match-any] <i>class-map-name</i>	Create a class map, and enter class-map configuration mode. By default, no class maps are defined. <ul style="list-style-type: none"> • (Optional) Use the match-all keyword to perform a logical-AND of all matching statements under this class map. All match criteria in the class map must be matched. • (Optional) Use the match-any keyword to perform a logical-OR of all matching statements under this class map. One or more match criteria must be matched. • For <i>class-map-name</i>, specify the name of the class map. If neither the match-all or match-any keyword is specified, the default is match-all . Note Because only one match command per class map is supported, the match-all and match-any keywords function the same.

	Command	Purpose
Step 4	match { access-group <i>acl-index-or-name</i> ip dscp <i>dscp-list</i> ip precedence <i>ip-precedence-list</i> }	<p>Define the match criterion to classify traffic.</p> <p>By default, no match criterion is defined.</p> <p>Only one match criterion per class map is supported, and only one ACL per class map is supported.</p> <ul style="list-style-type: none"> For access-group <i>acl-index-or-name</i>, specify the number or name of the ACL created in Step 2. For ip dscp <i>dscp-list</i>, enter a list of up to eight IP DSCP values to match against incoming packets. Separate each value with a space. The range is 0 to 63. For ip precedence <i>ip-precedence-list</i>, enter a list of up to eight IP-precedence values to match against incoming packets. Separate each value with a space. The range is 0 to 7.
Step 5	end	Return to privileged EXEC mode.
Step 6	show class-map	Verify your entries.
Step 7	copy running-config startup-config	(Optional) Save your entries in the configuration file.

To delete an existing policy map, use the **no policy-map** *policy-map-name* global configuration command. To delete an existing class map, use the **no class-map** [**match-all** | **match-any**] *class-map-name* global configuration command. To remove a match criterion, use the **no match** {**access-group** *acl-index-or-name* | **ip dscp** | **ip precedence**} class-map configuration command.

This example shows how to configure the class map called *class1*. The *class1* has one match criterion, which is access list 103. It permits traffic from any host to any destination that matches a DSCP value of 10.

```
Switch(config)# access-list 103 permit any any dscp 10
Switch(config)# class-map class1
Switch(config-cmap)# match access-group 103
Switch(config-cmap)# end
Switch#
```

This example shows how to create a class map called *class2*, which matches incoming traffic with DSCP values of 10, 11, and 12.

```
Switch(config)# class-map class2
Switch(config-cmap)# match ip dscp 10 11 12
Switch(config-cmap)# end
Switch#
```

This example shows how to create a class map called *class3*, which matches incoming traffic with IP-precedence values of 5, 6, and 7:

```
Switch(config)# class-map class3
Switch(config-cmap)# match ip precedence 5 6 7
Switch(config-cmap)# end
Switch#
```

Classifying, Policing, and Marking Traffic on Physical Ports by Using Policy Maps

You can configure a policy map on a physical port that specifies which traffic class to act on. Actions can include trusting the CoS, DSCP, or IP precedence values in the traffic class; setting a specific DSCP or IP precedence value in the traffic class; and specifying the traffic bandwidth limitations for each matched traffic class (policer) and the action to take when the traffic is out of profile (marking).

A policy map also has these characteristics:

- A policy map can contain multiple class statements, each with different match criteria and policers.
- A separate policy-map class can exist for each type of traffic received through a port.
- A policy-map trust state and a port trust state are mutually exclusive, and whichever is configured last takes affect.

Follow these guidelines when configuring policy maps on physical ports:

- You can attach only one policy map per ingress port.
- If you configure the IP-precedence-to-DSCP map by using the **mls qos map ip-prec-dscp dscp1...dscp8** global configuration command, the settings only affect packets on ingress interfaces that are configured to trust the IP precedence value. In a policy map, if you set the packet IP precedence value to a new value by using the **set ip precedence new-precedence** policy-map class configuration command, the egress DSCP value is not affected by the IP-precedence-to-DSCP map. If you want the egress DSCP value to be different than the ingress value, use the **set dscp new-dscp** policy-map class configuration command.
- If you enter or have used the **set ip dscp** command, the switch changes this command to **set dscp** in its configuration.
- In Cisco IOS Release 12.2(25)SED or later, you can use the **set ip precedence** or the **set precedence** policy-map class configuration command to change the packet IP precedence value. This setting appears as **set ip precedence** in the switch configuration.
- Beginning with Cisco IOS Release 12.2(40)SE, a policy-map and a port trust state can both run on a physical interface. The policy-map is applied before the port trust state.

Beginning in privileged EXEC mode, follow these steps to create a policy map:

	Command	Purpose
Step 1	configure terminal	Enter global configuration mode.
Step 2	class-map [match-all match-any] <i>class-map-name</i>	<p>Create a class map, and enter class-map configuration mode.</p> <p>By default, no class maps are defined.</p> <ul style="list-style-type: none"> • (Optional) Use the match-all keyword to perform a logical-AND of all matching statements under this class map. All match criteria in the class map must be matched. • (Optional) Use the match-any keyword to perform a logical-OR of all matching statements under this class map. One or more match criteria must be matched. • For <i>class-map-name</i>, specify the name of the class map. <p>If neither the match-all or match-any keyword is specified, the default is match-all.</p> <p>Note Because only one match command per class map is supported, the match-all and match-any keywords function the same.</p>

	Command	Purpose
Step 3	policy-map <i>policy-map-name</i>	<p>Create a policy map by entering the policy map name, and enter policy-map configuration mode.</p> <p>By default, no policy maps are defined.</p> <p>The default behavior of a policy map is to set the DSCP to 0 if the packet is an IP packet and to set the CoS to 0 if the packet is tagged. No policing is performed.</p>
Step 4	class <i>class-map-name</i>	<p>Define a traffic classification, and enter policy-map class configuration mode.</p> <p>By default, no policy map class-maps are defined.</p> <p>If a traffic class has already been defined by using the class-map global configuration command, specify its name for <i>class-map-name</i> in this command.</p>
Step 5	trust [cos dscp ip-precedence]	<p>Configure the trust state, which QoS uses to generate a CoS-based or DSCP-based QoS label.</p> <p>Note This command is mutually exclusive with the set command within the same policy map. If you enter the trust command, go to Step 6.</p> <p>By default, the port is not trusted. If no keyword is specified when the command is entered, the default is dscp.</p> <p>The keywords have these meanings:</p> <ul style="list-style-type: none"> • cos—QoS derives the DSCP value by using the received or default port CoS value and the CoS-to-DSCP map. • dscp—QoS derives the DSCP value by using the DSCP value from the ingress packet. For non-IP packets that are tagged, QoS derives the DSCP value by using the received CoS value; for non-IP packets that are untagged, QoS derives the DSCP value by using the default port CoS value. In either case, the DSCP value is derived from the CoS-to-DSCP map. • ip-precedence—QoS derives the DSCP value by using the IP precedence value from the ingress packet and the IP-precedence-to-DSCP map. For non-IP packets that are tagged, QoS derives the DSCP value by using the received CoS value; for non-IP packets that are untagged, QoS derives the DSCP value by using the default port CoS value. In either case, the DSCP value is derived from the CoS-to-DSCP map. <p>For more information, see the “Configuring the CoS-to-DSCP Map” section on page 28-52.</p>
Step 6	set { dscp <i>new-dscp</i> ip precedence <i>new-precedence</i> }	<p>Classify IP traffic by setting a new value in the packet.</p> <ul style="list-style-type: none"> • For dscp <i>new-dscp</i>, enter a new DSCP value to be assigned to the classified traffic. The range is 0 to 63. • For ip precedence <i>new-precedence</i>, enter a new IP-precedence value to be assigned to the classified traffic. The range is 0 to 7.

	Command	Purpose
Step 7	police <i>rate-bps burst-byte</i> [exceed-action { drop policed-dscp-transmit }]	<p>Define a policer for the classified traffic.</p> <p>By default, no policer is defined. For information on the number of policers supported, see the “Standard QoS Configuration Guidelines” section on page 28-32.</p> <ul style="list-style-type: none"> For <i>rate-bps</i>, specify average traffic rate in bits per second (b/s). The range is 1000000 to 1000000000. You can set the policing rate only in 1-Mb/s increments. If you try to set a policing rate at less than 1 Mb/s, the switch prompts you for a correct value. For <i>burst-byte</i>, specify the normal burst size in bytes. The range is 8000 to 1000000. (Optional) Specify the action to take when the rates are exceeded. Use the exceed-action drop keywords to drop the packet. Use the exceed-action policed-dscp-transmit keywords to mark down the DSCP value (by using the policed-DSCP map) and to send the packet. For more information, see the “Configuring the Policed-DSCP Map” section on page 28-54.
Step 8	exit	Return to policy map configuration mode.
Step 9	exit	Return to global configuration mode.
Step 10	interface <i>interface-id</i>	<p>Specify the port to attach to the policy map, and enter interface configuration mode.</p> <p>Valid interfaces include physical ports.</p>
Step 11	service-policy input <i>policy-map-name</i>	<p>Specify the policy-map name, and apply it to an ingress port.</p> <p>Only one policy map per ingress port is supported.</p>
Step 12	end	Return to privileged EXEC mode.
Step 13	show policy-map [<i>policy-map-name</i> [class <i>class-map-name</i>]]	Verify your entries.
Step 14	copy running-config startup-config	(Optional) Save your entries in the configuration file.

To delete an existing policy map, use the **no policy-map** *policy-map-name* global configuration command. To delete an existing class map, use the **no class** *class-map-name* policy-map configuration command. To return to the untrusted state, use the **no trust** policy-map configuration command. To remove an assigned DSCP or IP precedence value, use the **no set** {**dscp** *new-dscp* | **ip precedence** *new-precedence*} policy-map configuration command. To remove an existing policer, use the **no police** *rate-bps burst-byte* [**exceed-action** {**drop** | **policed-dscp-transmit**}] policy-map configuration command. To remove the policy map and port association, use the **no service-policy input** *policy-map-name* interface configuration command.

This example shows how to create a policy map and attach it to an ingress port. In the configuration, the IP standard ACL permits traffic from network 10.1.0.0. For traffic matching this classification, the DSCP value in the incoming packet is trusted. If the matched traffic exceeds an average traffic rate of 48000 b/s and a normal burst size of 8000 bytes, its DSCP is marked down (based on the policed-DSCP map) and sent:

```
Switch(config)# access-list 1 permit 10.1.0.0 0.0.255.255
Switch(config)# class-map ipclass1
Switch(config-cmap)# match access-group 1
Switch(config-cmap)# exit
Switch(config)# policy-map flow1t
```

```
Switch(config-pmap)# class ipclass1
Switch(config-pmap-c)# trust dscp
Switch(config-pmap-c)# police 1000000 8000 exceed-action policed-dscp-transmit
Switch(config-pmap-c)# exit
Switch(config-pmap)# exit
Switch(config)# interface gigabitethernet0/1
Switch(config-if)# service-policy input flow1t
```

This example shows how to create a Layer 2 MAC ACL with two permit statements and attach it to an ingress port. The first permit statement allows traffic from the host with MAC address 0001.0000.0001 destined for the host with MAC address 0002.0000.0001. The second permit statement allows only Ethertype XNS-IDP traffic from the host with MAC address 0001.0000.0002 destined for the host with MAC address 0002.0000.0002.

```
Switch(config)# mac access-list extended maclist1
Switch(config-ext-mac)# permit 0001.0000.0001 0.0.0 0002.0000.0001 0.0.0
Switch(config-ext-mac)# permit 0001.0000.0002 0.0.0 0002.0000.0002 0.0.0 xns-idp
Switch(config-ext-mac)# exit
Switch(config)# mac access-list extended maclist2
Switch(config-ext-mac)# permit 0001.0000.0003 0.0.0 0002.0000.0003 0.0.0
Switch(config-ext-mac)# permit 0001.0000.0004 0.0.0 0002.0000.0004 0.0.0 aarp
Switch(config-ext-mac)# exit
Switch(config)# class-map macclass1
Switch(config-cmap)# match access-group maclist1
Switch(config-cmap)# exit
Switch(config)# policy-map macpolicy1
Switch(config-pmap)# class macclass1
Switch(config-pmap-c)# set dscp 63
Switch(config-pmap-c)# exit
Switch(config-pmap)# class macclass2 maclist2
Switch(config-pmap-c)# set dscp 45
Switch(config-pmap-c)# exit
Switch(config-pmap)# exit
Switch(config)# interface gigabitethernet0/1
Switch(config-if)# mls qos trust cos
Switch(config-if)# service-policy input macpolicy1
```

- Beginning with Cisco IOS Release 12.2(40)SE, a policy-map and a port trust state can both run on a physical interface. The policy-map is applied before the port trust state.

Classifying, Policing, and Marking Traffic by Using Aggregate Policers

By using an aggregate policer, you can create a policer that is shared by multiple traffic classes within the same policy map. However, you cannot use the aggregate policer across different policy maps or ports.

Beginning in privileged EXEC mode, follow these steps to create an aggregate policer:

	Command	Purpose
Step 1	configure terminal	Enter global configuration mode.
Step 2	mls qos aggregate-policer <i>aggregate-policer-name rate-bps burst-byte</i> exceed-action {drop policed-dscp-transmit}	<p>Define the policer parameters that can be applied to multiple traffic classes within the same policy map.</p> <p>By default, no aggregate policer is defined. For information on the number of policers supported, see the “Standard QoS Configuration Guidelines” section on page 28-32.</p> <ul style="list-style-type: none"> For <i>aggregate-policer-name</i>, specify the name of the aggregate policer. For <i>rate-bps</i>, specify average traffic rate in bits per second (b/s). The range is 1000000 to 1000000000. You can set the policing rate only in 1-Mb/s increments. If you try to set a policing rate at less than 1 Mb/s, the switch prompts you for a correct value. For <i>burst-byte</i>, specify the normal burst size in bytes. The range is 8000 to 1000000. Specify the action to take when the rates are exceeded. Use the exceed-action drop keywords to drop the packet. Use the exceed-action policed-dscp-transmit keywords to mark down the DSCP value (by using the policed-DSCP map) and to send the packet. For more information, see the “Configuring the Policed-DSCP Map” section on page 28-54.
Step 3	class-map [match-all match-any] <i>class-map-name</i>	Create a class map to classify traffic as necessary. For more information, see the “Classifying Traffic by Using Class Maps” section on page 28-44.
Step 4	policy-map <i>policy-map-name</i>	<p>Create a policy map by entering the policy map name, and enter policy-map configuration mode.</p> <p>For more information, see the “Classifying, Policing, and Marking Traffic on Physical Ports by Using Policy Maps” section on page 28-46.</p>
Step 5	class <i>class-map-name</i>	<p>Define a traffic classification, and enter policy-map class configuration mode.</p> <p>For more information, see the “Classifying, Policing, and Marking Traffic on Physical Ports by Using Policy Maps” section on page 28-46.</p>
Step 6	police aggregate <i>aggregate-policer-name</i>	<p>Apply an aggregate policer to multiple classes in the same policy map.</p> <p>For <i>aggregate-policer-name</i>, enter the name specified in Step 2.</p>
Step 7	exit	Return to global configuration mode.
Step 8	interface <i>interface-id</i>	<p>Specify the port to attach to the policy map, and enter interface configuration mode.</p> <p>Valid interfaces include physical ports.</p>

	Command	Purpose
Step 9	service-policy input <i>policy-map-name</i>	Specify the policy-map name, and apply it to an ingress port. Only one policy map per ingress port is supported.
Step 10	end	Return to privileged EXEC mode.
Step 11	show mls qos aggregate-policer [<i>aggregate-policer-name</i>]	Verify your entries.
Step 12	copy running-config startup-config	(Optional) Save your entries in the configuration file.

To remove the specified aggregate policer from a policy map, use the **no police aggregate** *aggregate-policer-name* policy map configuration mode. To delete an aggregate policer and its parameters, use the **no mls qos aggregate-policer** *aggregate-policer-name* global configuration command.

This example shows how to create an aggregate policer and attach it to multiple classes within a policy map. In the configuration, the IP ACLs permit traffic from network 10.1.0.0 and from host 11.3.1.1. For traffic coming from network 10.1.0.0, the DSCP in the incoming packets is trusted. For traffic coming from host 11.3.1.1, the DSCP in the packet is changed to 56. The traffic rate from the 10.1.0.0 network and from host 11.3.1.1 is policed. If the traffic exceeds an average rate of 48000 b/s and a normal burst size of 8000 bytes, its DSCP is marked down (based on the policed-DSCP map) and sent. The policy map is attached to an ingress port.

```
Switch(config)# access-list 1 permit 10.1.0.0 0.0.255.255
Switch(config)# access-list 2 permit 11.3.1.1
Switch(config)# mls qos aggregate-police transmit1 48000 8000 exceed-action
policed-dscp-transmit
Switch(config)# class-map ipclass1
Switch(config-cmap)# match access-group 1
Switch(config-cmap)# exit
Switch(config)# class-map ipclass2
Switch(config-cmap)# match access-group 2
Switch(config-cmap)# exit
Switch(config)# policy-map aggflow1
Switch(config-pmap)# class ipclass1
Switch(config-pmap-c)# trust dscp
Switch(config-pmap-c)# police aggregate transmit1
Switch(config-pmap-c)# exit
Switch(config-pmap)# class ipclass2
Switch(config-pmap-c)# set dscp 56
Switch(config-pmap-c)# police aggregate transmit1
Switch(config-pmap-c)# exit
Switch(config-pmap)# exit
Switch(config)# interface gigabitethernet0/1
Switch(config-if)# service-policy input aggflow1
Switch(config-if)# exit
```

Configuring DSCP Maps

These sections contain this configuration information:

- [Configuring the CoS-to-DSCP Map, page 28-52](#) (optional)
- [Configuring the IP-Precedence-to-DSCP Map, page 28-53](#) (optional)
- [Configuring the Policed-DSCP Map, page 28-54](#) (optional, unless the null settings in the map are not appropriate)

- [Configuring the DSCP-to-CoS Map, page 28-55](#) (optional)
- [Configuring the DSCP-to-DSCP-Mutation Map, page 28-56](#) (optional, unless the null settings in the map are not appropriate)

All the maps, except the DSCP-to-DSCP-mutation map, are globally defined and are applied to all ports.

Configuring the CoS-to-DSCP Map

You use the CoS-to-DSCP map to map CoS values in incoming packets to a DSCP value that QoS uses internally to represent the priority of the traffic.

[Table 28-12](#) shows the default CoS-to-DSCP map.

Table 28-12 Default CoS-to-DSCP Map

CoS Value	DSCP Value
0	0
1	8
2	16
3	24
4	32
5	40
6	48
7	56

If these values are not appropriate for your network, you need to modify them.

Beginning in privileged EXEC mode, follow these steps to modify the CoS-to-DSCP map. This procedure is optional.

	Command	Purpose
Step 1	<code>configure terminal</code>	Enter global configuration mode.
Step 2	<code>mls qos map cos-dscp <i>dscp1...dscp8</i></code>	Modify the CoS-to-DSCP map. For <i>dscp1...dscp8</i> , enter eight DSCP values that correspond to CoS values 0 to 7. Separate each DSCP value with a space. The DSCP range is 0 to 63.
Step 3	<code>end</code>	Return to privileged EXEC mode.
Step 4	<code>show mls qos maps cos-dscp</code>	Verify your entries.
Step 5	<code>copy running-config startup-config</code>	(Optional) Save your entries in the configuration file.

To return to the default map, use the `no mls qos cos-dscp` global configuration command.

This example shows how to modify and display the CoS-to-DSCP map:

```
Switch(config)# mls qos map cos-dscp 10 15 20 25 30 35 40 45
Switch(config)# end
Switch# show mls qos maps cos-dscp

Cos-dscp map:
   cos:   0  1  2  3  4  5  6  7
-----
   dscp:  10 15 20 25 30 35 40 45
```

Configuring the IP-Precedence-to-DSCP Map

You use the IP-precedence-to-DSCP map to map IP precedence values in incoming packets to a DSCP value that QoS uses internally to represent the priority of the traffic.

Table 28-13 shows the default IP-precedence-to-DSCP map:

Table 28-13 Default IP-Precedence-to-DSCP Map

IP Precedence Value	DSCP Value
0	0
1	8
2	16
3	24
4	32
5	40
6	48
7	56

If these values are not appropriate for your network, you need to modify them.

Beginning in privileged EXEC mode, follow these steps to modify the IP-precedence-to-DSCP map. This procedure is optional.

	Command	Purpose
Step 1	configure terminal	Enter global configuration mode.
Step 2	mls qos map ip-prec-dscp <i>dscp1...dscp8</i>	Modify the IP-precedence-to-DSCP map. For <i>dscp1...dscp8</i> , enter eight DSCP values that correspond to the IP precedence values 0 to 7. Separate each DSCP value with a space. The DSCP range is 0 to 63.
Step 3	end	Return to privileged EXEC mode.
Step 4	show mls qos maps ip-prec-dscp	Verify your entries.
Step 5	copy running-config startup-config	(Optional) Save your entries in the configuration file.

To return to the default map, use the **no mls qos ip-prec-dscp** global configuration command.

This example shows how to modify and display the IP-precedence-to-DSCP map:

```
Switch(config)# mls qos map ip-prec-dscp 10 15 20 25 30 35 40 45
Switch(config)# end
Switch# show mls qos maps ip-prec-dscp

IpPrecedence-dscp map:
  ipprec:   0  1  2  3  4  5  6  7
-----
          dscp:  10 15 20 25 30 35 40 45
```

Configuring the Policed-DSCP Map

You use the policed-DSCP map to mark down a DSCP value to a new value as the result of a policing and marking action.

The default policed-DSCP map is a null map, which maps an incoming DSCP value to the same DSCP value.

Beginning in privileged EXEC mode, follow these steps to modify the policed-DSCP map. This procedure is optional.

	Command	Purpose
Step 1	configure terminal	Enter global configuration mode.
Step 2	mls qos map policed-dscp <i>dscp-list</i> to <i>mark-down-dscp</i>	Modify the policed-DSCP map. <ul style="list-style-type: none"> For <i>dscp-list</i>, enter up to eight DSCP values separated by spaces. Then enter the to keyword. For <i>mark-down-dscp</i>, enter the corresponding policed (marked down) DSCP value.
Step 3	end	Return to privileged EXEC mode.
Step 4	show mls qos maps policed-dscp	Verify your entries.
Step 5	copy running-config startup-config	(Optional) Save your entries in the configuration file.

To return to the default map, use the **no mls qos policed-dscp** global configuration command.

This example shows how to map DSCP 50 to 57 to a marked-down DSCP value of 0:

```
Switch(config)# mls qos map policed-dscp 50 51 52 53 54 55 56 57 to 0
Switch(config)# end
Switch# show mls qos maps policed-dscp

Policed-dscp map:
  d1 :  d2 0  1  2  3  4  5  6  7  8  9
-----
  0 :   00 01 02 03 04 05 06 07 08 09
  1 :   10 11 12 13 14 15 16 17 18 19
  2 :   20 21 22 23 24 25 26 27 28 29
  3 :   30 31 32 33 34 35 36 37 38 39
  4 :   40 41 42 43 44 45 46 47 48 49
  5 :   00 00 00 00 00 00 00 00 58 59
  6 :   60 61 62 63
```

**Note**

In this policed-DSCP map, the marked-down DSCP values are shown in the body of the matrix. The d1 column specifies the most-significant digit of the original DSCP; the d2 row specifies the least-significant digit of the original DSCP. The intersection of the d1 and d2 values provides the marked-down value. For example, an original DSCP value of 53 corresponds to a marked-down DSCP value of 0.

Configuring the DSCP-to-CoS Map

You use the DSCP-to-CoS map to generate a CoS value, which is used to select one of the four egress queues.

Table 28-14 shows the default DSCP-to-CoS map.

Table 28-14 Default DSCP-to-CoS Map

DSCP Value	CoS Value
0–7	0
8–15	1
16–23	2
24–31	3
32–39	4
40–47	5
48–55	6
56–63	7

If these values are not appropriate for your network, you need to modify them.

Beginning in privileged EXEC mode, follow these steps to modify the DSCP-to-CoS map. This procedure is optional.

	Command	Purpose
Step 1	configure terminal	Enter global configuration mode.
Step 2	mls qos map dscp-cos <i>dscp-list</i> to <i>cos</i>	Modify the DSCP-to-CoS map. <ul style="list-style-type: none"> For <i>dscp-list</i>, enter up to eight DSCP values separated by spaces. Then enter the to keyword. For <i>cos</i>, enter the CoS value to which the DSCP values correspond. The DSCP range is 0 to 63; the CoS range is 0 to 7.
Step 3	end	Return to privileged EXEC mode.
Step 4	show mls qos maps dscp-to-cos	Verify your entries.
Step 5	copy running-config startup-config	(Optional) Save your entries in the configuration file.

To return to the default map, use the **no mls qos dscp-cos** global configuration command.

This example shows how to map DSCP values 0, 8, 16, 24, 32, 40, 48, and 50 to CoS value 0 and to display the map:

```
Switch(config)# mls qos map dscp-cos 0 8 16 24 32 40 48 50 to 0
Switch(config)# end
Switch# show mls qos maps dscp-cos
Dscp-cos map:
  d1 : d2 0  1  2  3  4  5  6  7  8  9
-----
  0 :   00 00 00 00 00 00 00 00 00 01
  1 :   01 01 01 01 01 01 00 02 02 02
  2 :   02 02 02 02 00 03 03 03 03 03
  3 :   03 03 00 04 04 04 04 04 04 04
  4 :   00 05 05 05 05 05 05 05 00 06
  5 :   00 06 06 06 06 06 07 07 07 07
  6 :   07 07 07 07
```

**Note**

In the above DSCP-to-CoS map, the CoS values are shown in the body of the matrix. The d1 column specifies the most-significant digit of the DSCP; the d2 row specifies the least-significant digit of the DSCP. The intersection of the d1 and d2 values provides the CoS value. For example, in the DSCP-to-CoS map, a DSCP value of 08 corresponds to a CoS value of 0.

Configuring the DSCP-to-DSCP-Mutation Map

If two QoS domains have different DSCP definitions, use the DSCP-to-DSCP-mutation map to translate one set of DSCP values to match the definition of another domain. You apply the DSCP-to-DSCP-mutation map to the receiving port (ingress mutation) at the boundary of a QoS administrative domain.

With ingress mutation, the new DSCP value overwrites the one in the packet, and QoS treats the packet with this new value. The switch sends the packet out the port with the new DSCP value.

You can configure multiple DSCP-to-DSCP-mutation maps on an ingress port. The default DSCP-to-DSCP-mutation map is a null map, which maps an incoming DSCP value to the same DSCP value.

Beginning in privileged EXEC mode, follow these steps to modify the DSCP-to-DSCP-mutation map. This procedure is optional.

	Command	Purpose
Step 1	configure terminal	Enter global configuration mode.
Step 2	mls qos map dscp-mutation <i>dscp-mutation-name in-dscp to out-dscp</i>	Modify the DSCP-to-DSCP-mutation map. <ul style="list-style-type: none"> For <i>dscp-mutation-name</i>, enter the mutation map name. You can create more than one map by specifying a new name. For <i>in-dscp</i>, enter up to eight DSCP values separated by spaces. Then enter the to keyword. For <i>out-dscp</i>, enter a single DSCP value. The DSCP range is 0 to 63.
Step 3	interface interface-id	Specify the port to which to attach the map, and enter interface configuration mode. Valid interfaces include physical ports.

	Command	Purpose
Step 4	mls qos trust dscp	Configure the ingress port as a DSCP-trusted port. By default, the port is not trusted.
Step 5	mls qos dscp-mutation <i>dscp-mutation-name</i>	Apply the map to the specified ingress DSCP-trusted port. For <i>dscp-mutation-name</i> , enter the mutation map name specified in Step 2.
Step 6	end	Return to privileged EXEC mode.
Step 7	show mls qos maps dscp-mutation	Verify your entries.
Step 8	copy running-config startup-config	(Optional) Save your entries in the configuration file.

To return to the default map, use the **no mls qos dscp-mutation** *dscp-mutation-name* global configuration command.

This example shows how to define the DSCP-to-DSCP-mutation map. All the entries that are not explicitly configured are not modified (remains as specified in the null map):

```
Switch(config)# mls qos map dscp-mutation mutation1 1 2 3 4 5 6 7 to 0
Switch(config)# mls qos map dscp-mutation mutation1 8 9 10 11 12 13 to 10
Switch(config)# mls qos map dscp-mutation mutation1 20 21 22 to 20
Switch(config)# mls qos map dscp-mutation mutation1 30 31 32 33 34 to 30
Switch(config)# interface gigabitethernet0/1
Switch(config-if)# mls qos trust dscp
Switch(config-if)# mls qos dscp-mutation mutation1
Switch(config-if)# end
Switch# show mls qos maps dscp-mutation mutation1
Dscp-dscp mutation map:
  mutation1:
    d1 :  d2 0  1  2  3  4  5  6  7  8  9
-----
    0 :    00 00 00 00 00 00 00 00 10 10
    1 :    10 10 10 10 14 15 16 17 18 19
    2 :    20 20 20 23 24 25 26 27 28 29
    3 :    30 30 30 30 30 35 36 37 38 39
    4 :    40 41 42 43 44 45 46 47 48 49
    5 :    50 51 52 53 54 55 56 57 58 59
    6 :    60 61 62 63
```



Note

In the above DSCP-to-DSCP-mutation map, the mutated values are shown in the body of the matrix. The d1 column specifies the most-significant digit of the original DSCP; the d2 row specifies the least-significant digit of the original DSCP. The intersection of the d1 and d2 values provides the mutated value. For example, a DSCP value of 12 corresponds to a mutated value of 10.

Configuring Ingress Queue Characteristics

Depending on the complexity of your network and your QoS solution, you might need to perform all of the tasks in the next sections. You will need to make decisions about these characteristics:

- Which packets are assigned (by DSCP or CoS value) to each queue?
- What drop percentage thresholds apply to each queue, and which CoS or DSCP values map to each threshold?
- How much of the available buffer space is allocated between the queues?

- How much of the available bandwidth is allocated between the queues?
- Is there traffic (such as voice) that should be given high priority?

These sections contain this configuration information:

- [Mapping DSCP or CoS Values to an Ingress Queue and Setting WTD Thresholds, page 28-58](#) (optional)
- [Allocating Buffer Space Between the Ingress Queues, page 28-59](#) (optional)
- [Allocating Bandwidth Between the Ingress Queues, page 28-60](#) (optional)
- [Configuring the Ingress Priority Queue, page 28-61](#) (optional)

Mapping DSCP or CoS Values to an Ingress Queue and Setting WTD Thresholds

You can prioritize traffic by placing packets with particular DSCPs or CoSs into certain queues and adjusting the queue thresholds so that packets with lower priorities are dropped.

Beginning in privileged EXEC mode, follow these steps to map DSCP or CoS values to an ingress queue and to set WTD thresholds. This procedure is optional.

	Command	Purpose
Step 1	configure terminal	Enter global configuration mode.
Step 2	mls qos srr-queue input dscp-map queue <i>queue-id</i> threshold <i>threshold-id</i> <i>dscp1...dscp8</i> or mls qos srr-queue input cos-map queue <i>queue-id</i> threshold <i>threshold-id</i> <i>cos1...cos8</i>	Map DSCP or CoS values to an ingress queue and to a threshold ID. By default, DSCP values 0–39 and 48–63 are mapped to queue 1 and threshold 1. DSCP values 40–47 are mapped to queue 2 and threshold 1. By default, CoS values 0–4, 6, and 7 are mapped to queue 1 and threshold 1. CoS value 5 is mapped to queue 2 and threshold 1. <ul style="list-style-type: none"> • For <i>queue-id</i>, the range is 1 to 2. • For <i>threshold-id</i>, the range is 1 to 3. The drop-threshold percentage for threshold 3 is predefined. It is set to the queue-full state. • For <i>dscp1...dscp8</i>, enter up to eight values, and separate each value with a space. The range is 0 to 63. • For <i>cos1...cos8</i>, enter up to eight values, and separate each value with a space. The range is 0 to 7.
Step 3	mls qos srr-queue input threshold <i>queue-id</i> <i>threshold-percentage1</i> <i>threshold-percentage2</i>	Assign the two WTD threshold percentages for (threshold 1 and 2) to an ingress queue. The default, both thresholds are set to 100 percent. <ul style="list-style-type: none"> • For <i>queue-id</i>, the range is 1 to 2. • For <i>threshold-percentage1 threshold-percentage2</i>, the range is 1 to 100. Separate each value with a space. Each threshold value is a percentage of the total number of queue descriptors allocated for the queue.
Step 4	end	Return to privileged EXEC mode.

	Command	Purpose
Step 5	show mls qos maps	Verify your entries. The DSCP input queue threshold map appears as a matrix. The d1 column specifies the most-significant digit of the DSCP number; the d2 row specifies the least-significant digit in the DSCP number. The intersection of the d1 and the d2 values provides the queue ID and threshold ID; for example, queue 2 and threshold 1 (02-01). The CoS input queue threshold map shows the CoS value in the top row and the corresponding queue ID and threshold ID in the second row; for example, queue 2 and threshold 2 (2-2).
Step 6	copy running-config startup-config	(Optional) Save your entries in the configuration file.

To return to the default CoS input queue threshold map or the default DSCP input queue threshold map, use the **no mls qos srr-queue input cos-map** or the **no mls qos srr-queue input dscp-map** global configuration command. To return to the default WTD threshold percentages, use the **no mls qos srr-queue input threshold *queue-id*** global configuration command.

This example shows how to map DSCP values 0 to 6 to ingress queue 1 and to threshold 1 with a drop threshold of 50 percent. It maps DSCP values 20 to 26 to ingress queue 1 and to threshold 2 with a drop threshold of 70 percent:

```
Switch(config)# mls qos srr-queue input dscp-map queue 1 threshold 1 0 1 2 3 4 5 6
Switch(config)# mls qos srr-queue input dscp-map queue 1 threshold 2 20 21 22 23 24 25 26
Switch(config)# mls qos srr-queue input threshold 1 50 70
```

In this example, the DSCP values (0 to 6) are assigned the WTD threshold of 50 percent and will be dropped sooner than the DSCP values (20 to 26) assigned to the WTD threshold of 70 percent.

Allocating Buffer Space Between the Ingress Queues

You define the ratio (allocate the amount of space) with which to divide the ingress buffers between the two queues. The buffer and the bandwidth allocation control how much data can be buffered before packets are dropped.

Beginning in privileged EXEC mode, follow these steps to allocate the buffers between the ingress queues. This procedure is optional.

	Command	Purpose
Step 1	configure terminal	Enter global configuration mode.
Step 2	mls qos srr-queue input buffers <i>percentage1 percentage2</i>	Allocate the buffers between the ingress queues By default 90 percent of the buffers are allocated to queue 1, and 10 percent of the buffers are allocated to queue 2. For <i>percentage1 percentage2</i> , the range is 0 to 100. Separate each value with a space. You should allocate the buffers so that the queues can handle any incoming bursty traffic.
Step 3	end	Return to privileged EXEC mode.

	Command	Purpose
Step 4	show mls qos interface buffer or show mls qos input-queue	Verify your entries.
Step 5	copy running-config startup-config	(Optional) Save your entries in the configuration file.

To return to the default setting, use the **no mls qos srr-queue input buffers** global configuration command.

This example shows how to allocate 60 percent of the buffer space to ingress queue 1 and 40 percent of the buffer space to ingress queue 2:

```
Switch(config)# mls qos srr-queue input buffers 60 40
```

Allocating Bandwidth Between the Ingress Queues

You need to specify how much of the available bandwidth is allocated between the ingress queues. The ratio of the weights is the ratio of the frequency in which the SRR scheduler sends packets from each queue. The bandwidth and the buffer allocation control how much data can be buffered before packets are dropped. On ingress queues, SRR operates only in shared mode.

Beginning in privileged EXEC mode, follow these steps to allocate bandwidth between the ingress queues. This procedure is optional.

	Command	Purpose
Step 1	configure terminal	Enter global configuration mode.
Step 2	mls qos srr-queue input bandwidth <i>weight1 weight2</i>	Assign shared round robin weights to the ingress queues. The default setting for <i>weight1</i> and <i>weight2</i> is 4 (1/2 of the bandwidth is equally shared between the two queues). For <i>weight1</i> and <i>weight2</i> , the range is 1 to 100. Separate each value with a space. SRR services the priority queue for its configured weight as specified by the bandwidth keyword in the mls qos srr-queue input priority-queue queue-id bandwidth weight global configuration command. Then, SRR shares the remaining bandwidth with both ingress queues and services them as specified by the weights configured with the mls qos srr-queue input bandwidth weight1 weight2 global configuration command. For more information, see the “Configuring the Ingress Priority Queue” section on page 28-61 .
Step 3	end	Return to privileged EXEC mode.
Step 4	show mls qos interface queueing or show mls qos input-queue	Verify your entries.
Step 5	copy running-config startup-config	(Optional) Save your entries in the configuration file.

To return to the default setting, use the **no mls qos srr-queue input bandwidth** global configuration command.

This example shows how to assign the ingress bandwidth to the queues. Priority queueing is disabled, and the shared bandwidth ratio allocated to queue 1 is 25/(25+75) and to queue 2 is 75/(25+75):

```
Switch(config)# mls qos srr-queue input priority-queue 2 bandwidth 0
Switch(config)# mls qos srr-queue input bandwidth 25 75
```

Configuring the Ingress Priority Queue

You should use the priority queue only for traffic that needs to be expedited (for example, voice traffic, which needs minimum delay and jitter).

The priority queue is guaranteed part of the bandwidth to reduce the delay and jitter under heavy network traffic on an oversubscribed ring (when there is more traffic than the backplane can carry, and the queues are full and dropping frames).

SRR services the priority queue for its configured weight as specified by the **bandwidth** keyword in the **mls qos srr-queue input priority-queue *queue-id* bandwidth *weight*** global configuration command. Then, SRR shares the remaining bandwidth with both ingress queues and services them as specified by the weights configured with the **mls qos srr-queue input bandwidth *weight1 weight2*** global configuration command.

Beginning in privileged EXEC mode, follow these steps to configure the priority queue. This procedure is optional.

	Command	Purpose
Step 1	configure terminal	Enter global configuration mode.
Step 2	mls qos srr-queue input priority-queue <i>queue-id</i> bandwidth <i>weight</i>	Assign a queue as the priority queue and guarantee bandwidth on the internal ring if the ring is congested. By default, the priority queue is queue 2, and 10 percent of the bandwidth is allocated to it. <ul style="list-style-type: none"> For <i>queue-id</i>, the range is 1 to 2. For bandwidth <i>weight</i>, assign the bandwidth percentage of the internal ring. The range is 0 to 40. The amount of bandwidth that can be guaranteed is restricted because a large value affects the entire ring and can degrade performance.
Step 3	end	Return to privileged EXEC mode.
Step 4	show mls qos interface queueing or show mls qos input-queue	Verify your entries.
Step 5	copy running-config startup-config	(Optional) Save your entries in the configuration file.

To return to the default setting, use the **no mls qos srr-queue input priority-queue *queue-id*** global configuration command. To disable priority queueing, set the bandwidth weight to 0, for example, **mls qos srr-queue input priority-queue *queue-id* bandwidth 0**.

This example shows how to assign the ingress bandwidths to the queues. Queue 1 is the priority queue with 10 percent of the bandwidth allocated to it. The bandwidth ratios allocated to queues 1 and 2 is 4/(4+4). SRR services queue 1 (the priority queue) first for its configured 10 percent bandwidth. Then SRR equally shares the remaining 90 percent of the bandwidth between queues 1 and 2 by allocating 45 percent to each queue:

```
Switch(config)# mls qos srr-queue input priority-queue 1 bandwidth 10
Switch(config)# mls qos srr-queue input bandwidth 4 4
```

Configuring Egress Queue Characteristics

Depending on the complexity of your network and your QoS solution, you might need to perform all of the tasks in the next sections. You will need to make decisions about these characteristics:

- Which packets are mapped by DSCP or CoS value to each queue and threshold ID?
- What drop percentage thresholds apply to the queue-set (four egress queues per port), and how much reserved and maximum memory is needed for the traffic type?
- How much of the fixed buffer space is allocated to the queue-set?
- Does the bandwidth of the port need to be rate limited?
- How often should the egress queues be serviced and which technique (shaped, shared, or both) should be used?

These sections contain this configuration information:

- [Configuration Guidelines, page 28-62](#)
- [Allocating Buffer Space to and Setting WTD Thresholds for an Egress Queue-Set, page 28-62](#) (optional)
- [Mapping DSCP or CoS Values to an Egress Queue and to a Threshold ID, page 28-65](#) (optional)
- [Configuring SRR Shaped Weights on Egress Queues, page 28-66](#) (optional)
- [Configuring SRR Shared Weights on Egress Queues, page 28-67](#) (optional)
- [Configuring the Egress Expedite Queue, page 28-68](#) (optional)
- [Limiting the Bandwidth on an Egress Interface, page 28-68](#) (optional)

Configuration Guidelines

Follow these guidelines when the expedite queue is enabled or the egress queues are serviced based on their SRR weights:

- If the egress expedite queue is enabled, it overrides the SRR shaped and shared weights for queue 1.
- If the egress expedite queue is disabled and the SRR shaped and shared weights are configured, the shaped mode overrides the shared mode for queue 1, and SRR services this queue in shaped mode.
- If the egress expedite queue is disabled and the SRR shaped weights are not configured, SRR services this queue in shared mode.

Allocating Buffer Space to and Setting WTD Thresholds for an Egress Queue-Set

You can guarantee the availability of buffers, set WTD thresholds, and configure the maximum memory allocation for a queue-set by using the `mls qos queue-set output qset-id threshold queue-id drop-threshold1 drop-threshold2 reserved-threshold maximum-threshold` global configuration command.

Each threshold value is a percentage of the queue's allocated memory, which you specify by using the **mls qos queue-set output *qset-id* buffers *allocation1* ... *allocation4*** global configuration command. The queues use WTD to support distinct drop percentages for different traffic classes.

**Note**

The egress queue default settings are suitable for most situations. You should change them only when you have a thorough understanding of the egress queues and if these settings do not meet your QoS solution.

Beginning in privileged EXEC mode, follow these steps to configure the memory allocation and to drop thresholds for a queue-set. This procedure is optional.

	Command	Purpose
Step 1	configure terminal	Enter global configuration mode.
Step 2	mls qos queue-set output <i>qset-id</i> buffers <i>allocation1</i> ... <i>allocation4</i>	<p>Allocate buffers to a queue-set.</p> <p>By default, all allocation values are equally mapped among the four queues (25, 25, 25, 25). Each queue has 1/4 of the buffer space.</p> <ul style="list-style-type: none"> For <i>qset-id</i>, enter the ID of the queue-set. The range is 1 to 2. Each port belongs to a queue-set, which defines all the characteristics of the four egress queues per port. For <i>allocation1</i> ... <i>allocation4</i>, specify four percentages, one for each queue in the queue-set. For <i>allocation1</i>, <i>allocation3</i>, and <i>allocation4</i>, the range is 0 to 99. For <i>allocation2</i>, the range is 1 to 100 (including the CPU buffer). <p>Allocate buffers according to the importance of the traffic; for example, give a large percentage of the buffer to the queue with the highest-priority traffic.</p>

	Command	Purpose
Step 3	mls qos queue-set output <i>qset-id</i> threshold <i>queue-id drop-threshold1</i> <i>drop-threshold2 reserved-threshold</i> <i>maximum-threshold</i>	<p>Configure the WTD thresholds, guarantee the availability of buffers, and configure the maximum memory allocation for the queue-set (four egress queues per port).</p> <p>By default, the WTD thresholds for queues 1, 3, and 4 are set to 100 percent. The thresholds for queue 2 are set to 200 percent. The reserved thresholds for queues 1, 2, 3, and 4 are set to 50 percent. The maximum thresholds for all queues are set to 400 percent.</p> <ul style="list-style-type: none"> For <i>qset-id</i>, enter the ID of the queue-set specified in Step 2. The range is 1 to 2. For <i>queue-id</i>, enter the specific queue in the queue-set on which the command is performed. The range is 1 to 4. For <i>drop-threshold1 drop-threshold2</i>, specify the two WTD thresholds expressed as a percentage of the queue's allocated memory. The range is 1 to 3200 percent. For <i>reserved-threshold</i>, enter the amount of memory to be guaranteed (reserved) for the queue expressed as a percentage of the allocated memory. The range is 1 to 100 percent. For <i>maximum-threshold</i>, enable a queue in the full condition to obtain more buffers than are reserved for it. This is the maximum memory the queue can have before the packets are dropped if the common pool is not empty. The range is 1 to 3200 percent.
Step 4	interface <i>interface-id</i>	Specify the port of the outbound traffic, and enter interface configuration mode.
Step 5	queue-set <i>qset-id</i>	<p>Map the port to a queue-set.</p> <p>For <i>qset-id</i>, enter the ID of the queue-set specified in Step 2. The range is 1 to 2. The default is 1.</p>
Step 6	end	Return to privileged EXEC mode.
Step 7	show mls qos interface [<i>interface-id</i>] buffers	Verify your entries.
Step 8	copy running-config startup-config	(Optional) Save your entries in the configuration file.

To return to the default setting, use the **no mls qos queue-set output *qset-id* buffers** global configuration command. To return to the default WTD threshold percentages, use the **no mls qos queue-set output *qset-id* threshold [*queue-id*]** global configuration command.

This example shows how to map a port to queue-set 2. It allocates 40 percent of the buffer space to egress queue 1 and 20 percent to egress queues 2, 3, and 4. It configures the drop thresholds for queue 2 to 40 and 60 percent of the allocated memory, guarantees (reserves) 100 percent of the allocated memory, and configures 200 percent as the maximum memory that this queue can have before packets are dropped:

```
Switch(config)# mls qos queue-set output 2 buffers 40 20 20 20
Switch(config)# mls qos queue-set output 2 threshold 2 40 60 100 200
Switch(config)# interface gigabitethernet0/1
Switch(config-if)# queue-set 2
```

Mapping DSCP or CoS Values to an Egress Queue and to a Threshold ID

You can prioritize traffic by placing packets with particular DSCPs or costs of service into certain queues and adjusting the queue thresholds so that packets with lower priorities are dropped.



Note

The egress queue default settings are suitable for most situations. You should change them only when you have a thorough understanding of the egress queues and if these settings do not meet your QoS solution.

Beginning in privileged EXEC mode, follow these steps to map DSCP or CoS values to an egress queue and to a threshold ID. This procedure is optional.

	Command	Purpose
Step 1	configure terminal	Enter global configuration mode.
Step 2	mls qos srr-queue output dscp-map queue <i>queue-id</i> threshold <i>threshold-id</i> <i>dscp1...dscp8</i> or mls qos srr-queue output cos-map queue <i>queue-id</i> threshold <i>threshold-id</i> <i>cos1...cos8</i>	Map DSCP or CoS values to an egress queue and to a threshold ID. By default, DSCP values 0–15 are mapped to queue 2 and threshold 1. DSCP values 16–31 are mapped to queue 3 and threshold 1. DSCP values 32–39 and 48–63 are mapped to queue 4 and threshold 1. DSCP values 40–47 are mapped to queue 1 and threshold 1. By default, CoS values 0 and 1 are mapped to queue 2 and threshold 1. CoS values 2 and 3 are mapped to queue 3 and threshold 1. CoS values 4, 6, and 7 are mapped to queue 4 and threshold 1. CoS value 5 is mapped to queue 1 and threshold 1. <ul style="list-style-type: none"> For <i>queue-id</i>, the range is 1 to 4. For <i>threshold-id</i>, the range is 1 to 3. The drop-threshold percentage for threshold 3 is predefined. It is set to the queue-full state. For <i>dscp1...dscp8</i>, enter up to eight values, and separate each value with a space. The range is 0 to 63. For <i>cos1...cos8</i>, enter up to eight values, and separate each value with a space. The range is 0 to 7.
Step 3	end	Return to privileged EXEC mode.
Step 4	show mls qos maps	Verify your entries. The DSCP output queue threshold map appears as a matrix. The d1 column specifies the most-significant digit of the DSCP number; the d2 row specifies the least-significant digit in the DSCP number. The intersection of the d1 and the d2 values provides the queue ID and threshold ID; for example, queue 2 and threshold 1 (02-01). The CoS output queue threshold map shows the CoS value in the top row and the corresponding queue ID and threshold ID in the second row; for example, queue 2 and threshold 2 (2-2).
Step 5	copy running-config startup-config	(Optional) Save your entries in the configuration file.

To return to the default DSCP output queue threshold map or the default CoS output queue threshold map, use the **no mls qos srr-queue output dscp-map** or the **no mls qos srr-queue output cos-map** global configuration command.

This example shows how to map DSCP values 10 and 11 to egress queue 1 and to threshold 2:

```
Switch(config)# mls qos srr-queue output dscp-map queue 1 threshold 2 10 11
```

Configuring SRR Shaped Weights on Egress Queues

You can specify how much of the available bandwidth is allocated to each queue. The ratio of the weights is the ratio of frequency in which the SRR scheduler sends packets from each queue.

You can configure the egress queues for shaped or shared weights, or both. Use shaping to smooth bursty traffic or to provide a smoother output over time. For information about shaped weights, see the “[SRR Shaping and Sharing](#)” section on page 28-13. For information about shared weights, see the “[Configuring SRR Shared Weights on Egress Queues](#)” section on page 28-67.

Beginning in privileged EXEC mode, follow these steps to assign the shaped weights and to enable bandwidth shaping on the four egress queues mapped to a port. This procedure is optional.

	Command	Purpose
Step 1	configure terminal	Enter global configuration mode.
Step 2	interface <i>interface-id</i>	Specify the port of the outbound traffic, and enter interface configuration mode.
Step 3	srr-queue bandwidth shape <i>weight1 weight2 weight3 weight4</i>	Assign SRR weights to the egress queues. By default, <i>weight1</i> is set to 25; <i>weight2</i> , <i>weight3</i> , and <i>weight4</i> are set to 0, and these queues are in shared mode. For <i>weight1 weight2 weight3 weight4</i> , enter the weights to control the percentage of the port that is shaped. The inverse ratio ($1/\textit{weight}$) controls the shaping bandwidth for this queue. Separate each value with a space. The range is 0 to 65535. If you configure a weight of 0, the corresponding queue operates in shared mode. The weight specified with the srr-queue bandwidth shape command is ignored, and the weights specified with the srr-queue bandwidth share interface configuration command for a queue come into effect. When configuring queues in the same queue-set for both shaping and sharing, make sure that you configure the lowest number queue for shaping. The shaped mode overrides the shared mode.
Step 4	end	Return to privileged EXEC mode.
Step 5	show mls qos interface <i>interface-id</i> queueing	Verify your entries.
Step 6	copy running-config startup-config	(Optional) Save your entries in the configuration file.

To return to the default setting, use the **no srr-queue bandwidth shape** interface configuration command.

This example shows how to configure bandwidth shaping on queue 1. Because the weight ratios for queues 2, 3, and 4 are set to 0, these queues operate in shared mode. The bandwidth weight for queue 1 is 1/8, which is 12.5 percent:

```
Switch(config)# interface gigabitethernet0/1
Switch(config-if)# srr-queue bandwidth shape 8 0 0 0
```

Configuring SRR Shared Weights on Egress Queues

In shared mode, the queues share the bandwidth among them according to the configured weights. The bandwidth is guaranteed at this level but not limited to it. For example, if a queue empties and does not require a share of the link, the remaining queues can expand into the unused bandwidth and share it among them. With sharing, the ratio of the weights controls the frequency of dequeuing; the absolute values are meaningless.



Note

The egress queue default settings are suitable for most situations. You should change them only when you have a thorough understanding of the egress queues and if these settings do not meet your QoS solution.

Beginning in privileged EXEC mode, follow these steps to assign the shared weights and to enable bandwidth sharing on the four egress queues mapped to a port. This procedure is optional.

	Command	Purpose
Step 1	configure terminal	Enter global configuration mode.
Step 2	interface <i>interface-id</i>	Specify the port of the outbound traffic, and enter interface configuration mode.
Step 3	srr-queue bandwidth share <i>weight1 weight2 weight3 weight4</i>	Assign SRR weights to the egress queues. By default, all four weights are 25 (1/4 of the bandwidth is allocated to each queue). For <i>weight1 weight2 weight3 weight4</i> , enter the weights to control the ratio of the frequency in which the SRR scheduler sends packets. Separate each value with a space. The range is 1 to 255.
Step 4	end	Return to privileged EXEC mode.
Step 5	show mls qos interface <i>interface-id</i> queueing	Verify your entries.
Step 6	copy running-config startup-config	(Optional) Save your entries in the configuration file.

To return to the default setting, use the **no srr-queue bandwidth share** interface configuration command.

This example shows how to configure the weight ratio of the SRR scheduler running on an egress port. Four queues are used, and the bandwidth ratio allocated for each queue in shared mode is $1/(1+2+3+4)$, $2/(1+2+3+4)$, $3/(1+2+3+4)$, and $4/(1+2+3+4)$, which is 10 percent, 20 percent, 30 percent, and 40 percent for queues 1, 2, 3, and 4. This means that queue 4 has four times the bandwidth of queue 1, twice the bandwidth of queue 2, and one-and-a-third times the bandwidth of queue 3.

```
Switch(config)# interface gigabitethernet0/1
Switch(config-if)# srr-queue bandwidth share 1 2 3 4
```

Configuring the Egress Expedite Queue

Beginning in Cisco IOS Release 12.1(19)EA1, You can ensure that certain packets have priority over all others by queuing them in the egress expedite queue. SRR services this queue until it is empty before servicing the other queues.

Beginning in privileged EXEC mode, follow these steps to enable the egress expedite queue. This procedure is optional.

	Command	Purpose
Step 1	configure terminal	Enter global configuration mode.
Step 2	mls qos	Enable QoS on a switch.
Step 3	interface <i>interface-id</i>	Specify the egress port, and enter interface configuration mode.
Step 4	priority-queue out	Enable the egress expedite queue, which is disabled by default. When you configure this command, the SRR weight and queue size ratios are affected because there is one less queue participating in SRR. This means that <i>weight1</i> in the srr-queue bandwidth shape or the srr-queue bandwidth share command is ignored (not used in the ratio calculation).
Step 5	end	Return to privileged EXEC mode.
Step 6	show running-config	Verify your entries.
Step 7	copy running-config startup-config	(Optional) Save your entries in the configuration file.

To disable the egress expedite queue, use the **no priority-queue out** interface configuration command.

This example shows how to enable the egress expedite queue when the SRR weights are configured. The egress expedite queue overrides the configured SRR weights.

```
Switch(config)# interface gigabitethernet0/1
Switch(config-if)# srr-queue bandwidth shape 25 0 0 0
Switch(config-if)# srr-queue bandwidth share 30 20 25 25
Switch(config-if)# priority-queue out
Switch(config-if)# end
```

Limiting the Bandwidth on an Egress Interface

You can limit the bandwidth on an egress port. For example, if a customer pays only for a small percentage of a high-speed link, you can limit the bandwidth to that amount.



Note

The egress queue default settings are suitable for most situations. You should change them only when you have a thorough understanding of the egress queues and if these settings do not meet your QoS solution.

Beginning in privileged EXEC mode, follow these steps to limit the bandwidth on an egress port. This procedure is optional.

	Command	Purpose
Step 1	configure terminal	Enter global configuration mode.
Step 2	interface <i>interface-id</i>	Specify the port to be rate limited, and enter interface configuration mode.

	Command	Purpose
Step 3	srr-queue bandwidth limit <i>weight1</i>	Specify the percentage of the port speed to which the port should be limited. The range is 10 to 90. By default, the port is not rate limited and is set to 100 percent.
Step 4	end	Return to privileged EXEC mode.
Step 5	show mls qos interface [<i>interface-id</i>] queueing	Verify your entries.
Step 6	copy running-config startup-config	(Optional) Save your entries in the configuration file.

To return to the default setting, use the **no srr-queue bandwidth limit** interface configuration command.

This example shows how to limit the bandwidth on a port to 80 percent:

```
Switch(config)# interface gigabitethernet0/1
Switch(config-if)# srr-queue bandwidth limit 80
```

When you configure this command to 80 percent, the port is idle 20 percent of the time. The line rate drops to 80 percent of the connected speed, which is 800 Mb/s. These values are not exact because the hardware adjusts the line rate in increments of six.

Displaying Standard QoS Information

To display standard QoS information, use one or more of the privileged EXEC commands in [Table 28-15](#):

Table 28-15 Commands for Displaying Standard QoS Information

Command	Purpose
show class-map [<i>class-map-name</i>]	Display QoS class maps, which define the match criteria to classify traffic.
show mls qos	Display global QoS configuration information.
show mls qos aggregate-policer [<i>aggregate-policer-name</i>]	Display the aggregate policer configuration.
show mls qos input-queue	Display QoS settings for the ingress queues.
show mls qos interface [<i>interface-id</i>] [buffers policers queueing statistics]	Display QoS information at the port level, including the buffer allocation, which ports have configured policers, the queueing strategy, and the ingress and egress statistics.
show mls qos maps [cos-dscp cos-input-q cos-output-q dscp-cos dscp-input-q dscp-mutation <i>dscp-mutation-name</i> dscp-output-q ip-prec-dscp policed-dscp]	Display QoS mapping information.
show mls qos queue-set [<i>qset-id</i>]	Display QoS settings for the egress queues.

Table 28-15 *Commands for Displaying Standard QoS Information (continued)*

Command	Purpose
show policy-map [<i>policy-map-name</i> [class <i>class-map-name</i>]]	Display QoS policy maps, which define classification criteria for incoming traffic. Note Do not use the show policy-map interface privileged EXEC command to display classification information for incoming traffic. The control-plane and interface keywords are not supported, and the statistics shown in the display should be ignored.
show running-config include rewrite	Display the DSCP transparency setting.



CHAPTER 29

Configuring IPv6 Host Functions

Internet Protocol Version 6 (IPv6) is the network-layer Internet Protocol intended to replace Version 4 (IPv4) in the TCP/IP suite of protocols. This chapter describes how to configure IPv6 host functions on the Catalyst 2960 switch.

For information about configuring IPv6 Multicast Listener Discovery (MLD) snooping, see [Chapter 30, “Configuring IPv6 MLD Snooping.”](#)

To enable dual stack environments (supporting both IPv4 and IPv6), you must configure a switch database management (SDM) template to a dual IPv4 and IPv6 template. See the [“SDM Templates” section on page 29-6.](#)



Note

For complete syntax and usage information for the commands used in this chapter, see the Cisco IOS documentation referenced in the procedures

This chapter consists of these sections:

- [“Understanding IPv6” section on page 29-1](#)
- [“Configuring IPv6” section on page 29-7](#)
- [“Displaying IPv6” section on page 29-11](#)

Understanding IPv6

The primary reason for using IPv6 is to increase Internet global address space to accommodate the rapidly increasing number of users and applications that require unique global IP addresses. IPv4 uses 32-bit addresses to provide approximately 4 billion available addresses. Large blocks of these addresses are allocated to government agencies and large organizations, and the number of available IP addresses is rapidly decreasing. IPv6 incorporates 128-bit source and destination addresses and can provide significantly more globally unique IP addresses than IPv4.

The architecture of IPv6 allows existing IPv4 users to transition easily to IPv6, and provides services such as end-to-end security, quality of service (QoS), and globally unique addresses. The flexibility of the IPv6 address space reduces the need for private addresses and the use of Network Address Translation (NAT) processing by border routers at the edge of networks. IPv6 provides newer unicast methods, introduces hexadecimal values into the IP address, and uses colons (:) instead of periods (.) as delimiters.

IPv6 also provides these advantages over IPv4:

- Easier address management and delegation
- Easy address autoconfiguration with *stateless autoconfiguration*, which is similar to DHCP but does not require a specified DHCP application or server
- Embedded IPsec (encrypted security)
- Routing optimized for mobile devices
- Duplicate Address Detection (DAD) feature

For information about how Cisco Systems implements IPv6, go to this URL:

<http://www.cisco.com/warp/public/732/Tech/ipv6/>

This section describes IPv6 implementation on the switch. These sections are included:

- [IPv6 Addresses, page 29-2](#)
- [Supported IPv6 Unicast Routing Features, page 29-3](#)
- [SDM Templates, page 29-6](#)

IPv6 Addresses

IPv6 supports three types of addresses: unicast (one-to-one), multicast (one-to-many), and anycast (one-to-nearest). Multicast addresses replace the use of broadcast addresses. The switch supports only IPv6 unicast addresses. The switch does not support site-local unicast addresses, anycast addresses, or multicast addresses in this release.

The IPv6 128-bit addresses are represented as a series of eight 16-bit hexadecimal fields separated by colons in the format: x:x:x:x:x:x:x. This is an example of an IPv6 address:

```
2031:0000:130F:0000:0000:09C0:080F:130B
```

For easier implementation, leading zeros in each field are optional. This is the same address without leading zeros:

```
2031:0:130F:0:0:9C0:80F:130B
```

You can also use two colons (::) to represent successive hexadecimal fields of zeros, but you can use this short version only once in each address:

```
2031:0:130F::09C0:080F:130B
```

For more information about IPv6 address formats, address types, and the IPv6 packet header, go to the “Implementing Addressing and Basic Connectivity” section of “The Cisco IOS IPv6 Configuration Library” at this URL:

http://www.cisco.com/en/US/products/sw/iosswrel/ps1839/products_feature_guide09186a00807fcf4b.html

In the “Implementing Addressing and Basic Connectivity” chapter, these sections apply to the Catalyst 2960 switch:

- IPv6 Address Formats
- IPv6 Address Output Display
- Simplified IPv6 Packet Header

Supported IPv6 Unicast Routing Features

These sections describe the IPv6 protocol (RFC 2460) features supported by the switch:

- [128-Bit Wide Unicast Addresses, page 29-3](#)
- [ICMPv6, page 29-4](#)
- [Neighbor Discovery, page 29-4](#)
- [IPv6 Stateless Autoconfiguration and Duplicate Address Detection, page 29-4](#)
- [IPv6 Applications, page 29-5](#)
- [Dual IPv4 and IPv6 Protocol Stacks, page 29-5](#)

Support on the switch includes expanded address capability, header format simplification, improved support of extensions and options, and hardware parsing of the extension header. The switch supports hop-by-hop extension header packets, which are routed or bridged in software.

128-Bit Wide Unicast Addresses

The switch supports aggregatable global unicast addresses and link-local unicast addresses (RFC 2373). It does not support site-local unicast addresses.

- Aggregatable global unicast addresses are IPv6 addresses from the aggregatable global unicast prefix. The address structure enables strict aggregation of routing prefixes and limits the number of routing table entries in the global routing table. These addresses are used on links that are aggregated through organizations and eventually to the Internet service provider.

These addresses are defined by a global routing prefix, a subnet ID, and an interface ID. Current global unicast address allocation uses the range of addresses that start with binary value 001 (2000::/3). Addresses with a prefix of 2000::/3(001) through E000::/3(111) must have 64-bit interface identifiers in the extended universal identifier (EUI)-64 format.

- Link local unicast addresses can be automatically configured on any interface by using the link-local prefix FE80::/10(1111 1110 10) and the interface identifier in the modified EUI format. Link-local addresses are used in the neighbor discovery protocol and the stateless autoconfiguration process. Nodes on a local link use link-local addresses and do not require globally unique addresses to communicate. IPv6 routers do not forward packets with link-local source or destination addresses to other links.

See the section on IPv6 Unicast Addresses in the “Implementing Addressing and Basic Connectivity for IPv6” chapter in the *Cisco IOS IPv6 Configuration Library* at this URL:

http://www.cisco.com/en/US/products/sw/iosswrel/ps1839/products_feature_guide09186a00807fcf4b.html

Each IPv6 host interface can support up to three addresses in hardware (one aggregatable global unicast address, one link-local unicast address, and zero or more privacy addresses).

DNS for IPv6

IPv6 introduces new Domain Name System (DNS) record types that are supported in the DNS name-to-address and address-to-name lookup processes. The new DNS AAAA resource record types support IPv6 addresses and are equivalent to an A address record in IPv4. The switch supports DNS resolution for IPv4 and IPv6.

ICMPv6

The Internet Control Message Protocol (ICMP) in IPv6 (RFC 2463) functions the same as in IPv4. ICMP generates error messages, such as ICMP destination unreachable messages, to report errors during processing and other diagnostic functions. In IPv6, ICMP packets are also used in the neighbor discovery protocol and path MTU discovery. A value of 58 in the Next Header field of the basic IPv6 packet header identifies an IPv6 ICMP packet.

Neighbor Discovery

The switch supports Neighbor Discovery Protocol (NDP) for IPv6 (RFC 2461), a protocol running on top of ICMPv6, and Static Neighbor Discovery for IPv6 stations that do not support NDP. The IPv6 neighbor discovery process uses ICMP messages and solicited-node multicast addresses to determine the link-layer address of a neighbor on the same network (local link), verify the reachability of the neighbor, and keep track of neighboring routers.

A value of 135 in the Type field of the ICMP packet header identifies a neighbor solicitation message. These messages are sent on the local link when a node needs to determine the link-layer address of another node on the same local link. When a destination node receives a neighbor solicitation message, it replies by sending a neighbor advertisement message, which has a value of 136 in the ICMP packet header Type field.

A value of 137 in the ICMP packet header Type field identifies an IPv6 neighbor redirect message. The switch supports ICMPv6 redirect (RFC 2463) for routes with mask lengths less than 64. ICMP redirect is not supported for host routes or for summarized routes with mask lengths greater than 64. Routers send neighbor-redirect messages to inform hosts of better first-hop nodes on the path to a destination. A router does not update its routing tables after receiving a neighbor-redirect message and hosts do not originate neighbor-redirect messages.

Neighbor discovery throttling ensures that the switch CPU is not unnecessarily burdened while it is in the process of obtaining the next hop forwarding information to route an IPv6 packet. The switch performs a drop in hardware of any additional IPv6 packets whose next hop is the same neighbor the CPU is actively resolving. Performing this drop avoids adding further load on the CPU and results in a more efficient use of the switch CPU in an IPv6 routed environment.

IPv6 Stateless Autoconfiguration and Duplicate Address Detection

IPv6 supports two types of autoconfiguration:

- Stateless autoconfiguration (RFC 2462), where a host autonomously configures its own link-local address, and booting nodes send router solicitations to request router advertisements for configuring interfaces
- Stateful autoconfiguration using Dynamic Host Configuration Protocol (DHCP) v6.

The switch supports stateless autoconfiguration to manage link, subnet, and site addressing changes, such as management of host and mobile IP addresses.

All interfaces on IPv6 nodes must have a link-local address, which is automatically configured from the identifier (router MAC address) for an interface and the link-local prefix FE80::/10. A link-local address enables a node to communicate with other nodes on the link and can be used to further configure the node. Nodes can connect to a network and automatically generate global IPv6 addresses without the need for manual configuration or the help of a server, such as a DHCP server. With IPv6, a router on the link uses router advertisement messages to advertise global prefixes and its ability to act as a default router for the link. A node on the link can automatically configure global IPv6 addresses by appending its interface identifier (64-bits) to the prefixes (64 bits) included in the router advertisement messages.

The 128-bit IPv6 addresses configured by a node are then subjected to duplicate-address detection (RFC 2462) to ensure their uniqueness on the link. If the advertised prefixes are globally unique, the IPv6 addresses configured by the node are guaranteed to be globally unique. Router solicitation messages, which have a value of 133 in the ICMP packet header Type field, are sent by hosts at system startup so that the host can be immediately autoconfigured without waiting for the next scheduled router advertisement message. IPv6 duplicate-address detection is performed on unicast addresses before they are assigned to an interface. The switch does not support automatically generated site-local IPv6 addresses.

IPv6 Applications

The switch has IPv6 support for these applications:

- Ping, traceroute, Telnet, TFTP, and FTP
- Secure Shell (SSH) over an IPv6 transport
- HTTP server access over IPv6 transport
- DNS resolver for AAAA over IPv4 transport
- Cisco Discovery Protocol (CDP) support for IPv6 addresses

For more information about managing these applications with Cisco IOS, see the “Managing Cisco IOS Applications over IPv6” section in the *Cisco IOS IPv6 Configuration Library* at this URL:

http://www.cisco.com/en/US/products/sw/iosswrel/ps1839/products_feature_guide09186a00807fcf4b.html

Dual IPv4 and IPv6 Protocol Stacks

One technique for transitioning to IPv6 is by using dual IPv4 and IPv6 protocol stacks. Using dual stacks enables gradual, one-by-one upgrades to applications running on nodes. Applications that are upgraded to IPv6 use the IPv6 protocol stack, and applications that are not upgraded and support only IPv4 can coexist with upgraded applications on the same node. New and upgraded applications can use both IPv4 and IPv6 protocol stacks.

The Cisco IOS software supports the dual IPv4 and IPv6 protocol stack technique. When both IPv4 and IPv6 routing are enabled and an interface is configured with both an IPv4 and IPv6 address, the interface forwards both IPv4 and IPv6 traffic.

Figure 29-1 shows a router forwarding both IPv4 and IPv6 traffic through the same interface, based on the IP packet and destination addresses.

Figure 29-1 Dual IPv4 and IPv6 Support on an Interface

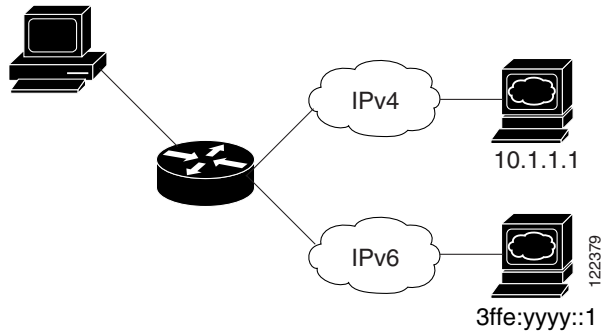

The switch uses ternary content addressable memory (TCAM) to store unicast routes, MAC addresses, access control lists (ACLs), and other features, and provides the switch database management (SDM) templates to allocate memory resources depending on how the switch is used. You must use the dual IPv4 and IPv6 template templates to allocate TCAM usage to both IPv4 and IPv6 protocols. See the “[SDM Templates](#)” section on page 29-6.

SDM Templates

Catalyst 2960 switches have one TCAM to store unicast routes, MAC addresses, ACLs, and other features. To allocate TCAM resources for different usages, the switch SDM templates prioritize system resources to optimize support for certain features. You select the template that best suits the switch environment by entering the **sdm prefer** global configuration command. For more information about SDM templates, see [Chapter 7, “Configuring SDM Templates.”](#)

The dual IPv4 and IPv6 templates allow the switch to be used in dual stack environments (supporting both IPv4 and IPv6).



Note

If you try to configure IPv6 without first selecting a dual IPv4 and IPv6 template, a warning message is generated.

- In IPv4-only environments, the switch applies IPv4 QoS and ACLs in hardware. IPv6 packets are not supported.
- In dual IPv4 and IPv6 environments, the switch applies IPv4 QoS and ACLs in hardware.



Note

If you do not plan to use IPv6, do not use the dual stack template because this template results in less TCAM capacity for each resource.

Dual IPv4-and-IPv6 SDM Templates

These SDM templates support IPv4 and IPv6 environments:

Note

This release does not support IPv6 multicast routing or QoS. This release does support IPv6 Multicast Listener Discovery (MLD) snooping.

- Dual IPv4 and IPv6 default SDM template—supports Layer 2, QoS, and ACLs for IPv4; and Layer 2 and ACLs for IPv6 on the switch.

Note

An IPv4 route requires only one TCAM entry. Because of the hardware compression scheme used for IPv6, an IPv6 route can take more than one TCAM entry, reducing the number of entries forwarded in hardware.

Table 29-1 defines the approximate feature resources allocated by each new template.

Table 29-1 Approximate Number of Feature Resources Allowed by Each Template

Resource	Default	QoS	Dual
Unicast MAC addresses	8 K	8 K	8 K
IPv4 IGMP groups + multicast routes	.25 K	.25 K	.25 K
IPv4 unicast routes	0	0	0
IPv6 multicast groups	0	0	.25 K
Directly connected IPv6 addresses	0	0	0
Indirect IPv6 unicast routes	0	0	0
IPv4 policy-based routing aces	0	0	0
IPv4 MAC QoS ACEs	128	384	.25 K
IPv4 MAC security ACEs	384	128	.25 K
IPv6 policy-based routing aces	0	0	0
IPv4 MAC QoS ACEs	0	0	0
IPv4 MAC security ACEs	0	0	0

Configuring IPv6

These sections contain this IPv6 forwarding configuration information:

- [Default IPv6 Configuration, page 29-8](#)
- [Configuring IPv6 ICMP Rate Limiting, page 29-8](#)
- [Configuring Static Routes for IPv6, page 29-9](#)

Default IPv6 Configuration

Table 29-2 shows the default IPv6 configuration.

Table 29-2 Default IPv6 Configuration

Feature	Default Setting
SDM template	Default
IPv6 addresses	None configured

Configuring IPv6 ICMP Rate Limiting

IPv6 ICMP rate limiting uses a token-bucket algorithm for limiting the rate at which IPv6 ICMP error messages are sent to the network. The interval between error messages is specified in a time interval and a bucket size. Because some applications, such as traceroute, sometimes require replies to a group of requests to be sent out in rapid succession, specifying only the interval between error messages can cause the application to fail. The token bucket allows a number of tokens, each representing the ability to send one error message, to be stored in virtual buckets. For every message to be sent, one token is removed from the bucket. If a series of error messages is generated, error messages can be sent until the bucket is empty. When the bucket is empty, IPv6 ICMP error messages are not sent until a new token is placed in the bucket. This method does not increase the average rate-limiting time interval, but it provides more flexibility than fixed-time intervals.

ICMP rate limiting is enabled by default with a default interval between error messages of 100 milliseconds and a bucket size (maximum number of tokens to be stored in a bucket) of 10.

Beginning in privileged EXEC mode, follow these steps to change the ICMP rate-limiting parameters:

	Command	Purpose
Step 1	configure terminal	Enter global configuration mode.
Step 2	ipv6 icmp error-interval <i>interval</i> [<i>bucketsize</i>]	Configure the interval and bucket size for IPv6 ICMP error messages: <ul style="list-style-type: none"> <i>interval</i>—The interval (in milliseconds) between tokens being added to the bucket. The range is from 0 to 2147483647 milliseconds. <i>bucketsize</i>—(Optional) The maximum number of tokens stored in the bucket. The range is from 1 to 200.
Step 3	end	Return to privileged EXEC mode.
Step 4	show ipv6 interface [<i>interface-id</i>]	Verify your entries.
Step 5	copy running-config startup-config	(Optional) Save your entries in the configuration file.

To return to the default configuration, use the **no ipv6 icmp error-interval** global configuration command.

This example shows how to configure an IPv6 ICMP error message interval of 50 milliseconds and a bucket size of 20 tokens.

```
Switch(config)#ipv6 icmp error-interval 50 20
```

Configuring Static Routes for IPv6

Static routes are manually configured and define an explicit route between two networking devices. The benefits of static routes include security and resource efficiency. Static routes use less bandwidth than dynamic routing protocols because there is no requirement for routes to be calculated and communicated. The main disadvantage of using static routes is that static routes are not automatically updated, as with a dynamic routing protocol, and must be manually reconfigured if the network topology changes. Static routes are useful for smaller networks with only one path to an outside network or to provide security for a larger network for certain types of traffic.

There are types of static routes:

- Directly attached static routes—Only the output interface is specified because the destination is assumed to be directly attached to this interface. The packet destination is used as the next hop address. A directly attached static route is valid only when the specified interface is IPv6-enabled and is up.
- Recursive static routes—Only the next hop is specified, and the output interface is derived from the next hop. A recursive static route is valid only when the specified next hop results in a valid IPv6 output interface, the route does not self-recur, and the recursion depth does not exceed the maximum IPv6 forwarding recursion depth.
- Fully specified static routes—Both the output interface and the next hop are specified. The next hop is assumed to be directly attached to the specified output interface. A fully specified route is valid when the specified IPv6 interface is IPv6-enabled and up.
- Floating static routes—Any of the three types of static routes can be floating static routes, used to back up dynamic routes learned through configured routing protocols. A floating static route is configured with a less efficient administrative distance than the routing protocol it is backing up. Therefore, the dynamic route is always used for routing traffic in preference to the floating static route. If the dynamic route is lost, the floating static route is used in its place.

Beginning in privileged EXEC mode, follow these steps to configure an IPv6 static route:

	Command	Purpose
Step 1	configure terminal	Enter global configuration mode.
Step 2	ipv6 route <i>ipv6-prefix/prefix length</i> { <i>ipv6-address</i> <i>interface-id</i> [<i>ipv6-address</i>]} [<i>administrative distance</i>]	<p>Configure a static IPv6 route.</p> <ul style="list-style-type: none"> • <i>ipv6-prefix</i>—The IPv6 network that is the destination of the static route. It can also be a hostname when static host routes are configured. • <i>/prefix length</i>—The length of the IPv6 prefix. A decimal value that shows how many of the high-order contiguous bits of the address comprise the prefix (the network portion of the address). A slash mark must precede the decimal value. • <i>ipv6-address</i>—The IPv6 address of the next hop that can be used to reach the specified network. The IPv6 address of the next hop need not be directly connected; recursion is done to find the IPv6 address of the directly connected next hop. The address must be in the form documented in RFC 2373, specified in hexadecimal using 16-bit values between colons. • <i>interface-id</i>—Specify direct static routes from point-to-point and broadcast interfaces. With point-to-point interfaces, there is no need to specify the IPv6 address of the next hop. With broadcast interfaces, you should always specify the IPv6 address of the next hop, or ensure that the specified prefix is assigned to the link, specifying a link-local address as the next hop. You can optionally specify the IPv6 address of the next hop to which packets are sent. <p>Note You must specify an <i>interface-id</i> when using a link-local address as the next hop (the link-local next hop must also be an adjacent router).</p> <ul style="list-style-type: none"> • <i>administrative distance</i>—(Optional) An administrative distance. The range is 1 to 254; the default value is 1, which gives static routes precedence over any other type of route except connected routes. To configure a floating static route, use an administrative distance greater than that of the dynamic routing protocol.
Step 3	end	Return to privileged EXEC mode.

	Command	Purpose
Step 4	<p>show ipv6 static [<i>ipv6-address</i> <i>ipv6-prefix/prefix length</i>] [interface <i>interface-id</i>] [recursive] [detail]</p> <p>or</p> <p>show ipv6 route static [<i>updated</i>]</p>	<p>Verify your entries by displaying the contents of the IPv6 routing table.</p> <ul style="list-style-type: none"> • interface <i>interface-id</i>—(Optional) Display only those static routes with the specified interface as an egress interface. • recursive—(Optional) Display only recursive static routes. The recursive keyword is mutually exclusive with the interface keyword, but it can be used with or without the IPv6 prefix included in the command syntax. • detail—(Optional) Display this additional information: <ul style="list-style-type: none"> – For valid recursive routes, the output path set, and maximum resolution depth. – For invalid routes, the reason why the route is not valid.
Step 5	copy running-config startup-config	(Optional) Save your entries in the configuration file.

To remove a configured static route, use the **no ipv6 route** *ipv6-prefix/prefix length* {*ipv6-address* | *interface-id* [*ipv6-address*]} [*administrative distance*] global configuration command.

This example shows how to configure a floating static route to an interface with an administrative distance of 130:

```
Switch(config)# ipv6 route 2001:0DB8::/32 gigabitethernet0/1 130
```

For more information about configuring static IPv6 routing, see the “Implementing Static Routes for IPv6” chapter in the *Cisco IOS IPv6 Configuration Library* at this URL:

http://www.cisco.com/en/US/products/sw/iosswrel/ps1839/products_feature_guide09186a00807fcf4b.html

Displaying IPv6

Table 29-3 shows the privileged EXEC commands for monitoring IPv6 on the switch.

Table 29-3 Commands for Monitoring IPv6

Command	Purpose
show ipv6 access-list	Display a summary of access lists.
show ipv6 interface <i>interface-id</i>	Display IPv6 interface status and configuration.
show ipv6 mtu	Display IPv6 MTU per destination cache.
show ipv6 neighbors	Display IPv6 neighbor cache entries.
show ipv6 prefix-list	Display a list of IPv6 prefix lists.
show ipv6 protocols	Display IPv6 routing protocols on the switch.
show ipv6 route	Display the IPv6 route table entries.
show ipv6 static	Display IPv6 static routes.
show ipv6 traffic	Display IPv6 traffic statistics.

This is an example of the output from the **show ipv6 interface** privileged EXEC command:

```
Switch# show ipv6 interface
Vlan1 is up, line protocol is up
  IPv6 is enabled, link-local address is FE80::20B:46FF:FE2F:D940
  Global unicast address(es):
    3FFE:C000:0:1:20B:46FF:FE2F:D940, subnet is 3FFE:C000:0:1::/64 [EUI]
  Joined group address(es):
    FF02::1
    FF02::2
    FF02::1:FF2F:D940
  MTU is 1500 bytes
  ICMP error messages limited to one every 100 milliseconds
  ICMP redirects are enabled
  ND DAD is enabled, number of DAD attempts: 1
  ND reachable time is 30000 milliseconds
  ND advertised reachable time is 0 milliseconds
  ND advertised retransmit interval is 0 milliseconds
  ND router advertisements are sent every 200 seconds
  ND router advertisements live for 1800 seconds
<output truncated>
```

This is an example of the output from the **show ipv6 protocols** privileged EXEC command:

```
Switch# show ipv6 protocols
IPv6 Routing Protocol is "connected"
IPv6 Routing Protocol is "static"
IPv6 Routing Protocol is "rip fer"
  Interfaces:
    Vlan6
    FastEthernet0/4
    FastEthernet0/11
    FastEthernet0/12
  Redistribution:
    None
```

This is an example of the output from the **show ipv6 static** privileged EXEC command:

```
Switch# show ipv6 static
IPv6 Static routes
Code: * - installed in RIB
* ::/0 via nexthop 3FFE:C000:0:7::777, distance 1
```

This is an example of the output from the **show ipv6 neighbor** privileged EXEC command:

```
Switch# show ipv6 neighbors
IPv6 Address                               Age Link-layer Addr State Interface
3FFE:C000:0:7::777                         - 0007.0007.0007 REACH V17
3FFE:C101:113:1::33                         - 0000.0000.0033 REACH Fa1/0/13
```

This is an example of the output from the **show ipv6 route** privileged EXEC command:

```
Switch# show ipv6 route
IPv6 Routing Table - Default - 1 entries
Codes: C - Connected, L - Local, S - Static, U - Per-user Static route
L   FF00::/8 [0/0]
    via Null0, receive
```

This is an example of the output from the **show ipv6 traffic** privileged EXEC command.

```
Switch# show ipv6 traffic
IPv6 statistics:
  Rcvd: 1 total, 1 local destination
        0 source-routed, 0 truncated
        0 format errors, 0 hop count exceeded
        0 bad header, 0 unknown option, 0 bad source
        0 unknown protocol, 0 not a router
        0 fragments, 0 total reassembled
        0 reassembly timeouts, 0 reassembly failures
  Sent: 36861 generated, 0 forwarded
        0 fragmented into 0 fragments, 0 failed
        0 encapsulation failed, 0 no route, 0 too big
        0 RPF drops, 0 RPF suppressed drops
  Mcast: 1 received, 36861 sent

ICMP statistics:
  Rcvd: 1 input, 0 checksum errors, 0 too short
        0 unknown info type, 0 unknown error type
  unreach: 0 routing, 0 admin, 0 neighbor, 0 address, 0 port
  parameter: 0 error, 0 header, 0 option
        0 hopcount expired, 0 reassembly timeout, 0 too big
        0 echo request, 0 echo reply
        0 group query, 0 group report, 0 group reduce
        1 router solicit, 0 router advert, 0 redirects
        0 neighbor solicit, 0 neighbor advert
  Sent: 10112 output, 0 rate-limited
        unreach: 0 routing, 0 admin, 0 neighbor, 0 address, 0 port
        parameter: 0 error, 0 header, 0 option
        0 hopcount expired, 0 reassembly timeout, 0 too big
        0 echo request, 0 echo reply
        0 group query, 0 group report, 0 group reduce
        0 router solicit, 9944 router advert, 0 redirects
        84 neighbor solicit, 84 neighbor advert

UDP statistics:
  Rcvd: 0 input, 0 checksum errors, 0 length errors
        0 no port, 0 dropped
  Sent: 26749 output

TCP statistics:
  Rcvd: 0 input, 0 checksum errors
  Sent: 0 output, 0 retransmitted
```



CHAPTER 30

Configuring IPv6 MLD Snooping

You can use Multicast Listener Discovery (MLD) snooping to enable efficient distribution of IP version 6 (IPv6) multicast data to clients and routers in a switched network on the Catalyst 2960 switch.



Note

To use IPv6, you must configure the dual IPv4 and IPv6 Switch Database Management (SDM) template on the switch. You select the template by entering the **sdm prefer dual-ipv4-and-ipv6 default** global configuration command.

For related information about SDM templates, see [Chapter 7, “Configuring SDM Templates.”](#)



Note

For complete syntax and usage information for the commands used in this chapter, see the command reference for this release or the Cisco IOS documentation referenced in the procedures.

This chapter includes these sections:

- [“Understanding MLD Snooping” section on page 30-1](#)
- [“Configuring IPv6 MLD Snooping” section on page 30-5](#)
- [“Displaying MLD Snooping Information” section on page 30-11](#)

Understanding MLD Snooping

In IP version 4 (IPv4), Layer 2 switches can use Internet Group Management Protocol (IGMP) snooping to limit the flooding of multicast traffic by dynamically configuring Layer 2 interfaces so that multicast traffic is forwarded to only those interfaces associated with IP multicast devices. In IPv6, MLD snooping performs a similar function. With MLD snooping, IPv6 multicast data is selectively forwarded to a list of ports that want to receive the data, instead of being flooded to all ports in a VLAN. This list is constructed by snooping IPv6 multicast control packets.

MLD is a protocol used by IPv6 multicast routers to discover the presence of multicast listeners (nodes wishing to receive IPv6 multicast packets) on its directly attached links and to discover which multicast packets are of interest to neighboring nodes. MLD is derived from IGMP; MLD version 1 (MLDv1) is equivalent to IGMPv2 and MLD version 2 (MLDv2) is equivalent to IGMPv3. MLD is a subprotocol of Internet Control Message Protocol version 6 (ICMPv6), and MLD messages are a subset of ICMPv6 messages, identified in IPv6 packets by a preceding Next Header value of 58.

The switch supports two versions of MLD snooping:

- MLDv1 snooping detects MLDv1 control packets and sets up traffic bridging based on IPv6 destination multicast addresses.
- MLDv2 basic snooping (MBSS) uses MLDv2 control packets to set up traffic forwarding based on IPv6 destination multicast addresses.

The switch can snoop on both MLDv1 and MLDv2 protocol packets and bridge IPv6 multicast data based on destination IPv6 multicast addresses.

Note

The switch does not support MLDv2 enhanced snooping (MESS), which sets up IPv6 source and destination multicast address-based forwarding.

MLD snooping can be enabled or disabled globally or per VLAN. When MLD snooping is enabled, a per-VLAN IPv6 multicast MAC address table is constructed in software and a per-VLAN IPv6 multicast address table is constructed in software and hardware. The switch then performs IPv6 multicast-address based bridging in hardware.

These sections describe some parameters of IPv6 MLD snooping:

- [MLD Messages, page 30-2](#)
- [MLD Queries, page 30-3](#)
- [Multicast Client Aging Robustness, page 30-3](#)
- [Multicast Router Discovery, page 30-3](#)
- [MLD Reports, page 30-4](#)
- [MLD Done Messages and Immediate-Leave, page 30-4](#)
- [Topology Change Notification Processing, page 30-5](#)

MLD Messages

MLDv1 supports three types of messages:

- Listener Queries are the equivalent of IGMPv2 queries and are either General Queries or Multicast-Address-Specific Queries (MASQs).
- Multicast Listener Reports are the equivalent of IGMPv2 reports.
- Multicast Listener Done messages are the equivalent of IGMPv2 leave messages.

MLDv2 supports MLDv2 queries and reports, as well as MLDv1 Report and Done messages.

Message timers and state transitions resulting from messages being sent or received are the same as those of IGMPv2 messages. MLD messages that do not have valid link-local IPv6 source addresses are ignored by MLD routers and switches.

MLD Queries

The switch sends out MLD queries, constructs an IPv6 multicast address database, and generates MLD group-specific and MLD group-and-source-specific queries in response to MLD Done messages. The switch also supports report suppression, report proxying, Immediate-Leave functionality, and static IPv6 multicast MAC-address configuration.

When MLD snooping is disabled, all MLD queries are flooded in the ingress VLAN.

When MLD snooping is enabled, received MLD queries are flooded in the ingress VLAN, and a copy of the query is sent to the CPU for processing. From the received query, MLD snooping builds the IPv6 multicast address database. It detects multicast router ports, maintains timers, sets report response time, learns the querier IP source address for the VLAN, learns the querier port in the VLAN, and maintains multicast-address aging.



Note

When the IPv6 multicast router is a Catalyst 6500 switch and you are using extended VLANs (in the range 1006 to 4094), IPv6 MLD snooping must be enabled on the extended VLAN on the Catalyst 6500 switch in order for the Catalyst 2960 switch to receive queries on the VLAN. For normal-range VLANs (1 to 1005), it is not necessary to enable IPv6 MLD snooping on the VLAN on the Catalyst 6500 switch.

When a group exists in the MLD snooping database, the switch responds to a group-specific query by sending an MLDv1 report. When the group is unknown, the group-specific query is flooded to the ingress VLAN.

When a host wants to leave a multicast group, it can send out an MLD Done message (equivalent to IGMP Leave message). When the switch receives an MLDv1 Done message, if Immediate-Leave is not enabled, the switch sends an MASQ to the port from which the message was received to determine if other devices connected to the port should remain in the multicast group.

Multicast Client Aging Robustness

You can configure port membership removal from addresses based on the number of queries. A port is removed from membership to an address only when there are no reports to the address on the port for the configured number of queries. The default number is 2.

Multicast Router Discovery

Like IGMP snooping, MLD snooping performs multicast router discovery, with these characteristics:

- Ports configured by a user never age out.
- Dynamic port learning results from MLDv1 snooping queries and IPv6 PIMv2 packets.
- If there are multiple routers on the same Layer 2 interface, MLD snooping tracks a single multicast router on the port (the router that most recently sent a router control packet).
- Dynamic multicast router port aging is based on a default timer of 5 minutes; the multicast router is deleted from the router port list if no control packet is received on the port for 5 minutes.
- IPv6 multicast router discovery only takes place when MLD snooping is enabled on the switch.

- Received IPv6 multicast router control packets are always flooded to the ingress VLAN, whether or not MLD snooping is enabled on the switch.
- After the discovery of the first IPv6 multicast router port, unknown IPv6 multicast data is forwarded only to the discovered router ports (before that time, all IPv6 multicast data is flooded to the ingress VLAN).

MLD Reports

The processing of MLDv1 join messages is essentially the same as with IGMPv2. When no IPv6 multicast routers are detected in a VLAN, reports are not processed or forwarded from the switch. When IPv6 multicast routers are detected and an MLDv1 report is received, an IPv6 multicast group address and an IPv6 multicast MAC address are entered in the VLAN MLD database. Then all IPv6 multicast traffic to the group within the VLAN is forwarded using this address. When MLD snooping is disabled, reports are flooded in the ingress VLAN.

When MLD snooping is enabled, MLD report suppression, called listener message suppression, is automatically enabled. With report suppression, the switch forwards the first MLDv1 report received by a group to IPv6 multicast routers; subsequent reports for the group are not sent to the routers. When MLD snooping is disabled, report suppression is disabled, and all MLDv1 reports are flooded to the ingress VLAN.

The switch also supports MLDv1 proxy reporting. When an MLDv1 MASQ is received, the switch responds with MLDv1 reports for the address on which the query arrived if the group exists in the switch on another port and if the port on which the query arrived is not the last member port for the address.

MLD Done Messages and Immediate-Leave

When the Immediate-Leave feature is enabled and a host sends an MLDv1 Done message (equivalent to an IGMP leave message), the port on which the Done message was received is immediately deleted from the group. You enable Immediate-Leave on VLANs and (as with IGMP snooping), you should only use the feature on VLANs where a single host is connected to the port. If the port was the last member of a group, the group is also deleted, and the leave information is forwarded to the detected IPv6 multicast routers.

When Immediate Leave is not enabled in a VLAN (which would be the case when there are multiple clients for a group on the same port) and a Done message is received on a port, an MASQ is generated on that port. The user can control when a port membership is removed for an existing address in terms of the number of MASQs. A port is removed from membership to an address when there are no MLDv1 reports to the address on the port for the configured number of queries.

The number of MASQs generated is configured by using the **ipv6 mld snooping last-listener-query count** global configuration command. The default number is 2.

The MASQ is sent to the IPv6 multicast address for which the Done message was sent. If there are no reports sent to the IPv6 multicast address specified in the MASQ during the switch maximum response time, the port on which the MASQ was sent is deleted from the IPv6 multicast address database. The maximum response time is the time configured by using the **ipv6 mld snooping last-listener-query-interval** global configuration command. If the deleted port is the last member of the multicast address, the multicast address is also deleted, and the switch sends the address leave information to all detected multicast routers.

Topology Change Notification Processing

When topology change notification (TCN) solicitation is enabled by using the **ipv6 mld snooping tcn query solicit** global configuration command, MLDv1 snooping sets the VLAN to flood all IPv6 multicast traffic with a configured number of MLDv1 queries before it begins sending multicast data only to selected ports. You set this value by using the **ipv6 mld snooping tcn flood query count** global configuration command. The default is to send two queries. The switch also generates MLDv1 global Done messages with valid link-local IPv6 source addresses when the switch becomes the STP root in the VLAN or when it is configured by the user. This is same as done in IGMP snooping.

Configuring IPv6 MLD Snooping

These sections describe how to configure IPv6 MLD snooping:

- [Default MLD Snooping Configuration, page 30-5](#)
- [MLD Snooping Configuration Guidelines, page 30-6](#)
- [Enabling or Disabling MLD Snooping, page 30-6](#)
- [Configuring a Static Multicast Group, page 30-8](#)
- [Configuring a Multicast Router Port, page 30-8](#)
- [Enabling MLD Immediate Leave, page 30-9](#)
- [Configuring MLD Snooping Queries, page 30-10](#)
- [Disabling MLD Listener Message Suppression, page 30-11](#)

Default MLD Snooping Configuration

Table 30-1 shows the default MLD snooping configuration.

Table 30-1 Default MLD Snooping Configuration

Feature	Default Setting
MLD snooping (Global)	Disabled.
MLD snooping (per VLAN)	Enabled. MLD snooping must be globally enabled for VLAN MLD snooping to take place.
IPv6 Multicast addresses	None configured.
IPv6 Multicast router ports	None configured.
MLD snooping Immediate Leave	Disabled.
MLD snooping robustness variable	Global: 2; Per VLAN: 0. Note The VLAN value overrides the global setting. When the VLAN value is 0, the VLAN uses the global count.
Last listener query count	Global: 2; Per VLAN: 0. Note The VLAN value overrides the global setting. When the VLAN value is 0, the VLAN uses the global count.

Table 30-1 Default MLD Snooping Configuration (continued)

Feature	Default Setting
Last listener query interval	Global: 1000 (1 second); VLAN: 0. Note The VLAN value overrides the global setting. When the VLAN value is 0, the VLAN uses the global interval.
TCN query solicit	Disabled.
TCN query count	2.
MLD listener suppression	Enabled.

MLD Snooping Configuration Guidelines

When configuring MLD snooping, consider these guidelines:

- You can configure MLD snooping characteristics at any time, but you must globally enable MLD snooping by using the **ipv6 mld snooping** global configuration command for the configuration to take effect.
- When the IPv6 multicast router is a Catalyst 6500 switch and you are using extended VLANs (in the range 1006 to 4094), IPv6 MLD snooping must be enabled on the extended VLAN on the Catalyst 6500 switch in order for the Catalyst 2960 switch to receive queries on the VLAN. For normal-range VLANs (1 to 1005), it is not necessary to enable IPv6 MLD snooping on the VLAN on the Catalyst 6500 switch.
- MLD snooping and IGMP snooping act independently of each other. You can enable both features at the same time on the switch.
- The maximum number of multicast entries allowed on the switch is determined by the configured SDM template.
- The maximum number of address entries allowed for the switch is 1000.

Enabling or Disabling MLD Snooping

By default, IPv6 MLD snooping is globally disabled on the switch and enabled on all VLANs. When MLD snooping is globally disabled, it is also disabled on all VLANs. When you globally enable MLD snooping, the VLAN configuration overrides the global configuration. That is, MLD snooping is enabled only on VLAN interfaces in the default state (enabled).

You can enable and disable MLD snooping on a per-VLAN basis or for a range of VLANs, but if you globally disable MLD snooping, it is disabled in all VLANs. If global snooping is enabled, you can enable or disable VLAN snooping.

Beginning in privileged EXEC mode, follow these steps to globally enable MLD snooping on the switch:

	Command	Purpose
Step 1	configure terminal	Enter global configuration mode.
Step 2	ipv6 mld snooping	Globally enable MLD snooping on the switch.
Step 3	end	Return to privileged EXEC mode.

	Command	Purpose
Step 4	copy running-config startup-config	(Optional) Save your entries in the configuration file.
Step 5	reload	Reload the operating system.

To globally disable MLD snooping on the switch, use the **no ipv6 mld snooping** global configuration command.

Beginning in privileged EXEC mode, follow these steps to enable MLD snooping on a VLAN.

**Note**

When the IPv6 multicast router is a Catalyst 6500 switch and you are using extended VLANs (in the range 1006 to 4094), IPv6 MLD snooping must be enabled on the extended VLAN on the Catalyst 6500 switch in order for the Catalyst 2960 switch to receive queries on the VLAN. For normal-range VLANs (1 to 1005), it is not necessary to enable IPv6 MLD snooping on the VLAN on the Catalyst 6500 switch.

	Command	Purpose
Step 1	configure terminal	Enter global configuration mode.
Step 2	ipv6 mld snooping	Globally enable MLD snooping on the switch.
Step 3	ipv6 mld snooping vlan <i>vlan-id</i>	Enable MLD snooping on the VLAN. The VLAN ID range is 1 to 1001 and 1006 to 4094. Note MLD snooping must be globally enabled for VLAN snooping to be enabled.
Step 4	end	Return to privileged EXEC mode.
Step 5	copy running-config startup-config	(Optional) Save your entries in the configuration file.

To disable MLD snooping on a VLAN interface, use the **no ipv6 mld snooping vlan *vlan-id*** global configuration command for the specified VLAN number.

Configuring a Static Multicast Group

Hosts or Layer 2 ports normally join multicast groups dynamically, but you can also statically configure an IPv6 multicast address and member ports for a VLAN.

Beginning in privileged EXEC mode, follow these steps to add a Layer 2 port as a member of a multicast group:

	Command	Purpose
Step 1	configure terminal	Enter global configuration mode
Step 2	ipv6 mld snooping vlan <i>vlan-id</i> static <i>ipv6_multicast_address</i> interface <i>interface-id</i>	Statically configure a multicast group with a Layer 2 port as a member of a multicast group: <ul style="list-style-type: none"> • <i>vlan-id</i> is the multicast group VLAN ID. The VLAN ID range is 1 to 1001 and 1006 to 4094. • <i>ipv6_multicast_address</i> is the 128-bit group IPv6 address. The address must be in the form specified in RFC 2373. • <i>interface-id</i> is the member port. It can be a physical interface or a port channel (1 to 48).
Step 3	end	Return to privileged EXEC mode.
Step 4	show ipv6 mld snooping multicast-address user or show ipv6 mld snooping multicast-address vlan <i>vlan-id</i> user	Verify the static member port and the IPv6 address.
Step 5	copy running-config startup-config	(Optional) Save your entries in the configuration file.

To remove a Layer 2 port from the multicast group, use the **no ipv6 mld snooping vlan** *vlan-id* **static** *mac-address* **interface** *interface-id* global configuration command. If all member ports are removed from a group, the group is deleted.

This example shows how to statically configure an IPv6 multicast group:

```
Switch# configure terminal
Switch(config)# ipv6 mld snooping vlan 2 static FF12::3 interface gigabitethernet0/1
Switch(config)# end
```

Configuring a Multicast Router Port

Although MLD snooping learns about router ports through MLD queries and PIMv6 queries, you can also use the command-line interface (CLI) to add a multicast router port to a VLAN. To add a multicast router port (add a static connection to a multicast router), use the **ipv6 mld snooping vlan mrouter** global configuration command on the switch.



Note

Static connections to multicast routers are supported only on switch ports.

Beginning in privileged EXEC mode, follow these steps to add a multicast router port to a VLAN:

	Command	Purpose
Step 1	configure terminal	Enter global configuration mode.
Step 2	ipv6 mld snooping vlan <i>vlan-id</i> mrouter interface <i>interface-id</i>	Specify the multicast router VLAN ID, and specify the interface to the multicast router. <ul style="list-style-type: none"> The VLAN ID range is 1 to 1001 and 1006 to 4094. The interface can be a physical interface or a port channel. The port-channel range is 1 to 48.
Step 3	end	Return to privileged EXEC mode.
Step 4	show ipv6 mld snooping mrouter [vlan <i>vlan-id</i>]	Verify that IPv6 MLD snooping is enabled on the VLAN interface.
Step 5	copy running-config startup-config	(Optional) Save your entries in the configuration file.

To remove a multicast router port from the VLAN, use the **no ipv6 mld snooping vlan *vlan-id* mrouter interface *interface-id*** global configuration command.

This example shows how to add a multicast router port to VLAN 200:

```
Switch# configure terminal
Switch(config)# ipv6 mld snooping vlan 200 mrouter interface gigabitethernet0/2
Switch(config)# exit
```

Enabling MLD Immediate Leave

When you enable MLDv1 Immediate Leave, the switch immediately removes a port from a multicast group when it detects an MLD Done message on that port. You should only use the Immediate-Leave feature when there is a single receiver present on every port in the VLAN. When there are multiple clients for a multicast group on the same port, you should not enable Immediate-Leave in a VLAN.

Beginning in privileged EXEC mode, follow these steps to enable MLDv1 Immediate Leave:

	Command	Purpose
Step 1	configure terminal	Enter global configuration mode.
Step 2	ipv6 mld snooping vlan <i>vlan-id</i> immediate-leave	Enable MLD Immediate Leave on the VLAN interface.
Step 3	end	Return to privileged EXEC mode.
Step 4	show ipv6 mld snooping vlan <i>vlan-id</i>	Verify that Immediate Leave is enabled on the VLAN interface.
Step 5	copy running-config startup-config	(Optional) Save your entries in the configuration file.

To disable MLD Immediate Leave on a VLAN, use the **no ipv6 mld snooping vlan *vlan-id* immediate-leave** global configuration command.

This example shows how to enable MLD Immediate Leave on VLAN 130:

```
Switch# configure terminal
Switch(config)# ipv6 mld snooping vlan 130 immediate-leave
Switch(config)# exit
```

Configuring MLD Snooping Queries

When Immediate Leave is not enabled and a port receives an MLD Done message, the switch generates MASQs on the port and sends them to the IPv6 multicast address for which the Done message was sent. You can optionally configure the number of MASQs that are sent and the length of time the switch waits for a response before deleting the port from the multicast group.

Beginning in privileged EXEC mode, follow these steps to configure MLD snooping query characteristics for the switch or for a VLAN:

	Command	Purpose
Step 1	configure terminal	Enter global configuration mode.
Step 2	ipv6 mld snooping robustness-variable <i>value</i>	(Optional) Set the number of queries that are sent before switch will deletes a listener (port) that does not respond to a general query. The range is 1 to 3; the default is 2.
Step 3	ipv6 mld snooping vlan <i>vlan-id</i> robustness-variable <i>value</i>	(Optional) Set the robustness variable on a VLAN basis, which determines the number of general queries that MLD snooping sends before aging out a multicast address when there is no MLD report response. The range is 1 to 3; the default is 0. When set to 0, the number used is the global robustness variable value.
Step 4	ipv6 mld snooping last-listener-query-count <i>count</i>	(Optional) Set the number of MASQs that the switch sends before aging out an MLD client. The range is 1 to 7; the default is 2. The queries are sent 1 second apart.
Step 5	ipv6 mld snooping vlan <i>vlan-id</i> last-listener-query-count <i>count</i>	(Optional) Set the last-listener query count on a VLAN basis. This value overrides the value configured globally. The range is 1 to 7; the default is 0. When set to 0, the global count value is used. Queries are sent 1 second apart.
Step 6	ipv6 mld snooping last-listener-query-interval <i>interval</i>	(Optional) Set the maximum response time that the switch waits after sending out a MASQ before deleting a port from the multicast group. The range is 100 to 32,768 thousands of a second. The default is 1000 (1 second).
Step 7	ipv6 mld snooping vlan <i>vlan-id</i> last-listener-query-interval <i>interval</i>	(Optional) Set the last-listener query interval on a VLAN basis. This value overrides the value configured globally. The range is 0 to 32,768 thousands of a second. The default is 0. When set to 0, the global last-listener query interval is used.
Step 8	ipv6 mld snooping tcn query solicit	(Optional) Enable topology change notification (TCN) solicitation, which means that VLANs flood all IPv6 multicast traffic for the configured number of queries before sending multicast data to only those ports requesting to receive it. The default is for TCN to be disabled.
Step 9	ipv6 mld snooping tcn flood query count <i>count</i>	(Optional) When TCN is enabled, specify the number of TCN queries to be sent. The range is from 1 to 10; the default is 2.
Step 10	end	Return to privileged EXEC mode.
Step 11	show ipv6 mld snooping querier [vlan <i>vlan-id</i>]	(Optional) Verify that the MLD snooping querier information for the switch or for the VLAN.
Step 12	copy running-config startup-config	(Optional) Save your entries in the configuration file.

This example shows how to set the MLD snooping global robustness variable to 3:

```
Switch# configure terminal
Switch(config)# ipv6 mld snooping robustness-variable 3
Switch(config)# exit
```

This example shows how to set the MLD snooping last-listener query count for a VLAN to 3:

```
Switch# configure terminal
Switch(config)# ipv6 mld snooping vlan 200 last-listener-query-count 3
Switch(config)# exit
```

This example shows how to set the MLD snooping last-listener query interval (maximum response time) to 2000 (2 seconds):

```
Switch# configure terminal
Switch(config)# ipv6 mld snooping last-listener-query-interval 2000
Switch(config)# exit
```

Disabling MLD Listener Message Suppression

MLD snooping listener message suppression is enabled by default. When it is enabled, the switch forwards only one MLD report per multicast router query. When message suppression is disabled, multiple MLD reports could be forwarded to the multicast routers.

Beginning in privileged EXEC mode, follow these steps to disable MLD listener message suppression:

	Command	Purpose
Step 1	configure terminal	Enter global configuration mode.
Step 2	no ipv6 mld snooping listener-message-suppression	Disable MLD message suppression.
Step 3	end	Return to privileged EXEC mode.
Step 4	show ipv6 mld snooping	Verify that IPv6 MLD snooping report suppression is disabled.
Step 5	copy running-config startup-config	(Optional) Save your entries in the configuration file.

To re-enable MLD message suppression, use the **ipv6 mld snooping listener-message-suppression** global configuration command.

Displaying MLD Snooping Information

You can display MLD snooping information for dynamically learned and statically configured router ports and VLAN interfaces. You can also display MAC address multicast entries for a VLAN configured for MLD snooping.

To display MLD snooping information, use one or more of the privileged EXEC commands in [Table 30-2](#).

Table 30-2 **Commands for Displaying MLD Snooping Information**

Command	Purpose
show ipv6 mld snooping [vlan <i>vlan-id</i>]	Display the MLD snooping configuration information for all VLANs on the switch or for a specified VLAN. (Optional) Enter vlan <i>vlan-id</i> to display information for a single VLAN. The VLAN ID range is 1 to 1001 and 1006 to 4094.
show ipv6 mld snooping mrouter [vlan <i>vlan-id</i>]	Display information on dynamically learned and manually configured multicast router interfaces. When you enable MLD snooping, the switch automatically learns the interface to which a multicast router is connected. These are dynamically learned interfaces. (Optional) Enter vlan <i>vlan-id</i> to display information for a single VLAN. The VLAN ID range is 1 to 1001 and 1006 to 4094.
show ipv6 mld snooping querier [vlan <i>vlan-id</i>]	Display information about the IPv6 address and incoming port for the most-recently received MLD query messages in the VLAN. (Optional) Enter vlan <i>vlan-id</i> to display information for a single VLAN. The VLAN ID range is 1 to 1001 and 1006 to 4094.
show ipv6 mld snooping multicast-address [vlan <i>vlan-id</i>] [count dynamic user]	Display all IPv6 multicast address information or specific IPv6 multicast address information for the switch or a VLAN. <ul style="list-style-type: none"> • Enter count to show the group count on the switch or in a VLAN. • Enter dynamic to display MLD snooping learned group information for the switch or for a VLAN. • Enter user to display MLD snooping user-configured group information for the switch or for a VLAN.
show ipv6 mld snooping multicast-address vlan <i>vlan-id</i> [<i>ipv6-multicast-address</i>]	Display MLD snooping for the specified VLAN and IPv6 multicast address.



CHAPTER 31

Configuring EtherChannels and Link-State Tracking

This chapter describes how to configure EtherChannels on Layer 2 ports on the Catalyst 2960 switch. EtherChannel provides fault-tolerant high-speed links between switches, routers, and servers. You can use it to increase the bandwidth between the wiring closets and the data center, and you can deploy it anywhere in the network where bottlenecks are likely to occur. EtherChannel provides automatic recovery for the loss of a link by redistributing the load across the remaining links. If a link fails, EtherChannel redirects traffic from the failed link to the remaining links in the channel without intervention. This chapter also describes how to configure link-state tracking.



Note

For complete syntax and usage information for the commands used in this chapter, see the command reference for this release.

This chapter consists of these sections:

- [Understanding EtherChannels, page 31-1](#)
- [Configuring EtherChannels, page 31-8](#)
- [Displaying EtherChannel, PAgP, and LACP Status, page 31-16](#)
- [Understanding Link-State Tracking, page 31-17](#)
- [Configuring Link-State Tracking, page 31-19](#)

Understanding EtherChannels

These sections describe how EtherChannels work:

- [EtherChannel Overview, page 31-2](#)
- [Port-Channel Interfaces, page 31-3](#)
- [Port Aggregation Protocol, page 31-4](#)
- [Link Aggregation Control Protocol, page 31-5](#)
- [EtherChannel On Mode, page 31-6](#)
- [Load Balancing and Forwarding Methods, page 31-6](#)

EtherChannel Overview

An EtherChannel consists of individual Fast Ethernet or Gigabit Ethernet links bundled into a single logical link as shown in [Figure 31-1](#).

Figure 31-1 Typical EtherChannel Configuration

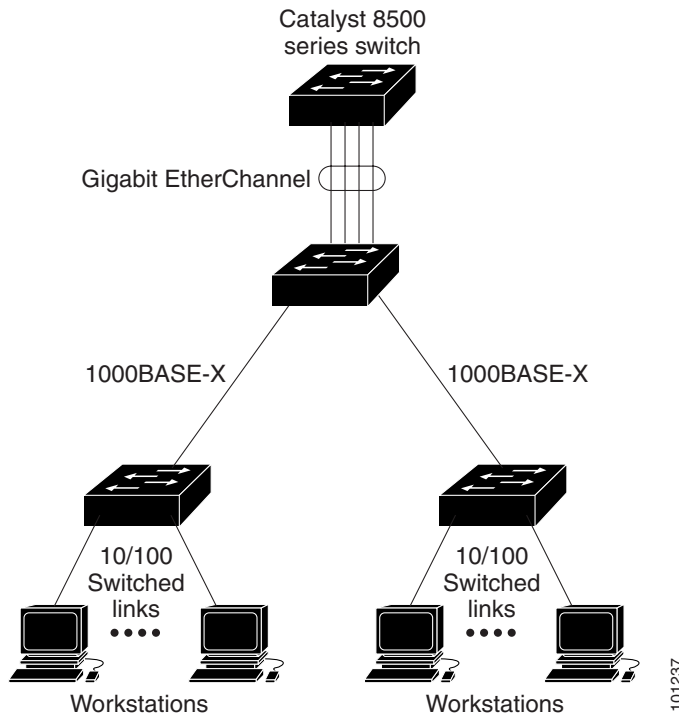

The EtherChannel provides full-duplex bandwidth up to 800 Mb/s (Fast EtherChannel) or 8 Gb/s (Gigabit EtherChannel) between your switch and another switch or host.

Each EtherChannel can consist of up to eight compatibly configured Ethernet ports. All ports in each EtherChannel must be configured as Layer 2 ports. The number of EtherChannels is limited to six. For more information, see the [“EtherChannel Configuration Guidelines”](#) section on page 31-9.

You can configure an EtherChannel in one of these modes: Port Aggregation Protocol (PAgP), Link Aggregation Control Protocol (LACP), or On. Configure both ends of the EtherChannel in the same mode:

- When you configure one end of an EtherChannel in either PAgP or LACP mode, the system negotiates with the other end of the channel to determine which ports should become active. Incompatible ports are suspended. Beginning with Cisco IOS Release 12.2(35)SE, instead of a suspended state, the local port is put into an independent state and continues to carry data traffic as would any other single link. The port configuration does not change, but the port does not participate in the EtherChannel.
- When you configure an EtherChannel in the **on** mode, no negotiations take place. The switch forces all compatible ports to become active in the EtherChannel. The other end of the channel (on the other switch) must also be configured in the **on** mode; otherwise, packet loss can occur.

If a link within an EtherChannel fails, traffic previously carried over that failed link moves to the remaining links within the EtherChannel. If traps are enabled on the switch, a trap is sent for a failure that identifies the switch, the EtherChannel, and the failed link. Inbound broadcast and multicast packets on one link in an EtherChannel are blocked from returning on any other link of the EtherChannel.

Port-Channel Interfaces

When you create a Layer 2 EtherChannel, a port-channel logical interface is involved. You can create the EtherChannel in these ways:

- Use the **channel-group** interface configuration command. This command automatically creates the port-channel logical interface when the channel group gets its first physical port. The **channel-group** command binds the physical (10/100/1000 ports) and the logical ports together as shown in Figure 31-2.
- Use the **interface port-channel** *port-channel-number* global configuration command to manually create the port-channel logical interface. Then use the **channel-group** *channel-group-number* interface configuration command to bind the logical interface to a physical port. The *channel-group-number* can be the same as the *port-channel-number*, or you can use a new number. If you use a new number, the **channel-group** command dynamically creates a new port channel.

Each EtherChannel has a port-channel logical interface numbered from 1 to 6. This port-channel interface number corresponds to the one specified with the **channel-group** interface configuration command.

Figure 31-2 Relationship of Physical Ports, Logical Port Channels, and Channel Groups

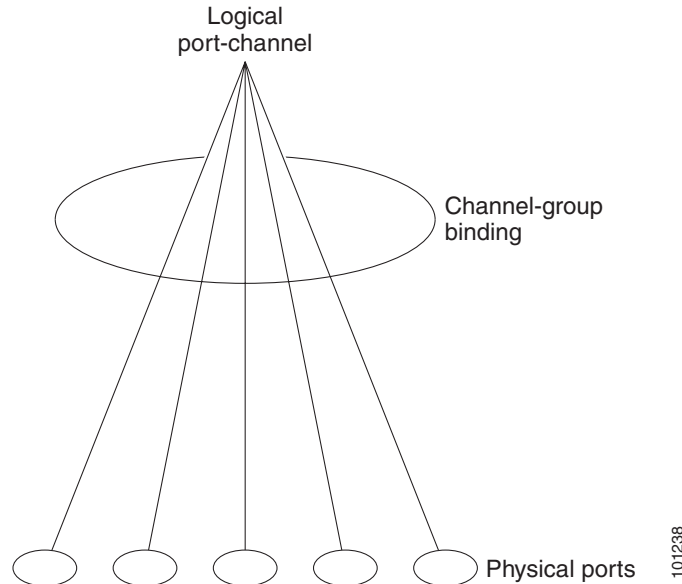

After you configure an EtherChannel, configuration changes applied to the port-channel interface apply to all the physical ports assigned to the port-channel interface. Configuration changes applied to the physical port affect only the port where you apply the configuration. To change the parameters of all ports in an EtherChannel, apply configuration commands to the port-channel interface, for example, spanning-tree commands or commands to configure a Layer 2 EtherChannel as a trunk.

Port Aggregation Protocol

The Port Aggregation Protocol (PAgP) is a Cisco-proprietary protocol that can be run only on Cisco switches and on those switches licensed by vendors to support PAgP. PAgP facilitates the automatic creation of EtherChannels by exchanging PAgP packets between Ethernet ports.

By using PAgP, the switch learns the identity of partners capable of supporting PAgP and the capabilities of each port. It then dynamically groups similarly configured ports into a single logical link (channel or aggregate port). Similarly configured ports are grouped based on hardware, administrative, and port parameter constraints. For example, PAgP groups the ports with the same speed, duplex mode, native VLAN, VLAN range, and trunking status and type. After grouping the links into an EtherChannel, PAgP adds the group to the spanning tree as a single switch port.

PAgP Modes

Table 31-1 shows the user-configurable EtherChannel PAgP modes for the **channel-group** interface configuration command.

Table 31-1 EtherChannel PAgP Modes

Mode	Description
auto	Places a port into a passive negotiating state, in which the port responds to PAgP packets it receives but does not start PAgP packet negotiation. This setting minimizes the transmission of PAgP packets.
desirable	Places a port into an active negotiating state, in which the port starts negotiations with other ports by sending PAgP packets.

Switch ports exchange PAgP packets only with partner ports configured in the **auto** or **desirable** modes. Ports configured in the **on** mode do not exchange PAgP packets.

Both the **auto** and **desirable** modes enable ports to negotiate with partner ports to form an EtherChannel based on criteria such as port speed and, for Layer 2 EtherChannels, trunking state and VLAN numbers.

Ports can form an EtherChannel when they are in different PAgP modes as long as the modes are compatible. For example:

- A port in the **desirable** mode can form an EtherChannel with another port that is in the **desirable** or **auto** mode.
- A port in the **auto** mode can form an EtherChannel with another port in the **desirable** mode.

A port in the **auto** mode cannot form an EtherChannel with another port that is also in the **auto** mode because neither port starts PAgP negotiation.

If your switch is connected to a partner that is PAgP-capable, you can configure the switch port for nonsilent operation by using the **non-silent** keyword. If you do not specify **non-silent** with the **auto** or **desirable** mode, silent mode is assumed.

Use the silent mode when the switch is connected to a device that is not PAgP-capable and seldom, if ever, sends packets. An example of a silent partner is a file server or a packet analyzer that is not generating traffic. In this case, running PAgP on a physical port connected to a silent partner prevents that switch port from ever becoming operational. However, the silent setting allows PAgP to operate, to attach the port to a channel group, and to use the port for transmission.

PAgP Interaction with Other Features

The Dynamic Trunking Protocol (DTP) and the Cisco Discovery Protocol (CDP) send and receive packets over the physical ports in the EtherChannel. Trunk ports send and receive PAgP protocol data units (PDUs) on the lowest numbered VLAN.

In Layer 2 EtherChannels, the first port in the channel that comes up provides its MAC address to the EtherChannel. If this port is removed from the bundle, one of the remaining ports in the bundle provides its MAC address to the EtherChannel.

PAgP sends and receives PAgP PDUs only from ports that are up and have PAgP enabled for the auto or desirable mode.

Link Aggregation Control Protocol

The LACP is defined in IEEE 802.3ad and enables Cisco switches to manage Ethernet channels between switches that conform to the IEEE 802.3ad protocol. LACP facilitates the automatic creation of EtherChannels by exchanging LACP packets between Ethernet ports.

By using LACP, the switch learns the identity of partners capable of supporting LACP and the capabilities of each port. It then dynamically groups similarly configured ports into a single logical link (channel or aggregate port). Similarly configured ports are grouped based on hardware, administrative, and port parameter constraints. For example, LACP groups the ports with the same speed, duplex mode, native VLAN, VLAN range, and trunking status and type. After grouping the links into an EtherChannel, LACP adds the group to the spanning tree as a single switch port.

LACP Modes

Table 31-2 shows the user-configurable EtherChannel LACP modes for the **channel-group** interface configuration command.

Table 31-2 EtherChannel LACP Modes

Mode	Description
active	Places a port into an active negotiating state in which the port starts negotiations with other ports by sending LACP packets.
passive	Places a port into a passive negotiating state in which the port responds to LACP packets that it receives, but does not start LACP packet negotiation. This setting minimizes the transmission of LACP packets.

Both the **active** and **passive LACP** modes enable ports to negotiate with partner ports to an EtherChannel based on criteria such as port speed and, for Layer 2 EtherChannels, trunking state and VLAN numbers.

Ports can form an EtherChannel when they are in different LACP modes as long as the modes are compatible. For example:

- A port in the **active** mode can form an EtherChannel with another port that is in the **active** or **passive** mode.
- A port in the **passive** mode cannot form an EtherChannel with another port that is also in the **passive** mode because neither port starts LACP negotiation.

LACP Interaction with Other Features

The DTP and the CDP send and receive packets over the physical ports in the EtherChannel. Trunk ports send and receive LACP PDUs on the lowest numbered VLAN.

In Layer 2 EtherChannels, the first port in the channel that comes up provides its MAC address to the EtherChannel. If this port is removed from the bundle, one of the remaining ports in the bundle provides its MAC address to the EtherChannel.

LACP sends and receives LACP PDUs only from ports that are up and have LACP enabled for the active or passive mode.

EtherChannel On Mode

EtherChannel **on** mode can be used to manually configure an EtherChannel. The **on** mode forces a port to join an EtherChannel without negotiations. The **on** mode can be useful if the remote device does not support PAgP or LACP. In the **on** mode, a usable EtherChannel exists only when the switches at both ends of the link are configured in the **on** mode.

Ports that are configured in the **on** mode in the same channel group must have compatible port characteristics, such as speed and duplex. Ports that are not compatible are suspended, even though they are configured in the **on** mode.



Caution

You should use care when using the **on** mode. This is a manual configuration, and ports on both ends of the EtherChannel must have the same configuration. If the group is misconfigured, packet loss or spanning-tree loops can occur.

Load Balancing and Forwarding Methods

EtherChannel balances the traffic load across the links in a channel by reducing part of the binary pattern formed from the addresses in the frame to a numerical value that selects one of the links in the channel. EtherChannel load balancing can use MAC addresses or IP addresses, source or destination addresses, or both source and destination addresses. The selected mode applies to all EtherChannels configured on the switch. You configure the load balancing and forwarding method by using the **port-channel load-balance** global configuration command.

With source-MAC address forwarding, when packets are forwarded to an EtherChannel, they are distributed across the ports in the channel based on the source-MAC address of the incoming packet. Therefore, to provide load balancing, packets from different hosts use different ports in the channel, but packets from the same host use the same port in the channel.

With destination-MAC address forwarding, when packets are forwarded to an EtherChannel, they are distributed across the ports in the channel based on the destination host's MAC address of the incoming packet. Therefore, packets to the same destination are forwarded over the same port, and packets to a different destination are sent on a different port in the channel.

With source-and-destination MAC address forwarding, when packets are forwarded to an EtherChannel, they are distributed across the ports in the channel based on both the source and destination MAC addresses. This forwarding method, a combination source-MAC and destination-MAC address forwarding methods of load distribution, can be used if it is not clear whether source-MAC or destination-MAC address forwarding is better suited on a particular switch. With source-and-destination MAC-address forwarding, packets sent from host A to host B, host A to host C, and host C to host B could all use different ports in the channel.

With source-IP address-based forwarding, when packets are forwarded to an EtherChannel, they are distributed across the ports in the EtherChannel based on the source-IP address of the incoming packet. Therefore, to provide load-balancing, packets from different IP addresses use different ports in the channel, but packets from the same IP address use the same port in the channel.

With destination-IP address-based forwarding, when packets are forwarded to an EtherChannel, they are distributed across the ports in the EtherChannel based on the destination-IP address of the incoming packet. Therefore, to provide load-balancing, packets from the same IP source address sent to different IP destination addresses could be sent on different ports in the channel. But packets sent from different source IP addresses to the same destination IP address are always sent on the same port in the channel.

With source-and-destination IP address-based forwarding, packets are sent to an EtherChannel and distributed across the EtherChannel ports, based on both the source and destination IP addresses of the incoming packet. This forwarding method, a combination of source-IP and destination-IP address-based forwarding, can be used if it is not clear whether source-IP or destination-IP address-based forwarding is better suited on a particular switch. In this method, packets sent from the IP address A to IP address B, from IP address A to IP address C, and from IP address C to IP address B could all use different ports in the channel.

Different load-balancing methods have different advantages, and the choice of a particular load-balancing method should be based on the position of the switch in the network and the kind of traffic that needs to be load-distributed. In [Figure 31-3](#), an EtherChannel from a switch that is aggregating data from four workstations communicates with a router. Because the router is a single-MAC-address device, source-based forwarding on the switch EtherChannel ensures that the switch uses all available bandwidth to the router. The router is configured for destination-based forwarding because the large number of workstations ensures that the traffic is evenly distributed from the router EtherChannel.

Use the option that provides the greatest variety in your configuration. For example, if the traffic on a channel is only going to a single MAC address, using the destination-MAC address always chooses the same link in the channel. Using source addresses or IP addresses might result in better load balancing.

Figure 31-3 Load Distribution and Forwarding Methods

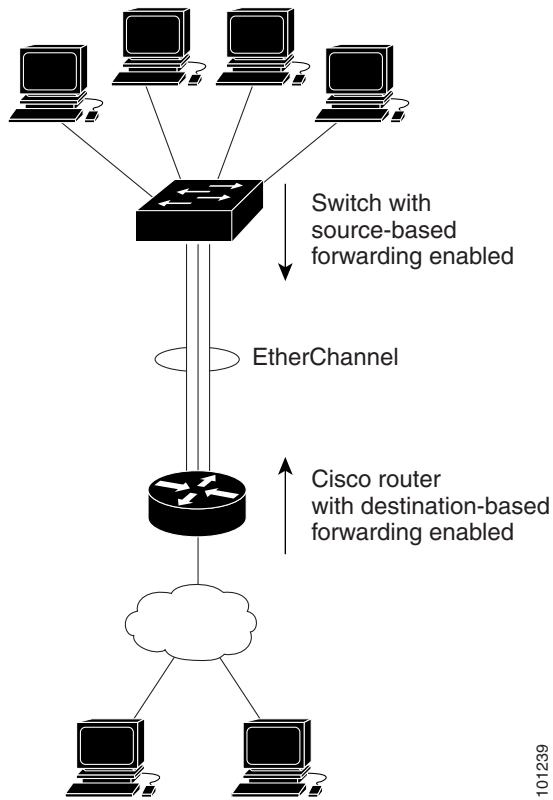

101239

Configuring EtherChannels

These sections contain this configuration information:

- [Default EtherChannel Configuration](#), page 31-9
- [EtherChannel Configuration Guidelines](#), page 31-9
- [Configuring Layer 2 EtherChannels](#), page 31-10 (required)
- [Configuring EtherChannel Load Balancing](#), page 31-12 (optional)
- [Configuring the PAgP Learn Method and Priority](#), page 31-13 (optional)
- [Configuring LACP Hot-Standby Ports](#), page 31-14 (optional)



Note

Make sure that the ports are correctly configured. For more information, see the [“EtherChannel Configuration Guidelines”](#) section on page 31-9.



Note

After you configure an EtherChannel, configuration changes applied to the port-channel interface apply to all the physical ports assigned to the port-channel interface, and configuration changes applied to the physical port affect only the port where you apply the configuration.

Default EtherChannel Configuration

Table 31-3 shows the default EtherChannel configuration.

Table 31-3 *Default EtherChannel Configuration*

Feature	Default Setting
Channel groups	None assigned.
Port-channel logical interface	None defined.
PAgP mode	No default.
PAgP learn method	Aggregate-port learning on all ports.
PAgP priority	128 on all ports.
LACP mode	No default.
LACP learn method	Aggregate-port learning on all ports.
LACP port priority	32768 on all ports.
LACP system priority	32768.
LACP system ID	LACP system priority and the switch MAC address.
Load balancing	Load distribution on the switch is based on the source-MAC address of the incoming packet.

EtherChannel Configuration Guidelines

If improperly configured, some EtherChannel ports are automatically disabled to avoid network loops and other problems. Follow these guidelines to avoid configuration problems:

- Do not try to configure more than 6 EtherChannels on the switch.
- Configure a PAgP EtherChannel with up to eight Ethernet ports of the same type.
- Configure a LACP EtherChannel with up to 16 Ethernet ports of the same type. Up to eight ports can be active, and up to eight ports can be in standby mode.
- Configure all ports in an EtherChannel to operate at the same speeds and duplex modes.
- Enable all ports in an EtherChannel. A port in an EtherChannel that is disabled by using the **shutdown** interface configuration command is treated as a link failure, and its traffic is transferred to one of the remaining ports in the EtherChannel.
- When a group is first created, all ports follow the parameters set for the first port to be added to the group. If you change the configuration of one of these parameters, you must also make the changes to all ports in the group:
 - Allowed-VLAN list
 - Spanning-tree path cost for each VLAN
 - Spanning-tree port priority for each VLAN
 - Spanning-tree Port Fast setting
- Do not configure a port to be a member of more than one EtherChannel group.

- Do not configure an EtherChannel in both the PAgP and LACP modes. EtherChannel groups running PAgP and LACP can coexist on the same switch. Individual EtherChannel groups can run either PAgP or LACP, but they cannot interoperate.
- Do not configure a Switched Port Analyzer (SPAN) destination port as part of an EtherChannel.
- Do not configure a secure port as part of an EtherChannel or the reverse.
- Do not configure a port that is an active or a not-yet-active member of an EtherChannel as an IEEE 802.1x port. If you try to enable IEEE 802.1x on an EtherChannel port, an error message appears, and IEEE 802.1x is not enabled.
- If EtherChannels are configured on switch interfaces, remove the EtherChannel configuration from the interfaces before globally enabling IEEE 802.1x on a switch by using the **dot1x system-auth-control** global configuration command.
- For Layer 2 EtherChannels:
 - Assign all ports in the EtherChannel to the same VLAN, or configure them as trunks. Ports with different native VLANs cannot form an EtherChannel.
 - If you configure an EtherChannel from trunk ports, verify that the trunking mode (ISL or IEEE 802.1Q) is the same on all the trunks. Inconsistent trunk modes on EtherChannel ports can have unexpected results.
 - An EtherChannel supports the same allowed range of VLANs on all the ports in a trunking Layer 2 EtherChannel. If the allowed range of VLANs is not the same, the ports do not form an EtherChannel even when PAgP is set to the **auto** or **desirable** mode.
 - Ports with different spanning-tree path costs can form an EtherChannel if they are otherwise compatibly configured. Setting different spanning-tree path costs does not, by itself, make ports incompatible for the formation of an EtherChannel.

Configuring Layer 2 EtherChannels

You configure Layer 2 EtherChannels by assigning ports to a channel group with the **channel-group** interface configuration command. This command automatically creates the port-channel logical interface.

Beginning in privileged EXEC mode, follow these steps to assign a Layer 2 Ethernet port to a Layer 2 EtherChannel. This procedure is required.

	Command	Purpose
Step 1	configure terminal	Enter global configuration mode.
Step 2	interface <i>interface-id</i>	Specify a physical port, and enter interface configuration mode. Valid interfaces include physical ports. For a PAgP EtherChannel, you can configure up to eight ports of the same type and speed for the same group. For a LACP EtherChannel, you can configure up to 16 Ethernet ports of the same type. Up to eight ports can be active, and up to eight ports can be in standby mode.

	Command	Purpose
Step 3	switchport mode {access trunk} switchport access vlan <i>vlan-id</i>	Assign all ports as static-access ports in the same VLAN, or configure them as trunks. If you configure the port as a static-access port, assign it to only one VLAN. The range is 1 to 4094.
Step 4	channel-group <i>channel-group-number</i> mode { auto [non-silent] desirable [non-silent] on } { active passive }	Assign the port to a channel group, and specify the PAgP or the LACP mode. For <i>channel-group-number</i> , the range is 1 to 6. For mode , select one of these keywords: <ul style="list-style-type: none"> • auto—Enables PAgP only if a PAgP device is detected. It places the port into a passive negotiating state, in which the port responds to PAgP packets it receives but does not start PAgP packet negotiation. • desirable—Unconditionally enables PAgP. It places the port into an active negotiating state, in which the port starts negotiations with other ports by sending PAgP packets. • on—Forces the port to channel without PAgP or LACP. In the on mode, an EtherChannel exists only when a port group in the on mode is connected to another port group in the on mode. • non-silent—(Optional) If your switch is connected to a partner that is PAgP-capable, configure the switch port for nonsilent operation when the port is in the auto or desirable mode. If you do not specify non-silent, silent is assumed. The silent setting is for connections to file servers or packet analyzers. This setting allows PAgP to operate, to attach the port to a channel group, and to use the port for transmission. • active—Enables LACP only if a LACP device is detected. It places the port into an active negotiating state in which the port starts negotiations with other ports by sending LACP packets. • passive—Enables LACP on the port and places it into a passive negotiating state in which the port responds to LACP packets that it receives, but does not start LACP packet negotiation. For information on compatible modes for the switch and its partner, see the “PAgP Modes” section on page 31-4 and the “LACP Modes” section on page 31-5.
Step 5	end	Return to privileged EXEC mode.
Step 6	show running-config	Verify your entries.
Step 7	copy running-config startup-config	(Optional) Save your entries in the configuration file.

To remove a port from the EtherChannel group, use the **no channel-group** interface configuration command.

This example shows how to configure an EtherChannel. It assigns two ports as static-access ports in VLAN 10 to channel 5 with the PAgP mode **desirable**:

```
Switch# configure terminal
Switch(config)# interface range gigabitethernet0/1 -2
Switch(config-if-range)# switchport mode access
Switch(config-if-range)# switchport access vlan 10
Switch(config-if-range)# channel-group 5 mode desirable non-silent
Switch(config-if-range)# end
```

This example shows how to configure an EtherChannel. It assigns two ports as static-access ports in VLAN 10 to channel 5 with the LACP mode **active**:

```
Switch# configure terminal
Switch(config)# interface range gigabitethernet0/1 -2
Switch(config-if-range)# switchport mode access
Switch(config-if-range)# switchport access vlan 10
Switch(config-if-range)# channel-group 5 mode active
Switch(config-if-range)# end
```

Configuring EtherChannel Load Balancing

This section describes how to configure EtherChannel load balancing by using source-based or destination-based forwarding methods. For more information, see the [“Load Balancing and Forwarding Methods” section on page 31-6](#).

Beginning in privileged EXEC mode, follow these steps to configure EtherChannel load balancing. This procedure is optional.

	Command	Purpose
Step 1	configure terminal	Enter global configuration mode.
Step 2	port-channel load-balance {dst-ip dst-mac src-dst-ip src-dst-mac src-ip src-mac}	Configure an EtherChannel load-balancing method. The default is src-mac . Select one of these load-distribution methods: <ul style="list-style-type: none"> • dst-ip—Load distribution is based on the destination-host IP address. • dst-mac—Load distribution is based on the destination-host MAC address of the incoming packet. • src-dst-ip—Load distribution is based on the source-and-destination host-IP address. • src-dst-mac—Load distribution is based on the source-and-destination host-MAC address. • src-ip—Load distribution is based on the source-host IP address. • src-mac—Load distribution is based on the source-MAC address of the incoming packet.
Step 3	end	Return to privileged EXEC mode.
Step 4	show etherchannel load-balance	Verify your entries.
Step 5	copy running-config startup-config	(Optional) Save your entries in the configuration file.

To return EtherChannel load balancing to the default configuration, use the **no port-channel load-balance** global configuration command.

Configuring the PAgP Learn Method and Priority

Network devices are classified as PAgP physical learners or aggregate-port learners. A device is a physical learner if it learns addresses by physical ports and directs transmissions based on that knowledge. A device is an aggregate-port learner if it learns addresses by aggregate (logical) ports. The learn method must be configured the same at both ends of the link.

When a device and its partner are both aggregate-port learners, they learn the address on the logical port-channel. The device sends packets to the source by using any of the ports in the EtherChannel. With aggregate-port learning, it is not important on which physical port the packet arrives.

PAgP cannot automatically detect when the partner device is a physical learner and when the local device is an aggregate-port learner. Therefore, you must manually set the learning method on the local device to learn addresses by physical ports. You also must set the load-distribution method to source-based distribution, so that any given source MAC address is always sent on the same physical port.

You also can configure a single port within the group for all transmissions and use other ports for hot standby. The unused ports in the group can be swapped into operation in just a few seconds if the selected single port loses hardware-signal detection. You can configure which port is always selected for packet transmission by changing its priority with the **pagp port-priority** interface configuration command. The higher the priority, the more likely that the port will be selected.



Note

The switch supports address learning only on aggregate ports even though the **physical-port** keyword is provided in the CLI. The **pagp learn-method** command and the **pagp port-priority** command have no effect on the switch hardware, but they are required for PAgP interoperability with devices that only support address learning by physical ports.

When the link partner of the Catalyst 2960 switch is a physical learner (such as a Catalyst 1900 series switch), we recommend that you configure the Catalyst 2960 switch as a physical-port learner by using the **pagp learn-method physical-port** interface configuration command. Set the load-distribution method based on the source MAC address by using the **port-channel load-balance src-mac** global configuration command. The switch then sends packets to the Catalyst 1900 switch using the same port in the EtherChannel from which it learned the source address. Only use the **pagp learn-method** command in this situation.

Beginning in privileged EXEC mode, follow these steps to configure your switch as a PAgP physical-port learner and to adjust the priority so that the same port in the bundle is selected for sending packets. This procedure is optional.

	Command	Purpose
Step 1	configure terminal	Enter global configuration mode.
Step 2	interface <i>interface-id</i>	Specify the port for transmission, and enter interface configuration mode.

	Command	Purpose
Step 3	pagp learn-method physical-port	Select the PAgP learning method. By default, aggregation-port learning is selected, which means the switch sends packets to the source by using any of the ports in the EtherChannel. With aggregate-port learning, it is not important on which physical port the packet arrives. Select physical-port to connect with another switch that is a physical learner. Make sure to configure the port-channel load-balance global configuration command to src-mac as described in the “ Configuring EtherChannel Load Balancing ” section on page 31-12. The learning method must be configured the same at both ends of the link.
Step 4	pagp port-priority <i>priority</i>	Assign a priority so that the selected port is chosen for packet transmission. For <i>priority</i> , the range is 0 to 255. The default is 128. The higher the priority, the more likely that the port will be used for PAgP transmission.
Step 5	end	Return to privileged EXEC mode.
Step 6	show running-config or show pagp channel-group-number internal	Verify your entries.
Step 7	copy running-config startup-config	(Optional) Save your entries in the configuration file.

To return the priority to its default setting, use the **no pagp port-priority** interface configuration command. To return the learning method to its default setting, use the **no pagp learn-method** interface configuration command.

Configuring LACP Hot-Standby Ports

When enabled, LACP tries to configure the maximum number of LACP-compatible ports in a channel, up to a maximum of 16 ports. Only eight LACP links can be active at one time. The software places any additional links in a hot-standby mode. If one of the active links becomes inactive, a link that is in the hot-standby mode becomes active in its place.

If you configure more than eight links for an EtherChannel group, the software automatically decides which of the hot-standby ports to make active based on the LACP priority. To every link between systems that operate LACP, the software assigns a unique priority made up of these elements (in priority order):

- LACP system priority
- System ID (the switch MAC address)
- LACP port priority
- Port number

In priority comparisons, numerically lower values have higher priority. The priority decides which ports should be put in standby mode when there is a hardware limitation that prevents all compatible ports from aggregating.

Determining which ports are active and which are hot standby is a two-step procedure. First the system with a numerically lower system priority and system-id is placed in charge of the decision. Next, that system decides which ports are active and which are hot standby, based on its values for port priority and port number. The port-priority and port-number values for the other system are not used.

You can change the default values of the LACP system priority and the LACP port priority to affect how the software selects active and standby links. For more information, see the “[Configuring the LACP System Priority](#)” section on page 31-15 and the “[Configuring the LACP Port Priority](#)” section on page 31-15.

Configuring the LACP System Priority

You can configure the system priority for all the EtherChannels that are enabled for LACP by using the **lacp system-priority** global configuration command. You cannot configure a system priority for each LACP-configured channel. By changing this value from the default, you can affect how the software selects active and standby links.

You can use the **show etherchannel summary** privileged EXEC command to see which ports are in the hot-standby mode (denoted with an H port-state flag).

Beginning in privileged EXEC mode, follow these steps to configure the LACP system priority. This procedure is optional.

	Command	Purpose
Step 1	configure terminal	Enter global configuration mode.
Step 2	lacp system-priority <i>priority</i>	Configure the LACP system priority. For <i>priority</i> , the range is 1 to 65535. The default is 32768. The lower the value, the higher the system priority.
Step 3	end	Return to privileged EXEC mode.
Step 4	show running-config or show lacp sys-id	Verify your entries.
Step 5	copy running-config startup-config	(Optional) Save your entries in the configuration file.

To return the LACP system priority to the default value, use the **no lacp system-priority** global configuration command.

Configuring the LACP Port Priority

By default, all ports use the same port priority. If the local system has a lower value for the system priority and the system ID than the remote system, you can affect which of the hot-standby links become active first by changing the port priority of LACP EtherChannel ports to a lower value than the default. The hot-standby ports that have lower port numbers become active in the channel first. You can use the **show etherchannel summary** privileged EXEC command to see which ports are in the hot-standby mode (denoted with an H port-state flag).

**Note**

If LACP is not able to aggregate all the ports that are compatible (for example, the remote system might have more restrictive hardware limitations), all the ports that cannot be actively included in the EtherChannel are put in the hot-standby state and are used only if one of the channeled ports fails.

Beginning in privileged EXEC mode, follow these steps to configure the LACP port priority. This procedure is optional.

	Command	Purpose
Step 1	configure terminal	Enter global configuration mode.
Step 2	interface <i>interface-id</i>	Specify the port to be configured, and enter interface configuration mode.
Step 3	lACP port-priority <i>priority</i>	Configure the LACP port priority. For <i>priority</i> , the range is 1 to 65535. The default is 32768. The lower the value, the more likely that the port will be used for LACP transmission.
Step 4	end	Return to privileged EXEC mode.
Step 5	show running-config or show lACP [<i>channel-group-number</i>] internal	Verify your entries.
Step 6	copy running-config startup-config	(Optional) Save your entries in the configuration file.

To return the LACP port priority to the default value, use the **no lACP port-priority** interface configuration command.

Displaying EtherChannel, PAgP, and LACP Status

To display EtherChannel, PAgP, and LACP status information, use the privileged EXEC commands described in [Table 31-4](#):

Table 31-4 Commands for Displaying EtherChannel, PAgP, and LACP Status

Command	Description
show etherchannel [<i>channel-group-number</i> { detail port port-channel protocol summary }] { detail load-balance port port-channel protocol summary }	Displays EtherChannel information in a brief, detailed, and one-line summary form. Also displays the load-balance or frame-distribution scheme, port, port-channel, and protocol information.
show pagp [<i>channel-group-number</i>] { counters internal neighbor }	Displays PAgP information such as traffic information, the internal PAgP configuration, and neighbor information.
show lACP [<i>channel-group-number</i>] { counters internal neighbor }	Displays LACP information such as traffic information, the internal LACP configuration, and neighbor information.

You can clear PAgP channel-group information and traffic counters by using the **clear pagp** [*channel-group-number* **counters** | **counters**] privileged EXEC command.

You can clear LACP channel-group information and traffic counters by using the **clear lacp** {*channel-group-number* **counters** | **counters**} privileged EXEC command.

For detailed information about the fields in the displays, see the command reference for this release.

Understanding Link-State Tracking

Link-state tracking, also known as trunk failover, is a feature that binds the link state of multiple interfaces. For example, link-state tracking provides redundancy in the network when used with server NIC adapter teaming. When the server network adapters are configured in a primary or secondary relationship known as teaming, if the link is lost on the primary interface, connectivity is transparently changed to the secondary interface.

[Figure 31-4 on page 31-19](#) shows a network configured with link-state tracking. To enable link-state tracking, create a *link-state group*, and specify the interfaces that are assigned to the link-state group. An interface can be an aggregation of ports (an EtherChannel) or a single physical port in access or trunk mode. In a link-state group, these interfaces are bundled together. The *downstream interfaces* are bound to the *upstream interfaces*. Interfaces connected to servers are referred to as downstream interfaces, and interfaces connected to distribution switches and network devices are referred to as upstream interfaces.

The configuration in [Figure 31-4](#) ensures that the network traffic flow is balanced as follows:

- For links to switches and other network devices
 - Server 1 and server 2 use switch A for primary links and switch B for secondary links.
 - Server 3 and server 4 use switch B for primary links and switch A for secondary links.
- Link-state group 1 on switch A
 - Switch A provides primary links to server 1 and server 2 through link-state group 1. Port 1 is connected to server 1, and port 2 is connected to server 2. Port 1 and port 2 are the downstream interfaces in link-state group 1.
 - Port 5 and port 6 are connected to distribution switch 1 through link-state group 1. Port 5 and port 6 are the upstream interfaces in link-state group 1.
- Link-state group 2 on switch A
 - Switch A provides secondary links to server 3 and server 4 through link-state group 2. Port 3 is connected to server 3, and port 4 is connected to server 4. Port 3 and port 4 are the downstream interfaces in link-state group 2.
 - Port 7 and port 8 are connected to distribution switch 2 through link-state group 2. Port 7 and port 8 are the upstream interfaces in link-state group 2.
- Link-state group 2 on switch B
 - Switch B provides primary links to server 3 and server 4 through link-state group 2. Port 3 is connected to server 3, and port 4 is connected to server 4. Port 3 and port 4 are the downstream interfaces in link-state group 2.
 - Port 5 and port 6 are connected to distribution switch 2 through link-state group 2. Port 5 and port 6 are the upstream interfaces in link-state group 2.

- Link-state group 1 on switch B
 - Switch B provides secondary links to server 1 and server 2 through link-state group 1. Port 1 is connected to server 1, and port 2 is connected to server 2. Port 1 and port 2 are the downstream interfaces in link-state group 1.
 - Port 7 and port 8 are connected to distribution switch 1 through link-state group 1. Port 7 and port 8 are the upstream interfaces in link-state group 1.

In a link-state group, the upstream ports can become unavailable or lose connectivity because the distribution switch or router fails, the cables are disconnected, or the link is lost. These are the interactions between the downstream and upstream interfaces when link-state tracking is enabled:

- If any of the upstream interfaces are in the link-up state, the downstream interfaces can change to or remain in the link-up state.
- If all of the upstream interfaces become unavailable, link-state tracking automatically puts the downstream interfaces in the error-disabled state. Connectivity to and from the servers is automatically changed from the primary server interface to the secondary server interface.

As an example of a connectivity change from link-state group 1 to link-state group 2 on switch A, see [Figure 31-4 on page 31-19](#). If the upstream link for port 6 is lost, the link states of downstream ports 1 and 2 do not change. However, if the link for upstream port 5 is also lost, the link state of the downstream ports changes to the link-down state. Connectivity to server 1 and server 2 is then changed from link-state group 1 to link-state group 2. The downstream ports 3 and 4 do not change state because they are in link-group 2.

- If the link-state group is configured, link-state tracking is disabled, and the upstream interfaces lose connectivity, the link states of the downstream interfaces remain unchanged. The server does not recognize that upstream connectivity has been lost and does not failover to the secondary interface.

You can recover a downstream interface link-down condition by removing the failed downstream port from the link-state group. To recover multiple downstream interfaces, disable the link-state group.

Figure 31-4 Typical Link-State Tracking Configuration

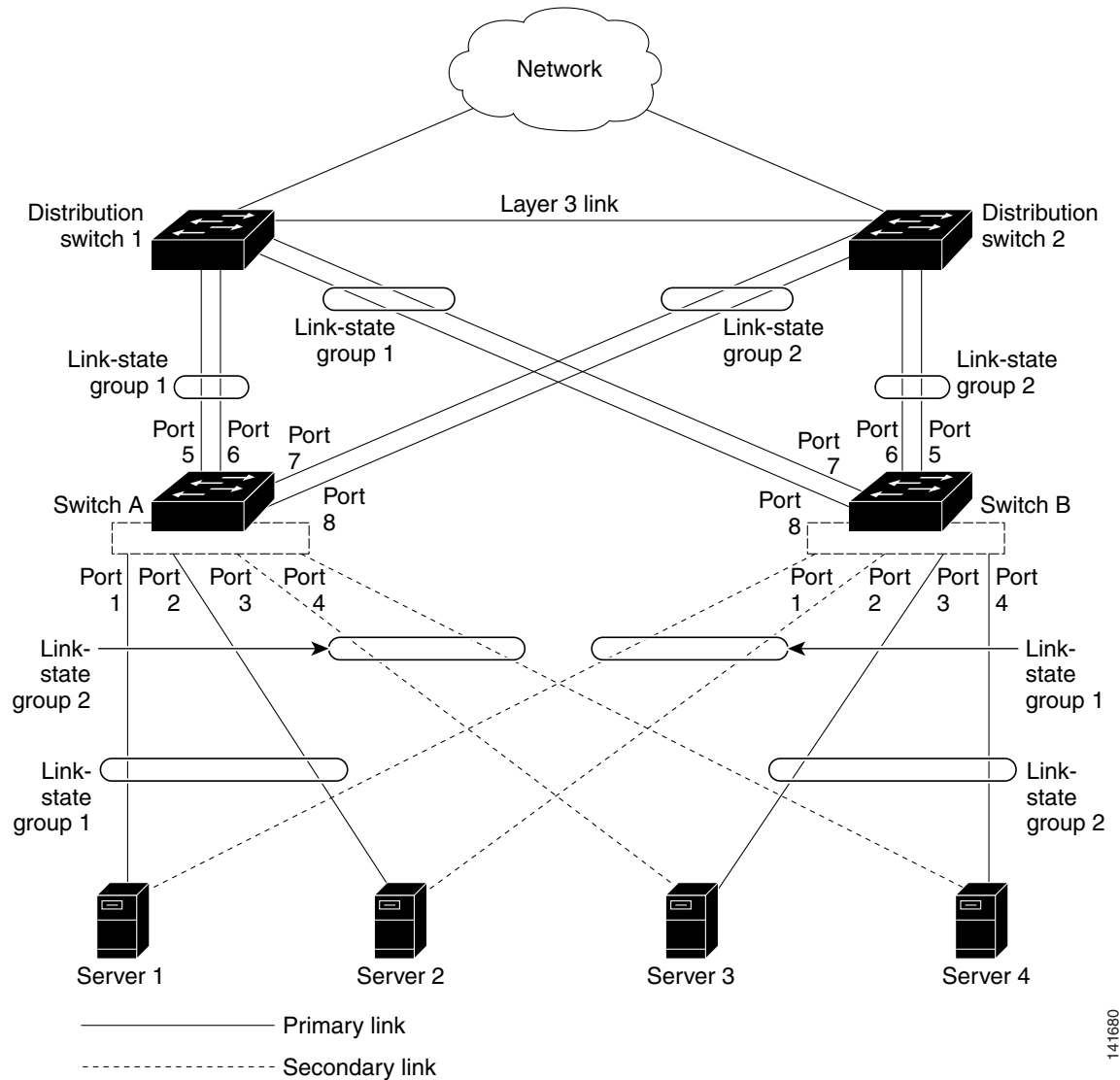

141680

Configuring Link-State Tracking

These sections describe how to configure link-state tracking ports:

- [Default Link-State Tracking Configuration, page 31-20](#)
- [Link-State Tracking Configuration Guidelines, page 31-20](#)
- [Configuring Link-State Tracking, page 31-20](#)
- [Displaying Link-State Tracking Status, page 31-21](#)

Default Link-State Tracking Configuration

There are no link-state groups defined, and link-state tracking is not enabled for any group.

Link-State Tracking Configuration Guidelines

Follow these guidelines to avoid configuration problems:

- An interface that is defined as an upstream interface cannot also be defined as a downstream interface in the same or a different link-state group. The reverse is also true.
- An interface cannot be a member of more than one link-state group.
- You can configure only two link-state groups per switch.

Configuring Link-State Tracking

Beginning in privileged EXEC mode, follow these steps to configure a link-state group and to assign an interface to a group:

	Command	Purpose
Step 1	<code>configure terminal</code>	Enter global configuration mode.
Step 2	<code>link state track <i>number</i></code>	Create a link-state group, and enable link-state tracking. The group number can be 1 to 2; the default is 1.
Step 3	<code>interface <i>interface-id</i></code>	Specify a physical interface or range of interfaces to configure, and enter interface configuration mode. Valid interfaces include switch ports in access or trunk mode (IEEE 802.1q), routed ports, or multiple ports bundled into an EtherChannel interface (static or LACP), also in trunk mode.
Step 4	<code>link state group [<i>number</i>] {upstream downstream}</code>	Specify a link-state group, and configure the interface as either an upstream or downstream interface in the group. The group number can be 1 to 2; the default is 1.
Step 5	<code>end</code>	Return to privileged EXEC mode.
Step 6	<code>show running-config</code>	Verify your entries.
Step 7	<code>copy running-config startup-config</code>	(Optional) Save your entries in the configuration file.

This example shows how to create a link-state group and configure the interfaces:

```
Switch# configure terminal
Switch(config)# link state track 1
Switch(config)# interface range gigabitethernet0/21 -22
Switch(config-if)# link state group 1 upstream
Switch(config-if)# interface gigabitethernet0/1
Switch(config-if)# link state group 1 downstream
Switch(config-if)# interface gigabitethernet0/3
Switch(config-if)# link state group 1 downstream
Switch(config-if)# interface gigabitethernet0/5
Switch(config-if)# link state group 1 downstream
Switch(config-if)# end
```

To disable a link-state group, use the **no link state track *number*** global configuration command.

Displaying Link-State Tracking Status

Use the **show link state group** command to display the link-state group information. Enter this command without keywords to display information about all link-state groups. Enter the group number to display information specific to the group. Enter the detail keyword to display detailed information about the group.

This is an example of output from the **show link state group 1** command:

```
Switch> show link state group 1
```

```
Link State Group: 1      Status: Enabled, Down
```

This is an example of output from the **show link state group detail** command:

```
Switch> show link state group detail
```

```
(Up):Interface up      (Dwn):Interface Down  (Dis):Interface disabled
```

```
Link State Group: 1 Status: Enabled, Down
```

```
Upstream Interfaces : Gi0/15(Dwn) Gi0/16(Dwn)
```

```
Downstream Interfaces : Gi0/11(Dis) Gi0/12(Dis) Gi0/13(Dis) Gi0/14(Dis)
```

```
Link State Group: 2 Status: Enabled, Down
```

```
Upstream Interfaces : Gi0/15(Dwn) Gi0/16(Dwn) Gi0/17(Dwn)
```

```
Downstream Interfaces : Gi0/11(Dis) Gi0/12(Dis) Gi0/13(Dis) Gi1/0/14(Dis)
```

```
(Up):Interface up      (Dwn):Interface Down  (Dis):Interface disabled
```

For detailed information about the fields in the display, see the command reference for this release.



CHAPTER 32

Troubleshooting

This chapter describes how to identify and resolve software problems related to the Cisco IOS software on the Catalyst 2960 switch. Depending on the nature of the problem, you can use the command-line interface (CLI), the device manager, or Network Assistant to identify and solve problems.

Additional troubleshooting information, such as LED descriptions, is provided in the hardware installation guide.



Note

For complete syntax and usage information for the commands used in this chapter, see the command reference for this release and the *Cisco IOS Commands Master List, Release 12.2* from the Cisco.com page under **Documentation > Cisco IOS Software > 12.2 Mainline > Command References**.

This chapter consists of these sections:

- [Recovering from a Software Failure, page 32-2](#)
- [Recovering from a Lost or Forgotten Password, page 32-3](#)
- [Recovering from a Command Switch Failure, page 32-7](#)
- [Recovering from Lost Cluster Member Connectivity, page 32-11](#)



Note Recovery procedures require that you have physical access to the switch.

- [Preventing Autonegotiation Mismatches, page 32-11](#)
- [SFP Module Security and Identification, page 32-12](#)
- [Monitoring SFP Module Status, page 32-12](#)
- [Using Ping, page 32-12](#)
- [Using Layer 2 Traceroute, page 32-14](#)
- [Using IP Traceroute, page 32-15](#)
- [Using TDR, page 32-17](#)
- [Using Debug Commands, page 32-18](#)
- [Using the show platform forward Command, page 32-20](#)
- [Using the crashinfo Files, page 32-21](#)

Recovering from a Software Failure

Switch software can be corrupted during an upgrade, by downloading the wrong file to the switch, and by deleting the image file. In all of these cases, the switch does not pass the power-on self-test (POST), and there is no connectivity.

This procedure uses the Xmodem Protocol to recover from a corrupt or wrong image file. There are many software packages that support the Xmodem Protocol, and this procedure is largely dependent on the emulation software that you are using.

This recovery procedure requires that you have physical access to the switch.

Step 1 From your PC, download the software image tar file (*image_filename.tar*) from Cisco.com.

The Cisco IOS image is stored as a bin file in a directory in the tar file. For information about locating the software image files on Cisco.com, see the release notes.

Step 2 Extract the bin file from the tar file.

- If you are using Windows, use a zip program that can read a tar file. Use the zip program to navigate to and extract the bin file.
- If you are using UNIX, follow these steps:
 1. Display the contents of the tar file by using the `tar -tvf <image_filename.tar>` UNIX command.

```
switch% tar -tvf image_filename.tar
```

2. Locate the bin file, and extract it by using the `tar -xvf <image_filename.tar> <image_filename.bin>` UNIX command.

```
switch% tar -xvf image_filename.tar image_filename.bin
x c2960-lanbase-mz.122-25FX/c2960-lanbase-mz.122-25.FX.bin, 2928176 bytes, 5720
tape blocks
```

3. Verify that the bin file was extracted by using the `ls -l <image_filename.bin>` UNIX command.

```
switch% ls -l image_filename.bin
-rw-r--r--  1 boba      2928176 Apr 21 12:01
c2960-lanbase-mz.122-25.FX/c2960-lanbase-mz.122-25.FX.bin
```

Step 3 Connect your PC with terminal-emulation software supporting the Xmodem Protocol to the switch console port.

Step 4 Set the line speed on the emulation software to 9600 baud.

Step 5 Unplug the switch power cord.

Step 6 Press the **Mode** button and at the same time, reconnect the power cord to the switch.

You can release the **Mode** button a second or two after the LED above port 1 goes off. Several lines of information about the software appear along with instructions:

```
The system has been interrupted prior to initializing the flash file system. The following
commands will initialize the flash file system, and finish loading the operating system
software#
```

```
flash_init
load_helper
boot
```

Step 7 Initialize the flash file system:

```
switch: flash_init
```

- Step 8** If you had set the console port speed to anything other than 9600, it has been reset to that particular speed. Change the emulation software line speed to match that of the switch console port.
- Step 9** Load any helper files:
`switch: load_helper`
- Step 10** Start the file transfer by using the Xmodem Protocol.
`switch: copy xmodem: flash:image_filename.bin`
- Step 11** After the Xmodem request appears, use the appropriate command on the terminal-emulation software to start the transfer and to copy the software image into flash memory.
- Step 12** Boot the newly downloaded Cisco IOS image.
`switch:boot flash:image_filename.bin`
- Step 13** Use the **archive download-sw** privileged EXEC command to download the software image to the switch.
- Step 14** Use the **reload** privileged EXEC command to restart the switch and to verify that the new software image is operating properly.
- Step 15** Delete the `flash:image_filename.bin` file from the switch.
-

Recovering from a Lost or Forgotten Password

The default configuration for the switch allows an end user with physical access to the switch to recover from a lost password by interrupting the boot process during power-on and by entering a new password. These recovery procedures require that you have physical access to the switch.



Note

On these switches, a system administrator can disable some of the functionality of this feature by allowing an end user to reset a password only by agreeing to return to the default configuration. If you are an end user trying to reset a password when password recovery has been disabled, a status message shows this during the recovery process.

These sections describes how to recover a forgotten or lost switch password:

- [Procedure with Password Recovery Enabled, page 32-4](#)
- [Procedure with Password Recovery Disabled, page 32-6](#)

You enable or disable password recovery by using the **service password-recovery** global configuration command. Follow the steps in this procedure if you have forgotten or lost the switch password.

- Step 1** Connect a terminal or PC with terminal-emulation software to the switch console port.
- Step 2** Set the line speed on the emulation software to 9600 baud.
- Step 3** Power off the switch.
- Step 4** Reconnect the power cord to the switch and, within 15 seconds, press the **Mode** button while the System LED is still flashing green. Continue pressing the **Mode** button until the System LED turns briefly amber and then solid green; then release the **Mode** button.

Several lines of information about the software appear with instructions, informing you if the password recovery procedure has been disabled or not.

- If you see a message that begins with this:

```
The system has been interrupted prior to initializing the flash file system. The
following commands will initialize the flash file system
```

go to the [“Procedure with Password Recovery Enabled” section on page 32-4](#), and follow the steps.

- If you see a message that begins with this:

```
The password-recovery mechanism has been triggered, but is currently disabled.
```

go to the [“Procedure with Password Recovery Disabled” section on page 32-6](#), and follow the steps.

- Step 5** After recovering the password, reload the switch:

```
Switch> reload

Proceed with reload? [confirm] y
```

Procedure with Password Recovery Enabled

If the password-recovery mechanism is enabled, this message appears:

```
The system has been interrupted prior to initializing the flash file system. The following
commands will initialize the flash file system, and finish loading the operating system
software:
```

```
flash_init
load_helper
boot
```

- Step 1** Initialize the flash file system:

```
switch: flash_init
```

- Step 2** If you had set the console port speed to anything other than 9600, it has been reset to that particular speed. Change the emulation software line speed to match that of the switch console port.

- Step 3** Load any helper files:

```
switch: load_helper
```

- Step 4** Display the contents of flash memory:

```
switch: dir flash:
```

The switch file system appears:

```
Directory of flash:
 13 drwx          192  Mar 01 1993 22:30:48 c2960-lanbase-mz.122-25.FX
 11 -rwx          5825  Mar 01 1993 22:31:59 config.text
 18 -rwx           720   Mar 01 1993 02:21:30 vlan.dat
```

```
16128000 bytes total (10003456 bytes free)
```

- Step 5** Rename the configuration file to config.text.old.

This file contains the password definition.

```
switch: rename flash:config.text flash:config.text.old
```

Step 6 Boot up the system:

```
switch: boot
```

You are prompted to start the setup program. Enter **N** at the prompt:

```
Continue with the configuration dialog? [yes/no]: N
```

Step 7 At the switch prompt, enter privileged EXEC mode:

```
Switch> enable
```

Step 8 Rename the configuration file to its original name:

```
Switch# rename flash:config.text.old flash:config.text
```

Step 9 Copy the configuration file into memory:

```
Switch# copy flash:config.text system:running-config  
Source filename [config.text]?  
Destination filename [running-config]?
```

Press **Return** in response to the confirmation prompts.

The configuration file is now reloaded, and you can change the password.

Step 10 Enter global configuration mode:

```
Switch# configure terminal
```

Step 11 Change the password:

```
Switch (config)# enable secret password
```

The secret password can be from 1 to 25 alphanumeric characters, can start with a number, is case sensitive, and allows spaces but ignores leading spaces.

Step 12 Return to privileged EXEC mode:

```
Switch (config)# exit  
Switch#
```

Step 13 Write the running configuration to the startup configuration file:

```
Switch# copy running-config startup-config
```

The new password is now in the startup configuration.



Note This procedure is likely to leave your switch virtual interface in a shutdown state. You can see which interface is in this state by entering the **show running-config** privileged EXEC command. To re-enable the interface, enter the **interface vlan *vlan-id*** global configuration command, and specify the VLAN ID of the shutdown interface. With the switch in interface configuration mode, enter the **no shutdown** command.

Step 14 Reload the switch:

```
Switch# reload
```

Procedure with Password Recovery Disabled

If the password-recovery mechanism is disabled, this message appears:

```
The password-recovery mechanism has been triggered, but
is currently disabled. Access to the boot loader prompt
through the password-recovery mechanism is disallowed at
this point. However, if you agree to let the system be
reset back to the default system configuration, access
to the boot loader prompt can still be allowed.
```

```
Would you like to reset the system back to the default configuration (y/n)?
```



Caution

Returning the switch to the default configuration results in the loss of all existing configurations. We recommend that you contact your system administrator to verify if there are backup switch and VLAN configuration files.

- If you enter **n** (no), the normal boot process continues as if the **Mode** button had not been pressed; you cannot access the boot loader prompt, and you cannot enter a new password. You see the message:

```
Press Enter to continue.....
```

- If you enter **y** (yes), the configuration file in flash memory and the VLAN database file are deleted. When the default configuration loads, you can reset the password.

Step 1 Elect to continue with password recovery and lose the existing configuration:

```
Would you like to reset the system back to the default configuration (y/n)? Y
```

Step 2 Load any helper files:

```
Switch: load_helper
```

Step 3 Display the contents of flash memory:

```
switch: dir flash:
```

The switch file system appears:

```
Directory of flash:
13  drwx          192   Mar 01 1993 22:30:48 c2960-lanbase-mz.122-25.FX.0

16128000 bytes total (10003456 bytes free)
```

Step 4 Boot up the system:

```
Switch: boot
```

You are prompted to start the setup program. To continue with password recovery, enter **N** at the prompt:

```
Continue with the configuration dialog? [yes/no]: N
```

Step 5 At the switch prompt, enter privileged EXEC mode:

```
Switch> enable
```

Step 6 Enter global configuration mode:

```
Switch# configure terminal
```

Step 7 Change the password:

```
Switch (config)# enable secret password
```

The secret password can be from 1 to 25 alphanumeric characters, can start with a number, is case sensitive, and allows spaces but ignores leading spaces.

Step 8 Return to privileged EXEC mode:

```
Switch (config)# exit
Switch#
```

Step 9 Write the running configuration to the startup configuration file:

```
Switch# copy running-config startup-config
```

The new password is now in the startup configuration.



Note This procedure is likely to leave your switch virtual interface in a shutdown state. You can see which interface is in this state by entering the **show running-config** privileged EXEC command. To re-enable the interface, enter the **interface vlan *vlan-id*** global configuration command, and specify the VLAN ID of the shutdown interface. With the switch in interface configuration mode, enter the **no shutdown** command.

Step 10 You must now reconfigure the switch. If the system administrator has the backup switch and VLAN configuration files available, you should use those.

Recovering from a Command Switch Failure

This section describes how to recover from a failed command switch. You can configure a redundant command switch group by using the Hot Standby Router Protocol (HSRP). For more information, see [Chapter 5, “Clustering Switches.”](#) Also see the *Getting Started with Cisco Network Assistant*, available on Cisco.com.

**Note**

HSRP is the preferred method for supplying redundancy to a cluster.

If you have not configured a standby command switch, and your command switch loses power or fails in some other way, management contact with the member switches is lost, and you must install a new command switch. However, connectivity between switches that are still connected is not affected, and the member switches forward packets as usual. You can manage the members as standalone switches through the console port, or, if they have IP addresses, through the other management interfaces.

You can prepare for a command switch failure by assigning an IP address to a member switch or another switch that is command-capable, making a note of the command-switch password, and cabling your cluster to provide redundant connectivity between the member switches and the replacement command switch. These sections describe two solutions for replacing a failed command switch:

- [Replacing a Failed Command Switch with a Cluster Member, page 32-8](#)
- [Replacing a Failed Command Switch with Another Switch, page 32-10](#)

These recovery procedures require that you have physical access to the switch.

For information on command-capable switches, see the release notes.

Replacing a Failed Command Switch with a Cluster Member

To replace a failed command switch with a command-capable member in the same cluster, follow these steps:

-
- Step 1** Disconnect the command switch from the member switches, and physically remove it from the cluster.
- Step 2** Insert the member switch in place of the failed command switch, and duplicate its connections to the cluster members.
- Step 3** Start a CLI session on the new command switch.
- You can access the CLI by using the console port or, if an IP address has been assigned to the switch, by using Telnet. For details about using the console port, see the switch hardware installation guide.
- Step 4** At the switch prompt, enter privileged EXEC mode:
- ```
Switch> enable
Switch#
```
- Step 5** Enter the password of the *failed command switch*.
- Step 6** Enter global configuration mode.
- ```
Switch# configure terminal
Enter configuration commands, one per line. End with CNTL/Z.
```
- Step 7** Remove the member switch from the cluster.
- ```
Switch(config)# no cluster commander-address
```
- Step 8** Return to privileged EXEC mode.
- ```
Switch(config)# end
Switch#
```

- Step 9** Use the setup program to configure the switch IP information. This program prompts you for IP address information and passwords. From privileged EXEC mode, enter **setup**, and press **Return**.

```
Switch# setup
    --- System Configuration Dialog ---
Continue with configuration dialog? [yes/no]: y

At any point you may enter a question mark '?' for help.
Use ctrl-c to abort configuration dialog at any prompt.
Default settings are in square brackets '['].

Basic management setup configures only enough connectivity
for management of the system, extended setup will ask you
to configure each interface on the system

Would you like to enter basic management setup? [yes/no]:
```

- Step 10** Enter **Y** at the first prompt.

The prompts in the setup program vary depending on the member switch that you selected to be the command switch:

```
Continue with configuration dialog? [yes/no]: y
or
Configuring global parameters:
```

If this prompt does not appear, enter **enable**, and press **Return**. Enter **setup**, and press **Return** to start the setup program.

- Step 11** Respond to the questions in the setup program.

When prompted for the hostname, recall that on a command switch, the hostname is limited to 28 characters; on a member switch to 31 characters. Do not use *-n*, where *n* is a number, as the last characters in a hostname for any switch.

When prompted for the Telnet (virtual terminal) password, recall that it can be from 1 to 25 alphanumeric characters, is case sensitive, allows spaces, but ignores leading spaces.

- Step 12** When prompted for the **enable secret** and **enable** passwords, enter the passwords of the *failed command switch* again.

- Step 13** When prompted, make sure to enable the switch as the cluster command switch, and press **Return**.

- Step 14** When prompted, assign a name to the cluster, and press **Return**.

The cluster name can be 1 to 31 alphanumeric characters, dashes, or underscores.

- Step 15** After the initial configuration displays, verify that the addresses are correct.

- Step 16** If the displayed information is correct, enter **Y**, and press **Return**.

If this information is not correct, enter **N**, press **Return**, and begin again at Step 9.

- Step 17** Start your browser, and enter the IP address of the new command switch.

- Step 18** From the Cluster menu, select **Add to Cluster** to display a list of candidate switches to add to the cluster.

Replacing a Failed Command Switch with Another Switch

To replace a failed command switch with a switch that is command-capable but not part of the cluster, follow these steps:

Step 1 Insert the new switch in place of the failed command switch, and duplicate its connections to the cluster members.

Step 2 Start a CLI session on the new command switch.

You can access the CLI by using the console port or, if an IP address has been assigned to the switch, by using Telnet. For details about using the console port, see the switch hardware installation guide.

Step 3 At the switch prompt, enter privileged EXEC mode:

```
Switch> enable
Switch#
```

Step 4 Enter the password of the *failed command switch*.

Step 5 Use the setup program to configure the switch IP information.

This program prompts you for IP address information and passwords. From privileged EXEC mode, enter **setup**, and press **Return**.

```
Switch# setup
--- System Configuration Dialog ---
Continue with configuration dialog? [yes/no]: y
```

```
At any point you may enter a question mark '?' for help.
Use ctrl-c to abort configuration dialog at any prompt.
Default settings are in square brackets '[]'.
```

```
Basic management setup configures only enough connectivity
for management of the system, extended setup will ask you
to configure each interface on the system
```

```
Would you like to enter basic management setup? [yes/no]:
```

Step 6 Enter **Y** at the first prompt.

The prompts in the setup program vary depending on the switch you selected to be the command switch:

```
Continue with configuration dialog? [yes/no]: y
```

or

```
Configuring global parameters:
```

If this prompt does not appear, enter **enable**, and press **Return**. Enter **setup**, and press **Return** to start the setup program.

Step 7 Respond to the questions in the setup program.

When prompted for the hostname, recall that on a command switch, the hostname is limited to 28 characters. Do not use *-n*, where *n* is a number, as the last character in a hostname for any switch.

When prompted for the Telnet (virtual terminal) password, recall that it can be from 1 to 25 alphanumeric characters, is case sensitive, allows spaces, but ignores leading spaces.

Step 8 When prompted for the **enable secret** and **enable** passwords, enter the passwords of the *failed command switch* again.

Step 9 When prompted, make sure to enable the switch as the cluster command switch, and press **Return**.

- Step 10** When prompted, assign a name to the cluster, and press **Return**.
The cluster name can be 1 to 31 alphanumeric characters, dashes, or underscores.
- Step 11** When the initial configuration displays, verify that the addresses are correct.
- Step 12** If the displayed information is correct, enter **Y**, and press **Return**.
If this information is not correct, enter **N**, press **Return**, and begin again at Step 9.
- Step 13** Start your browser, and enter the IP address of the new command switch.
- Step 14** From the Cluster menu, select **Add to Cluster** to display a list of candidate switches to add to the cluster.
-

Recovering from Lost Cluster Member Connectivity

Some configurations can prevent the command switch from maintaining contact with member switches. If you are unable to maintain management contact with a member, and the member switch is forwarding packets normally, check for these conflicts:

- A member switch (Catalyst 3750, Catalyst 3560, Catalyst 3550, Catalyst 3500 XL, Catalyst 2970, Catalyst 2960, Catalyst 2950, Catalyst 2900 XL, Catalyst 2820, and Catalyst 1900 switch) cannot connect to the command switch through a port that is defined as a network port.
- Catalyst 3500 XL, Catalyst 2900 XL, Catalyst 2820, and Catalyst 1900 member switches must connect to the command switch through a port that belongs to the same management VLAN.
- A member switch (Catalyst 3750, Catalyst 3560, Catalyst 3550, Catalyst 2970, Catalyst 2960, Catalyst 2950, Catalyst 3500 XL, Catalyst 2900 XL, Catalyst 2820, and Catalyst 1900 switch) connected to the command switch through a secured port can lose connectivity if the port is disabled because of a security violation.

Preventing Autonegotiation Mismatches

The IEEE 802.3ab autonegotiation protocol manages the switch settings for speed (10 Mb/s, 100 Mb/s, and 1000 Mb/s, excluding SFP module ports) and duplex (half or full). There are situations when this protocol can incorrectly align these settings, reducing performance. A mismatch occurs under these circumstances:

- A manually set speed or duplex parameter is different from the manually set speed or duplex parameter on the connected port.
- A port is set to autonegotiate, and the connected port is set to full duplex with no autonegotiation.

To maximize switch performance and ensure a link, follow one of these guidelines when changing the settings for duplex and speed:

- Let both ports autonegotiate both speed and duplex.
- Manually set the speed and duplex parameters for the ports on both ends of the connection.

**Note**

If a remote device does not autonegotiate, configure the duplex settings on the two ports to match. The speed parameter can adjust itself even if the connected port does not autonegotiate.

SFP Module Security and Identification

Cisco small form-factor pluggable (SFP) modules have a serial EEPROM that contains the module serial number, the vendor name and ID, a unique security code, and cyclic redundancy check (CRC). When an SFP module is inserted in the switch, the switch software reads the EEPROM to verify the serial number, vendor name and vendor ID, and recompute the security code and CRC. If the serial number, the vendor name or vendor ID, the security code, or CRC is invalid, the software generates a security error message and places the interface in an error-disabled state.

**Note**

The security error message references the GBIC_SECURITY facility. The switch supports SFP modules and does not support GBIC modules. Although the error message text refers to GBIC interfaces and modules, the security messages actually refer to the SFP modules and module interfaces. For more information about error messages, see the system message guide for this release.

If you are using a non-Cisco SFP module, remove the SFP module from the switch, and replace it with a Cisco module. After inserting a Cisco SFP module, use the **errdisable recovery cause gbic-invalid** global configuration command to verify the port status, and enter a time interval for recovering from the error-disabled state. After the elapsed interval, the switch brings the interface out of the error-disabled state and retries the operation. For more information about the **errdisable recovery** command, see the command reference for this release.

If the module is identified as a Cisco SFP module, but the system is unable to read vendor-data information to verify its accuracy, an SFP module error message is generated. In this case, you should remove and re-insert the SFP module. If it continues to fail, the SFP module might be defective.

Monitoring SFP Module Status

You can check the physical or operational status of an SFP module by using the **show interfaces transceiver** privileged EXEC command. This command shows the operational status, such as the temperature and the current for an SFP module on a specific interface and the alarm status. You can also use the command to check the speed and the duplex settings on an SFP module. For more information, see the **show interfaces transceiver** command in the command reference for this release.

Using Ping

These sections contain this information:

- [Understanding Ping, page 32-13](#)
- [Executing Ping, page 32-13](#)

Understanding Ping

The switch supports IP ping, which you can use to test connectivity to remote hosts. Ping sends an echo request packet to an address and waits for a reply. Ping returns one of these responses:

- Normal response—The normal response (*hostname is alive*) occurs in 1 to 10 seconds, depending on network traffic.
- Destination does not respond—If the host does not respond, a *no-answer* message is returned.
- Unknown host—If the host does not exist, an *unknown host* message is returned.
- Destination unreachable—If the default gateway cannot reach the specified network, a *destination-unreachable* message is returned.
- Network or host unreachable—If there is no entry in the route table for the host or network, a *network or host unreachable* message is returned.

Executing Ping

Beginning in privileged EXEC mode, use this command to ping another device on the network from the switch:

Command	Purpose
<code>ping ip host address</code>	Ping a remote host through IP or by supplying the hostname or network address.



Note

Though other protocol keywords are available with the **ping** command, they are not supported in this release.

This example shows how to ping an IP host:

```
Switch# ping 172.20.52.3
```

```
Type escape sequence to abort.
```

```
Sending 5, 100-byte ICMP Echoes to 172.20.52.3, timeout is 2 seconds:
```

```
!!!!
```

```
Success rate is 100 percent (5/5), round-trip min/avg/max = 1/2/4 ms
```

```
Switch#
```

[Table 32-1](#) describes the possible ping character output.

Table 32-1 Ping Output Display Characters

Character	Description
!	Each exclamation point means receipt of a reply.
.	Each period means the network server timed out while waiting for a reply.
U	A destination unreachable error PDU was received.
C	A congestion experienced packet was received.
I	User interrupted test.

Table 32-1 Ping Output Display Characters (continued)

Character	Description
?	Unknown packet type.
&	Packet lifetime exceeded.

To end a ping session, enter the escape sequence (**Ctrl-^ X** by default). Simultaneously press and release the **Ctrl**, **Shift**, and **6** keys and then press the **X** key.

Using Layer 2 Traceroute

These sections contain this information:

- [Understanding Layer 2 Traceroute, page 32-14](#)
- [Usage Guidelines, page 32-14](#)
- [Displaying the Physical Path, page 32-15](#)

Understanding Layer 2 Traceroute

The Layer 2 traceroute feature allows the switch to identify the physical path that a packet takes from a source device to a destination device. Layer 2 traceroute supports only unicast source and destination MAC addresses. It finds the path by using the MAC address tables of the switches in the path. When the switch detects a device in the path that does not support Layer 2 traceroute, the switch continues to send Layer 2 trace queries and lets them time out.

The switch can only identify the path from the source device to the destination device. It cannot identify the path that a packet takes from source host to the source device or from the destination device to the destination host.

Usage Guidelines

These are the Layer 2 traceroute usage guidelines:

- Cisco Discovery Protocol (CDP) must be enabled on all the devices in the network. For Layer 2 traceroute to function properly, do not disable CDP.
For a list of switches that support Layer 2 traceroute, see the [“Usage Guidelines” section on page 32-14](#). If any devices in the physical path are transparent to CDP, the switch cannot identify the path through these devices. For more information about enabling CDP, see [Chapter 20, “Configuring CDP.”](#)
- A switch is reachable from another switch when you can test connectivity by using the **ping** privileged EXEC command. All switches in the physical path must be reachable from each other.
- The maximum number of hops identified in the path is ten.
- You can enter the **traceroute mac** or the **traceroute mac ip** privileged EXEC command on a switch that is not in the physical path from the source device to the destination device. All switches in the path must be reachable from this switch.

- The **traceroute mac** command output shows the Layer 2 path only when the specified source and destination MAC addresses belong to the same VLAN. If you specify source and destination MAC addresses that belong to different VLANs, the Layer 2 path is not identified, and an error message appears.
- If you specify a multicast source or destination MAC address, the path is not identified, and an error message appears.
- If the source or destination MAC address belongs to multiple VLANs, you must specify the VLAN to which both the source and destination MAC addresses belong. If the VLAN is not specified, the path is not identified, and an error message appears.
- The **traceroute mac ip** command output shows the Layer 2 path when the specified source and destination IP addresses belong to the same subnet. When you specify the IP addresses, the switch uses the Address Resolution Protocol (ARP) to associate the IP addresses with the corresponding MAC addresses and the VLAN IDs.
 - If an ARP entry exists for the specified IP address, the switch uses the associated MAC address and identifies the physical path.
 - If an ARP entry does not exist, the switch sends an ARP query and tries to resolve the IP address. If the IP address is not resolved, the path is not identified, and an error message appears.
- When multiple devices are attached to one port through hubs (for example, multiple CDP neighbors are detected on a port), the Layer 2 traceroute feature is not supported. When more than one CDP neighbor is detected on a port, the Layer 2 path is not identified, and an error message appears.
- This feature is not supported in Token Ring VLANs.

Displaying the Physical Path

You can display physical path that a packet takes from a source device to a destination device by using one of these privileged EXEC commands:

- **traceroute mac** [**interface** *interface-id*] {*source-mac-address*} [**interface** *interface-id*] {*destination-mac-address*} [**vlan** *vlan-id*] [**detail**]
- **traceroute mac ip** {*source-ip-address* | *source-hostname*} {*destination-ip-address* | *destination-hostname*} [**detail**]

For more information, see the command reference for this release.

Using IP Traceroute

These sections contain this information:

- [Understanding IP Traceroute, page 32-15](#)
- [Executing IP Traceroute, page 32-16](#)

Understanding IP Traceroute

You can use IP traceroute to identify the path that packets take through the network on a hop-by-hop basis. The command output displays all network layer (Layer 3) devices, such as routers, that the traffic passes through on the way to the destination.

Your switches can participate as the source or destination of the **traceroute** privileged EXEC command and might or might not appear as a hop in the **traceroute** command output. If the switch is the destination of the traceroute, it is displayed as the final destination in the traceroute output. Intermediate switches do not show up in the traceroute output if they are only bridging the packet from one port to another within the same VLAN. However, if the intermediate switch is a multilayer switch that is routing a particular packet, this switch shows up as a hop in the traceroute output.

The **traceroute** privileged EXEC command uses the Time To Live (TTL) field in the IP header to cause routers and servers to generate specific return messages. Traceroute starts by sending a User Datagram Protocol (UDP) datagram to the destination host with the TTL field set to 1. If a router finds a TTL value of 1 or 0, it drops the datagram and sends an Internet Control Message Protocol (ICMP) time-to-live-exceeded message to the sender. Traceroute finds the address of the first hop by examining the source address field of the ICMP time-to-live-exceeded message.

To identify the next hop, traceroute sends a UDP packet with a TTL value of 2. The first router decrements the TTL field by 1 and sends the datagram to the next router. The second router sees a TTL value of 1, discards the datagram, and returns the time-to-live-exceeded message to the source. This process continues until the TTL is incremented to a value large enough for the datagram to reach the destination host (or until the maximum TTL is reached).

To learn when a datagram reaches its destination, traceroute sets the UDP destination port number in the datagram to a very large value that the destination host is unlikely to be using. When a host receives a datagram destined to itself containing a destination port number that is unused locally, it sends an ICMP *port-unreachable* error to the source. Because all errors except port-unreachable errors come from intermediate hops, the receipt of a port-unreachable error means that this message was sent by the destination port.

Executing IP Traceroute

Beginning in privileged EXEC mode, follow this step to trace that the path packets take through the network:

Command	Purpose
traceroute ip host	Trace the path that packets take through the network.



Note

Though other protocol keywords are available with the **traceroute** privileged EXEC command, they are not supported in this release.

This example shows how to perform a **traceroute** to an IP host:

```
Switch# traceroute ip 171.9.15.10

Type escape sequence to abort.
Tracing the route to 171.69.115.10

  1 172.2.52.1 0 msec 0 msec 4 msec
  2 172.2.1.203 12 msec 8 msec 0 msec
  3 171.9.16.6 4 msec 0 msec 0 msec
  4 171.9.4.5 0 msec 4 msec 0 msec
  5 171.9.121.34 0 msec 4 msec 4 msec
  6 171.9.15.9 120 msec 132 msec 128 msec
  7 171.9.15.10 132 msec 128 msec 128 msec
Switch#
```

The display shows the hop count, the IP address of the router, and the round-trip time in milliseconds for each of the three probes that are sent.

Table 32-2 *Traceroute Output Display Characters*

Character	Description
*	The probe timed out.
?	Unknown packet type.
A	Administratively unreachable. Usually, this output means that an access list is blocking traffic.
H	Host unreachable.
N	Network unreachable.
P	Protocol unreachable.
Q	Source quench.
U	Port unreachable.

To end a trace in progress, enter the escape sequence (**Ctrl-^ X** by default). Simultaneously press and release the **Ctrl**, **Shift**, and **6** keys and then press the **X** key.

Using TDR

These sections contain this information:

- [Understanding TDR, page 32-17](#)
- [Running TDR and Displaying the Results, page 32-18](#)

Understanding TDR

You can use the Time Domain Reflector (TDR) feature to diagnose and resolve cabling problems. When running TDR, a local device sends a signal through a cable and compares the reflected signal to the initial signal.

TDR is supported only on 10/100 and 10/100/1000 copper Ethernet ports. It is not supported on SFP module ports.

TDR can detect these cabling problems:

- Open, broken, or cut twisted-pair wires—The wires are not connected to the wires from the remote device.
- Shorted twisted-pair wires—The wires are touching each other or the wires from the remote device. For example, a shorted twisted pair can occur if one wire of the twisted pair is soldered to the other wire.

If one of the twisted-pair wires is open, TDR can find the length at which the wire is open.

Use TDR to diagnose and resolve cabling problems in these situations:

- Replacing a switch
- Setting up a wiring closet
- Troubleshooting a connection between two devices when a link cannot be established or when it is not operating properly

Running TDR and Displaying the Results

To run TDR, enter the **test cable-diagnostics tdr interface** *interface-id* privileged EXEC command:

To display the results, enter the **show cable-diagnostics tdr interface** *interface-id* privileged EXEC command. For a description of the fields in the display, see the command reference for this release.

Using Debug Commands

These sections explain how you use **debug** commands to diagnose and resolve internetworking problems:

- [Enabling Debugging on a Specific Feature, page 32-18](#)
- [Enabling All-System Diagnostics, page 32-19](#)
- [Redirecting Debug and Error Message Output, page 32-19](#)



Caution

Because debugging output is assigned high priority in the CPU process, it can render the system unusable. For this reason, use **debug** commands only to troubleshoot specific problems or during troubleshooting sessions with Cisco technical support staff. It is best to use **debug** commands during periods of lower network traffic and fewer users. Debugging during these periods decreases the likelihood that increased **debug** command processing overhead will affect system use.



Note

For complete syntax and usage information for specific **debug** commands, see the command reference for this release.

Enabling Debugging on a Specific Feature

All **debug** commands are entered in privileged EXEC mode, and most **debug** commands take no arguments. For example, beginning in privileged EXEC mode, enter this command to enable the debugging for Switched Port Analyzer (SPAN):

```
Switch# debug span-session
```

The switch continues to generate output until you enter the **no** form of the command.

If you enable a **debug** command and no output appears, consider these possibilities:

- The switch might not be properly configured to generate the type of traffic you want to monitor. Use the **show running-config** command to check its configuration.
- Even if the switch is properly configured, it might not generate the type of traffic you want to monitor during the particular period that debugging is enabled. Depending on the feature you are debugging, you can use commands such as the TCP/IP **ping** command to generate network traffic.

To disable debugging of SPAN, enter this command in privileged EXEC mode:

```
Switch# no debug span-session
```

Alternately, in privileged EXEC mode, you can enter the **undebug** form of the command:

```
Switch# undebug span-session
```

To display the state of each debugging option, enter this command in privileged EXEC mode:

```
Switch# show debugging
```

Enabling All-System Diagnostics

Beginning in privileged EXEC mode, enter this command to enable all-system diagnostics:

```
Switch# debug all
```



Caution

Because debugging output takes priority over other network traffic, and because the **debug all** privileged EXEC command generates more output than any other **debug** command, it can severely diminish switch performance or even render it unusable. In virtually all cases, it is best to use more specific **debug** commands.

The **no debug all** privileged EXEC command disables all diagnostic output. Using the **no debug all** command is a convenient way to ensure that you have not accidentally left any **debug** commands enabled.

Redirecting Debug and Error Message Output

By default, the network server sends the output from **debug** commands and system error messages to the console. If you use this default, you can use a virtual terminal connection to monitor debug output instead of connecting to the console port.

Possible destinations include the console, virtual terminals, internal buffer, and UNIX hosts running a syslog server. The syslog format is compatible with 4.3 Berkeley Standard Distribution (BSD) UNIX and its derivatives.



Note

Be aware that the debugging destination you use affects system overhead. Logging messages to the console produces very high overhead, whereas logging messages to a virtual terminal produces less overhead. Logging messages to a syslog server produces even less, and logging to an internal buffer produces the least overhead of any method.

For more information about system message logging, see [Chapter 25, “Configuring System Message Logging.”](#)

Using the show platform forward Command

The output from the **show platform forward** privileged EXEC command provides some useful information about the forwarding results if a packet entering an interface is sent through the system. Depending upon the parameters entered about the packet, the output provides lookup table results and port maps used to calculate forwarding destinations, bitmaps, and egress information.



Note

For more syntax and usage information for the **show platform forward** command, see the switch command reference for this release.

Most of the information in the output from the command is useful mainly for technical support personnel, who have access to detailed information about the switch application-specific integrated circuits (ASICs). However, packet forwarding information can also be helpful in troubleshooting.

This is an example of the output from the **show platform forward** command on port 1 in VLAN 5 when the packet entering that port is addressed to unknown MAC addresses. The packet should be flooded to all other ports in VLAN 5.

```
Switch# show platform forward gigabitethernet0/1 vlan 5 1.1.1 2.2.2 ip 13.1.1.1 13.2.2.2
udp 10 20
Global Port Number:24, Asic Number:5
Src Real Vlan Id:5, Mapped Vlan Id:5

Ingress:
  Lookup                Key-Used                Index-Hit  A-Data
InptACL  40_0D020202_0D010101-00_40000014_000A0000    01FFA  03000000
L2Local  80_00050002_00020002-00_00000000_00000000    00C71  0000002B
Station Descriptor:02340000, DestIndex:0239, RewriteIndex:F005

=====
Egress:Asic 2, switch 1
Output Packets:

-----
Packet 1
  Lookup                Key-Used                Index-Hit  A-Data
OutptACL 50_0D020202_0D010101-00_40000014_000A0000    01FFE  03000000

Port      Vlan    SrcMac          DstMac          Cos  Dscpv
Gi0/1     0005   0001.0001.0001  0002.0002.0002

-----
Packet 2
  Lookup                Key-Used                Index-Hit  A-Data
OutptACL 50_0D020202_0D010101-00_40000014_000A0000    01FFE  03000000

Port      Vlan    SrcMac          DstMac          Cos  Dscpv
Gi0/2     0005   0001.0001.0001  0002.0002.0002

-----
<output truncated>
-----
Packet 10
  Lookup                Key-Used                Index-Hit  A-Data
OutptACL 50_0D020202_0D010101-00_40000014_000A0000    01FFE  03000000
Packet dropped due to failed DEJA_VU Check on Gi0/2
```

This is an example of the output when the packet coming in on port 1 in VLAN 5 is sent to an address already learned on the VLAN on another port. It should be forwarded from the port on which the address was learned.

```
Switch# show platform forward gigabitethernet0/1 vlan 5 1.1.1 0009.43a8.0145 ip 13.1.1.1
13.2.2.2 udp 10 20
Global Port Number:24, Asic Number:5
Src Real Vlan Id:5, Mapped Vlan Id:5

Ingress:
  Lookup                Key-Used                Index-Hit  A-Data
InptACL  40_0D020202_0D010101-00_40000014_000A0000    01FFA    03000000
L2Local  80_00050009_43A80145-00_00000000_00000000    00086    02010197
Station Descriptor:F0050003, DestIndex:F005, RewriteIndex:0003

=====
Egress:Asic 3, switch 1
Output Packets:

-----
Packet 1
  Lookup                Key-Used                Index-Hit  A-Data
OutptACL 50_0D020202_0D010101-00_40000014_000A0000    01FFE    03000000

Port      Vlan      SrcMac          DstMac          Cos  Dscpv
Gi0/2    0005 0001.0001.0001  0009.43A8.0145
```

Using the crashinfo Files

The crashinfo files save information that helps Cisco technical support representatives to debug problems that caused the Cisco IOS image to fail (crash). The switch writes the crash information to the console at the time of the failure. The switch creates two types of crashinfo files:

- Basic crashinfo file—The switch automatically creates this file the next time you boot up the Cisco IOS image after the failure.
- Extended crashinfo file—In Cisco IOS Release 12.2(25)SEC or later, the switch automatically creates this file when the system is failing.

Basic crashinfo Files

The information in the basic file includes the Cisco IOS image name and version that failed, a list of the processor registers, and a stack trace. You can provide this information to the Cisco technical support representative by using the **show tech-support** privileged EXEC command.

Basic crashinfo files are kept in this directory on the flash file system:

```
flash:/crashinfo/.
```

The filenames are crashinfo_*n* where *n* is a sequence number.

Each new crashinfo file that is created uses a sequence number that is larger than any previously existing sequence number, so the file with the largest sequence number describes the most recent failure. Version numbers are used instead of a timestamp because the switches do not include a real-time clock. You cannot change the name of the file that the system will use when it creates the file. However, after the

file is created, you can use the **rename** privileged EXEC command to rename it, but the contents of the renamed file will not be displayed by the **show tech-support** privileged EXEC command. You can delete crashinfo files by using the **delete** privileged EXEC command.

You can display the most recent basic crashinfo file (that is, the file with the highest sequence number at the end of its filename) by entering the **show tech-support** privileged EXEC command. You also can access the file by using any command that can copy or display files, such as the **more** or the **copy** privileged EXEC command.

Extended crashinfo Files

In Cisco IOS Release 12.2(25)SEC or later, the switch creates the extended crashinfo file when the system is failing. The information in the extended file includes additional information that can help determine the cause of the switch failure. You provide this information to the Cisco technical support representative by manually accessing the file and using the **more** or the **copy** privileged EXEC command.

Extended crashinfo files are kept in this directory on the flash file system:

```
flash:/crashinfo_ext/.
```

The filenames are `crashinfo_ext_n` where *n* is a sequence number.

You can configure the switch to not create the extended crashinfo file by using the **no exception crashinfo** global configuration command.



APPENDIX **A**

Supported MIBs

This appendix lists the supported management information base (MIBs) for this release on the Catalyst 2960 switch. It contains these sections:

- [MIB List, page A-1](#)
- [Using FTP to Access the MIB Files, page A-3](#)

MIB List

- BRIDGE-MIB



Note The BRIDGE-MIB supports the context of a single VLAN. By default, SNMP messages using the configured community string always provide information for VLAN 1. To obtain the BRIDGE-MIB information for other VLANs, for example VLAN x, use this community string in the SNMP message: configured community string @x.

- CISCO-CABLE-DIAG-MIB
- CISCO-CDP-MIB
- CISCO-CLUSTER-MIB
- CISCO-CONFIG-COPY-MIB
- CISCO-CONFIG-MAN-MIB
- CISCO-ENTITY-VENDORTYPE-OID-MIB
- CISCO-ENVMON-MIB
- CISCO-ERR-DISABLE-MIB
- CISCO-FLASH-MIB (Flash memory on all switches is modeled as removable flash memory.)
- CISCO-FTP-CLIENT-MIB
- CISCO-IGMP-FILTER-MIB
- CISCO-IMAGE-MIB
- CISCO IP-STAT-MIB
- CISCO-LAG-MIB
- CISCO-MAC-NOTIFICATION-MIB

- CISCO-MEMORY-POOL-MIB
- CISCO-PAE-MIB
- CISCO-PAGP-MIB
- CISCO-PING-MIB
- CISCO-PRODUCTS-MIB
- CISCO-PROCESS-MIB
- CISCO-RTTMON-MIB
- CISCO-SMI-MIB
- CISCO-STP-EXTENSIONS-MIB
- CISCO-SYSLOG-MIB
- CISCO-TC-MIB
- CISCO-TCP-MIB
- CISCO-UDLDP-MIB
- CISCO-VLAN-IFTABLE-RELATIONSHIP-MIB
- CISCO-VLAN-MEMBERSHIP-MIB
- CISCO-VTP-MIB
- ENTITY-MIB
- ETHERLIKE-MIB
- IEEE8021-PAE-MIB
- IEEE8023-LAG-MIB
- IF-MIB (In and out counters for VLANs are not supported.)
- INET-ADDRESS-MIB
- OLD-CISCO-CHASSIS-MIB
- OLD-CISCO-FLASH-MIB
- OLD-CISCO-INTERFACES-MIB
- OLD-CISCO-IP-MIB
- OLD-CISCO-SYS-MIB
- OLD-CISCO-TCP-MIB
- OLD-CISCO-TS-MIB
- RFC1213-MIB (Functionality is as per the agent capabilities specified in the CISCO-RFC1213-CAPABILITY.my.)
- RMON-MIB
- RMON2-MIB
- SNMP-FRAMEWORK-MIB
- SNMP-MPD-MIB
- SNMP-NOTIFICATION-MIB
- SNMP-TARGET-MIB
- SNMPv2-MIB

- TCP-MIB
- UDP-MIB

**Note**

You can also use this URL for a list of supported MIBs for the Catalyst 2960 switch: <ftp://ftp.cisco.com/pub/mibs/supportlists/cat2960/cat2960-supportlist.html> You can access other information about MIBs and Cisco products on the Cisco web site: <http://www.cisco.com/public/sw-center/netmgmt/cmtk/mibs.shtml>

Using FTP to Access the MIB Files

You can get each MIB file by using this procedure:

Step 1 Make sure that your FTP client is in passive mode.

**Note**

Some FTP clients do not support passive mode.

Step 2 Use FTP to access the server **ftp.cisco.com**.

Step 3 Log in with the username **anonymous**.

Step 4 Enter your e-mail username when prompted for the password.

Step 5 At the `ftp>` prompt, change directories to **/pub/mibs/v1** and **/pub/mibs/v2**.

Step 6 Use the `get MIB_filename` command to obtain a copy of the MIB file.



APPENDIX **B**

Working with the Cisco IOS File System, Configuration Files, and Software Images

This appendix describes how to manipulate the Catalyst 2960 switch flash file system, how to copy configuration files, and how to archive (upload and download) software images to a standalone switch.



Note

For complete syntax and usage information for the commands used in this chapter, see the switch command reference for this release and the *Cisco IOS Configuration Fundamentals Command Reference, Release 12.2* from the Cisco.com page under **Documentation > Cisco IOS Software > 12.2 Mainline > Command References**.

This appendix consists of these sections:

- [Working with the Flash File System, page B-1](#)
- [Working with Configuration Files, page B-8](#)
- [Working with Software Images, page B-23](#)

Working with the Flash File System

The flash file system is a single flash device on which you can store files. It also provides several commands to help you manage software image and configuration files. The default flash file system on the switch is named *flash:*.

These sections contain this configuration information:

- [Displaying Available File Systems, page B-2](#)
- [Setting the Default File System, page B-3](#)
- [Displaying Information about Files on a File System, page B-3](#)
- [Creating and Removing Directories, page B-4](#)
- [Copying Files, page B-4](#)
- [Deleting Files, page B-5](#)
- [Creating, Displaying, and Extracting tar Files, page B-5](#)
- [Displaying the Contents of a File, page B-7](#)

Displaying Available File Systems

To display the available file systems on your switch, use the **show file systems** privileged EXEC command as shown in this example.

```
Switch# show file systems
File Systems:
      Size(b)      Free(b)      Type  Flags  Prefixes
*    15998976     5135872     flash  rw     flash:
      -           -           opaque rw     bs:
      -           -           opaque rw     vb:
      524288      520138      nvram  rw     nvram:
      -           -           network rw     tftp:
      -           -           opaque rw     null:
      -           -           opaque rw     system:
      -           -           opaque ro     xmodem:
      -           -           opaque ro     ymodem:
```

Table B-1 show file systems Field Descriptions

Field	Value
Size(b)	Amount of memory in the file system in bytes.
Free(b)	Amount of free memory in the file system in bytes.
Type	Type of file system. flash —The file system is for a flash memory device. nvram —The file system is for a NVRAM device. opaque —The file system is a locally generated <i>pseudo</i> file system (for example, the <i>system</i>) or a download interface, such as brimux. unknown —The file system is an unknown type.
Flags	Permission for file system. ro —read-only. rw —read/write. wo —write-only.
Prefixes	Alias for file system. flash: —Flash file system. nvram: —NVRAM. null: —Null destination for copies. You can copy a remote file to null to find its size. rcp: —Remote Copy Protocol (RCP) network server. system: —Contains the system memory, including the running configuration. tftp: —TFTP network server. xmodem: —Obtain the file from a network machine by using the Xmodem protocol. ymodem: —Obtain the file from a network machine by using the Ymodem protocol.

Setting the Default File System

You can specify the file system or directory that the system uses as the default file system by using the **cd** *filesystem:* privileged EXEC command. You can set the default file system to omit the *filesystem:* argument from related commands. For example, for all privileged EXEC commands that have the optional *filesystem:* argument, the system uses the file system specified by the **cd** command.

By default, the default file system is *flash:*.

You can display the current default file system as specified by the **cd** command by using the **pwd** privileged EXEC command.

Displaying Information about Files on a File System

You can view a list of the contents of a file system before manipulating its contents. For example, before copying a new configuration file to flash memory, you might want to verify that the file system does not already contain a configuration file with the same name. Similarly, before copying a flash configuration file to another location, you might want to verify its filename for use in another command.

To display information about files on a file system, use one of the privileged EXEC commands in [Table B-2](#):

Table B-2 Commands for Displaying Information About Files

Command	Description
dir [/all] [<i>filesystem:</i>][<i>filename</i>]	Display a list of files on a file system.
show file systems	Display more information about each of the files on a file system.
show file information <i>file-url</i>	Display information about a specific file.
show file descriptors	Display a list of open file descriptors. File descriptors are the internal representations of open files. You can use this command to see if another user has a file open.

Changing Directories and Displaying the Working Directory

Beginning in privileged EXEC mode, follow these steps to change directories and display the working directory.

	Command	Purpose
Step 1	dir <i>filesystem:</i>	Display the directories on the specified file system. For <i>filesystem:</i> , use flash: for the system board flash device.
Step 2	cd <i>new_configs</i>	Change to the directory of interest. The command example shows how to change to the directory named <i>new_configs</i> .
Step 3	pwd	Display the working directory.

Creating and Removing Directories

Beginning in privileged EXEC mode, follow these steps to create and remove a directory:

	Command	Purpose
Step 1	<code>dir filesystem:</code>	Display the directories on the specified file system. For <i>filesystem:</i> , use flash: for the system board flash device.
Step 2	<code>mkdir old_configs</code>	Create a new directory. The command example shows how to create the directory named <i>old_configs</i> . Directory names are case sensitive. Directory names are limited to 45 characters between the slashes (/); the name cannot contain control characters, spaces, deletes, slashes, quotes, semicolons, or colons.
Step 3	<code>dir filesystem:</code>	Verify your entry.

To delete a directory with all its files and subdirectories, use the **delete /force /recursive filesystem:/file-url** privileged EXEC command.

Use the **/recursive** keyword to delete the named directory and all subdirectories and the files contained in it. Use the **/force** keyword to suppress the prompting that confirms a deletion of each file in the directory. You are prompted only once at the beginning of this deletion process. Use the **/force** and **/recursive** keywords for deleting old software images that were installed by using the **archive download-sw** command but are no longer needed.

For *filesystem*, use **flash:** for the system board flash device. For *file-url*, enter the name of the directory to be deleted. All the files in the directory and the directory are removed.



Caution

When files and directories are deleted, their contents cannot be recovered.

Copying Files

To copy a file from a source to a destination, use the **copy source-url destination-url** privileged EXEC command. For the source and destination URLs, you can use **running-config** and **startup-config** keyword shortcuts. For example, the **copy running-config startup-config** command saves the currently running configuration file to the NVRAM section of flash memory to be used as the configuration during system initialization.

You can also copy from special file systems (**xmodem:**, **ymodem:**) as the source for the file from a network machine that uses the Xmodem or Ymodem protocol.

Network file system URLs include **ftp:**, **rtp:**, and **tftp:** and have these syntaxes:

- FTP—**ftp:**[[/username [:password]@location]/directory]/filename
- RCP—**rtp:**[[/username@location]/directory]/filename
- TFTP—**tftp:**[[/location]/directory]/filename

Local writable file systems include flash:.

Some invalid combinations of source and destination exist. Specifically, you cannot copy these combinations:

- From a running configuration to a running configuration
- From a startup configuration to a startup configuration
- From a device to the same device (for example, the **copy flash: flash:** command is invalid)

For specific examples of using the **copy** command with configuration files, see the “Working with Configuration Files” section on page B-8.

To copy software images either by downloading a new version or by uploading the existing one, use the **archive download-sw** or the **archive upload-sw** privileged EXEC command. For more information, see the “Working with Software Images” section on page B-23.

Deleting Files

When you no longer need a file on a flash memory device, you can permanently delete it. To delete a file or directory from a specified flash device, use the **delete** [**/force**] [**/recursive**] [*filesystem:*]*/file-url* privileged EXEC command.

Use the **/recursive** keyword for deleting a directory and all subdirectories and the files contained in it. Use the **/force** keyword to suppress the prompting that confirms a deletion of each file in the directory. You are prompted only once at the beginning of this deletion process. Use the **/force** and **/recursive** keywords for deleting old software images that were installed by using the **archive download-sw** command but are no longer needed.

If you omit the *filesystem:* option, the switch uses the default device specified by the **cd** command. For *file-url*, you specify the path (directory) and the name of the file to be deleted.

When you attempt to delete any files, the system prompts you to confirm the deletion.



Caution

When files are deleted, their contents cannot be recovered.

This example shows how to delete the file *myconfig* from the default flash memory device:

```
Switch# delete myconfig
```

Creating, Displaying, and Extracting tar Files

You can create a tar file and write files into it, list the files in a tar file, and extract the files from a tar file as described in the next sections.



Note

Instead of using the **copy** privileged EXEC command or the **archive tar** privileged EXEC command, we recommend using the **archive download-sw** and **archive upload-sw** privileged EXEC commands to download and upload software image files. .

Creating a tar File

To create a tar file and write files into it, use this privileged EXEC command:

```
archive tar /create destination-url flash:/file-url
```

For *destination-url*, specify the destination URL alias for the local or network file system and the name of the tar file to create. These options are supported:

- For the local flash file system, the syntax is
flash:
- For the FTP, the syntax is
ftp:[[/username[:password]@location]/directory]/tar-filename.tar
- For the RCP, the syntax is
rcp:[[/username@location]/directory]/tar-filename.tar
- For the TFTP, the syntax is
tftp:[[/location]/directory]/tar-filename.tar

The *tar-filename.tar* is the tar file to be created.

For **flash:/file-url**, specify the location on the local flash file system from which the new tar file is created. You can also specify an optional list of files or directories within the source directory to write to the new tar file. If none are specified, all files and directories at this level are written to the newly created tar file.

This example shows how to create a tar file. This command writes the contents of the *new-configs* directory on the local flash device to a file named *saved.tar* on the TFTP server at 172.20.10.30:

```
Switch# archive tar /create tftp:172.20.10.30/saved.tar flash:/new-configs
```

Displaying the Contents of a tar File

To display the contents of a tar file on the screen, use this privileged EXEC command:

```
archive tar /table source-url
```

For *source-url*, specify the source URL alias for the local or network file system. These options are supported:

- For the local flash file system, the syntax is
flash:
- For the FTP, the syntax is
ftp:[[/username[:password]@location]/directory]/tar-filename.tar
- For the RCP, the syntax is
rcp:[[/username@location]/directory]/tar-filename.tar
- For the TFTP, the syntax is
tftp:[[/location]/directory]/tar-filename.tar

The *tar-filename.tar* is the tar file to display.

You can also limit the display of the files by specifying an optional list of files or directories after the tar file; then only those files appear. If none are specified, all files and directories appear.

This example shows how to display the contents of a switch tar file that is in flash memory:

```
Switch# archive tar /table flash:c2960-lanbase-mz.122-25.FX.tar  
info (219 bytes)  
c2960-lanbase-mz.122-25.FX/ (directory)  
c2960-lanbase-mz.122-25.FX/html/ (directory)
```

```
c2960-lanbase-mz.122-25.FX/html/foo.html (0 bytes)
c2960-lanbase-mz.122-25.FX/c2960-lanbase-mz.122-25.FX.bin (4590080 bytes)
c2960-lanbase-mz.122-25.FX/info (219 bytes)
```

This example shows how to display only the `/html` directory and its contents:

```
Switch# archive tar /table flash: c2960-lanbase-mz.12-25/html
c2960-lanbase-12-25.FX/html
c2960-lanbase-12-25.FX/html/ (directory)
c2960-lanbase-12-25.FX/html/const.htm (556 bytes)
c2960-lanbase-12-25.FX/html/xhome.htm (9373 bytes)
c2960-lanbase-12-25.FX/html/menu.css (1654 bytes)
<output truncated>
```

Extracting a tar File

To extract a tar file into a directory on the flash file system, use this privileged EXEC command:

```
archive tar /xtract source-url flash:/file-url [dir/file...]
```

For *source-url*, specify the source URL alias for the local file system. These options are supported:

- For the local flash file system, the syntax is
flash:
- For the FTP, the syntax is
ftp:[[/username[:password]@location]/directory]/tar-filename.tar
- For the RCP, the syntax is
rcp:[[/username@location]/directory]/tar-filename.tar
- For the TFTP, the syntax is
tftp:[[/location]/directory]/tar-filename.tar

The *tar-filename.tar* is the tar file from which to extract files.

For **flash:/file-url [dir/file...]**, specify the location on the local flash file system into which the tar file is extracted. Use the *dir/file...* option to specify an optional list of files or directories within the tar file to be extracted. If none are specified, all files and directories are extracted.

This example shows how to extract the contents of a tar file located on the TFTP server at 172.20.10.30. This command extracts just the *new-configs* directory into the root directory on the local flash file system. The remaining files in the *saved.tar* file are ignored.

```
Switch# archive tar /xtract tftp://172.20.10.30/saved.tar flash:/new-configs
```

Displaying the Contents of a File

To display the contents of any readable file, including a file on a remote file system, use the **more [/ascii | /binary | /ebcdic] file-url** privileged EXEC command:

This example shows how to display the contents of a configuration file on a TFTP server:

```
Switch# more tftp://serverA/hampton/savedconfig
!
! Saved configuration on server
!
version 11.3
service timestamps log datetime localtime
service linenumbers
service udp-small-servers
service pt-vty-logging
```

```
!  
<output truncated>
```

Working with Configuration Files

This section describes how to create, load, and maintain configuration files.

Configuration files contain commands entered to customize the function of the Cisco IOS software. A way to create a basic configuration file is to use the **setup** program or to enter the **setup** privileged EXEC command. For more information, see [Chapter 3, “Assigning the Switch IP Address and Default Gateway.”](#)

You can copy (*download*) configuration files from a TFTP, FTP, or RCP server to the running configuration or startup configuration of the switch. You might want to perform this for one of these reasons:

- To restore a backed-up configuration file.
- To use the configuration file for another switch. For example, you might add another switch to your network and want it to have a configuration similar to the original switch. By copying the file to the new switch, you can change the relevant parts rather than recreating the whole file.
- To load the same configuration commands on all the switches in your network so that all the switches have similar configurations.

You can copy (*upload*) configuration files from the switch to a file server by using TFTP, FTP, or RCP. You might perform this task to back up a current configuration file to a server before changing its contents so that you can later restore the original configuration file from the server.

The protocol you use depends on which type of server you are using. The FTP and RCP transport mechanisms provide faster performance and more reliable delivery of data than TFTP. These improvements are possible because FTP and RCP are built on and use the TCP/IP stack, which is connection-oriented.

These sections contain this configuration information:

- [Guidelines for Creating and Using Configuration Files, page B-8](#)
- [Configuration File Types and Location, page B-9](#)
- [Creating a Configuration File By Using a Text Editor, page B-9](#)
- [Copying Configuration Files By Using TFTP, page B-10](#)
- [Copying Configuration Files By Using FTP, page B-12](#)
- [Copying Configuration Files By Using RCP, page B-15](#)
- [Clearing Configuration Information, page B-19](#)
- [Replacing and Rolling Back Configurations, page B-19](#)

Guidelines for Creating and Using Configuration Files

Creating configuration files can aid in your switch configuration. Configuration files can contain some or all of the commands needed to configure one or more switches. For example, you might want to download the same configuration file to several switches that have the same hardware configuration.

Use these guidelines when creating a configuration file:

- We recommend that you connect through the console port for the initial configuration of the switch. If you are accessing the switch through a network connection instead of through a direct connection to the console port, keep in mind that some configuration changes (such as changing the switch IP address or disabling ports) can cause a loss of connectivity to the switch.
- If no password has been set on the switch, we recommend that you set one by using the **enable secret** *secret-password* global configuration command.

**Note**

The **copy {ftp: | rcp: | tftp:} system:running-config** privileged EXEC command loads the configuration files on the switch as if you were entering the commands at the command line. The switch does not erase the existing running configuration before adding the commands. If a command in the copied configuration file replaces a command in the existing configuration file, the existing command is erased. For example, if the copied configuration file contains a different IP address in a particular command than the existing configuration, the IP address in the copied configuration is used. However, some commands in the existing configuration might not be replaced or negated. In this case, the resulting configuration file is a mixture of the existing configuration file and the copied configuration file, with the copied configuration file having precedence.

To restore a configuration file to an exact copy of a file stored on a server, copy the configuration file directly to the startup configuration (by using the **copy {ftp: | rcp: | tftp:} nvram:startup-config** privileged EXEC command), and reload the switch.

Configuration File Types and Location

Startup configuration files are used during system startup to configure the software. Running configuration files contain the current configuration of the software. The two configuration files can be different. For example, you might want to change the configuration for a short time period rather than permanently. In this case, you would change the running configuration but not save the configuration by using the **copy running-config startup-config** privileged EXEC command.

The running configuration is saved in DRAM; the startup configuration is stored in the NVRAM section of flash memory.

Creating a Configuration File By Using a Text Editor

When creating a configuration file, you must list commands logically so that the system can respond appropriately. This is one method of creating a configuration file:

-
- Step 1** Copy an existing configuration from a switch to a server.
- For more information, see the [“Downloading the Configuration File By Using TFTP”](#) section on page B-11, the [“Downloading a Configuration File By Using FTP”](#) section on page B-13, or the [“Downloading a Configuration File By Using RCP”](#) section on page B-16.
- Step 2** Open the configuration file in a text editor, such as vi or emacs on UNIX or Notepad on a PC.
- Step 3** Extract the portion of the configuration file with the desired commands, and save it in a new file.
- Step 4** Copy the configuration file to the appropriate server location. For example, copy the file to the TFTP directory on the workstation (usually /tftpboot on a UNIX workstation).

- Step 5** Make sure the permissions on the file are set to world-read.
-

Copying Configuration Files By Using TFTP

You can configure the switch by using configuration files you create, download from another switch, or download from a TFTP server. You can copy (upload) configuration files to a TFTP server for storage.

These sections contain this configuration information:

- [Preparing to Download or Upload a Configuration File By Using TFTP, page B-10](#)
- [Downloading the Configuration File By Using TFTP, page B-11](#)
- [Uploading the Configuration File By Using TFTP, page B-11](#)

Preparing to Download or Upload a Configuration File By Using TFTP

Before you begin downloading or uploading a configuration file by using TFTP, do these tasks:

- Ensure that the workstation acting as the TFTP server is properly configured. On a Sun workstation, make sure that the `/etc/inetd.conf` file contains this line:

```
tftp dgram udp wait root /usr/etc/in.tftpd in.tftpd -p -s /tftpboot
```

Make sure that the `/etc/services` file contains this line:

```
tftp 69/udp
```



Note You must restart the `inetd` daemon after modifying the `/etc/inetd.conf` and `/etc/services` files. To restart the daemon, either stop the `inetd` process and restart it, or enter a **fastboot** command (on the SunOS 4.x) or a **reboot** command (on Solaris 2.x or SunOS 5.x). For more information on the TFTP daemon, see the documentation for your workstation.

- Ensure that the switch has a route to the TFTP server. The switch and the TFTP server must be in the same subnetwork if you do not have a router to route traffic between subnets. Check connectivity to the TFTP server by using the **ping** command.
- Ensure that the configuration file to be downloaded is in the correct directory on the TFTP server (usually `/tftpboot` on a UNIX workstation).
- For download operations, ensure that the permissions on the file are set correctly. The permission on the file should be world-read.
- Before uploading the configuration file, you might need to create an empty file on the TFTP server. To create an empty file, enter the **touch filename** command, where *filename* is the name of the file you will use when uploading it to the server.
- During upload operations, if you are overwriting an existing file (including an empty file, if you had to create one) on the server, ensure that the permissions on the file are set correctly. Permissions on the file should be world-write.

Downloading the Configuration File By Using TFTP

To configure the switch by using a configuration file downloaded from a TFTP server, follow these steps:

-
- Step 1** Copy the configuration file to the appropriate TFTP directory on the workstation.
 - Step 2** Verify that the TFTP server is properly configured by referring to the [“Preparing to Download or Upload a Configuration File By Using TFTP”](#) section on page B-10.
 - Step 3** Log into the switch through the console port or a Telnet session.
 - Step 4** Download the configuration file from the TFTP server to configure the switch.

Specify the IP address or hostname of the TFTP server and the name of the file to download.

Use one of these privileged EXEC commands:

- **copy tftp:[[/location]/directory]/filename system:running-config**
- **copy tftp:[[/location]/directory]/filename nvram:startup-config**

The configuration file downloads, and the commands are executed as the file is parsed line-by-line.

This example shows how to configure the software from the file *tokyo-config* at IP address 172.16.2.155:

```
Switch# copy tftp://172.16.2.155/tokyo-config system:running-config
Configure using tokyo-config from 172.16.2.155? [confirm] y
Booting tokyo-config from 172.16.2.155:!!! [OK - 874/16000 bytes]
```

Uploading the Configuration File By Using TFTP

To upload a configuration file from a switch to a TFTP server for storage, follow these steps:

-
- Step 1** Verify that the TFTP server is properly configured by referring to the [“Preparing to Download or Upload a Configuration File By Using TFTP”](#) section on page B-10.
 - Step 2** Log into the switch through the console port or a Telnet session.
 - Step 3** Upload the switch configuration to the TFTP server. Specify the IP address or hostname of the TFTP server and the destination filename.

Use one of these privileged EXEC commands:

- **copy system:running-config tftp:[[/location]/directory]/filename**
- **copy nvram:startup-config tftp:[[/location]/directory]/filename**

The file is uploaded to the TFTP server.

This example shows how to upload a configuration file from a switch to a TFTP server:

```
Switch# copy system:running-config tftp://172.16.2.155/tokyo-config
Write file tokyo-config on host 172.16.2.155? [confirm] y
#
Writing tokyo-config!!! [OK]
```

Copying Configuration Files By Using FTP

You can copy configuration files to or from an FTP server.

The FTP protocol requires a client to send a remote username and password on each FTP request to a server. When you copy a configuration file from the switch to a server by using FTP, the Cisco IOS software sends the first valid username in this list:

- The username specified in the **copy** command if a username is specified.
- The username set by the **ip ftp username *username*** global configuration command if the command is configured.
- Anonymous.

The switch sends the first valid password in this list:

- The password specified in the **copy** command if a password is specified.
- The password set by the **ip ftp password *password*** global configuration command if the command is configured.
- The switch forms a password named *username@switchname.domain*. The variable *username* is the username associated with the current session, *switchname* is the configured hostname, and *domain* is the domain of the switch.

The username and password must be associated with an account on the FTP server. If you are writing to the server, the FTP server must be properly configured to accept your FTP write request.

Use the **ip ftp username** and **ip ftp password** commands to specify a username and password for all copies. Include the username in the **copy** command if you want to specify only a username for that copy operation.

If the server has a directory structure, the configuration file is written to or copied from the directory associated with the username on the server. For example, if the configuration file resides in the home directory of a user on the server, specify that user's name as the remote username.

For more information, see the documentation for your FTP server.

These sections contain this configuration information:

- [Preparing to Download or Upload a Configuration File By Using FTP, page B-12](#)
- [Downloading a Configuration File By Using FTP, page B-13](#)
- [Uploading a Configuration File By Using FTP, page B-14](#)

Preparing to Download or Upload a Configuration File By Using FTP

Before you begin downloading or uploading a configuration file by using FTP, do these tasks:

- Ensure that the switch has a route to the FTP server. The switch and the FTP server must be in the same subnetwork if you do not have a router to route traffic between subnets. Check connectivity to the FTP server by using the **ping** command.
- If you are accessing the switch through the console or a Telnet session and you do not have a valid username, make sure that the current FTP username is the one that you want to use for the FTP download. You can enter the **show users** privileged EXEC command to view the valid username. If you do not want to use this username, create a new FTP username by using the **ip ftp username *username*** global configuration command during all copy operations. The new username is stored in

NVRAM. If you are accessing the switch through a Telnet session and you have a valid username, this username is used, and you do not need to set the FTP username. Include the username in the **copy** command if you want to specify a username for only that copy operation.

- When you upload a configuration file to the FTP server, it must be properly configured to accept the write request from the user on the switch.

For more information, see the documentation for your FTP server.

Downloading a Configuration File By Using FTP

Beginning in privileged EXEC mode, follow these steps to download a configuration file by using FTP:

	Command	Purpose
Step 1		Verify that the FTP server is properly configured by referring to the “Preparing to Download or Upload a Configuration File By Using FTP” section on page B-12.
Step 2		Log into the switch through the console port or a Telnet session.
Step 3	configure terminal	Enter global configuration mode on the switch. This step is required only if you override the default remote username or password (see Steps 4, 5, and 6).
Step 4	ip ftp username <i>username</i>	(Optional) Change the default remote username.
Step 5	ip ftp password <i>password</i>	(Optional) Change the default password.
Step 6	end	Return to privileged EXEC mode.
Step 7	copy ftp:[[/[username[:password]@]location/]directory] /filename] system:running-config or copy ftp:[[/[username[:password]@]location/]directory] /filename] nvram:startup-config	Using FTP, copy the configuration file from a network server to the running configuration or to the startup configuration file.

This example shows how to copy a configuration file named *host1-config* from the *netadmin1* directory on the remote server with an IP address of 172.16.101.101 and to load and run those commands on the switch:

```
Switch# copy ftp://netadmin1:mypass@172.16.101.101/host1-config system:running-config
Configure using host1-config from 172.16.101.101? [confirm]
Connected to 172.16.101.101
Loading 1112 byte file host1-config:[OK]
Switch#
%SYS-5-CONFIG: Configured from host1-config by ftp from 172.16.101.101
```

This example shows how to specify a remote username of *netadmin1*. The software copies the configuration file *host2-config* from the *netadmin1* directory on the remote server with an IP address of 172.16.101.101 to the switch startup configuration.

```
Switch# configure terminal
Switch(config)# ip ftp username netadmin1
Switch(config)# ip ftp password mypass
Switch(config)# end
```

```
Switch# copy ftp: nvram:startup-config
Address of remote host [255.255.255.255]? 172.16.101.101
Name of configuration file[rtr2-config]? host2-config
Configure using host2-config from 172.16.101.101?[confirm]
Connected to 172.16.101.101
Loading 1112 byte file host2-config:[OK]
[OK]
Switch#
%SYS-5-CONFIG_NV:Non-volatile store configured from host2-config by ftp from
172.16.101.101
```

Uploading a Configuration File By Using FTP

Beginning in privileged EXEC mode, follow these steps to upload a configuration file by using FTP:

	Command	Purpose
Step 1		Verify that the FTP server is properly configured by referring to the “Preparing to Download or Upload a Configuration File By Using FTP” section on page B-12.
Step 2		Log into the switch through the console port or a Telnet session.
Step 3	configure terminal	Enter global configuration mode. This step is required only if you override the default remote username or password (see Steps 4, 5, and 6).
Step 4	ip ftp username <i>username</i>	(Optional) Change the default remote username.
Step 5	ip ftp password <i>password</i>	(Optional) Change the default password.
Step 6	end	Return to privileged EXEC mode.
Step 7	copy system:running-config ftp:[[[//[username[:password]@]location]/directory]/filename] or copy nvram:startup-config ftp:[[[//[username[:password]@]location]/directory]/filename]	Using FTP, store the switch running or startup configuration file to the specified location.

This example shows how to copy the running configuration file named *switch2-config* to the *netadmin1* directory on the remote host with an IP address of 172.16.101.101:

```
Switch# copy system:running-config ftp://netadmin1:mypass@172.16.101.101/switch2-config
Write file switch2-config on host 172.16.101.101?[confirm]
Building configuration...[OK]
Connected to 172.16.101.101
Switch#
```

This example shows how to store a startup configuration file on a server by using FTP to copy the file:

```
Switch# configure terminal
Switch(config)# ip ftp username netadmin2
Switch(config)# ip ftp password mypass
Switch(config)# end
Switch# copy nvram:startup-config ftp:
Remote host[ ]? 172.16.101.101
```

```
Name of configuration file to write [switch2-config]?
Write file switch2-config on host 172.16.101.101?[confirm]
![OK]
```

Copying Configuration Files By Using RCP

The RCP provides another method of downloading, uploading, and copying configuration files between remote hosts and the switch. Unlike TFTP, which uses User Datagram Protocol (UDP), a connectionless protocol, RCP uses TCP, which is connection-oriented.

To use RCP to copy files, the server from or to which you will be copying files must support RCP. The RCP copy commands rely on the rsh server (or daemon) on the remote system. To copy files by using RCP, you do not need to create a server for file distribution as you do with TFTP. You only need to have access to a server that supports the remote shell (rsh). (Most UNIX systems support rsh.) Because you are copying a file from one place to another, you must have read permission on the source file and write permission on the destination file. If the destination file does not exist, RCP creates it for you.

The RCP requires a client to send a remote username with each RCP request to a server. When you copy a configuration file from the switch to a server, the Cisco IOS software sends the first valid username in this list:

- The username specified in the **copy** command if a username is specified.
- The username set by the **ip rcmd remote-username *username*** global configuration command if the command is configured.
- The remote username associated with the current TTY (terminal) process. For example, if the user is connected to the router through Telnet and was authenticated through the **username** command, the switch software sends the Telnet username as the remote username.
- The switch hostname.

For a successful RCP copy request, you must define an account on the network server for the remote username. If the server has a directory structure, the configuration file is written to or copied from the directory associated with the remote username on the server. For example, if the configuration file is in the home directory of a user on the server, specify that user's name as the remote username.

These sections contain this configuration information:

- [Preparing to Download or Upload a Configuration File By Using RCP, page B-15](#)
- [Downloading a Configuration File By Using RCP, page B-16](#)
- [Uploading a Configuration File By Using RCP, page B-17](#)

Preparing to Download or Upload a Configuration File By Using RCP

Before you begin downloading or uploading a configuration file by using RCP, do these tasks:

- Ensure that the workstation acting as the RCP server supports the remote shell (rsh).
- Ensure that the switch has a route to the RCP server. The switch and the server must be in the same subnetwork if you do not have a router to route traffic between subnets. Check connectivity to the RCP server by using the **ping** command.
- If you are accessing the switch through the console or a Telnet session and you do not have a valid username, make sure that the current RCP username is the one that you want to use for the RCP download. You can enter the **show users** privileged EXEC command to view the valid username. If you do not want to use this username, create a new RCP username by using the **ip rcmd remote-username *username*** global configuration command to be used during all copy operations.

The new username is stored in NVRAM. If you are accessing the switch through a Telnet session and you have a valid username, this username is used, and you do not need to set the RCP username. Include the username in the **copy** command if you want to specify a username for only that copy operation.

- When you upload a file to the RCP server, it must be properly configured to accept the RCP write request from the user on the switch. For UNIX systems, you must add an entry to the `.rhosts` file for the remote user on the RCP server. For example, suppose that the switch contains these configuration lines:

```
hostname Switch1
ip rcmd remote-username User0
```

If the switch IP address translates to `Switch1.company.com`, the `.rhosts` file for User0 on the RCP server should contain this line:

```
Switch1.company.com Switch1
```

For more information, see the documentation for your RCP server.

Downloading a Configuration File By Using RCP

Beginning in privileged EXEC mode, follow these steps to download a configuration file by using RCP:

	Command	Purpose
Step 1		Verify that the RCP server is properly configured by referring to the “Preparing to Download or Upload a Configuration File By Using RCP” section on page B-15.
Step 2		Log into the switch through the console port or a Telnet session.
Step 3	configure terminal	Enter global configuration mode. This step is required only if you override the default remote username (see Steps 4 and 5).
Step 4	ip rcmd remote-username <i>username</i>	(Optional) Specify the remote username.
Step 5	end	Return to privileged EXEC mode.
Step 6	copy rcp:[[[//[username@]location]/directory]/filename] system:running-config or copy rcp:[[[//[username@]location]/directory]/filename] nvrाम:startup-config	Using RCP, copy the configuration file from a network server to the running configuration or to the startup configuration file.

This example shows how to copy a configuration file named `host1-config` from the `netadmin1` directory on the remote server with an IP address of 172.16.101.101 and load and run those commands on the switch:

```
Switch# copy rcp://netadmin1@172.16.101.101/host1-config system:running-config
Configure using host1-config from 172.16.101.101? [confirm]
Connected to 172.16.101.101
Loading 1112 byte file host1-config:![OK]
Switch#
```

```
%SYS-5-CONFIG: Configured from host1-config by rcp from 172.16.101.101
```

This example shows how to specify a remote username of *netadmin1*. Then it copies the configuration file *host2-config* from the *netadmin1* directory on the remote server with an IP address of 172.16.101.101 to the startup configuration:

```
Switch# configure terminal
Switch(config)# ip rcmd remote-username netadmin1
Switch(config)# end
Switch# copy rcp: nvram:startup-config
Address of remote host [255.255.255.255]? 172.16.101.101
Name of configuration file[rtr2-config]? host2-config
Configure using host2-config from 172.16.101.101?[confirm]
Connected to 172.16.101.101
Loading 1112 byte file host2-config:![OK]
[OK]
Switch#
%SYS-5-CONFIG_NV:Non-volatile store configured from host2-config by rcp from
172.16.101.101
```

Uploading a Configuration File By Using RCP

Beginning in privileged EXEC mode, follow these steps to upload a configuration file by using RCP:

	Command	Purpose
Step 1		Verify that the RCP server is properly configured by referring to the “Preparing to Download or Upload a Configuration File By Using RCP” section on page B-15.
Step 2		Log into the switch through the console port or a Telnet session.
Step 3	configure terminal	Enter global configuration mode. This step is required only if you override the default remote username (see Steps 4 and 5).
Step 4	ip rcmd remote-username <i>username</i>	(Optional) Specify the remote username.
Step 5	end	Return to privileged EXEC mode.
Step 6	copy system:running-config rcp:[[[//[<i>username</i>@]<i>location</i>]/<i>directory</i>]/<i>filename</i>] or copy nvram:startup-config rcp:[[[//[<i>username</i>@]<i>location</i>]/<i>directory</i>]/<i>filename</i>]	Using RCP, copy the configuration file from a switch running or startup configuration file to a network server.

This example shows how to copy the running configuration file named *switch2-config* to the *netadmin1* directory on the remote host with an IP address of 172.16.101.101:

```
Switch# copy system:running-config rcp://netadmin1@172.16.101.101/switch2-config
Write file switch-config on host 172.16.101.101?[confirm]
Building configuration...[OK]
Connected to 172.16.101.101
Switch#
```

This example shows how to store a startup configuration file on a server:

```
Switch# configure terminal
```

```
Switch(config)# ip rcmd remote-username netadmin2
Switch(config)# end
Switch# copy nvram:startup-config rcp:
Remote host[]? 172.16.101.101
Name of configuration file to write [switch2-config]?
Write file switch2-config on host 172.16.101.101?[confirm]
![OK]
```

Clearing Configuration Information

You can clear the configuration information from the startup configuration. If you reboot the switch with no startup configuration, the switch enters the setup program so that you can reconfigure the switch with all new settings.

Clearing the Startup Configuration File

To clear the contents of your startup configuration, use the **erase nvram:** or the **erase startup-config** privileged EXEC command.



Caution

You cannot restore the startup configuration file after it has been deleted.

Deleting a Stored Configuration File

To delete a saved configuration from flash memory, use the **delete flash:filename** privileged EXEC command. Depending on the setting of the **file prompt** global configuration command, you might be prompted for confirmation before you delete a file. By default, the switch prompts for confirmation on destructive file operations. For more information about the **file prompt** command, see the *Cisco IOS Command Reference for Release 12.2*.



Caution

You cannot restore a file after it has been deleted.

Replacing and Rolling Back Configurations

The configuration replacement and rollback feature replaces the running configuration with any saved Cisco IOS configuration file. You can use the rollback function to roll back to a previous configuration.

These sections contain this information:

- [Understanding Configuration Replacement and Rollback, page B-19](#)
- [Configuration Guidelines, page B-21](#)
- [Configuring the Configuration Archive, page B-21](#)
- [Performing a Configuration Replacement or Rollback Operation, page B-22](#)

Understanding Configuration Replacement and Rollback

To use the configuration replacement and rollback feature, you should understand these concepts:

- [Archiving a Configuration, page B-20](#)
- [Replacing a Configuration, page B-20](#)
- [Rolling Back a Configuration, page B-20](#)

Archiving a Configuration

The configuration archive provides a mechanism to store, organize, and manage an archive of configuration files. The **configure replace** privileged EXEC command increases the configuration rollback capability. As an alternative, you can save copies of the running configuration by using the **copy running-config destination-url** privileged EXEC command, storing the replacement file either locally or remotely. However, this method lacks any automated file management. The configuration replacement and rollback feature can automatically save copies of the running configuration to the configuration archive.

You use the **archive config** privileged EXEC command to save configurations in the configuration archive by using a standard location and filename prefix that is automatically appended with an incremental version number (and optional timestamp) as each consecutive file is saved. You can specify how many versions of the running configuration are kept in the archive. After the maximum number of files are saved, the oldest file is automatically deleted when the next, most recent file is saved. The **show archive** privileged EXEC command displays information for all the configuration files saved in the configuration archive.

The Cisco IOS configuration archive, in which the configuration files are stored and available for use with the **configure replace** command, is in any of these file systems: FTP, HTTP, RCP, TFTP.

Replacing a Configuration

The **configure replace** privileged EXEC command replaces the running configuration with any saved configuration file. When you enter the **configure replace** command, the running configuration is compared with the specified replacement configuration, and a set of configuration differences is generated. The resulting differences are used to replace the configuration. The configuration replacement operation is usually completed in no more than three passes. To prevent looping behavior no more than five passes are performed.

You can use the **copy source-url running-config** privileged EXEC command to copy a stored configuration file to the running configuration. When using this command as an alternative to the **configure replace target-url** privileged EXEC command, note these major differences:

- The **copy source-url running-config** command is a merge operation and preserves all the commands from both the source file and the running configuration. This command does not remove commands from the running configuration that are not present in the source file. In contrast, the **configure replace target-url** command removes commands from the running configuration that are not present in the replacement file and adds commands to the running configuration that are not present.
- You can use a partial configuration file as the source file for the **copy source-url running-config** command. You must use a complete configuration file as the replacement file for the **configure replace target-url** command.

Rolling Back a Configuration

You can also use the **configure replace** command to roll back changes that were made since the previous configuration was saved. Instead of basing the rollback operation on a specific set of changes that were applied, the configuration rollback capability reverts to a specific configuration based on a saved configuration file.

If you want the configuration rollback capability, you must first save the running configuration before making any configuration changes. Then, after entering configuration changes, you can use that saved configuration file to roll back the changes by using the **configure replace target-url** command.

You can specify any saved configuration file as the rollback configuration. You are not limited to a fixed number of rollbacks, as is the case in some rollback models.

Configuration Guidelines

Follow these guidelines when configuring and performing configuration replacement and rollback:

- Make sure that the switch has free memory larger than the combined size of the two configuration files (the running configuration and the saved replacement configuration). Otherwise, the configuration replacement operation fails.
- Make sure that the switch also has sufficient free memory to execute the configuration replacement or rollback configuration commands.
- Certain configuration commands, such as those pertaining to physical components of a networking device (for example, physical interfaces), cannot be added or removed from the running configuration.
 - A configuration replacement operation cannot remove the **interface** *interface-id* command line from the running configuration if that interface is physically present on the device.
 - The **interface** *interface-id* command line cannot be added to the running configuration if no such interface is physically present on the device.
- When using the **configure replace** command, you must specify a saved configuration as the replacement configuration file for the running configuration. The replacement file must be a complete configuration generated by a Cisco IOS device (for example, a configuration generated by the **copy running-config destination-url** command).



Note

If you generate the replacement configuration file externally, it must comply with the format of files generated by Cisco IOS devices.

Configuring the Configuration Archive

Using the **configure replace** command with the configuration archive and with the **archive config** command is optional but offers significant benefit for configuration rollback scenarios. Before using the **archive config** command, you must first configure the configuration archive. Starting in privileged EXEC mode, follow these steps to configure the configuration archive:

	Command	Purpose
Step 1	configure terminal	Enter global configuration mode.
Step 2	archive	Enter archive configuration mode.
Step 3	path url	Specify the location and filename prefix for the files in the configuration archive.
Step 4	maximum number	<p>(Optional) Set the maximum number of archive files of the running configuration to be saved in the configuration archive.</p> <p><i>number</i>—Maximum files of the running configuration file in the configuration archive. Valid values are from 1 to 14. The default is 10.</p> <p>Note Before using this command, you must first enter the path archive configuration command to specify the location and filename prefix for the files in the configuration archive.</p>

	Command	Purpose
Step 5	time-period <i>minutes</i>	(Optional) Set the time increment for automatically saving an archive file of the running configuration in the configuration archive. <i>minutes</i> —Specify how often, in minutes, to automatically save an archive file of the running configuration in the configuration archive.
Step 6	end	Return to privileged EXEC mode.
Step 7	show running-config	Verify the configuration.
Step 8	copy running-config startup-config	(Optional) Save your entries in the configuration file.

Performing a Configuration Replacement or Rollback Operation

Starting in privileged EXEC mode, follow these steps to replace the running configuration file with a saved configuration file:

	Command	Purpose
Step 1	archive config	(Optional) Save the running configuration file to the configuration archive. Note Enter the path archive configuration command before using this command.
Step 2	configure terminal	Enter global configuration mode.
Step 3		Make necessary changes to the running configuration.
Step 4	exit	Return to privileged EXEC mode.
Step 5	configure replace <i>target-url</i> [list] [force] [time seconds] [nolock]	Replace the running configuration file with a saved configuration file. <i>target-url</i> —URL (accessible by the file system) of the saved configuration file that is to replace the running configuration, such as the configuration file created in Step 2 by using the archive config privileged EXEC command. list —Display a list of the command entries applied by the software parser during each pass of the configuration replacement operation. The total number of passes also appears. force — Replace the running configuration file with the specified saved configuration file without prompting you for confirmation. time seconds —Specify the time (in seconds) within which you must enter the configure confirm command to confirm replacement of the running configuration file. If you do not enter the configure confirm command within the specified time limit, the configuration replacement operation is automatically stopped. (In other words, the running configuration file is restored to the configuration that existed before you entered the configure replace command). Note You must first enable the configuration archive before you can use the time seconds command line option. nolock —Disable the locking of the running configuration file that prevents other users from changing the running configuration during a configuration replacement operation.

	Command	Purpose
Step 6	configure confirm	(Optional) Confirm replacement of the running configuration with a saved configuration file. Note Use this command only if the time seconds keyword and argument of the configure replace command are specified.
Step 7	copy running-config startup-config	(Optional) Save your entries in the configuration file.

Working with Software Images

This section describes how to archive (download and upload) software image files, which contain the system software, the Cisco IOS code, and the embedded device manager software.



Note

Instead of using the **copy** privileged EXEC command or the **archive tar** privileged EXEC command, we recommend using the **archive download-sw** and **archive upload-sw** privileged EXEC commands to download and upload software image files.

You can download a switch image file from a TFTP, FTP, or RCP server to upgrade the switch software. If you do not have access to a TFTP server, you can download a software image file directly to your PC or workstation by using a web browser (HTTP) and then by using the device manager or Cisco Network Assistant to upgrade your switch. For information about upgrading your switch by using a TFTP server or a web browser (HTTP), see the release notes.

You can replace the current image with the new one or keep the current image in flash memory after a download.

Beginning with Cisco IOS release 12.2(35)SE, you can use the **archive download-sw /allow-feature-upgrade** privileged EXEC command to allow installation of an image with a different feature set, for example, upgrading from the IP base image to the IP services image. Beginning in this release, you can also use the **boot auto-download-sw** global configuration command to specify a URL to use to get an image for automatic software upgrades. When you enter this command, the master switch uses this URL in case of a version mismatch.

You upload a switch image file to a TFTP, FTP, or RCP server for backup purposes. You can use this uploaded image for future downloads to the same switch or to another of the same type.

The protocol that you use depends on which type of server you are using. The FTP and RCP transport mechanisms provide faster performance and more reliable delivery of data than TFTP. These improvements are possible because FTP and RCP are built on and use the TCP/IP stack, which is connection-oriented.

These sections contain this configuration information:

- [Image Location on the Switch, page B-24](#)
- [tar File Format of Images on a Server or Cisco.com, page B-24](#)
- [Copying Image Files By Using TFTP, page B-25](#)
- [Copying Image Files By Using FTP, page B-28](#)
- [Copying Image Files By Using RCP, page B-33](#)

**Note**

For a list of software images and the supported upgrade paths, see the release notes.

Image Location on the Switch

The Cisco IOS image is stored as a *.bin* file in a directory that shows the version number. A subdirectory contains the files needed for web management. The image is stored on the system board flash memory (flash:).

You can use the **show version** privileged EXEC command to see the software version that is currently running on your switch. In the display, check the line that begins with `System image file is...`. It shows the directory name in flash memory where the image is stored.

You can also use the **dir filesystem:** privileged EXEC command to see the directory names of other software images that might be stored in flash memory. Beginning with Cisco IOS release 12.2(35)SE, the **archive download-sw /directory** privileged EXEC command allows you to specify a directory one time

tar File Format of Images on a Server or Cisco.com

Software images located on a server or downloaded from Cisco.com are provided in a tar file format, which contains these files:

- An *info* file, which serves as a table of contents for the tar file
- One or more subdirectories containing other images and files, such as Cisco IOS images and web management files

This example shows some of the information contained in the info file. [Table B-3](#) provides additional details about this information:

```
system_type:0x00000000:c2960-lanbase-mz.122.25-FX
  image_family:C2960
  stacking_number:1.11
  info_end:

version_suffix:lanbase-122-25.FX
version_directory:c2960-lanbase-mz.122.25-FX
  image_system_type_id:0x00000000
  image_name:c2960-lanbase-mz.122.25-FX.bin
  ios_image_file_size:4413952
  total_image_file_size:4424192
  image_feature: LAYER_2|MIN_DRAM_MEG=64
  image_family:C2960
  stacking_number:1.11
  board_ids:0x00000034 0x00000042 0x00000037 0x00000041 0x0000003c
  info_end:
```

**Note**

Disregard the `stacking_number` field. It does not apply to the switch.

Table B-3 *info File Description*

Field	Description
version_suffix	Specifies the Cisco IOS image version string suffix
version_directory	Specifies the directory where the Cisco IOS image and the HTML subdirectory are installed
image_name	Specifies the name of the Cisco IOS image within the tar file
ios_image_file_size	Specifies the Cisco IOS image size in the tar file, which is an approximate measure of how much flash memory is required to hold just the Cisco IOS image
total_image_file_size	Specifies the size of all the images (the Cisco IOS image and the web management files) in the tar file, which is an approximate measure of how much flash memory is required to hold them
image_feature	Describes the core functionality of the image
image_min_dram	Specifies the minimum amount of DRAM needed to run this image
image_family	Describes the family of products on which the software can be installed

Copying Image Files By Using TFTP

You can download a switch image from a TFTP server or upload the image from the switch to a TFTP server.

You download a switch image file from a server to upgrade the switch software. You can overwrite the current image with the new one or keep the current image after a download.

You upload a switch image file to a server for backup purposes; this uploaded image can be used for future downloads to the same or another switch of the same type.

**Note**

Instead of using the **copy** privileged EXEC command or the **archive tar** privileged EXEC command, we recommend using the **archive download-sw** and **archive upload-sw** privileged EXEC commands to download and upload software image files.

These sections contain this configuration information:

- [Preparing to Download or Upload an Image File By Using TFTP, page B-26](#)
- [Downloading an Image File By Using TFTP, page B-26](#)
- [Uploading an Image File By Using TFTP, page B-28](#)

Preparing to Download or Upload an Image File By Using TFTP

Before you begin downloading or uploading an image file by using TFTP, do these tasks:

- Ensure that the workstation acting as the TFTP server is properly configured. On a Sun workstation, make sure that the `/etc/inetd.conf` file contains this line:

```
tftp dgram udp wait root /usr/etc/in.tftpd in.tftpd -p -s /tftpboot
```

Make sure that the `/etc/services` file contains this line:

```
tftp 69/udp
```

**Note**

You must restart the `inetd` daemon after modifying the `/etc/inetd.conf` and `/etc/services` files. To restart the daemon, either stop the `inetd` process and restart it, or enter a **fastboot** command (on the SunOS 4.x) or a **reboot** command (on Solaris 2.x or SunOS 5.x). For more information on the TFTP daemon, see the documentation for your workstation.

- Ensure that the switch has a route to the TFTP server. The switch and the TFTP server must be in the same subnetwork if you do not have a router to route traffic between subnets. Check connectivity to the TFTP server by using the **ping** command.
- Ensure that the image to be downloaded is in the correct directory on the TFTP server (usually `/tftpboot` on a UNIX workstation).
- For download operations, ensure that the permissions on the file are set correctly. The permission on the file should be world-read.
- Before uploading the image file, you might need to create an empty file on the TFTP server. To create an empty file, enter the **touch filename** command, where *filename* is the name of the file you will use when uploading the image to the server.
- During upload operations, if you are overwriting an existing file (including an empty file, if you had to create one) on the server, ensure that the permissions on the file are set correctly. Permissions on the file should be world-write.

Downloading an Image File By Using TFTP

You can download a new image file and replace the current image or keep the current image.

Beginning in privileged EXEC mode, follow Steps 1 through 3 to download a new image from a TFTP server and overwrite the existing image. To keep the current image, go to Step 3.

	Command	Purpose
Step 1		Copy the image to the appropriate TFTP directory on the workstation. Make sure that the TFTP server is properly configured; see the “Preparing to Download or Upload an Image File By Using TFTP” section on page B-26.
Step 2		Log into the switch through the console port or a Telnet session.
Step 3	archive download-sw /overwrite /reload tftp:[<i>//location</i>]/<i>directory</i>]/<i>image-name.tar</i>	Download the image file from the TFTP server to the switch, and overwrite the current image. <ul style="list-style-type: none"> • The /overwrite option overwrites the software image in flash memory with the downloaded image. • The /reload option reloads the system after downloading the image unless the configuration has been changed and not been saved. • For <i>//location</i>, specify the IP address of the TFTP server. • For <i>/directory/image-name.tar</i>, specify the directory (optional) and the image to download. Directory and image names are case sensitive.
Step 4	archive download-sw /leave-old-sw /reload tftp:[<i>//location</i>]/<i>directory</i>]/<i>image-name.tar</i>	Download the image file from the TFTP server to the switch, and keep the current image. <ul style="list-style-type: none"> • The /leave-old-sw option keeps the old software version after a download. • The /reload option reloads the system after downloading the image unless the configuration has been changed and not been saved. • For <i>//location</i>, specify the IP address of the TFTP server. • For <i>/directory/image-name.tar</i>, specify the directory (optional) and the image to download. Directory and image names are case sensitive.

The download algorithm verifies that the image is appropriate for the switch model and that enough DRAM is present, or it aborts the process and reports an error. If you specify the **/overwrite** option, the download algorithm removes the existing image on the flash device whether or not it is the same as the new one, downloads the new image, and then reloads the software.



Note

If the flash device has sufficient space to hold two images and you want to overwrite one of these images with the same version, you must specify the **/overwrite** option.

If you specify the **/leave-old-sw**, the existing files are not removed. If there is not enough space to install the new image and keep the running image, the download process stops, and an error message is displayed.

The algorithm installs the downloaded image on the system board flash device (flash:). The image is placed into a new directory named with the software version string, and the BOOT environment variable is updated to point to the newly installed image.

If you kept the old image during the download process (you specified the `/leave-old-sw` keyword), you can remove it by entering the `delete /force /recursive filesystem:/file-url` privileged EXEC command. For `filesystem`, use `flash:` for the system board flash device. For `file-url`, enter the directory name of the old image. All the files in the directory and the directory are removed.

**Caution**

For the download and upload algorithms to operate properly, do *not* rename image names.

Uploading an Image File By Using TFTP

You can upload an image from the switch to a TFTP server. You can later download this image to the switch or to another switch of the same type.

Use the upload feature only if the web management pages associated with the embedded device manager have been installed with the existing image.

Beginning in privileged EXEC mode, follow these steps to upload an image to a TFTP server:

	Command	Purpose
Step 1		Make sure the TFTP server is properly configured; see the “Preparing to Download or Upload an Image File By Using TFTP” section on page B-26.
Step 2		Log into the switch through the console port or a Telnet session.
Step 3	<code>archive upload-sw</code> <code>tftp:[[/location]/directory]/image-name.tar</code>	Upload the currently running switch image to the TFTP server. <ul style="list-style-type: none"> For <code>/location</code>, specify the IP address of the TFTP server. For <code>/directory/image-name.tar</code>, specify the directory (optional) and the name of the software image to be uploaded. Directory and image names are case sensitive. The <code>image-name.tar</code> is the name of the software image to be stored on the server.

The `archive upload-sw` privileged EXEC command builds an image file on the server by uploading these files in order: info, the Cisco IOS image, and the web management files. After these files are uploaded, the upload algorithm creates the tar file format.

**Caution**

For the download and upload algorithms to operate properly, do *not* rename image names.

Copying Image Files By Using FTP

You can download a switch image from an FTP server or upload the image from the switch to an FTP server.

You download a switch image file from a server to upgrade the switch software. You can overwrite the current image with the new one or keep the current image after a download.

You upload a switch image file to a server for backup purposes. You can use this uploaded image for future downloads to the switch or another switch of the same type.

**Note**

Instead of using the **copy** privileged EXEC command or the **archive tar** privileged EXEC command, we recommend using the **archive download-sw** and **archive upload-sw** privileged EXEC commands to download and upload software image files.

These sections contain this configuration information:

- [Preparing to Download or Upload an Image File By Using FTP, page B-29](#)
- [Downloading an Image File By Using FTP, page B-30](#)
- [Uploading an Image File By Using FTP, page B-32](#)

Preparing to Download or Upload an Image File By Using FTP

You can copy images files to or from an FTP server.

The FTP protocol requires a client to send a remote username and password on each FTP request to a server. When you copy an image file from the switch to a server by using FTP, the Cisco IOS software sends the first valid username in this list:

- The username specified in the **archive download-sw** or **archive upload-sw** privileged EXEC command if a username is specified.
- The username set by the **ip ftp username** *username* global configuration command if the command is configured.
- Anonymous.

The switch sends the first valid password in this list:

- The password specified in the **archive download-sw** or **archive upload-sw** privileged EXEC command if a password is specified.
- The password set by the **ip ftp password** *password* global configuration command if the command is configured.
- The switch forms a password named *username@switchname.domain*. The variable *username* is the username associated with the current session, *switchname* is the configured hostname, and *domain* is the domain of the switch.

The username and password must be associated with an account on the FTP server. If you are writing to the server, the FTP server must be properly configured to accept the FTP write request from you.

Use the **ip ftp username** and **ip ftp password** commands to specify a username and password for all copies. Include the username in the **archive download-sw** or **archive upload-sw** privileged EXEC command if you want to specify a username only for that operation.

If the server has a directory structure, the image file is written to or copied from the directory associated with the username on the server. For example, if the image file resides in the home directory of a user on the server, specify that user's name as the remote username.

Before you begin downloading or uploading an image file by using FTP, do these tasks:

- Ensure that the switch has a route to the FTP server. The switch and the FTP server must be in the same subnetwork if you do not have a router to route traffic between subnets. Check connectivity to the FTP server by using the **ping** command.

- If you are accessing the switch through the console or a Telnet session and you do not have a valid username, make sure that the current FTP username is the one that you want to use for the FTP download. You can enter the **show users** privileged EXEC command to view the valid username. If you do not want to use this username, create a new FTP username by using the **ip ftp username *username*** global configuration command. This new name will be used during all archive operations. The new username is stored in NVRAM. If you are accessing the switch through a Telnet session and you have a valid username, this username is used, and you do not need to set the FTP username. Include the username in the **archive download-sw** or **archive upload-sw** privileged EXEC command if you want to specify a username for that operation only.
- When you upload an image file to the FTP server, it must be properly configured to accept the write request from the user on the switch.

For more information, see the documentation for your FTP server.

Downloading an Image File By Using FTP

You can download a new image file and overwrite the current image or keep the current image.

Beginning in privileged EXEC mode, follow Steps 1 through 7 to download a new image from an FTP server and overwrite the existing image. To keep the current image, go to Step 7.

	Command	Purpose
Step 1		Verify that the FTP server is properly configured by referring to the “Preparing to Download or Upload an Image File By Using FTP” section on page B-29.
Step 2		Log into the switch through the console port or a Telnet session.
Step 3	configure terminal	Enter global configuration mode. This step is required only if you override the default remote username or password (see Steps 4, 5, and 6).
Step 4	ip ftp username <i>username</i>	(Optional) Change the default remote username.
Step 5	ip ftp password <i>password</i>	(Optional) Change the default password.
Step 6	end	Return to privileged EXEC mode.

	Command	Purpose
Step 7	archive download-sw /overwrite /reload ftp:[[/username[:password]@location]/directory] image-name.tar	<p>Download the image file from the FTP server to the switch, and overwrite the current image.</p> <ul style="list-style-type: none"> • The /overwrite option overwrites the software image in flash memory with the downloaded image. • The /reload option reloads the system after downloading the image unless the configuration has been changed and not been saved. • For //username[:password], specify the username and password; these must be associated with an account on the FTP server. For more information, see the “Preparing to Download or Upload an Image File By Using FTP” section on page B-29. • For @location, specify the IP address of the FTP server. • For directory/image-name.tar, specify the directory (optional) and the image to download. Directory and image names are case sensitive.
Step 8	archive download-sw /leave-old-sw /reload ftp:[[/username[:password]@location]/directory] image-name.tar	<p>Download the image file from the FTP server to the switch, and keep the current image.</p> <ul style="list-style-type: none"> • The /leave-old-sw option keeps the old software version after a download. • The /reload option reloads the system after downloading the image unless the configuration has been changed and not been saved. • For //username[:password], specify the username and password. These must be associated with an account on the FTP server. For more information, see the “Preparing to Download or Upload an Image File By Using FTP” section on page B-29. • For @location, specify the IP address of the FTP server. • For directory/image-name.tar, specify the directory (optional) and the image to download. Directory and image names are case sensitive.

The download algorithm verifies that the image is appropriate for the switch model and that enough DRAM is present, or it aborts the process and reports an error. If you specify the **/overwrite** option, the download algorithm removes the existing image on the flash device, whether or not it is the same as the new one, downloads the new image, and then reloads the software.

**Note**

If the flash device has sufficient space to hold two images and you want to overwrite one of these images with the same version, you must specify the **/overwrite** option.

If you specify the **/leave-old-sw**, the existing files are not removed. If there is not enough space to install the new image and keep the running image, the download process stops, and an error message is displayed.

The algorithm installs the downloaded image onto the system board flash device (flash:). The image is placed into a new directory named with the software version string, and the BOOT environment variable is updated to point to the newly installed image.

If you kept the old image during the download process (you specified the `/leave-old-sw` keyword), you can remove it by entering the `delete /force /recursive filesystem:/file-url` privileged EXEC command. For `filesystem`, use **flash:** for the system board flash device. For `file-url`, enter the directory name of the old software image. All the files in the directory and the directory are removed.

**Caution**

For the download and upload algorithms to operate properly, do *not* rename image names.

Uploading an Image File By Using FTP

You can upload an image from the switch to an FTP server. You can later download this image to the same switch or to another switch of the same type.

Use the upload feature only if the web management pages associated with the embedded device manager have been installed with the existing image.

Beginning in privileged EXEC mode, follow these steps to upload an image to an FTP server:

	Command	Purpose
Step 1		Verify that the FTP server is properly configured by referring to the “Preparing to Download or Upload a Configuration File By Using FTP” section on page B-12.
Step 2		Log into the switch through the console port or a Telnet session.
Step 3	<code>configure terminal</code>	Enter global configuration mode. This step is required only if you override the default remote username or password (see Steps 4, 5, and 6).
Step 4	<code>ip ftp username <i>username</i></code>	(Optional) Change the default remote username.
Step 5	<code>ip ftp password <i>password</i></code>	(Optional) Change the default password.
Step 6	<code>end</code>	Return to privileged EXEC mode.
Step 7	<code>archive upload-sw ftp:[//[<i>username</i>[:<i>password</i>]@]<i>location</i>]/<i>directory</i>]/ <i>image-name.tar</i></code>	Upload the currently running switch image to the FTP server. <ul style="list-style-type: none"> For <code>//username:password</code>, specify the username and password. These must be associated with an account on the FTP server. For more information, see the “Preparing to Download or Upload an Image File By Using FTP” section on page B-29. For <code>@location</code>, specify the IP address of the FTP server. For <code>/directory/image-name.tar</code>, specify the directory (optional) and the name of the software image to be uploaded. Directory and image names are case sensitive. The <code>image-name.tar</code> is the name of the software image to be stored on the server.

The **archive upload-sw** command builds an image file on the server by uploading these files in order: info, the Cisco IOS image, and the web management files. After these files are uploaded, the upload algorithm creates the tar file format.

**Caution**

For the download and upload algorithms to operate properly, do *not* rename image names.

Copying Image Files By Using RCP

You can download a switch image from an RCP server or upload the image from the switch to an RCP server.

You download a switch image file from a server to upgrade the switch software. You can overwrite the current image with the new one or keep the current image after a download.

You upload a switch image file to a server for backup purposes. You can use this uploaded image for future downloads to the same switch or another of the same type.

**Note**

Instead of using the **copy** privileged EXEC command or the **archive tar** privileged EXEC command, we recommend using the **archive download-sw** and **archive upload-sw** privileged EXEC commands to download and upload software image files. .

These sections contain this configuration information:

- [Preparing to Download or Upload an Image File By Using RCP, page B-33](#)
- [Downloading an Image File By Using RCP, page B-35](#)
- [Uploading an Image File By Using RCP, page B-37](#)

Preparing to Download or Upload an Image File By Using RCP

RCP provides another method of downloading and uploading image files between remote hosts and the switch. Unlike TFTP, which uses User Datagram Protocol (UDP), a connectionless protocol, RCP uses TCP, which is connection-oriented.

To use RCP to copy files, the server from or to which you will be copying files must support RCP. The RCP copy commands rely on the rsh server (or daemon) on the remote system. To copy files by using RCP, you do not need to create a server for file distribution as you do with TFTP. You only need to have access to a server that supports the remote shell (rsh). (Most UNIX systems support rsh.) Because you are copying a file from one place to another, you must have read permission on the source file and write permission on the destination file. If the destination file does not exist, RCP creates it for you.

RCP requires a client to send a remote username on each RCP request to a server. When you copy an image from the switch to a server by using RCP, the Cisco IOS software sends the first valid username in this list:

- The username specified in the **archive download-sw** or **archive upload-sw** privileged EXEC command if a username is specified.
- The username set by the **ip rcmd remote-username *username*** global configuration command if the command is entered.

- The remote username associated with the current TTY (terminal) process. For example, if the user is connected to the router through Telnet and was authenticated through the **username** command, the switch software sends the Telnet username as the remote username.
- The switch hostname.

For the RCP copy request to execute successfully, an account must be defined on the network server for the remote username. If the server has a directory structure, the image file is written to or copied from the directory associated with the remote username on the server. For example, if the image file resides in the home directory of a user on the server, specify that user's name as the remote username.

Before you begin downloading or uploading an image file by using RCP, do these tasks:

- Ensure that the workstation acting as the RCP server supports the remote shell (rsh).
- Ensure that the switch has a route to the RCP server. The switch and the server must be in the same subnetwork if you do not have a router to route traffic between subnets. Check connectivity to the RCP server by using the **ping** command.
- If you are accessing the switch through the console or a Telnet session and you do not have a valid username, make sure that the current RCP username is the one that you want to use for the RCP download. You can enter the **show users** privileged EXEC command to view the valid username. If you do not want to use this username, create a new RCP username by using the **ip rcmd remote-username username** global configuration command to be used during all archive operations. The new username is stored in NVRAM. If you are accessing the switch through a Telnet session and you have a valid username, this username is used, and there is no need to set the RCP username. Include the username in the **archive download-sw** or **archive upload-sw** privileged EXEC command if you want to specify a username only for that operation.
- When you upload an image to the RCP to the server, it must be properly configured to accept the RCP write request from the user on the switch. For UNIX systems, you must add an entry to the **.rhosts** file for the remote user on the RCP server.

For example, suppose the switch contains these configuration lines:

```
hostname Switch1
ip rcmd remote-username User0
```

If the switch IP address translates to *Switch1.company.com*, the *.rhosts* file for User0 on the RCP server should contain this line:

```
Switch1.company.com Switch1
```

For more information, see the documentation for your RCP server.

Downloading an Image File By Using RCP

You can download a new image file and replace or keep the current image.

Beginning in privileged EXEC mode, follow Steps 1 through 6 to download a new image from an RCP server and overwrite the existing image. To keep the current image, go to Step 6.

	Command	Purpose
Step 1		Verify that the RCP server is properly configured by referring to the “Preparing to Download or Upload an Image File By Using RCP” section on page B-33.
Step 2		Log into the switch through the console port or a Telnet session.
Step 3	configure terminal	Enter global configuration mode. This step is required only if you override the default remote username (see Steps 4 and 5).
Step 4	ip rcmd remote-username <i>username</i>	(Optional) Specify the remote username.
Step 5	end	Return to privileged EXEC mode.
Step 6	archive download-sw /overwrite /reload rcp: [[[// <i>username@location</i>]/ <i>directory</i>]/ <i>image-name.tar</i>]	Download the image file from the RCP server to the switch, and overwrite the current image. <ul style="list-style-type: none"> The /overwrite option overwrites the software image in flash memory with the downloaded image. The /reload option reloads the system after downloading the image unless the configuration has been changed and not been saved. For <i>//username</i>, specify the username. For the RCP copy request to execute successfully, an account must be defined on the network server for the remote username. For more information, see the “Preparing to Download or Upload an Image File By Using RCP” section on page B-33. For <i>@location</i>, specify the IP address of the RCP server. For <i>/directory/image-name.tar</i>, specify the directory (optional) and the image to download. Directory and image names are case sensitive.

Command	Purpose
Step 7 archive download-sw /leave-old-sw /reload rcp:[[[//[username@]location]/directory]/image-name.tar]	Download the image file from the RCP server to the switch, and keep the current image. <ul style="list-style-type: none"> • The /leave-old-sw option keeps the old software version after a download. • The /reload option reloads the system after downloading the image unless the configuration has been changed and not been saved. • For //username, specify the username. For the RCP copy request to execute, an account must be defined on the network server for the remote username. For more information, see the “Preparing to Download or Upload an Image File By Using RCP” section on page B-33. • For @location, specify the IP address of the RCP server. • For /directory]/image-name.tar, specify the directory (optional) and the image to download. Directory and image names are case sensitive.

The download algorithm verifies that the image is appropriate for the switch model and that enough DRAM is present, or it aborts the process and reports an error. If you specify the **/overwrite** option, the download algorithm removes the existing image on the flash device whether or not it is the same as the new one, downloads the new image, and then reloads the software.

Note

If the flash device has sufficient space to hold two images and you want to overwrite one of these images with the same version, you must specify the **/overwrite** option.

If you specify the **/leave-old-sw**, the existing files are not removed. If there is not enough room to install the new image and keep the running image, the download process stops, and an error message is displayed.

The algorithm installs the downloaded image onto the system board flash device (flash:). The image is placed into a new directory named with the software version string, and the BOOT environment variable is updated to point to the newly installed image.

If you kept the old software during the download process (you specified the **/leave-old-sw** keyword), you can remove it by entering the **delete /force /recursive filesystem:/file-url** privileged EXEC command. For **filesystem**, use **flash:** for the system board flash device. For **file-url**, enter the directory name of the old software image. All the files in the directory and the directory are removed.

Caution

For the download and upload algorithms to operate properly, do *not* rename image names.

Uploading an Image File By Using RCP

You can upload an image from the switch to an RCP server. You can later download this image to the same switch or to another switch of the same type.

The upload feature should be used only if the web management pages associated with the embedded device manager have been installed with the existing image.

Beginning in privileged EXEC mode, follow these steps to upload an image to an RCP server:

	Command	Purpose
Step 1		Verify that the RCP server is properly configured by referring to the “Preparing to Download or Upload an Image File By Using RCP” section on page B-33.
Step 2		Log into the switch through the console port or a Telnet session.
Step 3	configure terminal	Enter global configuration mode. This step is required only if you override the default remote username (see Steps 4 and 5).
Step 4	ip rcmd remote-username <i>username</i>	(Optional) Specify the remote username.
Step 5	end	Return to privileged EXEC mode.
Step 6	archive upload-sw rcp: [[[// <i>username@</i>] <i>location</i>]/ <i>directory</i>]/ <i>image-name.tar</i>]	Upload the currently running switch image to the RCP server. <ul style="list-style-type: none"> For <i>//username</i>, specify the username; for the RCP copy request to execute, an account must be defined on the network server for the remote username. For more information, see the “Preparing to Download or Upload an Image File By Using RCP” section on page B-33. For <i>@location</i>, specify the IP address of the RCP server. For <i>/directory/image-name.tar</i>, specify the directory (optional) and the name of the software image to be uploaded. Directory and image names are case sensitive. The <i>image-name.tar</i> is the name of software image to be stored on the server.

The **archive upload-sw** privileged EXEC command builds an image file on the server by uploading these files in order: info, the Cisco IOS image, and the web management files. After these files are uploaded, the upload algorithm creates the tar file format.



Caution

For the download and upload algorithms to operate properly, do *not* rename image names.



APPENDIX **C**

Recommendations for Upgrading a Catalyst 2950 Switch to a Catalyst 2960 Switch

This appendix describes the configuration compatibility issues and the feature behavior differences that you might encounter when you upgrade a Catalyst 2950 switch to a Catalyst 2960 switch.

This appendix consists of these sections:

- [Configuration Compatibility Issues, page C-1](#)
- [Feature Behavior Incompatibilities, page C-5](#)

Configuration Compatibility Issues

The configuration commands between the two switch platforms differ for these reasons:

- The Catalyst 2950 switch runs Cisco IOS 12.1EA software, and the Catalyst 2960 switch runs Cisco IOS 12.2SE software.
- The switch families have different hardware.

If you use a Catalyst 2950 switch command, it might not be supported on the Catalyst 2960 switch. The Catalyst 2960 switch software handles the incompatible commands in these ways:

- They are accepted and translated. A message appears.
- They are rejected. A message appears.

In most cases, configuration files are loaded without rejections. [Table C-1](#) lists the Catalyst 2950 exceptions. The features are listed in alphabetic order, with Catalyst 2950 commands and explanations, and the resulting action on the Catalyst 2960 switch.

Table C-1 Catalyst 2950 and 2960 Switch Configuration Incompatibilities

Feature	Catalyst 2950 Switch Command and Explanation	Result on the Catalyst 2960 Switch
AAA	<p>These global configuration commands are in Cisco IOS 12.1EA:</p> <p>aaa preauth</p> <p>aaa processes 1-64</p> <p>aaa route download 1-1440</p>	<p>When Cisco IOS 12.2E was restructured, these commands were intentionally removed and are not supported in Cisco IOS 12.2SE.</p> <p>The Catalyst 2960 switch rejects these commands, and this message appears:</p> <pre>Switch(config)# aaa processes 10 ^ %Invalid input detected at '^' marker.</pre>
Clustering	<p>The Catalyst 2950 switch supports only one management VLAN. You can use this global configuration command to change it:</p> <p>cluster management-vlan <i>vlan-id</i></p> <p>This command communicates the management VLAN when the switch is configured for clustering.</p>	<p>With the Catalyst 2960 switch, you can connect to candidate and cluster member switches through any VLAN in common with the cluster command switch.</p> <p>The Catalyst 2960 switch rejects the command, and this message appears:</p> <pre>Switch(config)# cluster management-vlan 2 ^ %Invalid input detected at '^' marker.</pre>
DHCP snooping	<p>A Catalyst 2950 switch DHCP snooping feature limits the number of DHCP packets per second that an interface can receive. You use this interface configuration command to configure it:</p> <p>ip dhcp snooping limit rate <i>rate</i></p> <p>The range is 1 to 4294967294, and by default, the rate limit is not configured.</p>	<p>In Cisco IOS 12.2SE, the range was changed to 1 to 2048 messages per second.</p> <p>The Catalyst 2960 switch accepts any range value. It changes the maximum value to 2048 (if it is more than 2048), and this message appears:</p> <pre>%Invalid input detected at '^' marker.%</pre>
Flow control	<p>The Catalyst 2950 switch supports pause frames on Gigabit Ethernet interfaces. You use this interface configuration command to configure it:</p> <p>flowcontrol send {desired off on}</p>	<p>The Catalyst 2960 switch accepts received pause frames but cannot send them. The flowcontrol send command is not supported on the Catalyst 2960 switch.</p> <p>The Catalyst 2960 switch rejects the command, and this message appears:</p> <pre>Switch(config-if)# flowcontrol send desired ^ %Invalid input detected at '^' marker.</pre> <p>You can configure QoS to restrict data traffic without affecting the control traffic. With flow control, all traffic is stopped. For more information, see Chapter 28, “Configuring QoS.”</p>

Table C-1 Catalyst 2950 and 2960 Switch Configuration Incompatibilities (continued)

Feature	Catalyst 2950 Switch Command and Explanation	Result on the Catalyst 2960 Switch
IEEE 802.1x	<p>In Cisco IOS 12.1EA, the Catalyst 2950 switch ranges for the IEEE 802.1x server-timeout, supp-timeout, and tx-period are 1 to 65535. You use these interface configuration commands to configure them:</p> <pre>dot1x timeout server-timeout seconds dot1x timeout supp-timeout seconds dot1x timeout tx-period seconds</pre>	<p>In Cisco IOS 12.2SE, the IEEE 802.1x server-timeout and supp-timeout ranges are 30 to 65535. The tx-period range is 15 to 65535.</p> <p>For server-timeout, the Catalyst 2960 switch accepts 1 to 29 as a valid lower value and changes the value to 30.</p> <p>For supp-timeout, the Catalyst 2960 switch accepts 1 to 29 as a valid lower value and changes the value to 30.</p> <p>For tx-timeout, the Catalyst 2960 switch accepts 1 to 14 as a valid lower value and changes the value to 15.</p> <p>For all three commands, this message appears:</p> <pre>%Invalid input detected at '^' marker.</pre>
IGMP ¹ snooping	<p>The Catalyst 2950 switch implements IGMP snooping based on MAC addresses. You use this global configuration command to configure static groups:</p> <pre>ip igmp snooping vlan vlan-id static mac-address interface interface-id</pre> <p>These Catalyst 2950 switch global configuration commands were implemented to address hardware limitations:</p> <pre>ip igmp snooping source-only-learning [age-timer value] no ip igmp snooping mrouter learn pim v2</pre>	<p>The Catalyst 2960 switch implements IGMP snooping based on IP addresses and uses other advanced hardware. It rejects the Catalyst 2950 IGMP snooping commands, and these messages appear:</p> <pre>Switch(config)# ip igmp snooping vlan 1 static 0002.4b28.c482 interface gigabitethernet0/1 ^ %Invalid input detected at '^' marker. Switch(config)# ip igmp snooping source-only-learning ^ %Invalid input detected at '^' marker. Switch(config)# no ip igmp snooping mrouter learn pim v2 ^ %Invalid input detected at '^' marker.</pre>
Interface MAC address	<p>On the Catalyst 2950 switch, you can set the MAC address for both physical and switch virtual interfaces (SVIs) by using this interface configuration command:</p> <pre>mac-address mac-address</pre>	<p>On the Catalyst 2960 switch, you cannot set the MAC address for physical and SVIs.</p> <p>The switch rejects the command, and this message appears:</p> <pre>Switch(config-if)# mac-address 0100.0ccc.cccc ^ %Invalid input detected at '^' marker.</pre>

Table C-1 Catalyst 2950 and 2960 Switch Configuration Incompatibilities (continued)

Feature	Catalyst 2950 Switch Command and Explanation	Result on the Catalyst 2960 Switch
QoS ²	<p>There is limited QoS configuration compatibility between the Catalyst 2950 switch and the Catalyst 2960 switch.</p> <p>We recommend that you enable automatic QoS (auto-QoS) on the Catalyst 2950 switch by using the auto qos voip {cisco-phone cisco-softphone trust} interface configuration command.</p> <p>If you have a custom QoS configuration on the Catalyst 2950 switch, we recommend that you use auto-QoS for transition to the Catalyst 2960 switch.</p> <p>Note If auto-QoS does not provide the configuration required for your network, we recommend that you remove the QoS configuration on the Catalyst 2950 switch and create a new configuration on the Catalyst 2960 switch.</p>	<p>The Catalyst 2960 switch accepts the auto qos command and generates QoS commands that are appropriate for the Catalyst 2960 switch. The policer granularity is adjusted to 1 Mbps.</p> <p>For more information about the generated commands, see the auto qos voip command in the command reference for this release.</p>
	<p>Auto-QoS is not enabled on the Catalyst 2950 switch, but other QoS commands are configured.</p>	<p>These Catalyst 2950 switch commands might fail on the Catalyst 2960 switch:</p> <p>mls qos map dscp-cos global configuration command</p> <p>wrr-queue cos-map global configuration command</p> <p>wrr-queue cos-bandwidth global configuration command</p> <p>mls qos trust cos pass-through dscp interface configuration command</p> <p>police policy-map class configuration command</p> <p>The switch might display this message:</p> <pre> ^ %Invalid input detected at '^' marker.</pre>

Table C-1 Catalyst 2950 and 2960 Switch Configuration Incompatibilities (continued)

Feature	Catalyst 2950 Switch Command and Explanation	Result on the Catalyst 2960 Switch
RSPAN ³	You have to specify one port as the reflector port with this global configuration command: monitor session session_number destination remote vlan vlan-id reflector-port interface-id	Because of advanced hardware in the Catalyst 2960 switch, you do not need to configure a reflector port. The Catalyst 2960 switch accepts the monitor session session-number destination remote vlan vlan-id reflector-port interface-id command, and this message appears: Note: Reflector port configuration is not required on this platform, ignoring the reflector port configuration
STP	The Catalyst 2950 switch supports cross-stack UplinkFast on GBIC ⁴ interfaces. You enable the stack port with this interface configuration command: spanning-tree stack-port	The Catalyst 2960 switch does not support GBIC interfaces. It rejects the command, and this message appears: Switch(config-if)# spanning-tree stack-port ^ %Invalid input detected at '^' marker.

1. IGMP = Internet Group Management Protocol
2. QoS = quality of service
3. RSPAN = Remote Switched Port Analyzer
4. GBIC = Gigabit Interface Converter

Feature Behavior Incompatibilities

Some features behave differently on the Catalyst 2950 and Catalyst 2960 switches, and some features are not supported on the Catalyst 2960 switch:

- Access control lists (ACLs)

Even though the command syntax is the same on the Catalyst 2960 switch and on the Catalyst 2950 switch, the semantics of the IP and the MAC ACL between the two platforms differ. For example, you can apply MAC ACLs for IP packets on the Catalyst 2950 switch, but on the Catalyst 2960 switch:

- You cannot apply MAC ACLs to IP packets.
- You cannot apply any ACLs for IPv6 frames.
- With MAC ACLs, an EtherType of Appletalk is not supported.

- QoS

The Catalyst 2960 switch uses different port hardware than the Catalyst 2950 switch, and more QoS features are offered on the Catalyst 2960 switch. For example, the Catalyst 2950 switch supports WRR scheduling, whereas the Catalyst 2960 switch supports SRR scheduling. Also, you must enable QoS globally on the Catalyst 2960 switch, whereas QoS is enabled by default on the Catalyst 2950 switch. For more information, see [Chapter 28, “Configuring QoS.”](#)

- RSPAN

The Catalyst 2950 switch uses an extra port, called the reflector port, for its RSPAN implementation. This is not necessary in the Catalyst 2960 switch RSPAN implementation. The Catalyst 2960 switch also supports VLANs as SPAN sources and can forward received packets on SPAN destination ports.

- Multicast

The multicast forwarding decisions on the Catalyst 2960 switch are based on IP addresses. Some Catalyst 2950 switch workarounds to address platform limitations (such as the **ip igmp snooping source-only-learning** global configuration command) are not required on the Catalyst 2960 switch.



APPENDIX **D**

Unsupported Commands in Cisco IOS Release 12.2(40)SE

This appendix lists some of the command-line interface (CLI) commands that appear when you enter the question mark (?) at the Catalyst 2960 switch prompt but are not supported in this release, either because they are not tested or because of Catalyst 2960 switch hardware limitations. This is not a complete list. The unsupported commands are listed by software feature and command mode.

Access Control Lists

Unsupported Privileged EXEC Commands

```
access-enable [host] [timeout minutes]  
access-template [access-list-number | name] [dynamic-name] [source] [destination] [timeout minutes]  
clear access-template [access-list-number | name] [dynamic-name] [source] [destination].  
show access-lists rate-limit [destination]  
show accounting  
show ip accounting [checkpoint] [output-packets | access violations]  
show ip cache [prefix-mask] [type number]
```

Unsupported Global Configuration Commands

```
access-list rate-limit acl-index {precedence | mask prec-mask}  
access-list dynamic extended
```

Unsupported Route-Map Configuration Commands

```
match ip address prefix-list prefix-list-name [prefix-list-name...]
```

Boot Loader Commands

Unsupported User EXEC Commands

Unsupported Global Configuration Commands

boot buffersize

Embedded Event Manager

Unsupported Privileged EXEC Commands

event manager update user policy [*policy-filename* | group [*group name expression*]] | repository [*url location*]

Parameters are not supported for this command:

event manager run [*policy name*] |<parameter1>|... <parameter15>|

Unsupported Global Configuration Commands

no event manager directory user repository [*url location*]

event manager applet [*applet-name*] maxrun

Unsupported Commands in Applet Configuration Mode

no event interface name [*interface-name*] parameter [*counter-name*] entry-val [*entry counter value*] entry-op {*gt|ge|eq|ne|lt|le*} [entry-type {**increment** | **rate** | **value**] [exit-val [*exit value*] exit-op {*gt|ge|eq|ne|lt|le*} exit-type { **increment** | **rate** | **value**}] [**average-factor** <**average-factor-value**>]

no trigger

tag

Debug Commands

Unsupported Privileged EXEC Commands

debug platform cli-redirection main

debug platform configuration

IGMP Snooping Commands

Unsupported Global Configuration Commands

```
ip igmp snooping tcn
```

Interface Commands

Unsupported Privileged EXEC Commands

```
show interfaces [interface-id | vlan vlan-id] [crb | fair-queue | irb | mac-accounting | precedence | irb  
| random-detect | rate-limit | shape]
```

Unsupported Global Configuration Commands

```
interface tunnel
```

Unsupported Interface Configuration Commands

```
transmit-interface type number  
ip igmp helper-address ip-address
```

MAC Address Commands

Unsupported Privileged EXEC Commands

```
show mac-address-table  
show mac-address-table address  
show mac-address-table aging-time  
show mac-address-table count  
show mac-address-table dynamic  
show mac-address-table interface  
show mac-address-table multicast  
show mac-address-table notification  
show mac-address-table static
```

`show mac-address-table vlan`

`show mac address-table multicast`



Note Use the `show ip igmp snooping groups` privileged EXEC command to display Layer 2 multicast address-table entries for a VLAN.

Unsupported Global Configuration Commands

`mac-address-table aging-time`

`mac-address-table notification`

`mac-address-table static`

Miscellaneous

Unsupported Privileged EXEC Commands

`file verify auto`

`show cable-diagnostics prbs`

`test cable-diagnostics prbs`

Unsupported Global Configuration Commands

`errdisable recovery cause unicast flood`

`l2protocol-tunnel global drop-threshold`

`service compress-config`

`stack-mac persistent timer`

Network Address Translation (NAT) Commands

Unsupported Privileged EXEC Commands

`show ip nat statistics`

`show ip nat translations`

QoS

Unsupported Global Configuration Command

priority-list

Unsupported Interface Configuration Commands

priority-group

rate-limit

Unsupported Policy-Map Configuration Command

class class-default where **class-default** is the *class-map-name*.

RADIUS

Unsupported Global Configuration Commands

aaa nas port extended

aaa authentication *feature* default enable

aaa authentication *feature* default line

aaa nas port extended

radius-server attribute nas-port

radius-server configure

radius-server extended-portnames

SNMP

Unsupported Global Configuration Commands

snmp-server enable informs

snmp-server ifindex persist

Spanning Tree

Unsupported Global Configuration Command

`spanning-tree pathcost method {long | short}`

Unsupported Interface Configuration Command

`spanning-tree stack-port`

VLAN

Unsupported Global Configuration Command

`vlan internal allocation policy {ascending | descending}`

Unsupported vlan-config Command

`private-vlan`

Unsupported User EXEC Commands

`show running-config vlan`

`show vlan ifindex`

`show vlan private-vlan`

VTP

Unsupported Privileged EXEC Commands

`vtp {password password | pruning | version number}`

**Note**

This command has been replaced by the **vtp** global configuration command.



INDEX

A

- abbreviating commands [2-4](#)
- AC (command switch) [5-9](#)
- access-denied response, VMPS [12-24](#)
- accessing
 - clusters, switch [5-12](#)
 - command switches [5-10](#)
 - member switches [5-12](#)
 - switch clusters [5-12](#)
- access ports
 - in switch clusters [5-8](#)
- access ports, defined [10-2](#)
- accounting
 - with 802.1x [9-29](#)
 - with IEEE 802.1x [9-8](#)
 - with RADIUS [8-28](#)
 - with TACACS+ [8-11, 8-17](#)
- ACEs
 - and QoS [28-7](#)
- ACLs
 - applying
 - to QoS [28-7](#)
 - classifying traffic for QoS [28-41](#)
 - examples of [28-41](#)
 - extended IP, configuring for QoS classification [28-42](#)
 - IP
 - fragments and QoS guidelines [28-32](#)
 - MAC extended [28-43](#)
 - number per QoS class map [28-32](#)
 - QoS [28-7, 28-41](#)
 - standard IP, configuring for QoS classification [28-41](#)
 - support for [1-8](#)
- active traffic monitoring, IP SLAs [27-1](#)
- address aliasing [18-2](#)
- addresses
 - displaying the MAC address table [6-26](#)
 - dynamic
 - accelerated aging [15-8](#)
 - changing the aging time [6-21](#)
 - default aging [15-8](#)
 - defined [6-19](#)
 - learning [6-20](#)
 - removing [6-22](#)
 - MAC, discovering [6-26](#)
 - multicast, STP address management [15-8](#)
 - static
 - adding and removing [6-24](#)
 - defined [6-19](#)
- address resolution [6-26](#)
- Address Resolution Protocol
 - See ARP
- advertisements
 - CDP [20-1](#)
 - LLDP [21-2](#)
 - VTP [12-16, 13-3](#)
- aggregatable global unicast addresses [29-3](#)
- aggregated ports
 - See EtherChannel
- aggregate policers [28-49](#)
- aggregate policing [1-9](#)
- aging, accelerating [15-8](#)

- aging time
 - accelerated
 - for MSTP [16-23](#)
 - for STP [15-8, 15-21](#)
 - MAC address table [6-21](#)
 - maximum
 - for MSTP [16-23, 16-24](#)
 - for STP [15-21, 15-22](#)
 - alarms, RMON [24-3](#)
 - allowed-VLAN list [12-18](#)
 - ARP
 - defined [1-4, 6-26](#)
 - table
 - address resolution [6-26](#)
 - managing [6-26](#)
 - attributes, RADIUS
 - vendor-proprietary [8-31](#)
 - vendor-specific [8-29](#)
 - audience [xxix](#)
 - authentication
 - local mode with AAA [8-32](#)
 - NTP associations [6-4](#)
 - RADIUS
 - key [8-21](#)
 - login [8-23](#)
 - TACACS+
 - defined [8-11](#)
 - key [8-13](#)
 - login [8-14](#)

See also port-based authentication
 - authentication failed VLAN
 - See restricted VLAN
 - authoritative time source, described [6-2](#)
 - authorization
 - with RADIUS [8-27](#)
 - with TACACS+ [8-11, 8-16](#)
 - authorized ports with IEEE 802.1x [9-7](#)
 - autoconfiguration [3-3](#)
 - automatic discovery
 - considerations
 - beyond a noncandidate device [5-7](#)
 - brand new switches [5-8](#)
 - connectivity [5-4](#)
 - different VLANs [5-6](#)
 - management VLANs [5-7](#)
 - non-CDP-capable devices [5-6](#)
 - noncluster-capable devices [5-6](#)
 - in switch clusters [5-4](#)
 - See also CDP
 - automatic QoS
 - See QoS
 - automatic recovery, clusters [5-9](#)
 - See also HSRP
 - auto-MDIX
 - configuring [10-15](#)
 - described [10-15](#)
 - autonegotiation
 - duplex mode [1-2](#)
 - interface configuration guidelines [10-12](#)
 - mismatches [32-11](#)
 - autosensing, port speed [1-2](#)
 - auxiliary VLAN
 - See voice VLAN
 - availability, features [1-6](#)
-
- B**
- BackboneFast
 - described [17-5](#)
 - disabling [17-14](#)
 - enabling [17-13](#)
 - support for [1-6](#)
 - banners
 - configuring
 - login [6-19](#)
 - message-of-the-day login [6-18](#)

banners (continued)

- default configuration [6-17](#)

- when displayed [6-17](#)

- blocking packets [19-7](#)

booting

- boot loader, function of [3-2](#)

- boot process [3-1](#)

- manually [3-13](#)

- specific image [3-14](#)

boot loader

- accessing [3-14](#)

- described [3-2](#)

- environment variables [3-14](#)

- prompt [3-14](#)

- trap-door mechanism [3-2](#)

BPDU

- error-disabled state [17-2](#)

- filtering [17-3](#)

- RSTP format [16-12](#)

BPDU filtering

- described [17-3](#)

- disabling [17-12](#)

- enabling [17-12](#)

- support for [1-6](#)

BPDU guard

- described [17-2](#)

- disabling [17-12](#)

- enabling [17-11](#)

- support for [1-6](#)

bridge protocol data unit

- See BPDU

- broadcast storm-control command [19-4](#)

- broadcast storms [19-1](#)

C

- cables, monitoring for unidirectional links [22-1](#)

candidate switch

- automatic discovery [5-4](#)

- defined [5-3](#)

- requirements [5-3](#)

- See also command switch, cluster standby group, and member switch

CA trustpoint

- configuring [8-40](#)

- defined [8-38](#)

- caution, described [xxx](#)

CDP

- and trusted boundary [28-37](#)

- automatic discovery in switch clusters [5-4](#)

- configuring [20-2](#)

- default configuration [20-2](#)

- defined with LLDP [21-1](#)

- described [20-1](#)

- disabling for routing device [20-3 to 20-4](#)

- enabling and disabling

- on an interface [20-4](#)

- on a switch [20-3](#)

- monitoring [20-4](#)

- overview [20-1](#)

- support for [1-4](#)

- transmission timer and holdtime, setting [20-2](#)

- updates [20-2](#)

CGMP

- as IGMP snooping learning method [18-8](#)

- joining multicast group [18-3](#)

- CipherSuites [8-39](#)

- Cisco 7960 IP Phone [14-1](#)

- Cisco Discovery Protocol

- See CDP

- Cisco IOS File System

- See IFS

- Cisco IOS IP Service Level Agreements (SLAs) responder [1-3](#)
- Cisco IOS IP SLAs [27-1](#)
- Cisco Network Assistant
 - See Network Assistant
- CiscoWorks 2000 [1-4, 26-4](#)
- CIST regional root
 - See MSTP
- CIST root
 - See MSTP
- civic location [21-3](#)
- class maps for QoS
 - configuring [28-44](#)
 - described [28-7](#)
 - displaying [28-69](#)
- class of service
 - See CoS
- clearing interfaces [10-19](#)
- CLI
 - abbreviating commands [2-4](#)
 - command modes [2-1](#)
 - configuration logging [2-5](#)
 - described [1-4](#)
 - editing features
 - enabling and disabling [2-7](#)
 - keystroke editing [2-7](#)
 - wrapped lines [2-9](#)
 - error messages [2-5](#)
 - filtering command output [2-10](#)
 - getting help [2-3](#)
 - history
 - changing the buffer size [2-6](#)
 - described [2-6](#)
 - disabling [2-7](#)
 - recalling commands [2-6](#)
 - managing clusters [5-14](#)
 - no and default forms of commands [2-4](#)
- client mode, VTP [13-3](#)
- clock
 - See system clock
- cluster requirements [xxxix](#)
- clusters, switch
 - accessing [5-12](#)
 - automatic discovery [5-4](#)
 - automatic recovery [5-9](#)
 - benefits [1-1](#)
 - compatibility [5-4](#)
 - described [5-1](#)
 - LRE profile considerations [5-14](#)
 - managing
 - through CLI [5-14](#)
 - through SNMP [5-15](#)
 - planning [5-4](#)
 - planning considerations
 - automatic discovery [5-4](#)
 - automatic recovery [5-9](#)
 - CLI [5-14](#)
 - host names [5-12](#)
 - IP addresses [5-12](#)
 - LRE profiles [5-14](#)
 - passwords [5-13](#)
 - RADIUS [5-14](#)
 - SNMP [5-13, 5-15](#)
 - TACACS+ [5-14](#)
- See also candidate switch, command switch, cluster standby group, member switch, and standby command switch
- cluster standby group
 - automatic recovery [5-11](#)
 - considerations [5-10](#)
 - defined [5-2](#)
 - requirements [5-3](#)
 - virtual IP address [5-10](#)
 - See also HSRP

CNS 1-4

Configuration Engine

configID, deviceID, hostname **4-3**configuration service **4-2**described **4-1**event service **4-3**

embedded agents

described **4-5**enabling automated configuration **4-6**enabling configuration agent **4-9**enabling event agent **4-8**management functions **1-4**

Coarse Wave Division Multiplexer

See CWDM SFPs

command-line interface

See CLI

command modes **2-1**

commands

abbreviating **2-4**no and default **2-4**commands, setting privilege levels **8-8**

command switch

accessing **5-10**active (AC) **5-9**configuration conflicts **32-11**defined **5-2**passive (PC) **5-9**password privilege levels **5-15**priority **5-9**

recovery

from command-switch failure **5-9, 32-7**from lost member connectivity **32-11**redundant **5-9**

replacing

with another switch **32-10**with cluster member **32-8**requirements **5-3****command switch (continued)**standby (SC) **5-9**

See also candidate switch, cluster standby group, member switch, and standby command switch

community strings

configuring **5-13, 26-8**for cluster switches **26-4**in clusters **5-13**overview **26-4**SNMP **5-13**compatibility, feature **19-11**config.text **3-12**configurable leave timer, IGMP **18-5**

configuration, initial

defaults **1-10**Express Setup **1-2**

See also getting started guide and hardware installation guide

configuration changes, logging **25-10**configuration conflicts, recovering from lost member connectivity **32-11**configuration examples, network **1-12**

configuration files

archiving **B-20**clearing the startup configuration **B-19**creating using a text editor **B-10**default name **3-12**deleting a stored configuration **B-19**described **B-8**

downloading

automatically **3-12**preparing **B-10, B-13, B-16**reasons for **B-8**using FTP **B-13**using RCP **B-17**using TFTP **B-11**guidelines for creating and using **B-9**guidelines for replacing and rolling back **B-5**invalid combinations when copying **B-5**limiting TFTP server access **26-16**

configuration files (continued)

- obtaining with DHCP [3-7](#)
- password recovery disable considerations [8-5](#)
- replacing a running configuration [B-19, B-20](#)
- rolling back a running configuration [B-19, B-20](#)
- specifying the filename [3-12](#)
- system contact and location information [26-15](#)
- types and location [B-10](#)
- uploading
 - preparing [B-10, B-13, B-16](#)
 - reasons for [B-9](#)
 - using FTP [B-14](#)
 - using RCP [B-18](#)
 - using TFTP [B-12](#)
- configuration logger [25-10](#)
- configuration logging [2-5](#)
- configuration replacement [B-19](#)
- configuration rollback [B-19, B-20](#)
- configuration settings, saving [3-10](#)
- configure terminal command [10-5](#)
- config-vlan mode [2-2, 12-6](#)
- conflicts, configuration [32-11](#)
- connections, secure remote [8-33](#)
- connectivity problems [32-12, 32-14, 32-15](#)
- consistency checks in VTP Version 2 [13-4](#)
- console port, connecting to [2-10](#)
- control protocol, IP SLAs [27-3](#)
- conventions
 - command [xxx](#)
 - for examples [xxx](#)
 - publication [xxx](#)
 - text [xxx](#)
- corrupted software, recovery steps with Xmodem [32-2](#)
- CoS
 - in Layer 2 frames [28-2](#)
 - override priority [14-6](#)
 - trust priority [14-6](#)
- CoS input queue threshold map for QoS [28-15](#)
- CoS output queue threshold map for QoS [28-18](#)

- CoS-to-DSCP map for QoS [28-52](#)
- counters, clearing interface [10-19](#)
- crashinfo file [32-21](#)
- critical authentication, IEEE 802.1x [9-33](#)
- cryptographic software image
 - SSH [8-33](#)
 - SSL [8-37](#)
- CWDM SFPs [1-17](#)

D

- daylight saving time [6-13](#)
- debugging
 - enabling all system diagnostics [32-19](#)
 - enabling for a specific feature [32-18](#)
 - redirecting error message output [32-19](#)
 - using commands [32-18](#)
- default commands [2-4](#)
- default configuration
 - 802.1x [9-19](#)
 - auto-QoS [28-20](#)
 - banners [6-17](#)
 - booting [3-12](#)
 - CDP [20-2](#)
 - DNS [6-16](#)
 - EtherChannel [31-9](#)
 - Ethernet interfaces [10-9](#)
 - IGMP filtering [18-24](#)
 - IGMP snooping [18-6, 30-5, 30-6](#)
 - IGMP throttling [18-24](#)
 - initial switch information [3-3](#)
 - IP SLAs [27-5](#)
 - IPv6 [29-8](#)
 - Layer 2 interfaces [10-9](#)
 - LLDP [21-3](#)
 - MAC address table [6-21](#)
 - MSTP [16-14](#)
 - MVR [18-19](#)
 - NTP [6-4](#)

default configuration (continued)

- optional spanning-tree configuration [17-9](#)
- password and privilege level [8-2](#)
- RADIUS [8-20](#)
- RMON [24-3](#)
- RSPAN [23-9](#)
- SDM template [7-2](#)
- SNMP [26-7](#)
- SPAN [23-9](#)
- SSL [8-40](#)
- standard QoS [28-30](#)
- STP [15-11](#)
- system message logging [25-3](#)
- system name and prompt [6-15](#)
- TACACS+ [8-13](#)
- UDLD [22-4](#)
- VLAN, Layer 2 Ethernet interfaces [12-16](#)
- VLANs [12-7](#)
- VMPS [12-25](#)
- voice VLAN [14-3](#)
- VTP [13-6](#)
- default gateway [3-10](#)
- deleting VLANs [12-9](#)
- denial-of-service attack [19-1](#)
- description command [10-16](#)
- designing your network, examples [1-12](#)
- destination-IP address-based forwarding, EtherChannel [31-7](#)
- destination-MAC address forwarding, EtherChannel [31-6](#)
- detecting indirect link failures, STP [17-5](#)
- device [B-23](#)
- device discovery protocol [20-1, 21-1](#)
- device manager
 - benefits [1-1](#)
 - described [1-2, 1-3](#)
 - in-band management [1-5](#)
 - requirements [xxx](#)
 - upgrading a switch [B-23](#)

DHCP-based autoconfiguration

- client request message exchange [3-4](#)
- configuring
 - client side [3-3](#)
 - DNS [3-6](#)
 - relay device [3-6](#)
 - server side [3-5](#)
 - TFTP server [3-6](#)
- example [3-8](#)
- lease options
 - for IP address information [3-5](#)
 - for receiving the configuration file [3-5](#)
- overview [3-3](#)
- relationship to BOOTP [3-3](#)
- relay support [1-4](#)
- support for [1-4](#)
- Differentiated Services architecture, QoS [28-2](#)
- Differentiated Services Code Point [28-2](#)
- directed unicast requests [1-4](#)
- directories
 - changing [B-4](#)
 - creating and removing [B-4](#)
 - displaying the working [B-4](#)
- discovery, clusters
 - See automatic discovery
- DNS
 - and DHCP-based autoconfiguration [3-6](#)
 - default configuration [6-16](#)
 - displaying the configuration [6-17](#)
 - in IPv6 [29-4](#)
 - overview [6-15](#)
 - setting up [6-16](#)
 - support for [1-4](#)
- documentation, related [xxx](#)
- document conventions [xxx](#)
- domain names
 - DNS [6-15](#)
 - VTP [13-8](#)

Domain Name System

See DNS

downloading

configuration files

preparing [B-10, B-13, B-16](#)

reasons for [B-8](#)

using FTP [B-13](#)

using RCP [B-17](#)

using TFTP [B-11](#)

image files

deleting old image [B-28](#)

preparing [B-26, B-29, B-33](#)

reasons for [B-23](#)

using CMS [1-2](#)

using FTP [B-30](#)

using HTTP [1-2, B-23](#)

using RCP [B-35](#)

using TFTP [B-27](#)

using the device manager or Network Assistant [B-23](#)

DSCP [1-9, 28-2](#)

DSCP input queue threshold map for QoS [28-15](#)

DSCP output queue threshold map for QoS [28-18](#)

DSCP-to-CoS map for QoS [28-55](#)

DSCP-to-DSCP-mutation map for QoS [28-56](#)

DSCP transparency [28-38](#)

DTP [1-7, 12-14](#)

Dual IPv4-and-IPv6 SDM Templates [29-7](#)

dual IPv4 and IPv6 templates [29-1, 29-6](#)

dual protocol stacks

IPv4 and IPv6 [29-6](#)

SDM templates supporting [29-6](#)

dual-purpose uplinks

defined [10-4](#)

LEDs [10-4](#)

link selection [10-4](#)

setting the type [10-10](#)

dynamic access ports

characteristics [12-3](#)

configuring [12-26](#)

defined [10-3](#)

dynamic addresses

See addresses

dynamic auto trunking mode [12-15](#)

dynamic desirable trunking mode [12-15](#)

Dynamic Host Configuration Protocol

See DHCP-based autoconfiguration

dynamic port VLAN membership

described [12-24](#)

reconfirming [12-27](#)

troubleshooting [12-29](#)

types of connections [12-26](#)

Dynamic Trunking Protocol

See DTP

E

editing features

enabling and disabling [2-7](#)

keystrokes used [2-7](#)

wrapped lines [2-9](#)

ELIN location [21-3](#)

enable password [8-3](#)

enable secret password [8-3](#)

encryption, CipherSuite [8-39](#)

encryption for passwords [8-3](#)

environment variables, function of [3-15](#)

error-disabled state, BPDU [17-2](#)

error messages during command entry [2-5](#)

EtherChannel

automatic creation of [31-4, 31-5](#)

channel groups

binding physical and logical interfaces [31-3](#)

numbering of [31-3](#)

configuration guidelines [31-9](#)

configuring Layer 2 interfaces [31-10](#)

EtherChannel (continued)

- default configuration [31-9](#)
- described [31-2](#)
- displaying status [31-16](#)
- forwarding methods [31-6, 31-12](#)
- IEEE 802.3ad, described [31-5](#)
- interaction
 - with STP [31-9](#)
 - with VLANs [31-10](#)
- LACP
 - described [31-5](#)
 - displaying status [31-16](#)
 - hot-standby ports [31-14](#)
 - interaction with other features [31-6](#)
 - modes [31-5](#)
 - port priority [31-15](#)
 - system priority [31-15](#)
- load balancing [31-6, 31-12](#)
- PAgP
 - aggregate-port learners [31-13](#)
 - compatibility with Catalyst 1900 [31-13](#)
 - described [31-4](#)
 - displaying status [31-16](#)
 - interaction with other features [31-5](#)
 - learn method and priority configuration [31-13](#)
 - modes [31-4](#)
 - support for [1-3](#)
- port-channel interfaces
 - described [31-3](#)
 - numbering of [31-3](#)
- port groups [10-3](#)
- support for [1-3](#)
- EtherChannel guard
 - described [17-7](#)
 - disabling [17-14](#)
 - enabling [17-14](#)

- Ethernet VLANs
 - adding [12-8](#)
 - defaults and ranges [12-7](#)
 - modifying [12-8](#)
- EUI [29-3](#)
- events, RMON [24-3](#)
- examples
 - conventions for [xxx](#)
 - network configuration [1-12](#)
- expedite queue for QoS [28-68](#)
- Express Setup [1-2](#)
 - See also getting started guide
- extended crashinfo file [32-21](#)
- extended-range VLANs
 - configuration guidelines [12-12](#)
 - configuring [12-11](#)
 - creating [12-12](#)
 - defined [12-1](#)
- extended system ID
 - MSTP [16-17](#)
 - STP [15-4, 15-14](#)
- extended universal identifier
 - See EUI
- Extensible Authentication Protocol over LAN [9-1](#)

F

- fa0 interface [1-5](#)
- features, incompatible [19-11](#)
- fiber-optic, detecting unidirectional links [22-1](#)
- files
 - basic crashinfo
 - description [32-21](#)
 - location [32-21](#)
 - copying [B-5](#)
 - crashinfo, description [32-21](#)
 - deleting [B-5](#)
 - displaying the contents of [B-8](#)

files (continued)

- extended crashinfo
 - description [32-22](#)
 - location [32-22](#)
- tar
 - creating [B-6](#)
 - displaying the contents of [B-7](#)
 - extracting [B-7](#)
 - image file format [B-24](#)

file system

- displaying available file systems [B-2](#)
- displaying file information [B-3](#)
- local file system names [B-1](#)
- network file system names [B-5](#)
- setting the default [B-3](#)

filtering

- show and more command output [2-10](#)

filtering show and more command output [2-10](#)**flash device, number of [B-1](#)****flooded traffic, blocking [19-7](#)****flow-based packet classification [1-9](#)****flowcharts**

- QoS classification [28-6](#)
- QoS egress queueing and scheduling [28-16](#)
- QoS ingress queueing and scheduling [28-14](#)
- QoS policing and marking [28-10](#)

flowcontrol

- configuring [10-14](#)
- described [10-14](#)

forward-delay time

- MSTP [16-23](#)
- STP [15-21](#)

FTP

- accessing MIB files [A-3](#)
- configuration files
 - downloading [B-13](#)
 - overview [B-12](#)
 - preparing the server [B-13](#)
 - uploading [B-14](#)

FTP (continued)

- image files
 - deleting old image [B-32](#)
 - downloading [B-30](#)
 - preparing the server [B-29](#)
 - uploading [B-32](#)

G

- get-bulk-request operation [26-3](#)
- get-next-request operation [26-3, 26-5](#)
- get-request operation [26-3, 26-5](#)
- get-response operation [26-3](#)
- global configuration mode [2-2](#)
- global leave, IGMP [18-12](#)
- guest VLAN and 802.1x [9-11](#)

guide

- audience [xxix](#)
- purpose of [xxix](#)

guide mode [1-2](#)**GUIs**

See device manager and Network Assistant

H**hello time**

- MSTP [16-22](#)
- STP [15-20](#)

help, for the command line [2-3](#)**history**

- changing the buffer size [2-6](#)
- described [2-6](#)
- disabling [2-7](#)
- recalling commands [2-6](#)

history table, level and number of syslog messages [25-10](#)**host names, in clusters [5-12](#)****hosts, limit on dynamic ports [12-29](#)****HP OpenView [1-4](#)**

HSRP

- automatic cluster recovery [5-11](#)
- cluster standby group considerations [5-10](#)
- See also clusters, cluster standby group, and standby command switch

HTTP over SSL

- see HTTPS

HTTPS [8-38](#)

- configuring [8-41](#)
- self-signed certificate [8-38](#)

HTTP secure server [8-38](#)

I

ICMP

- IPv6 [29-4](#)
- time-exceeded messages [32-16](#)
- traceroute and [32-16](#)

ICMP ping

- executing [32-13](#)
- overview [32-13](#)

ICMPv6 [29-4](#)

IDS appliances

- and ingress RSPAN [23-20](#)
- and ingress SPAN [23-13](#)

IEEE 802.1D

- See STP

IEEE 802.1p [14-1](#)

IEEE 802.1Q

- and trunk ports [10-3](#)
- configuration limitations [12-15](#)
- encapsulation [12-14](#)
- native VLAN for untagged traffic [12-19](#)

IEEE 802.1s

- See MSTP

IEEE 802.1w

- See RSTP

IEEE 802.1x

- See port-based authentication

IEEE 802.3ad

- See EtherChannel

IEEE 802.3x flow control [10-14](#)ifIndex values, SNMP [26-6](#)IFS [1-4](#)

IGMP

- configurable leave timer
 - described [18-5](#)
 - enabling [18-11](#)
- flooded multicast traffic
 - controlling the length of time [18-12](#)
 - disabling on an interface [18-13](#)
 - global leave [18-12](#)
 - query solicitation [18-12](#)
 - recovering from flood mode [18-12](#)
- joining multicast group [18-3](#)
- join messages [18-3](#)
- leave processing, enabling [18-10, 30-9](#)
- leaving multicast group [18-5](#)
- queries [18-4](#)
- report suppression
 - described [18-6](#)
 - disabling [18-15, 30-11](#)
- supported versions [18-2](#)
- support for [1-3](#)

IGMP filtering

- configuring [18-24](#)
- default configuration [18-24](#)
- described [18-23](#)
- monitoring [18-28](#)
- support for [1-3](#)

IGMP groups

- configuring filtering [18-27](#)
- setting the maximum number [18-26](#)

IGMP Immediate Leave

- configuration guidelines [18-11](#)
- described [18-5](#)
- enabling [18-10](#)

- IGMP profile
 - applying [18-25](#)
 - configuration mode [18-24](#)
 - configuring [18-25](#)
- IGMP snooping
 - and address aliasing [18-2](#)
 - configuring [18-6](#)
 - default configuration [18-6, 30-5, 30-6](#)
 - definition [18-1](#)
 - enabling and disabling [18-7, 30-6](#)
 - global configuration [18-7](#)
 - Immediate Leave [18-5](#)
 - method [18-8](#)
 - monitoring [18-15, 30-11](#)
 - querier
 - configuration guidelines [18-14](#)
 - configuring [18-14](#)
 - supported versions [18-2](#)
 - support for [1-3](#)
 - VLAN configuration [18-7](#)
- IGMP throttling
 - configuring [18-27](#)
 - default configuration [18-24](#)
 - described [18-24](#)
 - displaying action [18-28](#)
- Immediate Leave, IGMP [18-5](#)
 - enabling [30-9](#)
- inaccessible authentication bypass [9-13](#)
- initial configuration
 - defaults [1-10](#)
 - Express Setup [1-2](#)
 - See also getting started guide and hardware installation guide
- interface
 - number [10-5](#)
 - range macros [10-7](#)
- interface command [10-5](#)
- interface configuration mode [2-3](#)
- interfaces
 - auto-MDIX, configuring [10-15](#)
 - configuration guidelines
 - duplex and speed [10-12](#)
 - configuring
 - procedure [10-5](#)
 - counters, clearing [10-19](#)
 - default configuration [10-9](#)
 - described [10-16](#)
 - descriptive name, adding [10-16](#)
 - displaying information about [10-18](#)
 - flow control [10-14](#)
 - management [1-3](#)
 - monitoring [10-18](#)
 - naming [10-16](#)
 - physical, identifying [10-5](#)
 - range of [10-6](#)
 - restarting [10-19](#)
 - shutting down [10-19](#)
 - speed and duplex, configuring [10-13](#)
 - status [10-18](#)
 - supported [10-4](#)
 - types of [10-1](#)
- interfaces range macro command [10-7](#)
- interface types [10-5](#)
- Internet Protocol version 6
 - See IPv6
- Intrusion Detection System
 - See IDS appliances
- inventory management TLV [21-3, 21-6](#)
- IP ACLs
 - for QoS classification [28-7](#)
- IP addresses
 - 128-bit [29-2](#)
 - candidate or member [5-3, 5-12](#)
 - cluster access [5-2](#)
 - command switch [5-3, 5-10, 5-12](#)
 - discovering [6-26](#)
 - IPv6 [29-2](#)

IP addresses (continued)

- redundant clusters [5-10](#)
- standby command switch [5-10, 5-12](#)

See also IP information

`ip igmp profile` command [18-24](#)

IP information

- assigned
 - manually [3-10](#)
 - through DHCP-based autoconfiguration [3-3](#)
- default configuration [3-3](#)

IP phones

- and QoS [14-1](#)
- automatic classification and queueing [28-19](#)
- configuring [14-4](#)
- ensuring port security with QoS [28-36](#)
- trusted boundary for QoS [28-36](#)

IP precedence [28-2](#)

IP-precedence-to-DSCP map for QoS [28-53](#)

IP Service Level Agreements

See IP SLAs

IP service levels, analyzing [27-1](#)

IP SLAs

- benefits [27-2](#)
- configuration guidelines [27-5](#)
- Control Protocol [27-3](#)
- default configuration [27-5](#)
- definition [27-1](#)
- measuring network performance [27-2](#)
- monitoring [27-7](#)
- operation [27-3](#)
- responder
 - described [27-3](#)
 - enabling [27-6](#)
- response time [27-4](#)
- SNMP support [27-2](#)
- supported metrics [27-2](#)

IP traceroute

- executing [32-16](#)
- overview [32-15](#)

IPv4 and IPv6

- differences [29-2](#)
- dual protocol stacks [29-5](#)

IPv6

- addresses [29-2](#)
- address formats [29-2](#)
- advantages [29-2](#)
- applications [29-5](#)
- autoconfiguration [29-4](#)
- configuring static routes [29-9](#)
- default configuration [29-8](#)
- defined [29-1](#)
- ICMP [29-4](#)
- ICMP rate limiting [29-8](#)
- monitoring [29-11](#)
- neighbor discovery [29-4](#)
- reasons for [29-1](#)
- SDM templates [29-6, 30-1](#)
- supported features [29-3](#)

J

join messages, IGMP [18-3](#)

L**LACP**

See EtherChannel

Layer 2 frames, classification with CoS [28-2](#)

Layer 2 interfaces, default configuration [10-9](#)

Layer 2 traceroute

- and ARP [32-15](#)
- and CDP [32-14](#)
- broadcast traffic [32-14](#)
- described [32-14](#)
- IP addresses and subnets [32-15](#)
- MAC addresses and VLANs [32-15](#)
- multicast traffic [32-15](#)

Layer 2 traceroute (continued)

- multiple devices on a port [32-15](#)
- unicast traffic [32-14](#)
- usage guidelines [32-14](#)

Layer 3 packets, classification methods [28-2](#)

LDAP [4-2](#)

LEDs, switch

See hardware installation guide

lightweight directory access protocol

See LDAP

line configuration mode [2-3](#)

Link Aggregation Control Protocol

See EtherChannel

link failure, detecting unidirectional [16-8](#)

Link Layer Discovery Protocol

See CDP

link local unicast addresses [29-3](#)

links, unidirectional [22-1](#)

link-state tracking

- configuring [31-19](#)
- described [31-17](#)

LLDP

- configuring [21-3](#)
 - characteristics [21-4](#)
 - default configuration [21-3](#)
- disabling and enabling
 - globally [21-5](#)
 - on an interface [21-5](#)
- monitoring and maintaining [21-7](#)
- overview [21-1](#)
- supported TLVs [21-2](#)
- switch stack considerations [21-2](#)
- transmission timer and holdtime, setting [21-4](#)

LLDP-MED

- configuring
 - procedures [21-3](#)
 - TLVs [21-6](#)
- monitoring and maintaining [21-7](#)

LLDP-MED (continued)

- overview [21-1, 21-2](#)
- supported TLVs [21-2](#)

LLDP Media Endpoint Discovery

See LLDP-MED

local SPAN [23-2](#)

location TLV [21-3, 21-6](#)

login authentication

- with RADIUS [8-23](#)
- with TACACS+ [8-14](#)

login banners [6-17](#)

log messages

See system message logging

Long-Reach Ethernet (LRE) technology [1-14](#)

loop guard

- described [17-9](#)
- enabling [17-15](#)
- support for [1-6](#)

LRE profiles, considerations in switch clusters [5-14](#)

M

MAC/PHY configuration status TLV [21-2](#)

MAC addresses

- aging time [6-21](#)
- and VLAN association [6-20](#)
- building the address table [6-20](#)
- default configuration [6-21](#)
- discovering [6-26](#)
- displaying [6-26](#)
- dynamic
 - learning [6-20](#)
 - removing [6-22](#)
- static
 - adding [6-24](#)
 - allowing [6-25](#)
 - characteristics of [6-24](#)
 - dropping [6-25](#)
 - removing [6-24](#)

- MAC address notification, support for [1-10](#)
- MAC address-to-VLAN mapping [12-24](#)
- MAC extended access lists
 - configuring for QoS [28-43](#)
 - for QoS classification [28-5](#)
- macros
 - See Smartports macros
- magic packet [9-15](#)
- manageability features [1-4](#)
- management access
 - in-band
 - browser session [1-5](#)
 - CLI session [1-5](#)
 - device manager [1-5](#)
 - SNMP [1-5](#)
 - out-of-band console port connection [1-5](#)
- management address TLV [21-2](#)
- management options
 - CLI [2-1](#)
 - clustering [1-2](#)
 - CNS [4-1](#)
 - Network Assistant [1-2](#)
 - overview [1-3](#)
- management VLAN
 - considerations in switch clusters [5-7](#)
 - discovery through different management VLANs [5-7](#)
- mapping tables for QoS
 - configuring
 - CoS-to-DSCP [28-52](#)
 - DSCP [28-51](#)
 - DSCP-to-CoS [28-55](#)
 - DSCP-to-DSCP-mutation [28-56](#)
 - IP-precedence-to-DSCP [28-53](#)
 - policed-DSCP [28-54](#)
 - described [28-11](#)
- marking
 - action with aggregate policers [28-49](#)
 - described [28-4, 28-8](#)
- maximum aging time
 - MSTP [16-23](#)
 - STP [15-21](#)
- maximum hop count, MSTP [16-24](#)
- membership mode, VLAN port [12-3](#)
- member switch
 - automatic discovery [5-4](#)
 - defined [5-2](#)
 - managing [5-14](#)
 - passwords [5-12](#)
 - recovering from lost connectivity [32-11](#)
 - requirements [5-3](#)
 - See also candidate switch, cluster standby group, and standby command switch
- messages, to users through banners [6-17](#)
- MIBs
 - accessing files with FTP [A-3](#)
 - location of files [A-3](#)
 - overview [26-1](#)
 - SNMP interaction with [26-4](#)
 - supported [A-1](#)
- mirroring traffic for analysis [23-1](#)
- mismatches, autonegotiation [32-11](#)
- module number [10-5](#)
- monitoring
 - cables for unidirectional links [22-1](#)
 - CDP [20-4](#)
 - features [1-10](#)
 - IGMP
 - filters [18-28](#)
 - snooping [18-15, 30-11](#)
 - interfaces [10-18](#)
 - IP SLAs operations [27-7](#)
 - IPv6 [29-11](#)
 - multicast router interfaces [18-16, 30-12](#)
 - MVR [18-23](#)
 - network traffic for analysis with probe [23-2](#)

monitoring (continued)

- port
 - blocking [19-18](#)
 - protection [19-18](#)
- SFP status [10-18, 32-12](#)
- speed and duplex mode [10-13](#)
- traffic flowing among switches [24-1](#)
- traffic suppression [19-17](#)
- VLANs [12-13](#)
- VMPS [12-28](#)
- VTP [13-16](#)

MSTP

- boundary ports
 - configuration guidelines [16-15](#)
 - described [16-6](#)
- BPDU filtering
 - described [17-3](#)
 - enabling [17-12](#)
- BPDU guard
 - described [17-2](#)
 - enabling [17-11](#)
- CIST, described [16-3](#)
- CIST regional root [16-3](#)
- CIST root [16-5](#)
- configuration guidelines [16-15, 17-10](#)
- configuring
 - forward-delay time [16-23](#)
 - hello time [16-22](#)
 - link type for rapid convergence [16-24](#)
 - maximum aging time [16-23](#)
 - maximum hop count [16-24](#)
 - MST region [16-16](#)
 - neighbor type [16-25](#)
 - path cost [16-20](#)
 - port priority [16-19](#)
 - root switch [16-17](#)
 - secondary root switch [16-18](#)
 - switch priority [16-21](#)

MSTP (continued)

- CST
 - defined [16-3](#)
 - operations between regions [16-4](#)
- default configuration [16-14](#)
- default optional feature configuration [17-9](#)
- displaying status [16-26](#)
- enabling the mode [16-16](#)
- EtherChannel guard
 - described [17-7](#)
 - enabling [17-14](#)
- extended system ID
 - effects on root switch [16-17](#)
 - effects on secondary root switch [16-18](#)
 - unexpected behavior [16-17](#)
- IEEE 802.1s
 - implementation [16-6](#)
 - port role naming change [16-7](#)
 - terminology [16-5](#)
- instances supported [15-9](#)
- interface state, blocking to forwarding [17-2](#)
- interoperability and compatibility among modes [15-10](#)
- interoperability with IEEE 802.1D
 - described [16-8](#)
 - restarting migration process [16-25](#)
- IST
 - defined [16-3](#)
 - master [16-3](#)
 - operations within a region [16-3](#)
- loop guard
 - described [17-9](#)
 - enabling [17-15](#)
- mapping VLANs to MST instance [16-16](#)

MSTP (continued)

- MST region
 - CIST [16-3](#)
 - configuring [16-16](#)
 - described [16-2](#)
 - hop-count mechanism [16-5](#)
 - IST [16-3](#)
 - supported spanning-tree instances [16-2](#)
- optional features supported [1-6](#)
- overview [16-2](#)
- Port Fast
 - described [17-2](#)
 - enabling [17-10](#)
- preventing root switch selection [17-8](#)
- root guard
 - described [17-8](#)
 - enabling [17-15](#)
- root switch
 - configuring [16-17](#)
 - effects of extended system ID [16-17](#)
 - unexpected behavior [16-17](#)
- shutdown Port Fast-enabled port [17-2](#)
- status, displaying [16-26](#)
- multicast groups
 - Immediate Leave [18-5](#)
 - joining [18-3](#)
 - leaving [18-5](#)
 - static joins [18-10, 30-8](#)
- multicast router interfaces, monitoring [18-16, 30-12](#)
- multicast router ports, adding [18-9, 30-8](#)
- multicast storm [19-1](#)
- multicast storm-control command [19-4](#)
- multicast television application [18-18](#)
- multicast VLAN [18-17](#)
- Multicast VLAN Registration
 - See MVR

MVR

- and address aliasing [18-20](#)
- and IGMPv3 [18-20](#)
- configuration guidelines [18-20](#)
- configuring interfaces [18-21](#)
- default configuration [18-19](#)
- described [18-17](#)
- example application [18-18](#)
- modes [18-21](#)
- monitoring [18-23](#)
- multicast television application [18-18](#)
- setting global parameters [18-20](#)
- support for [1-3](#)

N**NAC**

- critical authentication [9-13, 9-33](#)
- IEEE 802.1x authentication using a RADIUS server [9-37](#)
- IEEE 802.1x validation using RADIUS server [9-37](#)
- inaccessible authentication bypass [9-33](#)
- Layer 2 IEEE 802.1x validation [1-8, 9-37](#)
- Layer 2 IEEE802.1x validation [9-17](#)

NameSpace Mapper

See NSM

native VLAN

- configuring [12-19](#)
- default [12-19](#)

neighbor discovery, IPv6 [29-4](#)**Network Admission Control**

See NAC

Network Admission Control Software Configuration Guide [9-39, 9-40](#)**Network Assistant**

- benefits [1-1](#)
- described [1-3](#)
- downloading image files [1-2](#)
- guide mode [1-2](#)

Network Assistant (continued)

- management options [1-2](#)
- requirements [xxx](#)
- upgrading a switch [B-23](#)
- wizards [1-2](#)

network configuration examples

- increasing network performance [1-13](#)
- long-distance, high-bandwidth transport [1-17](#)
- providing network services [1-13](#)
- server aggregation and Linux server cluster [1-15](#)
- small to medium-sized network [1-16](#)

network design

- performance [1-13](#)
- services [1-13](#)

network management

- CDP [20-1](#)
- RMON [24-1](#)
- SNMP [26-1](#)

network performance, measuring with IP SLAs [27-2](#)network policy TLV [21-2, 21-6](#)

Network Time Protocol

See NTP

no commands [2-4](#)

nonhierarchical policy maps

described [28-9](#)

nontrunking mode [12-15](#)normal-range VLANs [12-4](#)

- configuration guidelines [12-5](#)
- configuration modes [12-6](#)
- configuring [12-4](#)
- defined [12-1](#)

note, described [xxx](#)NSM [4-3](#)

NTP

associations

- authenticating [6-4](#)
- defined [6-2](#)
- enabling broadcast messages [6-6](#)
- peer [6-5](#)
- server [6-5](#)

default configuration [6-4](#)displaying the configuration [6-11](#)overview [6-2](#)

restricting access

- creating an access group [6-8](#)
- disabling NTP services per interface [6-10](#)

source IP address, configuring [6-10](#)stratum [6-2](#)support for [1-4](#)synchronizing devices [6-5](#)

time

- services [6-2](#)
- synchronizing [6-2](#)

Ooptimizing system resources [7-1](#)options, management [1-3](#)out-of-profile markdown [1-9](#)

Ppacket modification, with QoS [28-18](#)

PAGP

See EtherChannel

passwords

- default configuration [8-2](#)
- disabling recovery of [8-5](#)
- encrypting [8-3](#)
- for security [1-7](#)
- in clusters [5-13](#)

passwords (continued)

- overview [8-1](#)
- recovery of [32-3](#)
- setting
 - enable [8-3](#)
 - enable secret [8-3](#)
 - Telnet [8-6](#)
 - with usernames [8-6](#)
- VTP domain [13-8](#)

path cost

- MSTP [16-20](#)
- STP [15-18](#)

PC (passive command switch) [5-9](#)

performance, network design [1-13](#)

performance features [1-2](#)

persistent self-signed certificate [8-38](#)

per-VLAN spanning-tree plus

See PVST+

physical ports [10-2](#)

PIM-DVMRP, as snooping method [18-8](#)

ping

- character output description [32-13](#)
- executing [32-13](#)
- overview [32-13](#)

policed-DSCP map for QoS [28-54](#)

policers

- configuring
 - for each matched traffic class [28-46](#)
 - for more than one traffic class [28-49](#)
- described [28-4](#)
- displaying [28-69](#)
- number of [28-32](#)
- types of [28-9](#)

policing

- described [28-4](#)
- token-bucket algorithm [28-9](#)

policy maps for QoS

- characteristics of [28-46](#)
- described [28-7](#)
- displaying [28-70](#)
- nonhierarchical on physical ports
 - described [28-9](#)

Port Aggregation Protocol

See EtherChannel

port-based authentication

- accounting [9-8](#)
- authentication server
 - defined [9-2](#)
 - RADIUS server [9-2](#)
- client, defined [9-2](#)
- configuration guidelines [9-20](#)
- configuring
 - 802.1x authentication [9-22](#)
 - guest VLAN [9-30](#)
 - host mode [9-25](#)
 - inaccessible authentication bypass [9-33](#)
 - manual re-authentication of a client [9-26](#)
 - periodic re-authentication [9-25](#)
 - quiet period [9-26](#)
 - RADIUS server [9-25](#)
 - RADIUS server parameters on the switch [9-24](#)
 - restricted VLAN [9-31](#)
 - switch-to-client frame-retransmission number [9-28](#)
 - switch-to-client retransmission time [9-27](#)
- default configuration [9-19](#)
- described [9-1](#)
- device roles [9-2](#)
- displaying statistics [9-41](#)
- EAPOL-start frame [9-5](#)
- EAP-request/identity frame [9-5](#)
- EAP-response/identity frame [9-5](#)
- encapsulation [9-3](#)

port-based authentication (continued)

- guest VLAN
 - configuration guidelines [9-11, 9-12](#)
 - described [9-11](#)
- host mode [9-7](#)
- inaccessible authentication bypass
 - configuring [9-33](#)
 - described [9-13](#)
 - guidelines [9-21](#)
- initiation and message exchange [9-5](#)
- magic packet [9-15](#)
- method lists [9-22](#)
- multiple-hosts mode, described [9-8](#)
- ports
 - authorization state and dot1x port-control command [9-7](#)
 - authorized and unauthorized [9-7](#)
 - critical [9-13](#)
 - voice VLAN [9-14](#)
- port security
 - and voice VLAN [9-15](#)
 - described [9-14](#)
 - interactions [9-15](#)
 - multiple-hosts mode [9-8](#)
- resetting to default values [9-41](#)
- statistics, displaying [9-41](#)
- switch
 - as proxy [9-3](#)
 - RADIUS client [9-3](#)
- upgrading from a previous release [9-22](#)
- VLAN assignment
 - AAA authorization [9-22](#)
 - characteristics [9-10](#)
 - configuration tasks [9-10](#)
 - described [9-9](#)

port-based authentication (continued)

- voice VLAN
 - described [9-14](#)
 - PVID [9-14](#)
 - VVID [9-14](#)
 - wake-on-LAN, described [9-15](#)
- port blocking [1-3, 19-7](#)
- port-channel
 - See EtherChannel
- port description TLV [21-2](#)
- Port Fast
 - described [17-2](#)
 - enabling [17-10](#)
 - mode, spanning tree [12-25](#)
 - support for [1-6](#)
- port membership modes, VLAN [12-3](#)
- port priority
 - MSTP [16-19](#)
 - STP [15-16](#)
- ports
 - access [10-2](#)
 - blocking [19-7](#)
 - dual-purpose uplink [10-4](#)
 - dynamic access [12-3](#)
 - protected [19-5](#)
 - secure [19-8](#)
 - static-access [12-3, 12-10](#)
 - switch [10-2](#)
 - trunks [12-3, 12-14](#)
 - VLAN assignments [12-10](#)
- port security
 - aging [19-16](#)
 - and QoS trusted boundary [28-36](#)
 - configuring [19-11](#)
 - default configuration [19-10](#)
 - described [19-8](#)
 - displaying [19-18](#)
 - on trunk ports [19-13](#)
 - sticky learning [19-9](#)

port security (continued)

- violations [19-9](#)
- with other features [19-10](#)
- port-shutdown response, VMPS [12-24](#)
- port VLAN ID TLV [21-2](#)
- power management TLV [21-2, 21-6](#)
- preferential treatment of traffic
 - See QoS
- preventing unauthorized access [8-1](#)
- priority
 - overriding CoS [14-6](#)
 - trusting CoS [14-6](#)
- private VLAN edge ports
 - See protected ports
- privileged EXEC mode [2-2](#)
- privilege levels
 - changing the default for lines [8-9](#)
 - command switch [5-15](#)
 - exiting [8-9](#)
 - logging into [8-9](#)
 - mapping on member switches [5-15](#)
 - overview [8-2, 8-7](#)
 - setting a command with [8-8](#)
- protected ports [1-7, 19-5](#)
- pruning, VTP
 - disabling
 - in VTP domain [13-14](#)
 - on a port [12-19](#)
 - enabling
 - in VTP domain [13-14](#)
 - on a port [12-19](#)
 - examples [13-5](#)
 - overview [13-4](#)
- pruning-eligible list
 - changing [12-19](#)
 - for VTP pruning [13-4](#)
 - VLANs [13-14](#)

PVST+

- described [15-9](#)
- IEEE 802.1Q trunking interoperability [15-10](#)
- instances supported [15-9](#)

Q**QoS**

- and MQC commands [28-1](#)
- auto-QoS
 - categorizing traffic [28-20](#)
 - configuration and defaults display [28-29](#)
 - configuration guidelines [28-25](#)
 - described [28-19](#)
 - disabling [28-26](#)
 - displaying generated commands [28-26](#)
 - displaying the initial configuration [28-29](#)
 - effects on running configuration [28-24](#)
 - egress queue defaults [28-20](#)
 - enabling for VoIP [28-25](#)
 - example configuration [28-27](#)
 - ingress queue defaults [28-20](#)
 - list of generated commands [28-21](#)
- basic model [28-4](#)
- classification
 - class maps, described [28-7](#)
 - defined [28-4](#)
 - DSCP transparency, described [28-38](#)
 - flowchart [28-6](#)
 - forwarding treatment [28-3](#)
 - in frames and packets [28-3](#)
 - IP ACLs, described [28-5, 28-7](#)
 - MAC ACLs, described [28-5, 28-7](#)
 - options for IP traffic [28-5](#)
 - options for non-IP traffic [28-5](#)
 - policy maps, described [28-7](#)
 - trust DSCP, described [28-5](#)
 - trusted CoS, described [28-5](#)
 - trust IP precedence, described [28-5](#)

QoS (continued)

- class maps
 - configuring [28-44](#)
 - displaying [28-69](#)
- configuration guidelines
 - auto-QoS [28-25](#)
 - standard QoS [28-32](#)
- configuring
 - aggregate policers [28-49](#)
 - auto-QoS [28-19](#)
 - default port CoS value [28-36](#)
 - DSCP maps [28-51](#)
 - DSCP transparency [28-38](#)
 - DSCP trust states bordering another domain [28-38](#)
 - egress queue characteristics [28-62](#)
 - ingress queue characteristics [28-57](#)
 - IP extended ACLs [28-42](#)
 - IP standard ACLs [28-41](#)
 - MAC ACLs [28-43](#)
 - port trust states within the domain [28-34](#)
 - trusted boundary [28-36](#)
- default auto configuration [28-20](#)
- default standard configuration [28-30](#)
- displaying statistics [28-69](#)
- DSCP transparency [28-38](#)
- egress queues
 - allocating buffer space [28-62](#)
 - buffer allocation scheme, described [28-17](#)
 - configuring shaped weights for SRR [28-66](#)
 - configuring shared weights for SRR [28-67](#)
 - described [28-4](#)
 - displaying the threshold map [28-65](#)
 - flowchart [28-16](#)
 - mapping DSCP or CoS values [28-65](#)
 - scheduling, described [28-4](#)
 - setting WTD thresholds [28-62](#)
 - WTD, described [28-18](#)
- enabling globally [28-33](#)

QoS (continued)

- flowcharts
 - classification [28-6](#)
 - egress queueing and scheduling [28-16](#)
 - ingress queueing and scheduling [28-14](#)
 - policing and marking [28-10](#)
- implicit deny [28-7](#)
- ingress queues
 - allocating bandwidth [28-60](#)
 - allocating buffer space [28-59](#)
 - buffer and bandwidth allocation, described [28-15](#)
 - configuring shared weights for SRR [28-60](#)
 - configuring the priority queue [28-61](#)
 - described [28-4](#)
 - displaying the threshold map [28-59](#)
 - flowchart [28-14](#)
 - mapping DSCP or CoS values [28-58](#)
 - priority queue, described [28-15](#)
 - scheduling, described [28-4](#)
 - setting WTD thresholds [28-58](#)
 - WTD, described [28-15](#)
- IP phones
 - automatic classification and queueing [28-19](#)
 - detection and trusted settings [28-19, 28-36](#)
- limiting bandwidth on egress interface [28-68](#)
- mapping tables
 - CoS-to-DSCP [28-52](#)
 - displaying [28-69](#)
 - DSCP-to-CoS [28-55](#)
 - DSCP-to-DSCP-mutation [28-56](#)
 - IP-precedence-to-DSCP [28-53](#)
 - policed-DSCP [28-54](#)
 - types of [28-11](#)
- marked-down actions [28-48](#)
- marking, described [28-4, 28-8](#)
- overview [28-1](#)
- packet modification [28-18](#)

QoS (continued)

- policers
 - configuring [28-48, 28-50](#)
 - described [28-8](#)
 - displaying [28-69](#)
 - number of [28-32](#)
 - types of [28-9](#)
 - policies, attaching to an interface [28-8](#)
 - policing
 - described [28-4, 28-8](#)
 - token bucket algorithm [28-9](#)
 - policy maps
 - characteristics of [28-46](#)
 - displaying [28-70](#)
 - nonhierarchical on physical ports [28-46](#)
 - QoS label, defined [28-4](#)
 - queues
 - configuring egress characteristics [28-62](#)
 - configuring ingress characteristics [28-57](#)
 - high priority (expedite) [28-18, 28-68](#)
 - location of [28-12](#)
 - SRR, described [28-13](#)
 - WTD, described [28-12](#)
 - rewrites [28-18](#)
 - support for [1-9](#)
 - trust states
 - bordering another domain [28-38](#)
 - described [28-5](#)
 - trusted device [28-36](#)
 - within the domain [28-34](#)
- quality of service
 - See QoS
- queries, IGMP [18-4](#)
- query solicitation, IGMP [18-12](#)

R**RADIUS**

- attributes
 - vendor-proprietary [8-31](#)
 - vendor-specific [8-29](#)
 - configuring
 - accounting [8-28](#)
 - authentication [8-23](#)
 - authorization [8-27](#)
 - communication, global [8-21, 8-29](#)
 - communication, per-server [8-20, 8-21](#)
 - multiple UDP ports [8-20](#)
 - default configuration [8-20](#)
 - defining AAA server groups [8-25](#)
 - displaying the configuration [8-31](#)
 - identifying the server [8-20](#)
 - in clusters [5-14](#)
 - limiting the services to the user [8-27](#)
 - method list, defined [8-19](#)
 - operation of [8-19](#)
 - overview [8-18](#)
 - suggested network environments [8-18](#)
 - support for [1-8](#)
 - tracking services accessed by user [8-28](#)
- range
 - macro [10-7](#)
 - of interfaces [10-6](#)
- rapid convergence [16-10](#)
- rapid per-VLAN spanning-tree plus
 - See rapid PVST+
- rapid PVST+
 - described [15-9](#)
 - IEEE 802.1Q trunking interoperability [15-10](#)
 - instances supported [15-9](#)
- Rapid Spanning Tree Protocol
 - See RSTP
- rcommand command [5-14](#)

- RCP
 - configuration files
 - downloading [B-17](#)
 - overview [B-15](#)
 - preparing the server [B-16](#)
 - uploading [B-18](#)
 - image files
 - deleting old image [B-36](#)
 - downloading [B-35](#)
 - preparing the server [B-33](#)
 - uploading [B-37](#)
- reconfirmation interval, VMPS, changing [12-27](#)
- reconfirming dynamic VLAN membership [12-27](#)
- recovery procedures [32-1](#)
- redundancy
 - EtherChannel [31-3](#)
 - STP
 - backbone [15-8](#)
 - path cost [12-22](#)
 - port priority [12-20](#)
- redundant links and UplinkFast [17-13](#)
- reloading software [3-16](#)
- Remote Authentication Dial-In User Service
 - See RADIUS
- Remote Copy Protocol
 - See RCP
- Remote Network Monitoring
 - See RMON
- Remote SPAN
 - See RSPAN
- remote SPAN [23-2](#)
- report suppression, IGMP
 - described [18-6](#)
 - disabling [18-15, 30-11](#)
- requirements
 - cluster [xxx](#)
 - device manager [xxx](#)
 - Network Assistant [xxx](#)
- resetting a UDLD-shutdown interface [22-6](#)
- responder, IP SLAs
 - described [27-3](#)
 - enabling [27-6](#)
- response time, measuring with IP SLAs [27-4](#)
- restricted VLAN
 - configuring [9-31](#)
 - described [9-12](#)
 - using with IEEE 802.1x [9-12](#)
- restricting access
 - NTP services [6-8](#)
 - overview [8-1](#)
 - passwords and privilege levels [8-2](#)
 - RADIUS [8-17](#)
 - TACACS+ [8-10](#)
- retry count, VMPS, changing [12-28](#)
- RFC
 - 1112, IP multicast and IGMP [18-2](#)
 - 1157, SNMPv1 [26-2](#)
 - 1305, NTP [6-2](#)
 - 1757, RMON [24-2](#)
 - 1901, SNMPv2C [26-2](#)
 - 1902 to 1907, SNMPv2 [26-2](#)
 - 2236, IP multicast and IGMP [18-2](#)
 - 2273-2275, SNMPv3 [26-2](#)
- RMON
 - default configuration [24-3](#)
 - displaying status [24-6](#)
 - enabling alarms and events [24-3](#)
 - groups supported [24-2](#)
 - overview [24-1](#)
 - statistics
 - collecting group Ethernet [24-5](#)
 - collecting group history [24-5](#)
 - support for [1-10](#)
- root guard
 - described [17-8](#)
 - enabling [17-15](#)
 - support for [1-6](#)

root switch

MSTP [16-17](#)STP [15-14](#)

RSPAN

characteristics [23-7](#)configuration guidelines [23-16](#)default configuration [23-9](#)defined [23-2](#)destination ports [23-6](#)displaying status [23-22](#)interaction with other features [23-8](#)monitored ports [23-5](#)monitoring ports [23-6](#)overview [1-10, 23-1](#)received traffic [23-4](#)

sessions

creating [23-16](#)defined [23-3](#)limiting source traffic to specific VLANs [23-21](#)specifying monitored ports [23-16](#)with ingress traffic enabled [23-20](#)source ports [23-5](#)transmitted traffic [23-5](#)VLAN-based [23-6](#)

RSTP

active topology [16-9](#)

BPDU

format [16-12](#)processing [16-13](#)designated port, defined [16-9](#)designated switch, defined [16-9](#)

interoperability with IEEE 802.1D

described [16-8](#)restarting migration process [16-25](#)topology changes [16-13](#)overview [16-8](#)

port roles

described [16-9](#)synchronized [16-11](#)

RSTP (continued)

proposal-agreement handshake process [16-10](#)

rapid convergence

described [16-10](#)edge ports and Port Fast [16-10](#)point-to-point links [16-10, 16-24](#)root ports [16-10](#)root port, defined [16-9](#)

See also MSTP

running configuration

replacing [B-19, B-20](#)rolling back [B-19, B-20](#)running configuration, saving [3-10](#)

S

SC (standby command switch) [5-9](#)scheduled reloads [3-16](#)

SDM

described [7-1](#)

templates

configuring [7-2](#)number of [7-1](#)

SDM template

configuration guidelines [7-2](#)configuring [7-2](#)types of [7-1](#)

secure HTTP client

configuring [8-43](#)displaying [8-43](#)

secure HTTP server

configuring [8-41](#)displaying [8-43](#)

secure MAC addresses

deleting [19-15](#)maximum number of [19-9](#)types of [19-8](#)secure ports, configuring [19-8](#)secure remote connections [8-33](#)

Secure Shell

See SSH

Secure Socket Layer

See SSL

security, port [19-8](#)

security features [1-7](#)

sequence numbers in log messages [25-8](#)

server mode, VTP [13-3](#)

service-provider network, MSTP and RSTP [16-1](#)

set-request operation [26-5](#)

setup program

failed command switch replacement [32-10](#)

replacing failed command switch [32-8](#)

severity levels, defining in system messages [25-8](#)

SFPs

monitoring status of [10-18, 32-12](#)

security and identification [32-12](#)

status, displaying [32-12](#)

shaped round robin

See SRR

show and more command output, filtering [2-10](#)

show cdp traffic command [20-5](#)

show cluster members command [5-14](#)

show configuration command [10-16](#)

show forward command [32-20](#)

show interfaces command [10-13, 10-16](#)

show lldp traffic command [21-8](#)

show platform forward command [32-20](#)

show running-config command

interface description in [10-16](#)

shutdown command on interfaces [10-19](#)

Simple Network Management Protocol

See SNMP

Smartports macros

applying Cisco-default macros [11-6](#)

applying global parameter values [11-5, 11-6](#)

applying macros [11-5](#)

applying parameter values [11-5, 11-7](#)

configuration guidelines [11-2](#)

Smartports macros (continued)

creating [11-4](#)

default configuration [11-2](#)

defined [11-1](#)

displaying [11-8](#)

tracing [11-3](#)

website [11-2](#)

SNAP [20-1](#)

SNMP

accessing MIB variables with [26-4](#)

agent

described [26-4](#)

disabling [26-8](#)

and IP SLAs [27-2](#)

authentication level [26-11](#)

community strings

configuring [26-8](#)

for cluster switches [26-4](#)

overview [26-4](#)

configuration examples [26-17](#)

default configuration [26-7](#)

engine ID [26-7](#)

groups [26-7, 26-10](#)

host [26-7](#)

ifIndex values [26-6](#)

in-band management [1-5](#)

in clusters [5-13](#)

informs

and trap keyword [26-12](#)

described [26-5](#)

differences from traps [26-5](#)

disabling [26-15](#)

enabling [26-15](#)

limiting access by TFTP servers [26-16](#)

limiting system log messages to NMS [25-10](#)

manager functions [1-4, 26-3](#)

managing clusters with [5-15](#)

SNMP (continued)

MIBs

- location of [A-3](#)
- supported [A-1](#)

notifications [26-5](#)

overview [26-1, 26-4](#)

security levels [26-3](#)

status, displaying [26-18](#)

system contact and location [26-15](#)

trap manager, configuring [26-14](#)

traps

- described [26-3, 26-5](#)
- differences from informs [26-5](#)
- disabling [26-15](#)
- enabling [26-12](#)
- enabling MAC address notification [6-22](#)
- overview [26-1, 26-5](#)
- types of [26-12](#)

users [26-7, 26-10](#)

versions supported [26-2](#)

SNMPv1 [26-2](#)

SNMPv2C [26-2](#)

SNMPv3 [26-2](#)

snooping, IGMP [18-1](#)

software images

- location in flash [B-24](#)
 - recovery procedures [32-2](#)
 - scheduling reloads [3-16](#)
 - tar file format, described [B-24](#)
- See also downloading and uploading

source-and-destination-IP address based forwarding, EtherChannel [31-7](#)

source-and-destination MAC address forwarding, EtherChannel [31-6](#)

source-IP address based forwarding, EtherChannel [31-7](#)

source-MAC address forwarding, EtherChannel [31-6](#)

SPAN

configuration guidelines [23-10](#)

default configuration [23-9](#)

destination ports [23-6](#)

displaying status [23-22](#)

interaction with other features [23-8](#)

monitored ports [23-5](#)

monitoring ports [23-6](#)

overview [1-10, 23-1](#)

ports, restrictions [19-11](#)

received traffic [23-4](#)

sessions

- configuring ingress forwarding [23-14, 23-21](#)
- creating [23-10](#)
- defined [23-3](#)
- limiting source traffic to specific VLANs [23-14](#)
- removing destination (monitoring) ports [23-12](#)
- specifying monitored ports [23-10](#)
- with ingress traffic enabled [23-13](#)

source ports [23-5](#)

transmitted traffic [23-5](#)

VLAN-based [23-6](#)

spanning tree and native VLANs [12-15](#)

Spanning Tree Protocol

See STP

SPAN traffic [23-4](#)

SRR

configuring

- shaped weights on egress queues [28-66](#)
- shared weights on egress queues [28-67](#)
- shared weights on ingress queues [28-60](#)

described [28-13](#)

shaped mode [28-13](#)

shared mode [28-13](#)

support for [1-9](#)

SSH

- configuring [8-34](#)
- cryptographic software image [8-33](#)
- described [1-5, 8-33](#)
- encryption methods [8-34](#)
- user authentication methods, supported [8-34](#)

SSL

- configuration guidelines [8-40](#)
- configuring a secure HTTP client [8-43](#)
- configuring a secure HTTP server [8-41](#)
- cryptographic software image [8-37](#)
- described [8-37](#)
- monitoring [8-43](#)

standby command switch

- configuring
- considerations [5-10](#)
- defined [5-2](#)
- priority [5-9](#)
- requirements [5-3](#)
- virtual IP address [5-10](#)

See also cluster standby group and HSRP

standby group, cluster

See cluster standby group and HSRP

startup configuration

- booting
 - manually [3-13](#)
 - specific image [3-14](#)
- clearing [B-19](#)
- configuration file
 - automatically downloading [3-12](#)
 - specifying the filename [3-12](#)
- default boot configuration [3-12](#)

stateless autoconfiguration [29-4](#)

static access ports

- assigning to VLAN [12-10](#)
- defined [10-3, 12-3](#)

static addresses

See addresses

static MAC addressing [1-7](#)

static routes

- configuring for IPv6 [29-9](#)

static VLAN membership [12-2](#)

statistics

- 802.1x [9-41](#)
- CDP [20-4](#)
- interface [10-18](#)
- LLDP [21-7](#)
- LLDP-MED [21-7](#)
- QoS ingress and egress [28-69](#)
- RMON group Ethernet [24-5](#)
- RMON group history [24-5](#)
- SNMP input and output [26-18](#)
- VTP [13-16](#)

sticky learning [19-9](#)

storm control

- configuring [19-3](#)
- described [19-1](#)
- disabling [19-5](#)
- displaying [19-18](#)
- support for [1-3](#)
- thresholds [19-1](#)

STP

- accelerating root port selection [17-4](#)

BackboneFast

- described [17-5](#)
- disabling [17-14](#)
- enabling [17-13](#)

BPDU filtering

- described [17-3](#)
- disabling [17-12](#)
- enabling [17-12](#)

BPDU guard

- described [17-2](#)
- disabling [17-12](#)
- enabling [17-11](#)

BPDU message exchange [15-3](#)

- configuration guidelines [15-12, 17-10](#)

STP (continued)

- configuring
 - forward-delay time [15-21](#)
 - hello time [15-20](#)
 - maximum aging time [15-21](#)
 - path cost [15-18](#)
 - port priority [15-16](#)
 - root switch [15-14](#)
 - secondary root switch [15-16](#)
 - spanning-tree mode [15-13](#)
 - switch priority [15-19](#)
 - transmit hold-count [15-22](#)
- counters, clearing [15-22](#)
- default configuration [15-11](#)
- default optional feature configuration [17-9](#)
- designated port, defined [15-3](#)
- designated switch, defined [15-3](#)
- detecting indirect link failures [17-5](#)
- disabling [15-14](#)
- displaying status [15-22](#)
- EtherChannel guard
 - described [17-7](#)
 - disabling [17-14](#)
 - enabling [17-14](#)
- extended system ID
 - effects on root switch [15-14](#)
 - effects on the secondary root switch [15-16](#)
 - overview [15-4](#)
 - unexpected behavior [15-14](#)
- features supported [1-6](#)
- IEEE 802.1D and bridge ID [15-4](#)
- IEEE 802.1D and multicast addresses [15-8](#)
- IEEE 802.1t and VLAN identifier [15-4](#)
- inferior BPDU [15-3](#)
- instances supported [15-9](#)
- interface state, blocking to forwarding [17-2](#)

STP (continued)

- interface states
 - blocking [15-6](#)
 - disabled [15-7](#)
 - forwarding [15-5, 15-6](#)
 - learning [15-6](#)
 - listening [15-6](#)
 - overview [15-4](#)
- interoperability and compatibility among modes [15-10](#)
- limitations with IEEE 802.1Q trunks [15-10](#)
- load sharing
 - overview [12-20](#)
 - using path costs [12-22](#)
 - using port priorities [12-20](#)
- loop guard
 - described [17-9](#)
 - enabling [17-15](#)
- modes supported [15-9](#)
- multicast addresses, effect of [15-8](#)
- optional features supported [1-6](#)
- overview [15-2](#)
- path costs [12-22](#)
- Port Fast
 - described [17-2](#)
 - enabling [17-10](#)
- port priorities [12-21](#)
- preventing root switch selection [17-8](#)
- protocols supported [15-9](#)
- redundant connectivity [15-8](#)
- root guard
 - described [17-8](#)
 - enabling [17-15](#)
- root port, defined [15-3](#)
- root switch
 - configuring [15-14](#)
 - effects of extended system ID [15-4, 15-14](#)
 - election [15-3](#)
 - unexpected behavior [15-14](#)

STP (continued)

- shutdown Port Fast-enabled port [17-2](#)
- status, displaying [15-22](#)
- superior BPDU [15-3](#)
- timers, described [15-20](#)
- UplinkFast
 - described [17-3](#)
 - enabling [17-13](#)
- stratum, NTP [6-2](#)
- success response, VMPS [12-24](#)
- summer time [6-13](#)
- SunNet Manager [1-4](#)
- switch clustering technology [5-1](#)
 - See also clusters, switch
- switch console port [1-5](#)
- Switch Database Management
 - See SDM
- Switched Port Analyzer
 - See SPAN
- switched ports [10-2](#)
- switchport block multicast command [19-7](#)
- switchport block unicast command [19-7](#)
- switchport protected command [19-6](#)
- switch priority
 - MSTP [16-21](#)
 - STP [15-19](#)
- switch software features [1-1](#)
- syslog
 - See system message logging
- system capabilities TLV [21-2](#)
- system clock
 - configuring
 - daylight saving time [6-13](#)
 - manually [6-11](#)
 - summer time [6-13](#)
 - time zones [6-12](#)
 - displaying the time and date [6-12](#)
 - overview [6-1](#)
 - See also NTP

- system description TLV [21-2](#)
- system message logging
 - default configuration [25-3](#)
 - defining error message severity levels [25-8](#)
 - disabling [25-4](#)
 - displaying the configuration [25-13](#)
 - enabling [25-4](#)
 - facility keywords, described [25-13](#)
 - level keywords, described [25-9](#)
 - limiting messages [25-10](#)
 - message format [25-2](#)
 - overview [25-1](#)
 - sequence numbers, enabling and disabling [25-8](#)
 - setting the display destination device [25-5](#)
 - synchronizing log messages [25-6](#)
 - syslog facility [1-10](#)
 - time stamps, enabling and disabling [25-7](#)
 - UNIX syslog servers
 - configuring the daemon [25-12](#)
 - configuring the logging facility [25-12](#)
 - facilities supported [25-13](#)
- system name
 - default configuration [6-15](#)
 - default setting [6-15](#)
 - manual configuration [6-15](#)
 - See also DNS
- system name TLV [21-2](#)
- system prompt, default setting [6-14, 6-15](#)
- system resources, optimizing [7-1](#)

T

- TACACS+
 - accounting, defined [8-11](#)
 - authentication, defined [8-11](#)
 - authorization, defined [8-11](#)

TACACS+ (continued)

- configuring
 - accounting [8-17](#)
 - authentication key [8-13](#)
 - authorization [8-16](#)
 - login authentication [8-14](#)
- default configuration [8-13](#)
- displaying the configuration [8-17](#)
- identifying the server [8-13](#)
- in clusters [5-14](#)
- limiting the services to the user [8-16](#)
- operation of [8-12](#)
- overview [8-10](#)
- support for [1-8](#)
- tracking services accessed by user [8-17](#)

tar files

- creating [B-6](#)
- displaying the contents of [B-7](#)
- extracting [B-7](#)
- image file format [B-24](#)

TDR [1-10](#)**Telnet**

- accessing management interfaces [2-10](#)
- number of connections [1-5](#)
- setting a password [8-6](#)

templates, SDM [7-1](#)**temporary self-signed certificate [8-38](#)****Terminal Access Controller Access Control System Plus**

See TACACS+

terminal lines, setting a password [8-6](#)**TFTP**

- configuration files
 - downloading [B-11](#)
 - preparing the server [B-10](#)
 - uploading [B-12](#)
- configuration files in base directory [3-6](#)
- configuring for autoconfiguration [3-6](#)

TFTP (continued)

- image files
 - deleting [B-28](#)
 - downloading [B-27](#)
 - preparing the server [B-26](#)
 - uploading [B-28](#)
- limiting access by servers [26-16](#)
- TFTP server [1-4](#)
- threshold, traffic level [19-2](#)
- time
 - See NTP and system clock
- Time Domain Reflector
 - See TDR
- time stamps in log messages [25-7](#)
- time zones [6-12](#)
- TLVs
 - defined [21-2](#)
 - LLDP [21-2](#)
 - LLDP-MED [21-2](#)
- Token Ring VLANs
 - support for [12-5](#)
 - VTP support [13-4](#)
- ToS [1-9](#)
- traceroute, Layer 2
 - and ARP [32-15](#)
 - and CDP [32-14](#)
 - broadcast traffic [32-14](#)
 - described [32-14](#)
 - IP addresses and subnets [32-15](#)
 - MAC addresses and VLANs [32-15](#)
 - multicast traffic [32-15](#)
 - multiple devices on a port [32-15](#)
 - unicast traffic [32-14](#)
 - usage guidelines [32-14](#)
- traceroute command [32-16](#)
 - See also IP traceroute
- traffic
 - blocking flooded [19-7](#)
- traffic policing [1-9](#)

- traffic suppression [19-1](#)
 - transmit hold-count
 - see STP
 - transparent mode, VTP [13-3, 13-12](#)
 - trap-door mechanism [3-2](#)
 - traps
 - configuring MAC address notification [6-22](#)
 - configuring managers [26-12](#)
 - defined [26-3](#)
 - enabling [6-22, 26-12](#)
 - notification types [26-12](#)
 - overview [26-1, 26-5](#)
 - troubleshooting
 - connectivity problems [32-12, 32-14, 32-15](#)
 - detecting unidirectional links [22-1](#)
 - displaying crash information [32-21](#)
 - setting packet forwarding [32-20](#)
 - SFP security and identification [32-12](#)
 - show forward command [32-20](#)
 - with CiscoWorks [26-4](#)
 - with debug commands [32-18](#)
 - with ping [32-13](#)
 - with system message logging [25-1](#)
 - with traceroute [32-15](#)
 - trunk failover
 - See link-state tracking
 - trunking encapsulation [1-7](#)
 - trunk ports
 - configuring [12-17](#)
 - defined [10-3, 12-3](#)
 - trunks
 - allowed-VLAN list [12-18](#)
 - load sharing
 - setting STP path costs [12-22](#)
 - using STP port priorities [12-20, 12-21](#)
 - native VLAN for untagged traffic [12-19](#)
 - parallel [12-22](#)
 - pruning-eligible list [12-19](#)
 - to non-DTP device [12-14](#)
 - trusted boundary for QoS [28-36](#)
 - trusted port states
 - between QoS domains [28-38](#)
 - classification options [28-5](#)
 - ensuring port security for IP phones [28-36](#)
 - support for [1-9](#)
 - within a QoS domain [28-34](#)
 - trustpoints, CA [8-38](#)
 - twisted-pair Ethernet, detecting unidirectional links [22-1](#)
 - type of service
 - See ToS
-
- ## U
- UDLD
 - configuration guidelines [22-4](#)
 - default configuration [22-4](#)
 - disabling
 - globally [22-5](#)
 - on fiber-optic interfaces [22-5](#)
 - per interface [22-5](#)
 - echoing detection mechanism [22-2](#)
 - enabling
 - globally [22-5](#)
 - per interface [22-5](#)
 - link-detection mechanism [22-1](#)
 - neighbor database [22-2](#)
 - overview [22-1](#)
 - resetting an interface [22-6](#)
 - status, displaying [22-6](#)
 - support for [1-6](#)
 - unauthorized ports with IEEE 802.1x [9-7](#)
 - unicast MAC address filtering [1-4](#)
 - and adding static addresses [6-25](#)
 - and broadcast MAC addresses [6-25](#)
 - and CPU packets [6-25](#)
 - and multicast addresses [6-25](#)
 - and router MAC addresses [6-25](#)

unicast MAC address filtering 1-4 (continued)

- configuration guidelines **6-25**

- described **6-25**

- unicast storm **19-1**

- unicast storm control command **19-4**

- unicast traffic, blocking **19-7**

- UniDirectional Link Detection protocol

- See UDLD

- UNIX syslog servers

- daemon configuration **25-12**

- facilities supported **25-13**

- message logging configuration **25-12**

- unrecognized Type-Length-Value (TLV) support **13-4**

- upgrading a Catalyst 2950 switch

- configuration compatibility issues **C-1**

- differences in configuration commands **C-1**

- feature behavior incompatibilities **C-5**

- incompatible command messages **C-1**

- recommendations **C-1**

- upgrading information

- See release notes

- upgrading software images

- See downloading

- UplinkFast

- described **17-3**

- disabling **17-13**

- enabling **17-13**

- support for **1-6**

- uploading

- configuration files

- preparing **B-10, B-13, B-16**

- reasons for **B-9**

- using FTP **B-14**

- using RCP **B-18**

- using TFTP **B-21**

uploading (continued)

- image files

- preparing **B-26, B-29, B-33**

- reasons for **B-23**

- using FTP **B-32**

- using RCP **B-37**

- using TFTP **B-28**

- user EXEC mode **2-2**

- username-based authentication **8-6**

V

- version-dependent transparent mode **13-4**

- virtual IP address

- cluster standby group **5-10**

- command switch **5-10**

- vlan.dat file **12-4**

- VLAN 1, disabling on a trunk port **12-18**

- VLAN 1 minimization **12-18**

- vlan-assignment response, VMPS **12-24**

- VLAN configuration

- at bootup **12-7**

- saving **12-7**

- VLAN configuration mode **2-2, 12-6**

- VLAN database

- and startup configuration file **12-7**

- and VTP **13-1**

- VLAN configuration saved in **12-6**

- VLANs saved in **12-4**

- vlan database command **12-6**

- VLAN filtering and SPAN **23-6**

- vlan global configuration command **12-6**

- VLAN ID, discovering **6-26**

- VLAN management domain **13-2**

- VLAN Management Policy Server

- See VMPS

- VLAN membership

- confirming **12-27**

- modes **12-3**

VLAN Query Protocol

See VQP

VLANs

adding [12-8](#)

adding to VLAN database [12-8](#)

aging dynamic addresses [15-9](#)

allowed on trunk [12-18](#)

and spanning-tree instances [12-2, 12-6, 12-12](#)

configuration guidelines, extended-range VLANs [12-12](#)

configuration guidelines, normal-range VLANs [12-5](#)

configuration options [12-6](#)

configuring [12-1](#)

configuring IDs 1006 to 4094 [12-12](#)

creating in config-vlan mode [12-8](#)

creating in VLAN configuration mode [12-9](#)

default configuration [12-7](#)

deleting [12-9](#)

described [10-2, 12-1](#)

displaying [12-13](#)

extended-range [12-1, 12-11](#)

features [1-7](#)

illustrated [12-2](#)

limiting source traffic with RSPAN [23-21](#)

limiting source traffic with SPAN [23-14](#)

modifying [12-8](#)

multicast [18-17](#)

native, configuring [12-19](#)

normal-range [12-1, 12-4](#)

number supported [1-7](#)

parameters [12-4](#)

port membership modes [12-3](#)

static-access ports [12-10](#)

STP and IEEE 802.1Q trunks [15-10](#)

supported [12-2](#)

Token Ring [12-5](#)

traffic between [12-2](#)

VTP modes [13-3](#)

VLAN Trunking Protocol

See VTP

VLAN trunks [12-14](#)

VMPS

administering [12-28](#)

configuration example [12-29](#)

configuration guidelines [12-25](#)

default configuration [12-25](#)

description [12-23](#)

dynamic port membership

- described [12-24](#)
- reconfirming [12-27](#)
- troubleshooting [12-29](#)

entering server address [12-26](#)

mapping MAC addresses to VLANs [12-24](#)

monitoring [12-28](#)

reconfirmation interval, changing [12-27](#)

reconfirming membership [12-27](#)

retry count, changing [12-28](#)

voice-over-IP [14-1](#)

voice VLAN

Cisco 7960 phone, port connections [14-1](#)

configuration guidelines [14-3](#)

configuring IP phones for data traffic

- override CoS of incoming frame [14-6](#)
- trust CoS priority of incoming frame [14-6](#)

configuring ports for voice traffic in

- 802.1p priority tagged frames [14-5](#)
- 802.1Q frames [14-4](#)

connecting to an IP phone [14-4](#)

default configuration [14-3](#)

described [14-1](#)

displaying [14-6](#)

IP phone data traffic, described [14-2](#)

IP phone voice traffic, described [14-2](#)

VQP [1-7, 12-23](#)

VTP

- adding a client to a domain [13-14](#)
- advertisements [12-16, 13-3](#)
- and extended-range VLANs [13-1](#)
- and normal-range VLANs [13-1](#)
- client mode, configuring [13-11](#)
- configuration
 - global configuration mode [13-7](#)
 - guidelines [13-8](#)
 - privileged EXEC mode [13-7](#)
 - requirements [13-9](#)
 - saving [13-7](#)
 - VLAN configuration mode [13-7](#)
- configuration mode options [13-7](#)
- configuration requirements [13-9](#)
- configuration revision number
 - guideline [13-14](#)
 - resetting [13-15](#)
- configuring
 - client mode [13-11](#)
 - server mode [13-9](#)
 - transparent mode [13-12](#)
- consistency checks [13-4](#)
- default configuration [13-6](#)
- described [13-1](#)
- disabling [13-12](#)
- domain names [13-8](#)
- domains [13-2](#)
- modes
 - client [13-3, 13-11](#)
 - server [13-3, 13-9](#)
 - transitions [13-3](#)
 - transparent [13-3, 13-12](#)
- monitoring [13-16](#)
- passwords [13-8](#)

VTP (continued)

- pruning
 - disabling [13-14](#)
 - enabling [13-14](#)
 - examples [13-5](#)
 - overview [13-4](#)
 - support for [1-7](#)
- pruning-eligible list, changing [12-19](#)
- server mode, configuring [13-9](#)
- statistics [13-16](#)
- support for [1-7](#)
- Token Ring support [13-4](#)
- transparent mode, configuring [13-12](#)
- using [13-1](#)
- version, guidelines [13-8](#)
- Version 1 [13-4](#)
- Version 2
 - configuration guidelines [13-8](#)
 - disabling [13-13](#)
 - enabling [13-13](#)
 - overview [13-4](#)

W

- web authentication
 - configuring [9-38 to 9-40](#)
 - described [1-7, 9-17](#)
 - fallback for IEEE 802.1x [9-39](#)
- weighted tail drop
 - See WTD
- wizards [1-2](#)
- WTD
 - described [28-12](#)
 - setting thresholds
 - egress queue-sets [28-62](#)
 - ingress queues [28-58](#)
 - support for [1-9](#)

X

Xmodem protocol [32-2](#)